



Marine & Shipboard Fluid Handling Solutions



for Military Applications

A History of Excellence and Service

Since 1936, Cla-Val has produced the world's highest quality automatic control valves for a diverse array of applications and market places.

Cla-Val's tradition of innovation for the marine industry began in 1945 when we first started supplying automatic control valves and associated products to the US Navy for their surface combatant vessels. Over the years, our products have evolved to meet the changing needs of our marine product users. Today, Cla-Val is the leading supplier of control valves to the navies worldwide. Our products can be found on nearly every vessel in the US Naval fleet.

Cla-Val Marine Products are shock and vibration qualified, and constructed of materials that withstand the rigors of seawater service. Our products are built to last for a lifetime, providing precise control and exception performance in the harshest of conditions.

Common applications include:

- AFFF Fire Suppression Systems
- Magazine and Curtain Fire Protection Sprinkling Systems
- Aircraft Fueling Systems
- Ballast and Void Filling
- Shipboard services such as Sanitary Flushing and Evaporator Cooling



Global Headquarters:
Costa Mesa, California



European Headquarters:
Lausanne, Switzerland

Manufacturing and Technical Expertise



All Cla-Val products are made from the highest quality materials and backed by the best warranty in the industry. Because we operate our own in-house foundries, Cla-Val is able to manufacture products in more than 50 different varieties of metals and grades, including Stainless Steel.



Engineering Capabilities



One of Cla-Val's most unique characteristics is the strong focus we place on the continuous improvement of our products. This is embodied by our in-house Engineering Department.

Cla-Val Engineers work hand-in-hand with the US Navy and navies throughout the world to develop real-world solutions to help them meet their unique operational challenges.

Regardless of the complexity of the product or application, Cla-Val has the ability to meet the exacting requirements of our customers.



Cla-Val Marine Products are also available in Stainless Steel and other materials to suit the application.

from concept to reality

Valves and Products for AFFF Fire Fighting Systems

Aqueous film forming foam (AFFF) systems are highly effective in marine fire suppression applications. AFFF systems employ a variety of valves with different functions to achieve timely and reliable service when it matters most.

Each of the Cla-Val products used in the AFFF is designed and manufactured to perform with fast-acting precision, playing a critical role in protecting life and equipment in the event of a fire aboard surface vessels.



Optional Products for the SOPV

The Cla-Val Motor Operated Pilot Valve (MOPV) and the Electronic Operated Pilot Valve (EOPV) are ideal for controlling the flow of fluids either in fire main piping or in the AFFF mixture process.

1



CSM5M-3A Solenoid Control Valve

The CSM5M-3A is used in magazine sprinkling systems, hangar deck and water curtain sprinkling applications.

2



100PM-3 Powertrol Valve

The Powertrol Valve is used in the foam liquid supply line from the tank to the proportioner.

3



181M-2 Hy-Check Valve

The Hy-Check acts as a check valve to permit flow in one direction only. When flow stops and back pressure develops, the valve closes, thus stopping return flow.

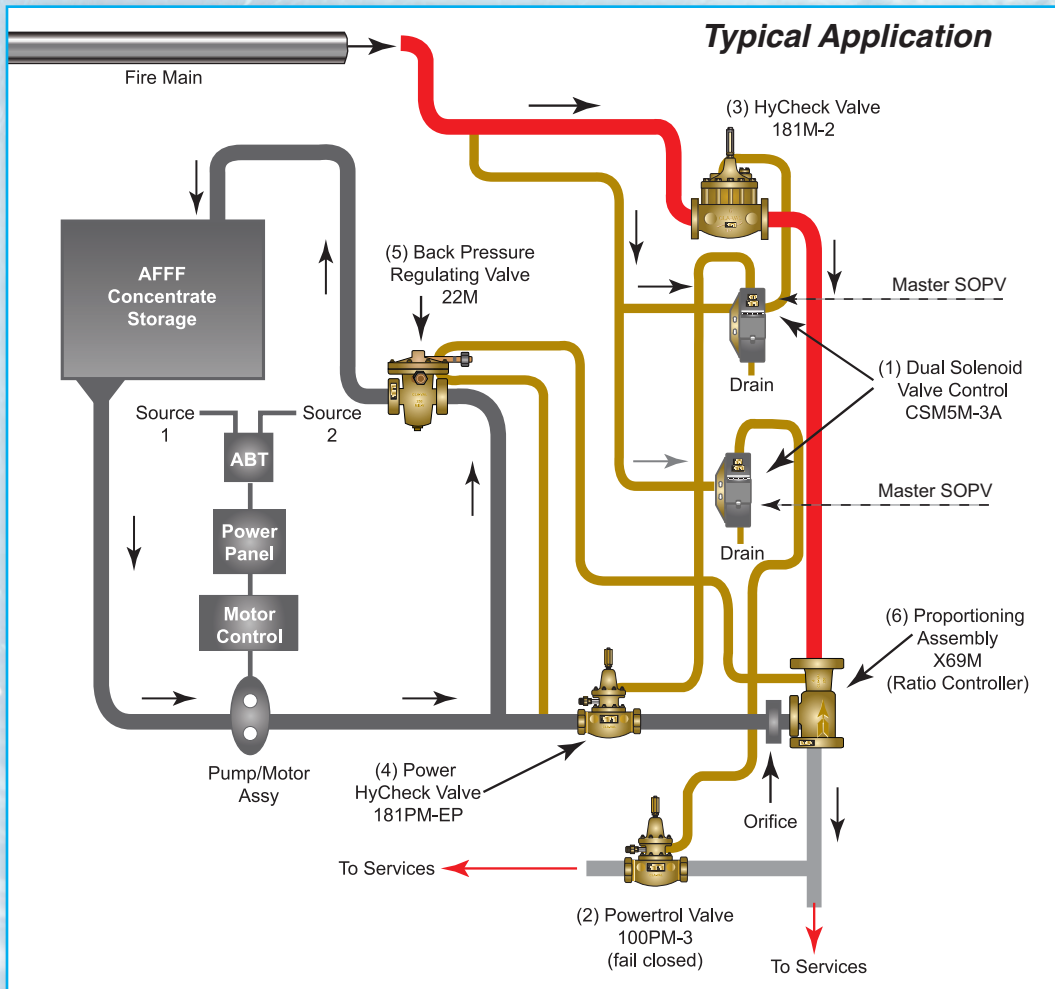

6



X69M Proportioning Assembly

This assembly helps to ensure that water and AFFF concentrates are released in the proper proportion to effectively suppress fires.

5



22M Back Pressure Regulating Valve

The 22M Back Pressure Regulating Valve controls upstream pressure to ensure proper delivery of fluids.

4



81PM Series Hydraulic Check Valve

The 81PM Series prevents return flow throughout the deployment of the AFFF mixture.

Magazine and Hangar Deck Sprinkling Valves

Cla-Val Magazine Sprinkling Valves are designed and manufactured for shipboard fire protection and hangar deck sprinkling systems. These all hydraulic valves provide dependable, accurate and responsive performance while requiring little maintenance.

The valves are built to the exacting standards of navies from around the world and built to last a lifetime. Like all of Cla-Val's marine products, our magazine and curtain sprinkling valves are shock and vibration tested and constructed of the finest materials, including castings in a wide range of materials, including Stainless Steel, produced in our US foundries in Southern California.

The quality of Cla-Val products is best illustrated by the significant number of our valves we have provided to the US Navy since the 1940s, making Cla-Val one of the most trusted names in the marine industry today.



100PM-4B

The Cla-Val 100PM-4B is an Automatic Control Valve for Dry and Wet Type Magazine Sprinkling Systems. Complies with MIL-V 17501 F.



CM15M-BA3-3

Manual Control Valve for local, adjacent and remote control stations. Complies with MIL-F1183.



81M-3

Check valve used in water curtain sprinkling systems. Built to MIL-F20042.



100M-1KR/KHR

Hydraulically-operated control valve, specifically designed for use in wet-type magazine sprinkler systems. Complies with MIL F-1183

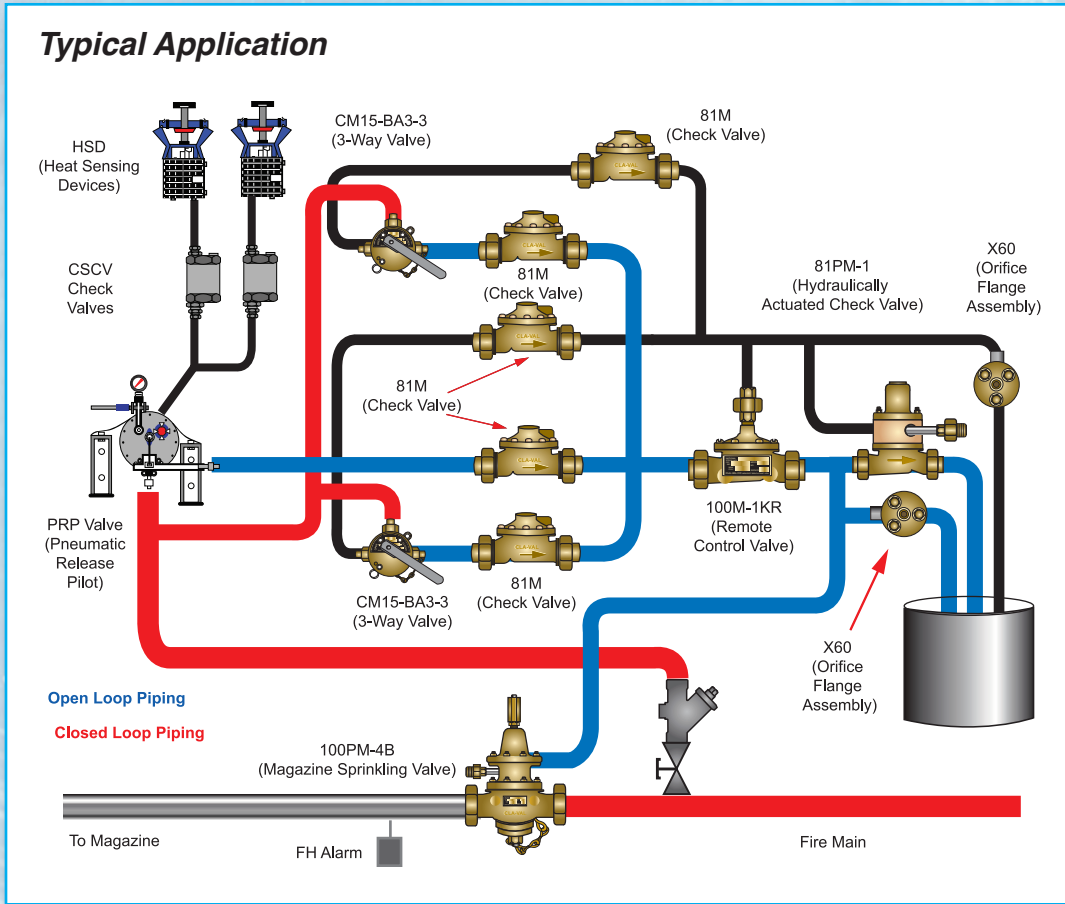

3

4

Other Commonly Used Products for Shipboard Services

100M-2

Normally open automatic sprinkler control valve built to MIL-F20042, Class 250 specifications.

Navy Standard Valve

Automatic control valve built to meet the requirements of MIL-V 17501 F.



X60M

The X60M Orifice Assembly is available in two sizes: .063" or 0.98" to meet the requirements of most shipboard magazine sprinkler systems.

Aircraft Fueling System Valves and Products

Fueling is an integral part of everyday operations on aircraft carriers. The ability to safely and efficiently deliver fuel to waiting aircraft depends on both the skill of the crew members and the reliability of the equipment they use.

Cla-Val's significant experience in the ground fueling industry has enabled us to become a key supplier to the US Navy and naval fleets throughout the world. Our fueling valves, nozzles and accessories are built in the US by an experienced manufacturing team. Quality is assured by an extensive QC Program, that starts in the foundry and continues throughout the manufacturing process. That, coupled with the superior design of each Cla-Val product, ensures peak performance during the aircraft fueling process.



50M

The 50M Pressure Relief Valve is a pilot operated modulating type valve that employs a spring-loaded, adjustable relief control to operate the main valve according to pre-set pressure settings in gasoline or jet fuel distribution systems.



50M-5

The 50M-5 is a remote sensing pressure relief valve specifically designed for use in marine fuel oil transfer system aboard surface marine vessels. Available in globe pattern, sizes 1-1/2" through 8"; and 8" for angle pattern valves. Built to meet the requirements of MIL-F20042, Class 150 and 250 for flanged and MIL-F1183 for union-style valves.



302M

The 302M Automatic Fueling and Defaulting Valve is used in AV gas and jet fuel systems on CUNA, LHARY, LED, LO, LOHN Class vessels. Available in size 2-1/2", this flanged valve is built in accordance with MIL-F20042, Class 250.



50M-2

The 50M-2 Pressure Relief Valve is designed specifically for back pressure sustaining or pressure relief in constant pressure pumping systems. Available in a wide range of sizes and built to MIL Spec, MIL-F-20042, Class 150 or 250, with flanged end connections.



1626M

The 1626M is a float control designed for use in marine filter separators for aviation and diesel fuel distribution systems. Built to meet the requirements of MIL spec MIL-F20042.



403M

The 403M is designed for use in filter separators for fluid and pressure control, in aviation and diesel fuel systems. This flanged valve is available in a wide range of sizes and is built in accordance with MIL Spec MIL-F20042, Class 150 and Class 250.

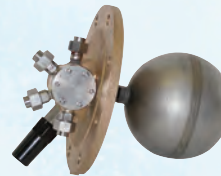

CFF18M-H2

The CFF18M-H2 is one of several flanged float controls designed specifically for use in AV-Gas, JP-5 Jet Fuel and Diesel fuel-water filter separator applications.

Materials of construction include Sil-Brazed Nickel-Copper piping for long service life.



341GF-D3

The 341GF-D3 Military Underwing Fueling Nozzle is used for pressurized refueling of military jets. Its dual-swivel inlet allows for easier and safer connections, even on worn adapters. This nozzle is constructed of durable hard anodized aluminum and stainless steel for a long dependable service life.



CFF18T-H2

The Cla-Val CFF18T-H2 Fuel-Water Separator Control Assembly automatically operates the fuel discharge valve and the water drain valve of fuel-water filter separators.

It is mounted to a flange on the side of the separator vessel in the sump.

Products for Critical Shipboard Services

Cla-Val manufactures a wide range of products that are the ideal solution for a variety applications throughout surface and sub-surface marine vessels,

Cla-Val Automatic Control Valves and associated products play a critical role in the comfort and safety of the ship's crew. From potable water and air conditioning systems to sanitary flushing, seawater isolation, and lube oil systems, Cla-Val products work around the clock to ensure that the operational support systems of the ship are performing at peak efficiency. The quality of materials and workmanship that is integral to every Cla-Val product assures long life, low maintenance and the highest level of reliability.



50M-1 Lube Oil Unloading Valve

Cla-Val Model 50M-1 is a remote sensing pressure relief valve used in the lubricating system for turbine bearings propulsion systems of surface vessels and submarines.

Available in sizes 2-1/2" through 8", either globe or angle patterns, flanged ASTM B16.5.

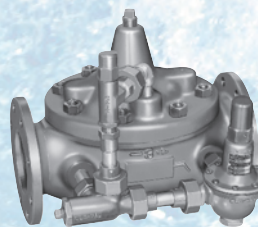

90FM-2 Pressure Reducing Valve

Cla-Val Model 90FM-2 is used in shipboard piping systems, whenever pressure reducing is required. Typical applications include sanitary flushing and evaporator cooling systems. For valves, 4" - 8", use Model 90M.

MIL Specifications:

- Union-type valves: MIL-F1183
- Flanged-type valves: MIL-F20042

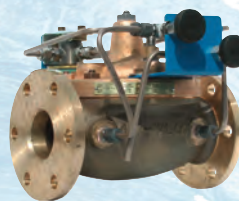

136M-2 Solenoid Control Valve

Cla-Val Model 136M-2 is a solenoid control valve typically used in air conditioning and chilled fresh water systems.

MIL Specifications:

- Union-type valves: MIL-F1183
- Flanged-type valves: MIL-F20042, Class 150 ASA Class 150 (B16.24) available upon request



50-20 Seawater Service Pressure Relief Valve

The Cla-Val Model 50-20 Pressure Relief Valve automatically relieves excess pressure in non-combatant marine pumping systems.

Constructed of Nickel Aluminum Bronze, this durable valve can stand up to the rigors of seawater service while maintaining steady line pressure, preventing surges during pump starting and stopping.

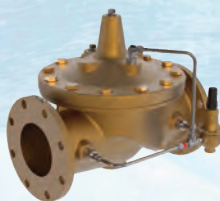

90-42 Seawater Service Pressure Reducing Valve

Cla-Val Model 90-42 is used to automatically reduce higher inlet pressure to a steady, lower outlet pressure in shipboard fire protection piping system.

UL Listed for fire protection applications and available in a variety of materials, the 90-42 is ideal for use in any application where line pressure reduction is desired.



RP-2M2 Series Backflow Preventer

Cla-Val RP-2M Series Backflow Preventers are used anywhere return flow prevention is desired. It is an ideal choice for potable water and seawater isolation systems. Available sizes: 3/4", 1", and 1-1/2". RP-9M available in 2-1/2".

MIL Specifications:

- Union-type valves: MIL-F1183
- Flanged-type valves: MIL-F20042, Class 150

Built to Last a Lifetime

Cla-Val products comply with applicable MIL specifications and meet the requirements of our own rigorous in-house quality program. Our valves and associated products are constructed of the finest quality materials cast in onsite foundries located in Costa Mesa, California. All valves are also available in Stainless Steel.

Cla-Val American-made marine products are manufactured by a team of experienced craftsmen who are committed to producing the best quality valves for shipboard applications in the US and throughout the world.

Ballast and Void Filling Valves

Cla-Val 240M Series Ballast Valves control the balance and buoyancy of surface marine vessels. Depending on sea conditions and individual ship requirements, Cla-Val hydraulically operated ballast valves open or close to fill or drain compartments to attain the desired level of buoyancy and to keep the ship in proper balance. They are also used to help facilitate the launching of small water craft from a larger vessel.

Hull-mounted and submerged, these rugged valves are constructed of top-quality Naval Bronze materials for long life and minimal maintenance. Valves are also available in Stainless Steel.

Whether in the ballast system of an enormous aircraft carrier with thousands of crew members or smaller surface vessels, Cla-Val ballast valves perform with reliability and precision, backed by more than 65 years of experience in the military marine industry.



240M-4

Cla-Val Model 240M-4 is used in the seawater ballast systems of naval aircraft carriers. Constructed of highly durable Naval Bronze, this valve requires little maintenance and will withstand harsh conditions wear-and-tear that continuous exposure to seawater can cause.

Available in 8" and 10" sizes.



240M-3

Cla-Val Model 240M-3 is used in the seawater ballast systems of surface vessels. Constructed of highly durable Naval Bronze, this valve requires little maintenance and will withstand the wear-and-tear that continuous seawater submersion can cause.

Available in 4", 6", 8", 10", 14" and 24" sizes.



Built to last a lifetime

Global Capabilities. Local Expertise.



Cla-Val manufacturing facilities, product training centers, warehouses and sales offices around the world enables us to provide world-class product support to our customers, wherever they are, whenever they need it.

In addition to our extensive manufacturing and foundry facilities in the US, Cla-Val Canada also supports North American customers in a diverse array of industries with superior quality products and services and is one of the continent's leading high volume OEM suppliers.

Cla-Val Europe, located in Lausanne, Switzerland, provides outstanding product and technical support to customers throughout Europe and the Middle East. The products they produce are known for both their innovative design and their exceptional quality and reliability.

Cla-Val UK Ltd. serves the United Kingdom and South Africa with an unparalleled level of customer service and technical expertise. Primary markets include waterworks, fire protection, aviation fueling and industrial processing facilities. Cla-Val products can be found in nearly every waterworks distribution system throughout the UK.

Cla-Val France is one of the leading suppliers of automatic control valves in France. Serving diverse markets ranging from aviation fuel truck manufacturing to water utility companies, Cla-Val France brings a unique combination of industry experience, technical expertise and product know-how to customers in the French marketplace.

Cla-Val Pacific acts as the local presence in Australasia, providing exceptional technical expertise, superior customer support and a fully stocked warehouse in their new facility located in Christchurch, New Zealand.



Global Headquarters

CLA-VAL USA

1701 Placentia Avenue
Costa Mesa, CA 92627
Phone: (949) 722-4800
800-942-6326

www.cla-val.com

E-mail: info@cla-val.com

Worldwide Locations:

CLA-VAL CANADA

4687 Christie Drive
Beamsville, Ontario, Canada L0R 1B4
Phone: (905) 563-4963
E-mail: sales@cla-val.ca

CLA-VAL LATIN AMERICA

AV Patria 2085, Mezzanine
Col. Puerta de Hierro
45116, Zapopan, Jalisco
Phone: + 52 (33) 80007565
E-mail: info@cla-val-latinamerica.com
www.cla-val-latinamerica.com

CLA-VAL EUROPE

Chemin des Mesanges 1
CH-1032 Romanel/Lausanne
Switzerland
Phone: 41-21-643-15-55
E-mail: cla-val@cla-val.ch

CLA-VAL UK

Dainton House
Goods Station Road
GB - Tunbridge Wells
Kent TN1 2 DH England
Phone: 44-1892-514-400
E-mail: info@cla-val.co.uk

CLA-VAL FRANCE

Porte du Grand Lyon 1
ZI de Champ du Périer
France - 01700 Neyon
Phone: 33-4-72-25-92-93
E-mail: cla-val@cla-val.fr

CLA-VAL PACIFIC

45 Kennaway Road
Woolston, Christchurch, 8023
New Zealand
Phone: (64) 39644860
E-mail: info@cla-valpacific.com
www.cla-valpacific.com