

High Performance Axial Fans Model AX

- High Efficiencies • Low Sound

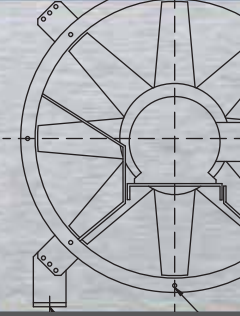

High Performance Axial Fans

Greenheck's high performance axial fan, Model AX, are direct driven axials designed for inline air ventilation in commercial or industrial buildings. The casing design and construction are well suited to indoor or outdoor applications and can be easily installed in ducted or non-ducted systems. The AX is designed to reduce operating costs with improved efficiency. Additionally, the AX blade design offers inherently lower sound levels than other axial fans.



Typical Ventilation Applications include:

- Supply and return fans for air handling equipment
- Continuous duty operation at 110°F
- Emergency smoke and heat exhaust
- Stairwell pressurization
- Parking garage and storage facility exhaust
- Industrial process ventilation
- Tunnel ventilation

The AX is available in 14 sizes that cover a wide range of volumetric flow and pressure conditions. Additionally, the blade pitch is field adjustable to accommodate system changes.

Capacity Ranges:

Volumes up to 125,000 cfm (212,400 m³/hr) and external static pressures to 5 in. wg (1,250 Pa)

Model Number Code

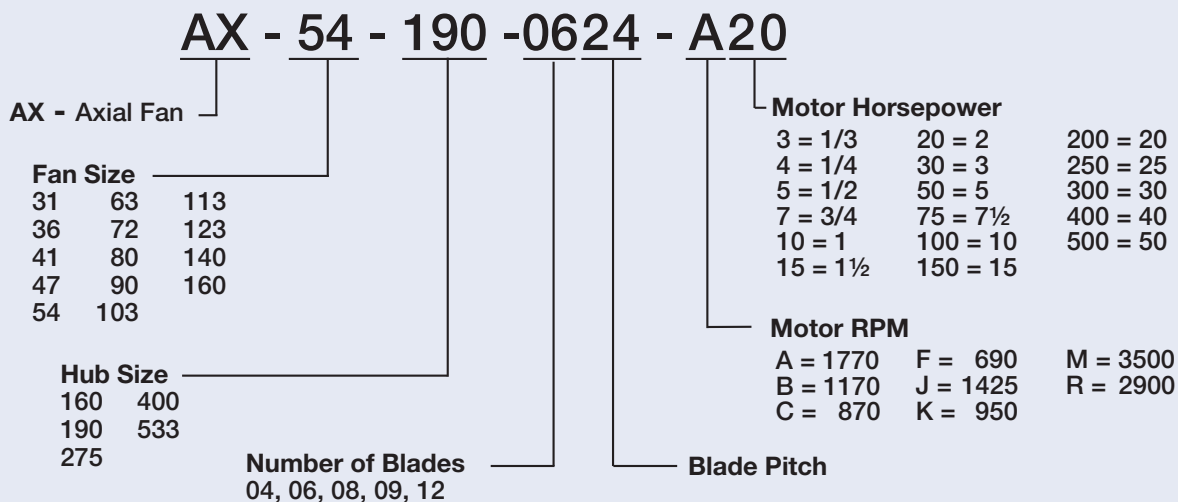

Leading Edge Support

All Greenheck products are supported by the industry's best product literature, electronic media, Computer Aided Product Selection program (CAPS®) and eCAPS® Engineer Application Suite, an online fan selection tool designed specifically for HVAC engineers. You'll also find extensive product and Installation, Operation and Maintenance Manuals (IOM) information on our website.



And, of course, you can always count on the personal service and expertise of our national and international representative organization. To locate your nearest Greenheck representative call 715-359-6171 or visit our web site at greenheck.com



High Performance Propeller

The AX blade shape and hub are designed to move high volumes of air with less power to save on long-term energy costs.

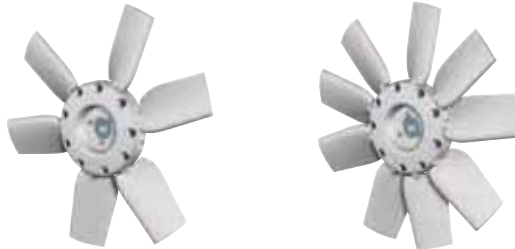

Blades

Tight tolerances between the blades and casing improve overall efficiency. This improved efficiency in turn reduces the overall sound levels, but the AX is even quieter as a result of the wide blade shape and unique blade spacing. The asymmetrical blade locations reduce the blade pass frequency tones while generating a smoother sound spectrum. The airfoil blades are cast aluminum and the pitch is fully adjustable in the field to provide for system balancing.

Hubs

The choice of five different hub diameters, along with variations in blade quantities, ensures that the most economical air performance can be achieved. In addition, during the design process, close attention was paid to the “hub to tip” ratios. This is a comparison of the hub diameter to the “tip to tip” dimension of the blades. Different choices of hub to tip ratios further optimize fan performance and provide a cost effective solution by not oversizing a hub to produce required volumes and pressures. The hubs are constructed from cast aluminum and use a taper lock bushing to secure the hub to the motor shaft.

Available Hub Size in Millimeters
(Number of Blades)

Size	160 (4 or 6)	190 (4 or 6)	275 (6 or 9)	400 (6 or 9)	533 (8 or 12)
31	X				
36	X				
41	X	X			
47	X	X			
54	X	X	X		
63	X	X	X		
72		X	X		
80		X	X	X	
90			X	X	
103			X	X	
113			X	X	X
123				X	X
140				X	X
160				X	X

Extensive R&D and Performance Testing Program

Greenheck engineers used Computational Fluid Dynamics (CFD) and Finite Element Analysis (FEA) programs to design the AX series fans. The AX aerodynamic design and structural endurance were further tested in our state-of-the-art R&D facilities and performance labs.

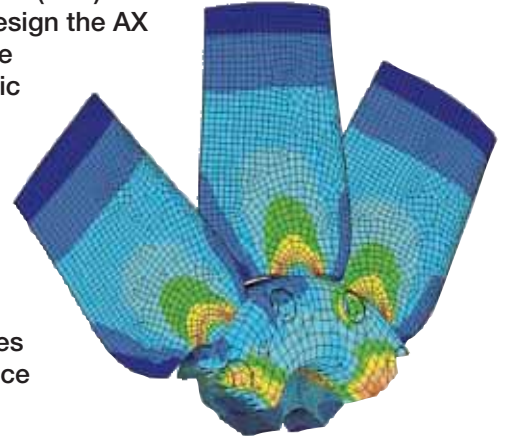

AMCA Licensed

The AX was tested in accordance to AMCA 210 (meets BS 848-1) and is licensed to bear the AMCA Air Performance Seal.

Sound Performance

All published AX sound data was tested in accordance to AMCA 300 (meets BS 848-2).



AMCA licensed Air Performance can be found in Greenheck's Supplement: High Performance Axial Fans, Model AX Performance Supplement Supplement AX Rev. 1 July 2004 R

The AX is available in a variety of casing configurations to provide solutions for many different applications and design requirements.

AX Long Casing (Standard)

The long cased axial is designed for ducted or plenum type applications. The all welded long-casing completely covers the motor and propeller assembly. This design offers numerous mounting options including horizontal or vertical orientations for either ceiling hung or base mounting.



AX Vane Section (Option)

The long cased axial with vane section further improves the efficiency of the standard AX model. The bolt-on section includes aerodynamically shaped vanes that convert the kinetic energy of swirling air into useful static pressure. This design will improve the overall fan efficiency. This is an excellent option for higher pressure ducted applications.



AX Roof Upblast (Option)

The roof upblast axial is designed for roof mounted ventilation. Standard construction includes a heavy gauge spun curb cap to reduce inlet losses, a butterfly damper section for backflow prevention, and a windband section to protect the butterfly dampers from debris. A complete line of roof curbs is available for mounting to a roof deck.



Emergency Smoke Evacuation

The AX model was tested and rated for design time and temperatures used in emergency heat and smoke exhaust applications. Consult your Greenheck representative for time and temperature combinations other than those listed.



Model AX is available with UL/cUL Listing for Power Ventilators for Smoke Control Systems, File no. MH17511

	Operating Temperature		Time Duration	Comments
	°C	°F	Hours	
HT-UL I	150	302	5.0	Per British Spec 7346
HT-UL II	250	482	2.0	
HT-UL III	300	572	.5	
HT-UL IV	300	572	1.0	
HT-UL V	260	500	4.0	Per Industrial Risk Insurers (North America)

Electrostatic Powder Paint and Protective Coatings

All internal and external steel components are electrostatically powder painted prior to assembly with an industrial polyester urethane, Permator™. This finish is excellent for both indoor and outdoor applications and has added resistance to many common chemicals. One advantage of powder coatings is that they offer a uniform, durable and high quality finish that uses a one-coat process applied over a phosphatized surface. Charged paint particles are able to penetrate and fill voids in hard to reach locations like joints or mating pieces, areas often not covered by sprayed on wet paint. For increased chemical resistance or special applications, Greenheck offers a number of other powder coatings. See Greenheck's Product Application Guide, Performance Coatings for Ventilation Products for a complete list of available coatings and their chemical resistance.

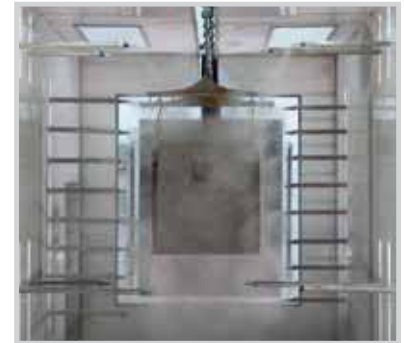

Adjustable Propeller

Cast aluminum airfoil propellers are designed to allow for manual field adjustment of the blade pitch, without removing the propeller from inside the casing or from the motor shaft. The adjustment of the preset blade pitch angle provides a means for system balancing during installation or for accommodating future requirements.

Propeller Balancing and Fan Testing

All propellers are statically and dynamically balanced to assure vibration free operation. In addition, all completely assembled fans are test run at the factory with motor amp measurements taken to ensure proper operation.

Casing

Special care is taken to provide fan casings that are uniform in diameter. Maintaining the roundness of the casing ensures uniform blade tip clearance and maximizes performance. In addition, casings are continuously welded to prevent air leakage. Inlet and outlet flanges are provided with mounting holes for easy, airtight ductwork connections. As a standard, all parts except the propeller are constructed from coated steel. Optional aluminum construction available upon request.

Motors

Motors are available as either IEC (IP55) or NEMA (TEAO, TEFC, or ODP) designs. IEC design motors are variable frequency drive (VFD) compatible, have class F insulation and are capable of wye-delta starting when over 5.5 kW. NEMA motors use across the line starting with options for VFD compatibility. Motors (IEC or NEMA) using 50 Hz power have a 1.0 service factor, while 60 Hz power have 1.15 service factor. Design and construction options for motors include increased thermal insulation, overload protection and extended motor leads. The AX is available with the UL/cUL 705 (Underwriters Laboratory) listing on a wide variety of 50 and 60 Hz motors. This listing ensures the use of UL approved electrical components.



Motor Supports

Rigidly formed and welded to the casing, motor mounting brackets support the weight of the motor and propeller. The supports are securely welded to the fan casing to increase rigidity and prevent vibration. Greenheck's unique three brace design increases the free area in the casing and acts to help straighten airflow.

Installation Flexibility and Fan Vibration Isolation

The compact design of the AX helps when fitting into tight spaces and provides flexibility during design. In addition, integral connection flanges and optional **Universal Mounting** brackets provide additional flexibility to accommodate mounting location changes for last minute modifications. Universal Mounting brackets also provide a connection point for any isolation.

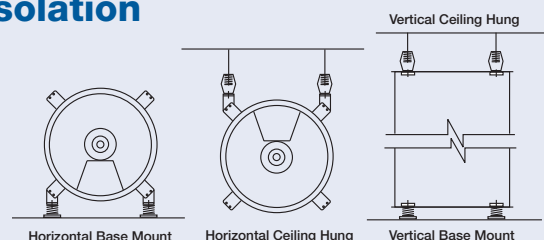

The AX is available with optional accessories to improve the ease of installation and provide safety during operation. Accessories supplied by Greenheck conform to our high standards of quality.

Universal Mounting Brackets allow for field rotation of the AX from horizontal ceiling or base mount and vertical ceiling or base mount applications. The brackets also provide an attachment point for any vibration isolation devices.

Companion Inlet and Outlet Flanges are available to aid the connection of the fan casing flange to ductwork. Companion flanges are prepunched to match the bolt hole dimensions.

Inlet Bells minimize entry losses into the fan from free (non-ducted) inlet conditions to ensure rated performance. Inlet bell guards are supplied to prevent accidental contact with the fan propeller.

Inlet and Outlet Guards protect personnel and equipment in ducted or non-ducted installations. Guards are removable for routine fan maintenance.

Safety Disconnect Switches are available for positive electrical shut-off at the fan. Switches can be factory wired or shipped loose for mounting at the jobsite.

Choices include:

- NEMA-1 / IP23 - General purpose (indoor)
- NEMA-3R / IP32 - Rainproof (outdoor)
- NEMA-4 / IP66 - Watertight (outdoor)



Isolators, both base mount and hanging style, are available in either neoprene or spring mounts. The isolators are furnished in sets of four and are sized to match the total weight of each fan, motor and accessory combination.

Electrical wiring options are available to bring the electrical connections from the motor to the exterior of the fan casing. **Extended Motor Leads** are an extension of the actual motor wires, from within the motor housing, to an externally mounted junction box on the fan casing, **Extended Wiring** can be provided to route electrical leads, from the standard motor junction box, to the exterior of the fan casing. In both cases the leads are enclosed in a protective conduit.



Unit Dimensions

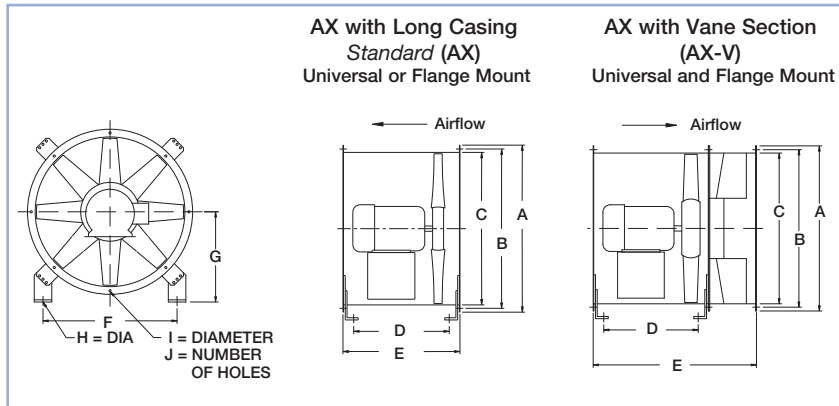

Inches

Size	AX					AX-V		F	G	H	I	J
	A	B	C	D	E	E						
31	15.00	14.00	12.25	12.38	17.00	29.00	13.25	11.13	0.563	0.438	8	
36	17.00	16.00	14.25	12.38	17.00	29.00	14.63	11.88	0.563	0.438	8	
41	19.00	18.00	16.25	15.38	20.00	32.00	16.13	12.50	0.563	0.438	8	
47	21.50	19.75	18.38	18.38	23.00	35.00	17.63	13.25	0.563	0.438	8	
54	24.50	23.25	21.38	23.88	28.50	40.50	19.75	14.38	0.563	0.438	8	
63	27.63	25.75	24.38	27.13	31.75	43.75	22.00	16.13	0.563	0.438	8	
72	31.63	30.25	28.38	29.38	34.00	46.00	24.75	17.50	0.563	0.438	8	
80	35.63	34.25	32.38	27.25	34.50	46.50	27.68	21.00	0.563	0.563	8	
90	39.75	38.00	36.38	29.25	36.50	48.50	30.63	22.50	0.563	0.563	8	
103	43.75	42.25	40.38	28.75	36.50	48.50	36.13	26.50	0.563	0.563	8	
113	48.75	46.50	44.50	45.50	49.13	61.13	40.00	28.50	0.813	0.563	8	
123	52.88	50.75	48.50	45.50	49.13	61.13	44.00	29.50	0.813	0.563	16	
140	59.38	57.25	55.00	45.50	49.13	61.13	51.00	32.00	0.813	0.563	16	
160	67.38	65.25	63.00	45.50	49.13	61.13	59.00	40.00	0.813	0.563	16	

Millimeters

Size	AX					AX-V		F	G	H	I	J
	A	B	C	D	E	E						
31	381	356	311	314	432	737	337	283	14	11	8	
36	432	406	362	314	432	737	372	302	14	11	8	
41	483	457	413	391	508	813	410	318	14	11	8	
47	546	502	467	467	584	889	448	337	14	11	8	
54	622	591	543	607	724	1029	502	365	14	11	8	
63	702	654	619	689	806	1111	559	410	14	11	8	
72	803	768	721	746	864	1168	629	445	14	11	8	
80	905	870	822	692	876	1181	703	533	14	14	8	
90	1010	965	924	743	927	1232	778	572	14	14	8	
103	1111	1073	1026	730	927	1232	918	673	14	14	8	
113	1238	1181	1130	1156	1248	1553	1016	724	14	14	8	
123	1343	1289	1230	1156	1248	1553	1118	749	21	14	16	
140	1508	1454	1400	1156	1248	1553	1295	813	21	14	16	
160	1711	1657	1600	1156	1248	1553	1499	1016	21	14	16	

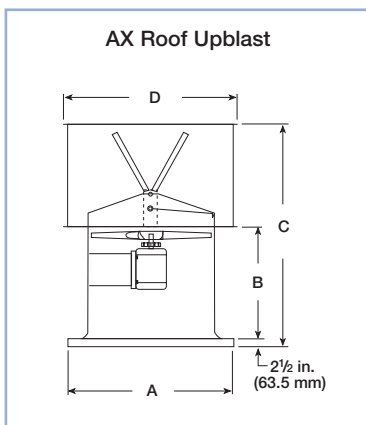

Inches

Size	A	B	C	D
31	20.00	16.75	43.00	19.75
36	22.00	16.75	43.25	19.75
41	24.00	19.75	49.25	19.75
47	26.00	24.75	47.50	25.00
54	31.00	32.00	55.75	27.25
63	34.00	32.75	59.25	31.13
72	38.00	37.50	64.00	31.13
80	42.00	38.00	67.25	37.50
90	46.00	38.50	70.25	44.50
103	50.00	40.00	71.75	44.50
113	54.00	51.75	88.25	49.75
123	58.00	50.50	87.75	56.00
140	64.00	51.50	94.25	62.63
160	73.00	53.00	98.50	68.75

Millimeters

Size	A	B	C	D
31	508	425	1092	502
36	559	425	1099	502
41	610	502	1251	502
47	660	629	1207	635
54	787	813	1416	692
63	864	832	1505	791
72	965	953	1626	791
80	1067	965	1708	953
90	1168	978	1784	1130
103	1270	1016	1822	1130
113	1372	1314	2242	1264
123	1473	1283	2229	1422
140	1651	1308	2394	1591
160	1854	1346	2502	1746

AX Specifications

Inline fans shall be direct driven in AMCA arrangement 4 propeller secured to the motor shaft. The fan housing to be designed with integral punched inlet and outlet flanges to prevent air leakage. The housing shall be constructed of rolled steel with a continuous seam weld. Motor support framework to be constructed of structural steel that is suitable to handle the weights of the motor and propeller. Motor supports within the fan housing to be welded to fan casing.

A tapered lock bushing shall be used to mount the propeller to the motor shaft. Fan propeller shall use cast aluminum airfoil blades. Blades to be adjustable within a cast aluminum hub to allow for performance changes. The propeller shall be both statically and dynamically balanced.

Steel casings and structural components to be coated with a minimum of 3 mils of Permatector™, an electrostatically applied and baked polyester urethane. Finish color shall be RAL 7023, concrete grey. Coating must exceed 1,000 hour salt spray under ASTM B117 test method.

Fan performance shall be based on tests conducted in accordance to AMCA 210 (meets BS 848-1), licensed to bear the AMCA Air Performance Seal in accordance with AMCA Publication 211 and comply with the requirements of the AMCA Certified Ratings Program. All published AX sound data shall be tested in accordance to AMCA 300.

Fan shall be model AX as manufactured by Greenheck Fan Corporation of Schofield, Wisconsin, USA.

Optional Roof Upblast Specification

The fan casing shall include a spun curb cap that is fully welded to the casing and an integral venturi inlet. The curb cap shall be pre-punched with mounting holes. Matching windband and butterfly damper assembly shall be bolted to the casing outlet flange and include integral lifting points.

Optional Vane Section Specification

The bolt-on straightening vane section is to be fastened to outlet flange. Vanes shall be welded to inner diameter of bolt-on section. A minimum of seven blades constructed of at least 10 gauge material to be provided.



Building Value in Air

Greenheck delivers value to mechanical engineers by helping them solve virtually any air quality challenges their clients face with a comprehensive selection of

top quality, innovative air-related equipment. We offer extra value to contractors by providing easy-to-install, competitively priced, reliable products that arrive on time.

And building owners and occupants value the energy efficiency, low maintenance and quiet dependable operation they experience long after the construction project ends.

Our Commitment

As a result of our commitment to continuous improvement, Greenheck reserves the right to change specifications without notice.

Specific Greenheck product warranties are located on greenheck.com within the product area tabs and in the Library under Warranties.



Prepared to Support
Green Building Efforts

