

HOKE® Block Valves

Flanged Double Block & Bleed
Process to Instrument Isolation Valves

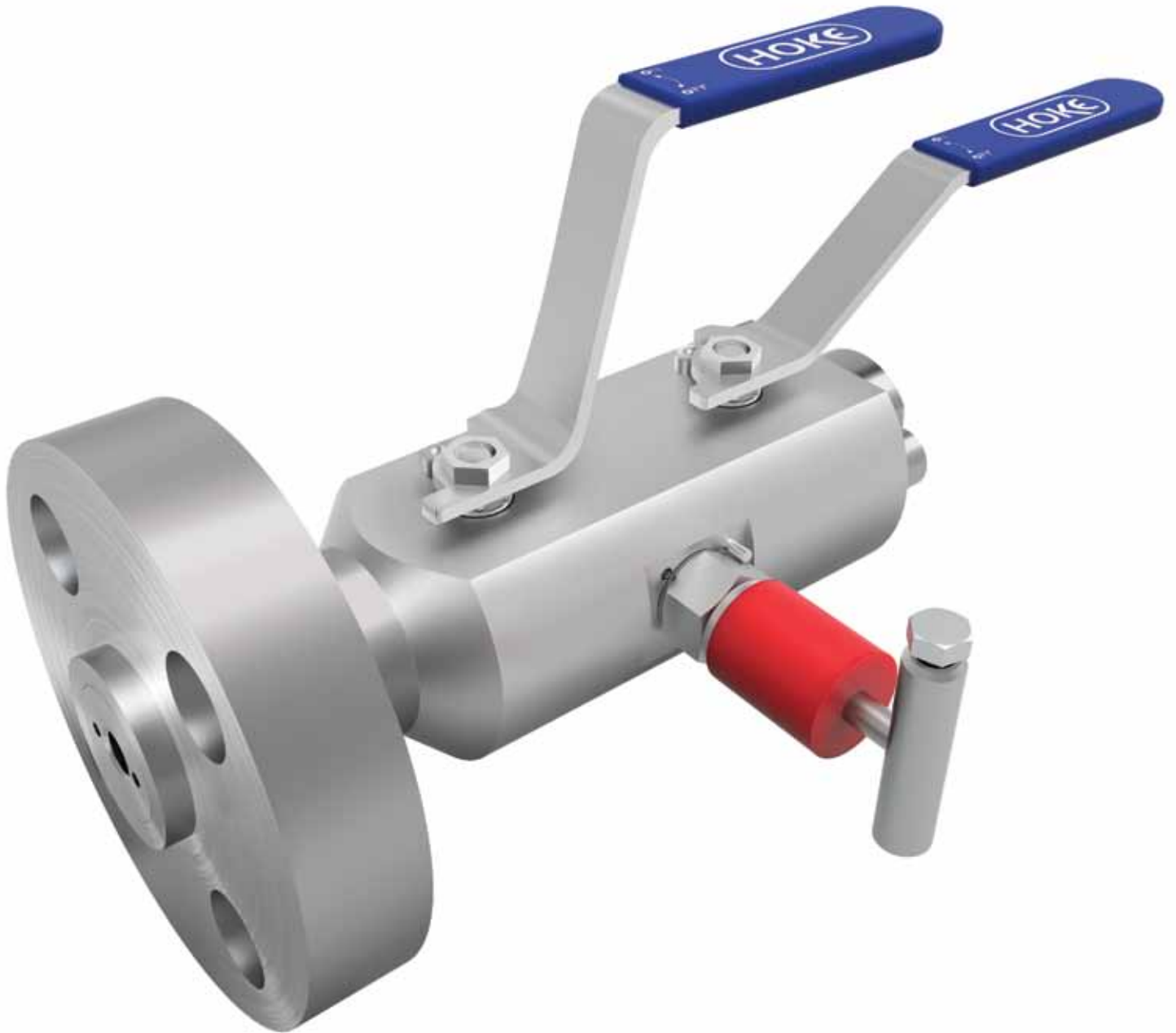

Table of Contents

Conventional vs. HOKE® Block Assemblies 3

Applications, Specifications, Features & Benefits 4

Features | Cutaway 5-6

HOKE® Integral / GYROLOK® Tube Fitting Connections 7

Single Flange Dimensions 8-10

Double Flange Dimensions 11-12

Sample Quills & Injection Probes 13

Materials of Construction 14

API 6A Flanged HOKE® Blocks - Ball and Needle 15

How to Order 16

HOKE® Block - Double Block & Bleed Valves

The HOKE® double block and bleed design of pressure instrument take-off points along with sampling, injection, and drain applications simplifies these designs by making them more compact, rigid, lighter, safer, and lower cost than the conventional piping valve assemblies.

APPLICATIONS

- Pressure instrument take off points
- Sampling Systems (valve has an integral pipe probe or sampling probe)
- Chemical Injection Systems (valve has pipe probe/quill along with integral check valve)
- Hydraulic power units
- Drains for tanks and pipes where space is limited
- Instrument drains and level bridles.

FEATURES & BENEFITS

- Overall length reduced by $\pm 70\%$
- Overall weight reduced by $\pm 80\%$
- Reduced labor cost
- Reduced leak points
- Brings pressure point closer to the instrument

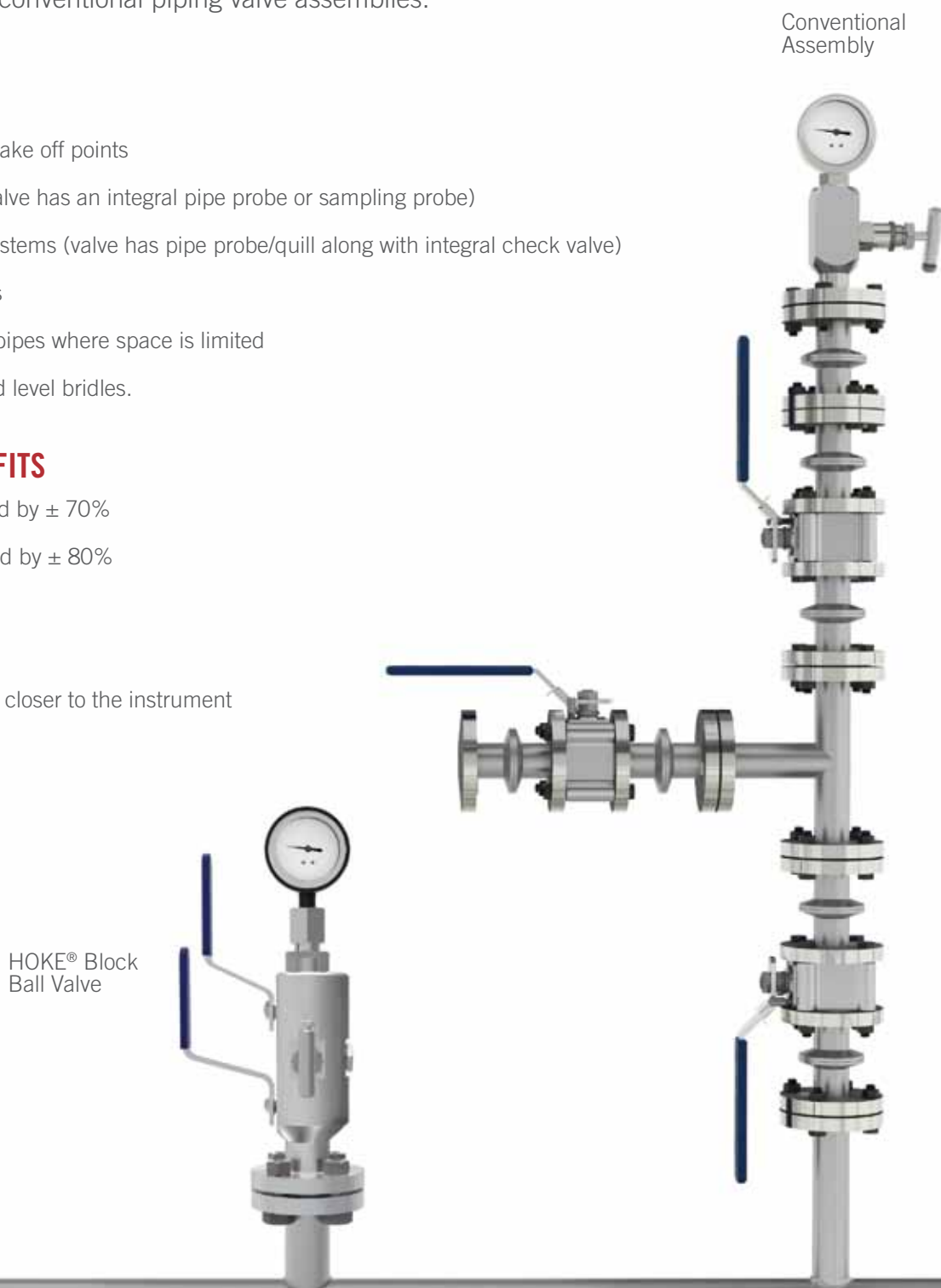

Applications - HOKE® Block Ball Valves

HOKE® Blocks are used as a primary process/piping isolation valve to provide double block and bleed. Valves are typically used on hydrocarbon applications to minimize the size and weight of the pipe-valve assemblies associated with gauge pressure or analytical instrumentation.

Specifications

Working Pressure

- In accordance to ASME B16.5 for class 150 to 2500 along with API 6A/ISO 10423 up to 10k

Working temperatures

- 450°F (232°C) for PEEK seats, PTFE and Graphite packing (fire safe)

Sizes

- 1/2" through 3"
- 10, 15, 20, & 25 mm orifice sizes

Certification

- API 607 5th Edition (Fire Test)
- ASME VIII (pressure boundaries)
- PED
- ANSI B16.5 (flange dimensions)
- EN 10204.3.1 (material traceability)
- NORSOK (Consult factory)

Materials

- Bar or Forged body construction



HOKE® Block advantages and benefits

- 10mm as standard for instrument applications, 15mm, 20mm, and 25mm orifice/bore also available
- Integral back seat on stem prevents stem blow out.
- Needle valve bonnet uses non-rotating stem design on vent valve to increase long life. HOKE® uses Non-Rotating Stem Tip (NRT) technology. When the stem tip contacts the seat, it stops rotating, preventing the cross scoring and eventual leaks that can occur with ball type stems.
- Adjustable , live loaded PTFE or GRAFOIL® packing on needle valves significantly reduces external leakage.
- 4 rings PTFE Chevron style packing, or multi-ring set of Grafoil surrounded by braided graphite standard on vent valve. Verified to exceed US EPA 40 CFR 60 emission standards by more than 5 times.
- Single and double flanged versions available along with NPT and Integral GYROLOK® connections.
- API 607 6th Edition (fire test) Standard (Graphite packed models only)

HOKE® Block Ball Valves

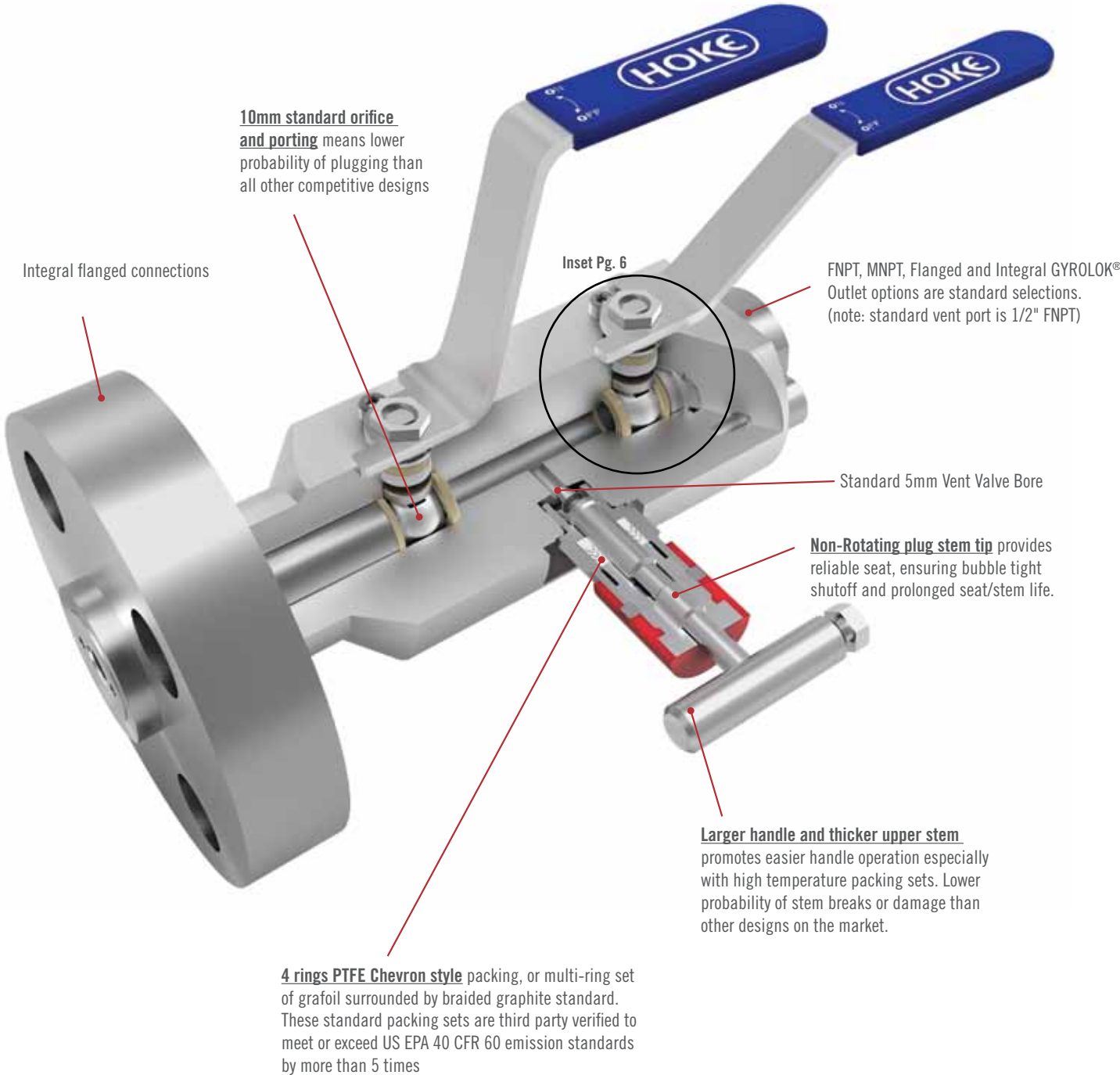

HOKE® Block - Block & Bleed Valves

HOKE® Block - Ball Valves

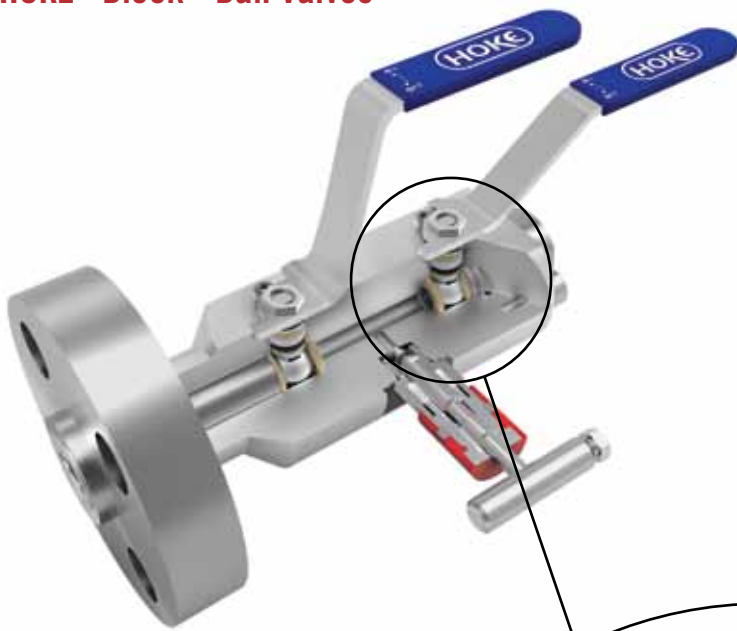

Triple stem seal (packing, o-ring, thrust washer) for improved dynamic sealing

Blowout-proof stem

Adjustable, live loaded PTFE-rings or Grafoil packing

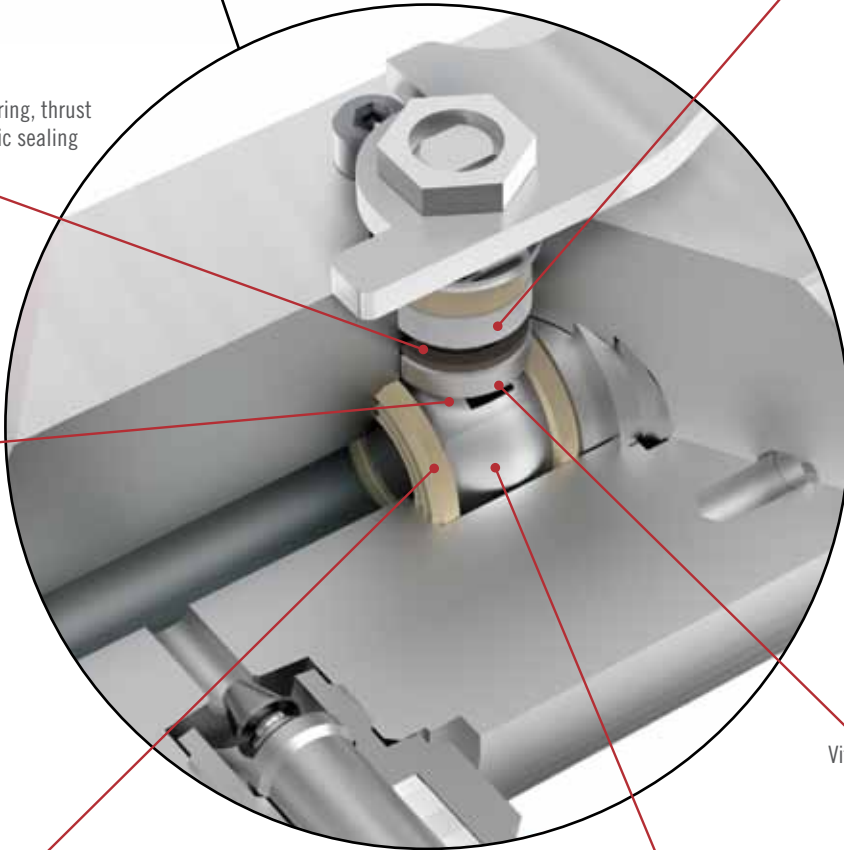

Viton® O-Ring Standard

Standard PEEK seats with serrations and optimal seat contact curvature reduce operating torque, minimize seat wear, and prevent cold flow on the 10mm and 15mm HOKE® Blocks. The larger 20mm and 25mm HOKE® Blocks utilize a flex-seat design and optimal contact curvature to reduce operating torque, minimize seat wear, and prevent cold flow

Bi-directional flow capability

HOKE® Integral / GYROLOK® Tube Fitting Connections

The HOKE® range of standard hand valves, gauge valves and manifolds are available with the option of the integral / GYROLOK® tube fitting connections. The integral / GYROLOK® tube fitting connection is machined directly into the body of the valve, allowing tubing to be directly connected without the use of traditional threaded (NPT, BSP) connections. The integral / GYROLOK® connection provides a safer connection system for high pressure, severe, steam or sour gas service where leakage has dangerous consequences.

An Explanation of Integral GYROLOK® Tube Fitting Connections

- Eliminates traditional threaded tubing connections
- Provides a safer and more consistent tube connection
- Saves assembly time during field assembly
- Reduces potential leak paths
- No need for sealing tape or liquid sealing compounds
- Fully field maintainable
- Successfully used for over 20 years in many offshore applications
- Available in 1/2" and 10mm tube connections

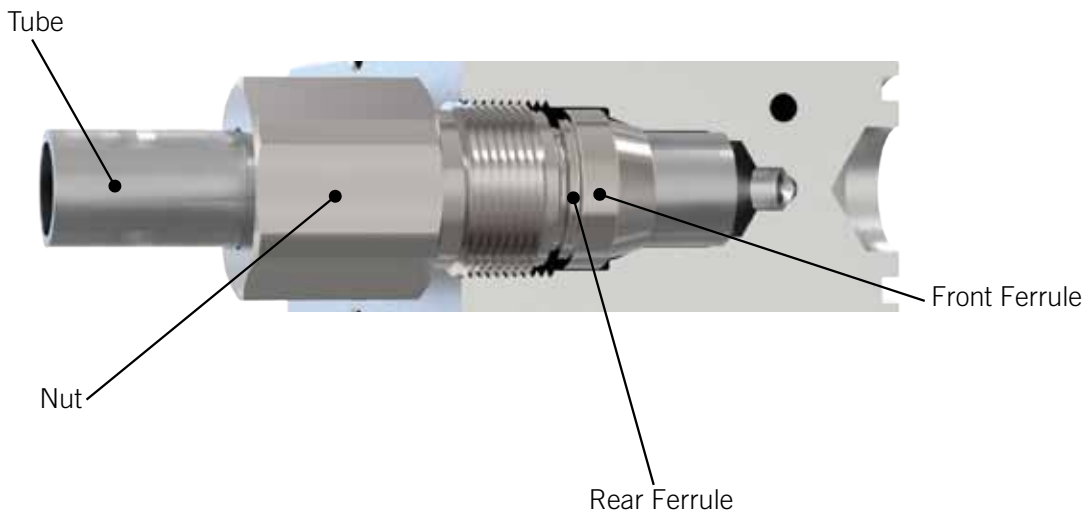

HBA1 10mm Ball Valve - Single Flange

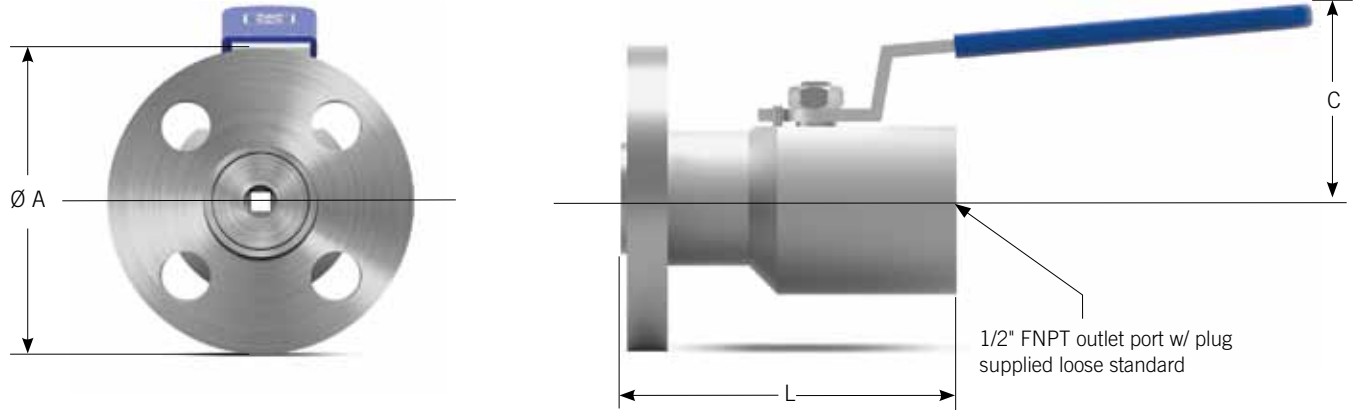

Flange Size	B16.34 Pressure Class	RF Single Flange (10mm)				RTJ Single Flange (10mm)			
		A	C	L	Weight	A	C	L	Weight
1/2"	150	3.50	2.5	4.1	7	N/A	N/A	N/A	N/A
1/2"	300	3.75	2.5	4.1	7	3.75	2.5	4.1	7
1/2"	600	3.75	2.5	4.3	8	3.75	2.5	4.3	8
1/2"	900/1500	4.75	2.5	4.7	12	4.75	2.5	4.7	12
1/2"	2500	5.25	2.5	5.1	16	5.25	2.5	5.1	16
3/4"	150	3.88	2.5	4.1	9	N/A	N/A	N/A	N/A
3/4"	300	4.62	2.5	4.1	9	4.62	2.5	4.1	9
3/4"	600	4.62	2.5	4.5	11	4.62	2.5	4.5	11
3/4"	900/1500	5.12	2.5	4.9	15	5.12	2.5	4.9	15
3/4"	2500	5.50	2.5	5.1	19	5.50	2.5	5.1	19
1"	150	4.25	2.5	4.1	9	4.25	2.5	4.1	9
1"	300	4.88	2.5	4.1	12	4.88	2.5	4.1	12
1"	600	4.88	2.5	4.5	15	4.88	2.5	4.5	15
1"	900/1500	5.88	2.5	4.9	19	5.88	2.5	4.9	19
1"	2500	6.25	2.5	5.1	25	6.25	2.5	5.1	25
1-1/2"	150	5.00	2.5	4.3	14	5.00	2.5	4.3	14
1-1/2"	300	6.12	2.5	4.3	19	6.12	2.5	4.3	19
1-1/2"	600	6.12	2.5	4.7	22	6.12	2.5	4.7	22
1-1/2"	900/1500	7.00	2.5	5.1	30	7.00	2.5	5.1	30
1-1/2"	2500	8.00	2.5	5.9	50	8.00	2.5	5.9	50
2"	150	6.00	2.5	4.3	21	6.00	2.5	4.3	21
2"	300	6.50	2.5	4.5	25	6.50	2.5	4.5	25
2"	600	6.50	2.5	4.9	29	6.50	2.5	4.9	29
2"	900/1500	8.50	2.5	5.3	51	8.50	2.5	5.3	51
2"	2500	9.25	2.5	5.9	69	9.25	2.5	5.9	69

HBA2 10mm Ball Valve and Needle Bleed - Single Flange

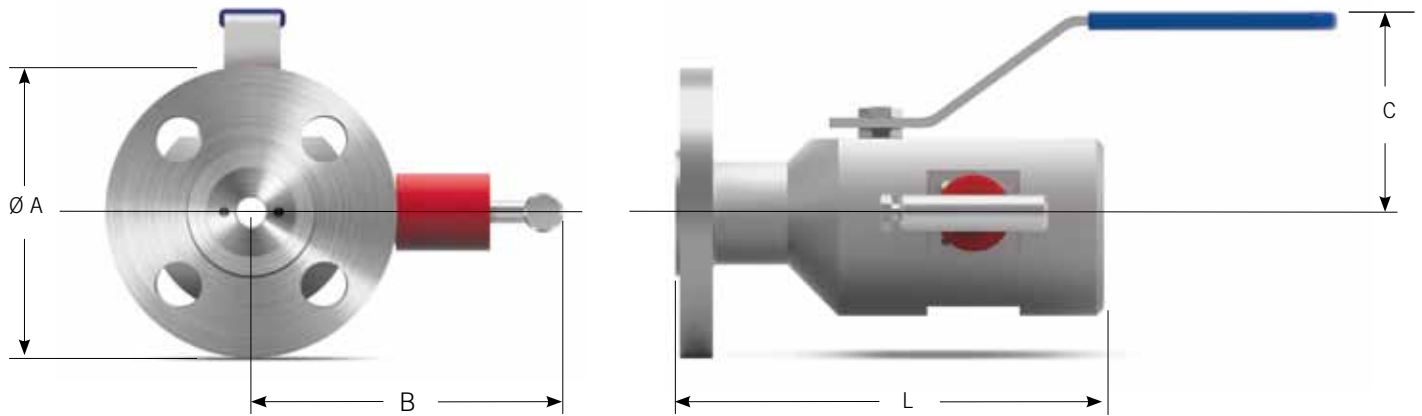

Flange Size	B16.34 Pressure Class	RF Single Flange (10mm)					RTJ Single Flange (10mm)				
		A	B*	C	L	Weight	A	B	C	L	Weight
1/2"	150	3.50	4.0	2.8	7.0	11	N/A	N/A	N/A	N/A	N/A
1/2"	300	3.75	4.0	2.8	7.1	11	3.75	4.0	2.8	7.2	11
1/2"	600	3.75	4.0	2.8	7.3	11	3.75	4.0	2.8	7.3	12
1/2"	900/1500	4.75	4.0	2.8	7.7	14	4.75	4.0	2.8	7.7	14
1/2"	2500	5.25	4.0	2.8	8.0	16	5.25	4.0	2.8	8.0	17
3/4"	150	3.88	4.0	2.8	7.0	11	N/A	N/A	N/A	N/A	N/A
3/4"	300	4.62	4.0	2.8	7.1	13	4.62	4.0	2.8	7.3	13
3/4"	600	4.62	4.0	2.8	7.4	13	4.62	4.0	2.8	7.4	13
3/4"	900/1500	5.12	4.0	2.8	7.8	15	5.12	4.0	2.8	7.8	16
3/4"	2500	5.50	4.0	2.8	8.0	18	5.50	4.0	2.8	8.0	18
1"	150	4.25	4.0	2.8	7.1	12	4.25	4.0	2.8	7.3	12
1"	300	4.88	4.0	2.8	7.2	12	4.88	4.0	2.8	7.4	13
1"	600	4.88	4.0	2.8	7.5	13	4.88	4.0	2.8	7.5	14
1"	900/1500	5.88	4.0	2.8	7.9	18	5.88	4.0	2.8	7.9	18
1"	2500	6.25	4.0	2.8	8.2	21	6.25	4.0	2.8	8.2	22
1-1/2"	150	5.00	4.0	2.8	7.2	13	5.00	4.0	2.8	7.4	14
1-1/2"	300	6.12	4.0	2.8	7.3	16	6.12	4.0	2.8	7.5	17
1-1/2"	600	6.12	4.0	2.8	7.7	17	6.12	4.0	2.8	7.7	18
1-1/2"	900/1500	7.00	4.0	2.8	8.0	23	7.00	4.0	2.8	8.0	24
1-1/2"	2500	8.00	4.0	2.8	8.5	33	8.00	4.0	2.8	8.6	35
2"	150	6.00	4.0	2.8	7.3	15	6.00	4.0	2.8	7.5	16
2"	300	6.50	4.0	2.8	7.4	17	6.50	4.0	2.8	7.6	18
2"	600	6.50	4.0	2.8	7.8	19	6.50	4.0	2.8	7.8	20
2"	900/1500	8.50	4.0	2.8	8.3	33	8.50	4.0	2.8	8.3	34
2"	2500	9.25	4.0	2.8	8.8	45	9.25	4.0	2.8	8.8	47

*When fully open.

HBA3 10mm Double Ball Valve & Needle Bleed - Single Flange

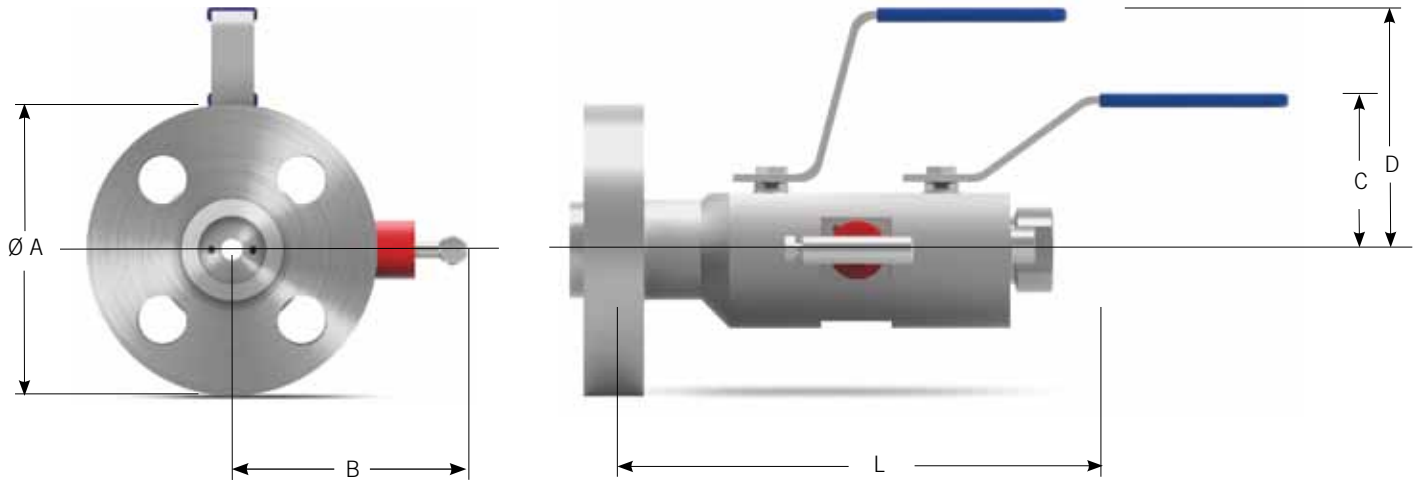

ANSI/ Flange Size	B16.34 Pressure Class	RF Single Flange (10mm)						RTJ Single Flange (10mm)					
		A	B*	C	D	L	Weight	A	B	C	D	L	Weight
1/2"	150	3.50	4.0	2.8	4.3	7.0	11	N/A	N/A	N/A	N/A	N/A	N/A
1/2"	300	3.75	4.0	2.8	4.3	7.1	12	3.75	4.0	2.8	4.3	7.2	12
1/2"	600	3.75	4.0	2.8	4.3	7.3	12	3.75	4.0	2.8	4.3	7.3	12
1/2"	900/1500	4.75	4.0	2.8	4.3	7.7	14	4.75	4.0	2.8	4.3	7.7	15
1/2"	2500	5.25	4.0	2.8	4.3	8.0	17	5.25	4.0	2.8	4.3	8.0	18
3/4"	150	3.88	4.0	2.8	4.3	7.0	12	N/A	N/A	N/A	N/A	N/A	N/A
3/4"	300	4.62	4.0	2.8	4.3	7.1	13	4.62	4.0	2.8	4.3	7.3	13
3/4"	600	4.62	4.0	2.8	4.3	7.4	13	4.62	4.0	2.8	4.3	7.4	13
3/4"	900/1500	5.12	4.0	2.8	4.3	7.8	16	5.12	4.0	2.8	4.3	7.8	16
3/4"	2500	5.50	4.0	2.8	4.3	8.0	18	5.50	4.0	2.8	4.3	8.0	19
1"	150	4.25	4.0	2.8	4.3	7.1	12	4.25	4.0	2.8	4.3	7.3	113
1"	300	4.88	4.0	2.8	4.3	7.2	13	4.88	4.0	2.8	4.3	7.4	14
1"	600	4.88	4.0	2.8	4.3	7.5	14	4.88	4.0	2.8	4.3	7.5	14
1"	900/1500	5.88	4.0	2.8	4.3	7.9	18	5.88	4.0	2.8	4.3	7.9	19
1"	2500	6.25	4.0	2.8	4.3	8.2	22	6.25	4.0	2.8	4.3	8.2	22
1-1/2"	150	5.00	4.0	2.8	4.3	7.2	14	5.00	4.0	2.8	4.3	7.4	14
1-1/2"	300	6.12	4.0	2.8	4.3	7.3	16	6.12	4.0	2.8	4.3	7.5	17
1-1/2"	600	6.12	4.0	2.8	4.3	7.7	18	6.12	4.0	2.8	4.3	7.7	18
1-1/2"	900/1500	7.00	4.0	2.8	4.3	8.0	23	7.00	4.0	2.8	4.3	8.0	24
1-1/2"	2500	8.00	4.0	2.8	4.3	8.5	34	8.00	4.0	2.8	4.3	8.6	36
2"	150	6.00	4.0	2.8	4.3	7.3	16	6.00	4.0	2.8	4.3	7.5	17
2"	300	6.50	4.0	2.8	4.3	7.4	18	6.50	4.0	2.8	4.3	7.6	19
2"	600	6.50	4.0	2.8	4.3	7.8	20	6.50	4.0	2.8	4.3	7.8	21
2"	900/1500	8.50	4.0	2.8	4.3	8.3	33	8.50	4.0	2.8	4.3	8.3	35
2"	2500	9.25	4.0	2.8	4.3	8.8	46	9.25	4.0	2.8	4.3	8.8	48

*When fully open.

HBA1 10mm Ball Valve - Double Flange

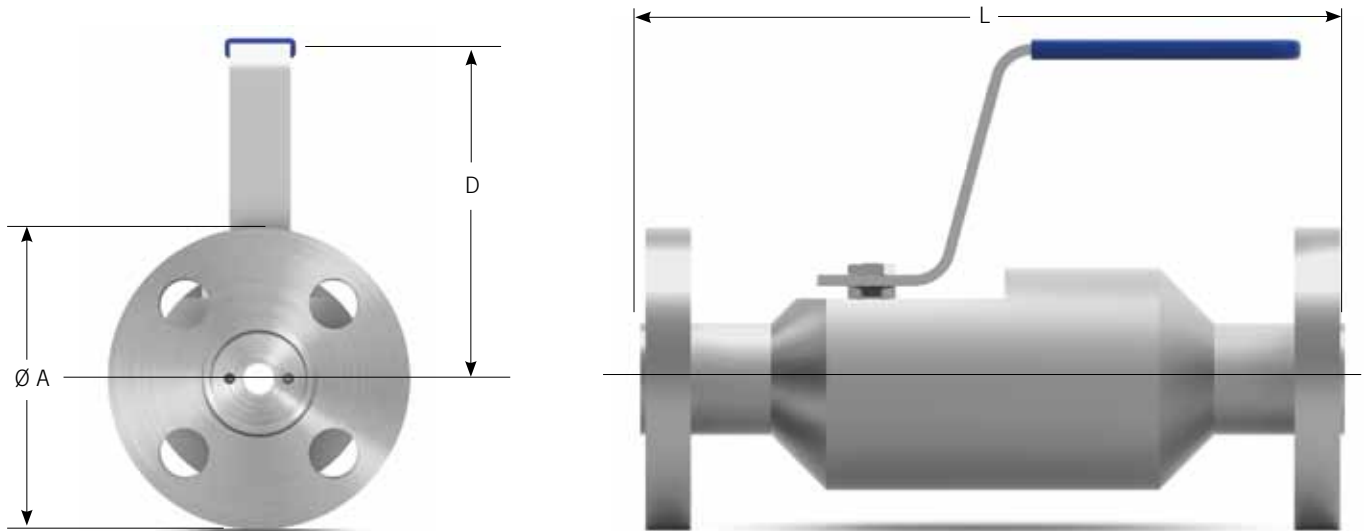

Flange Size	B16.34 Pressure Class	RF Double Flange (10mm)				RTJ Double Flange (10mm)			
		A	D	L	Weight	A	D	L	Weight
1/2"	150	3.50	4.3	8.5	12	NA	NA	NA	NA
1/2"	300	3.75	4.3	8.7	13	3.75	4.3	9.1	13
1/2"	600	3.75	4.3	9.2	13	3.75	4.3	9.2	14
1/2"	900/1500	4.75	4.3	9.9	18	4.75	4.3	9.9	19
1/2"	2500	5.25	4.3	10.5	23	5.25	4.3	10.5	25
3/4"	150	3.88	4.3	8.6	13	NA	NA	NA	NA
3/4"	300	4.62	4.3	8.9	16	4.62	4.3	9.2	16
3/4"	600	4.62	4.3	9.4	16	4.62	4.3	9.4	16
3/4"	900/1500	5.12	4.3	10.1	21	5.12	4.3	10.1	22
3/4"	2500	5.50	4.3	10.6	26	5.50	4.3	10.6	27
1"	150	4.25	4.3	8.7	14	4.25	4.3	9.1	15
1"	300	4.88	4.3	9.0	15	4.88	4.3	9.4	17
1"	600	4.88	4.3	9.5	17	4.88	4.3	9.5	18
1"	900/1500	5.88	4.3	10.4	26	5.88	4.3	10.4	27
1"	2500	6.25	4.3	10.9	33	6.25	4.3	10.9	34
1-1/2"	150	5.00	4.3	9.0	17	5.00	4.3	9.4	18
1-1/2"	300	6.12	4.3	9.2	22	6.12	4.3	9.6	24
1-1/2"	600	6.12	4.3	9.9	25	6.12	4.3	9.9	26
1-1/2"	900/1500	7.00	4.3	10.6	36	7.00	4.3	10.6	38
1-1/2"	2500	8.00	4.3	11.6	57	8.00	4.3	11.7	61
2"	150	6.00	4.3	9.1	21	6.00	4.3	9.5	23
2"	300	6.50	4.3	9.4	25	6.50	4.3	9.9	27
2"	600	6.50	4.3	10.1	29	6.50	4.3	10.2	31
2"	900/1500	8.50	4.3	11.1	56	8.50	4.3	11.2	59
2"	2500	9.25	4.3	12.1	81	9.25	4.3	12.2	85

HBA2 10mm Ball Valve - Double Flange

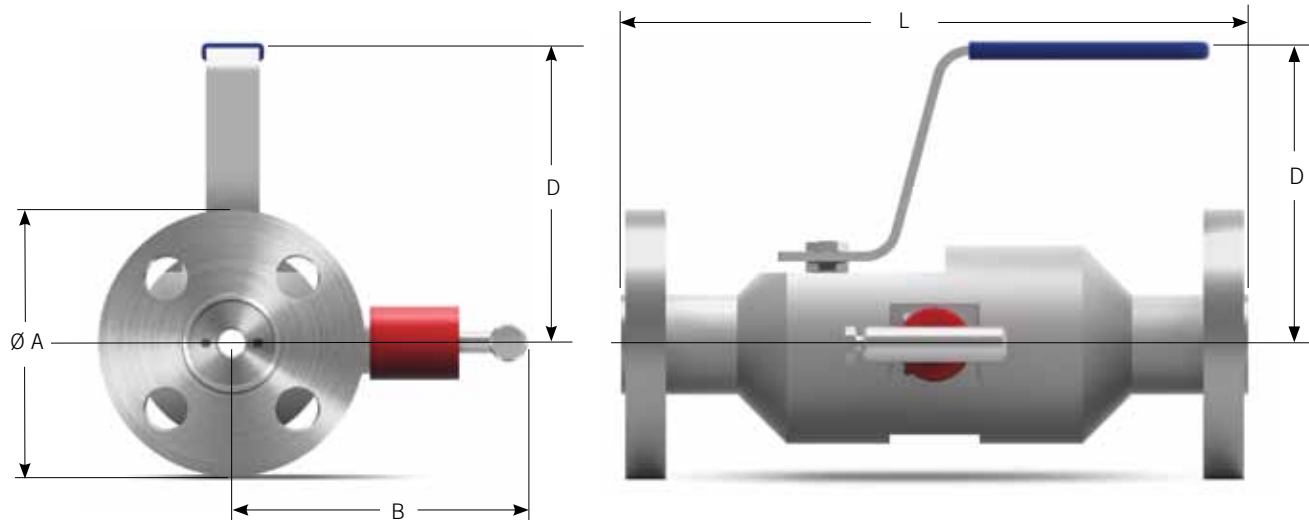

Flange Size	B16.34 Pressure Class	RF Double Flange (10mm)					RTJ Double Flange (10mm)				
		A	B*	D	L	Weight	A	B	D	L	Weight
1/2"	150	3.50	4.0	4.3	8.5	12	N/A	N/A	N/A	NA	NA
1/2"	300	3.75	4.0	4.3	8.7	13	3.75	4.0	4.3	9.1	13
1/2"	600	3.75	4.0	4.3	9.2	13	3.75	4.0	4.3	9.2	14
1/2"	900/1500	4.75	4.0	4.3	9.9	18	4.75	4.0	4.3	9.9	19
1/2"	2500	5.25	4.0	4.3	10.5	23	5.25	4.0	4.3	10.5	25
3/4"	150	3.88	4.0	4.3	8.6	13	N/A	N/A	N/A	NA	NA
3/4"	300	4.62	4.0	4.3	8.9	16	4.62	4.0	4.3	9.2	16
3/4"	600	4.62	4.0	4.3	9.4	16	4.62	4.0	4.3	9.4	16
3/4"	900/1500	5.12	4.0	4.3	10.1	21	5.12	4.0	4.3	10.1	22
3/4"	2500	5.50	4.0	4.3	10.6	26	5.50	4.0	4.3	10.6	27
1"	150	4.25	4.0	4.3	8.7	14	4.25	4.0	4.3	9.1	15
1"	300	4.88	4.0	4.3	9.0	15	4.88	4.0	4.3	9.4	17
1"	600	4.88	4.0	4.3	9.5	17	4.88	4.0	4.3	9.5	18
1"	900/1500	5.88	4.0	4.3	10.4	26	5.88	4.0	4.3	10.4	27
1"	2500	6.25	4.0	4.3	10.9	33	6.25	4.0	4.3	10.9	34
1-1/2"	150	5.00	4.0	4.3	9.0	17	5.00	4.0	4.3	9.4	18
1-1/2"	300	6.12	4.0	4.3	9.2	22	6.12	4.0	4.3	9.6	24
1-1/2"	600	6.12	4.0	4.3	9.9	25	6.12	4.0	4.3	9.9	26
1-1/2"	900/1500	7.00	4.0	4.3	10.6	36	7.00	4.0	4.3	10.6	38
1-1/2"	2500	8.00	4.0	4.3	11.6	57	8.00	4.0	4.3	11.7	61
2"	150	6.00	4.0	4.3	9.1	21	6.00	4.0	4.3	9.5	23
2"	300	6.50	4.0	4.3	9.4	25	6.50	4.0	4.3	9.9	27
2"	600	6.50	4.0	4.3	10.1	29	6.50	4.0	4.3	10.2	31
2"	900/1500	8.50	4.0	4.3	11.1	56	8.50	4.0	4.3	11.2	59
2"	2500	9.25	4.0	4.3	12.1	81	9.25	4.0	4.3	12.2	85

*When fully open.

Sample Quills & Injection Probes

- The Sampling Probe or Injection Quill Double Block and Bleed valves are designed for safety in these hazardous applications.
- Integral check valve available.
- Custom designs and lengths available per customer application.

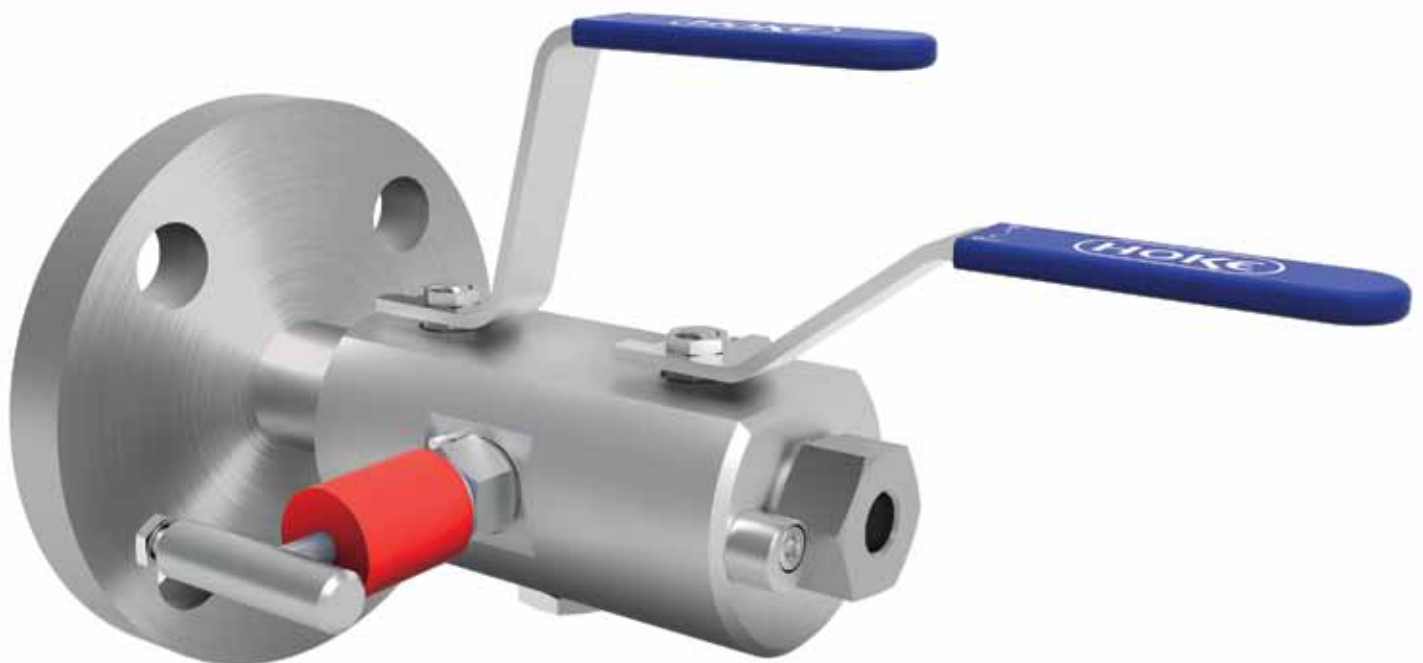

Materials of Construction - HOKE® Block - Ball Valve

Item	Description	316 SS	Carbon Steel	Exotic Alloy
1	Body	316L SS / 316L SS NACE	A105 / A105 NACE (Note)	Exotic
2	Ball	316L SS / 316L SS NACE	316 SS/316 SS NACE	Exotic
3	Ball Stem	316L SS / 316L SS NACE	316 SS/316 SS NACE	Exotic
4	Ball Stem Packing	PTFE or Graphite	PTFE or Graphite	PTFE or Graphite
5	Ball Stem O-ring	Viton®	Viton®	Viton®
6	Seats	PEEK or Carbon PEEK	PEEK or Carbon PEEK	PEEK or Carbon PEEK
7	Gasket-Metal	316L SS / 316L SS NACE	316 SS/316 SS NACE	Exotic
8	Gasket-Soft	PEEK or Carbon PEEK	PEEK or Carbon PEEK	PEEK or Carbon PEEK
9	Handle	316 SS	316 SS	316 SS
10	Inlet Retainer	316L SS / 316L SS NACE	A105 / A105 NACE (Note)	Exotic
11	Outlet Retainer	316L SS / 316L SS NACE	A105 / A105 NACE (Note)	Exotic
12	Bleed Bonnet	316L SS / 316L SS NACE	316 SS/316 SS NACE	Exotic

Note: Carbon steel valve bodies and components are zinc plated

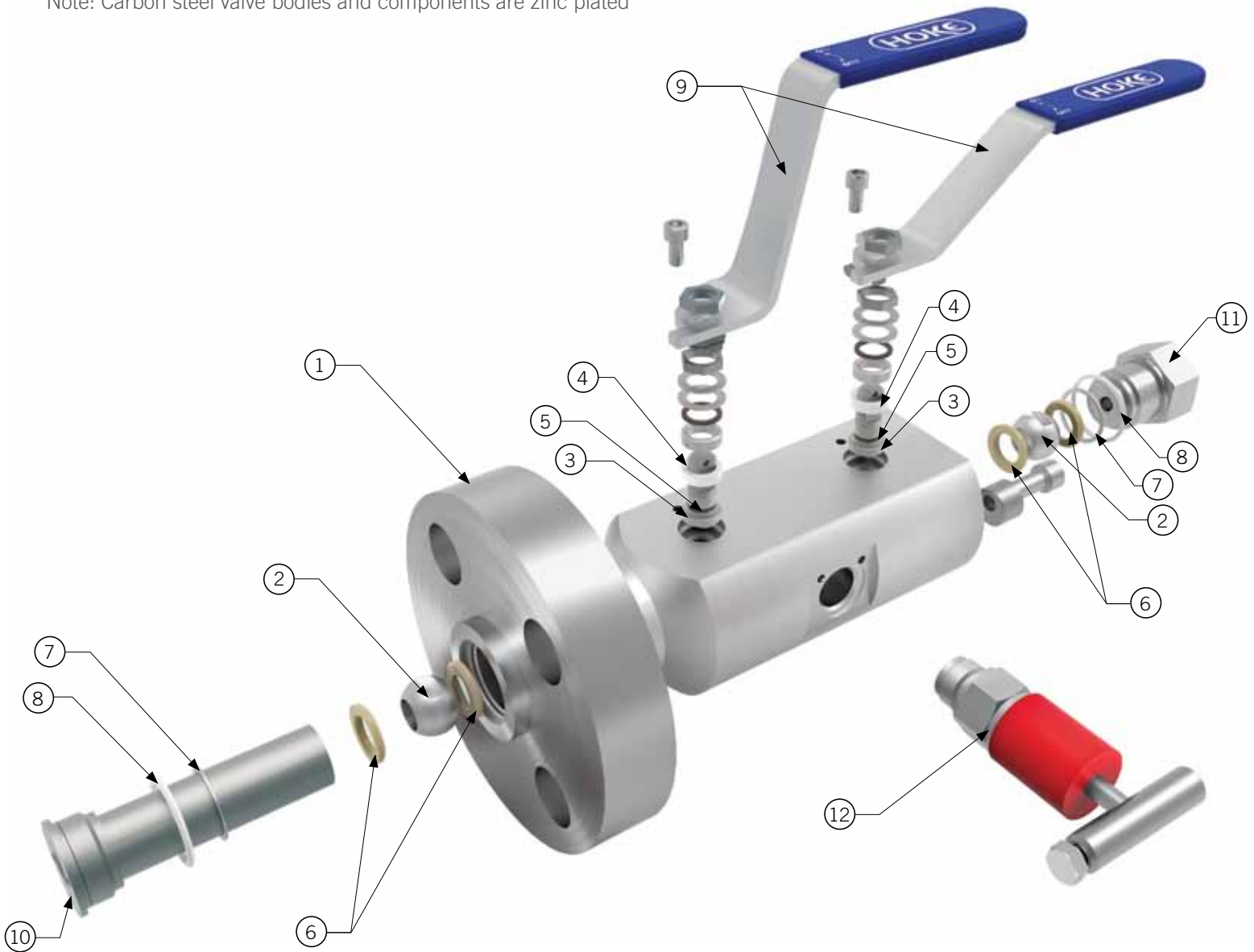

API 6A Flanged HOKE® Blocks - Double Block & Bleed

- Flange sizes of 1-13/16", 2-1/16", and 2-9/16"
- Flange types 2,000, 3,000, 5,000, and 10,000 API.
- API 607 6th addition fire safe.
- Heavy duty HOKE® valve non-rotating tip designed needle valve.
- 10mm and 15mm bore sizes are available.
- Single or double flange configurations are available.
- Large variety of materials are available (Stainless Steel, Duplex, Super-Duplex, ICONEL®, etc.)



Dimensions (API 1-13/16" 10,000 PSI Flange x 1/2" FNPT Shown)

Weight = 28lbs

