

# Energy Core Ventilators Model MiniCore and ECV Preconditioners



Greenheck's MiniCore and ECV models are air-to-air energy recovery ventilators that utilize total energy core technology to reduce your building's heating and cooling loads on mechanical equipment. The MiniCore will provide your building with preconditioned, fresh outdoor air for indoor commercial applications from 150 to 1,000 cfm. The model ECV is a solution available for indoor and outdoor commercial applications from 500 to 3,750 cfm.



**Model MiniCore**



**Model ECV**

Features	Benefits
<p><b>Industry Leading Selection Software (CAPS®)</b></p>	<p>CAPS®, Greenheck's computer-aided product selection software, analyzes system design parameters quickly and provides a list of units with energy core and fan combinations. This reduces design time, minimizes cost and optimizes performance. The program outputs fan, electrical, and energy core performance data, as well as configuration-specific 2D and 3D drawings for easy implementation into building schedules and plans.</p>
<p><b>Compliance with Industry Standards</b></p>	<p>Code officials recognize the benefits of utilizing energy recovery in applications with large amounts of ventilation air. Greenheck's third party certification for energy core performance (AHRI) verifies the units provide the mandated energy recovery effectiveness per ASHRAE standards and energy codes.</p>
<p><b>Maintenance/Serviceability</b></p>	<p>Greenheck's preconditioners have been designed to allow easy access to filters, blower assemblies and energy cores. As reassurance to the customer, each unit carries a one year warranty and each energy core carries a five year warranty.</p>
<p><b>System Efficiency/Payback</b></p>	<p>The incorporation of energy recovery allows for equipment downsizing as well as continued lower energy costs throughout the life of the equipment. This downsizing moderates the variability of loads on the system, increasing the efficiency of furnaces, electric heaters, DX coils and water systems.</p>

## Product Certifications

Greenheck takes pride in offering a high-quality, reliable product. We invest our resources into designing, testing and manufacturing products to ensure customer satisfaction.



ETL Listed for electrical and overall unit safety. Every unit is tested at the factory before it is shipped to the jobsite.



Energy recovery cores are certified by the AHRI Air-to-Air Energy Recovery Ventilation Equipment Certification Program in accordance with AHRI Standard 1060. Actual performance in packaged equipment may vary. Certified ratings are available in the Certified Product Directory at [www.ahridirectory.org](http://www.ahridirectory.org).

## How does energy recovery work?

Energy recovery is the process through which energy is transferred between the conditioned return air from the space and the fresh outdoor air which imposes the load on mechanical equipment.

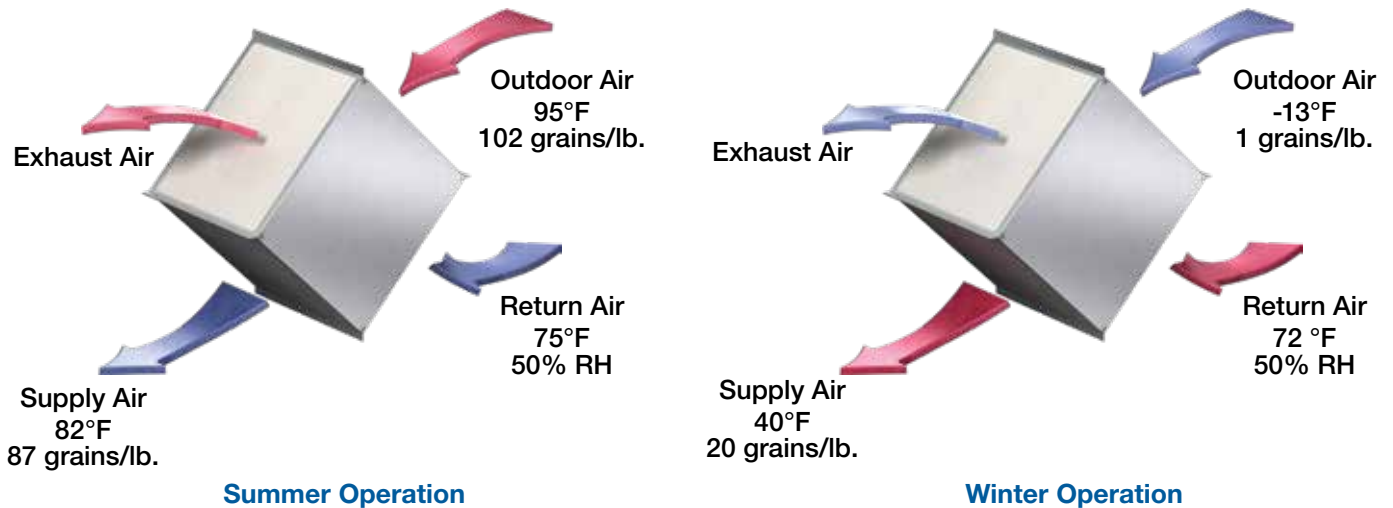

## Energy Core Technology

The total energy core is offered in a fiber or polymer membrane, layered in a cross-flow corrugated structure. The core is designed to separate the supply and exhaust airstream, ensuring that only fresh air is introduced into the indoor space. The fiber and polymer membrane media transfers both sensible energy (heat) and latent energy (moisture). When supply and exhaust airflows are balanced, energy cores have an enthalpy recovery ratio (ERR) of up to 60%.

Fiber Membrane (-FM)	Polymer Membrane (-PM)
MiniCore and ECV	ECV Only
Vacuum Cleanable	Washable
Airflows up to 3,300 cfm	Airflows up to 3,750 cfm
Economic Offering	Reduced pressure drop
0-1% Exhaust Air Transfer Ratio (EATR)	

## ASHRAE 90.1 Compliance

ASHRAE 90.1-2016 (Table 6.5.6.1) requires the use of energy recovery based upon a unit's supply airflow, outdoor air percentage, geographic location and application operating hours. The standard mandates that the ERR be a minimum of 50%. This language was adopted in the 2018 International Energy Conservation Code (IECC).

The effectiveness of an energy recovery device will vary based on the type, material, and supply/exhaust airflows. This value is determined based on a test procedure outlined in the Air Conditioning, Heating, and Refrigeration Institution (AHRI) Standard 1060. All Greenheck energy cores are third party certified to AHRI 1060.

## Typical Applications for Energy Recovery

- Churches
- Locker Rooms
- Dormitories
- Nursing Homes
- Function Halls
- Schools
- Office Buildings
- Hospitals

## Energy Recovery with Ducted Air Handlers

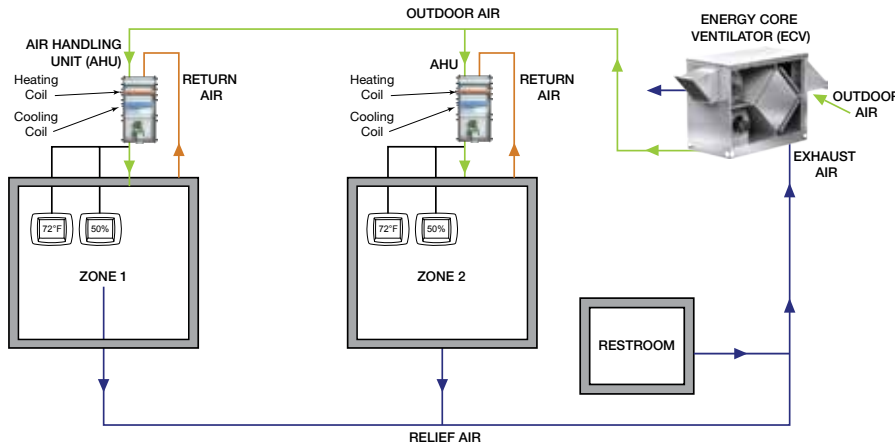

### Preconditioner Applications

These diagrams illustrate how energy recovery units can be used in conjunction with other HVAC equipment. Fresh, outdoor air enters the energy recovery unit and is pretreated before entering the heating and cooling equipment.

Whether ducting into terminal units, such as air handlers, or directly feeding into a rooftop unit, these preconditioners provide the ability to reduce the outdoor air load of these systems.

## Energy Recovery with Packaged Rooftop Equipment

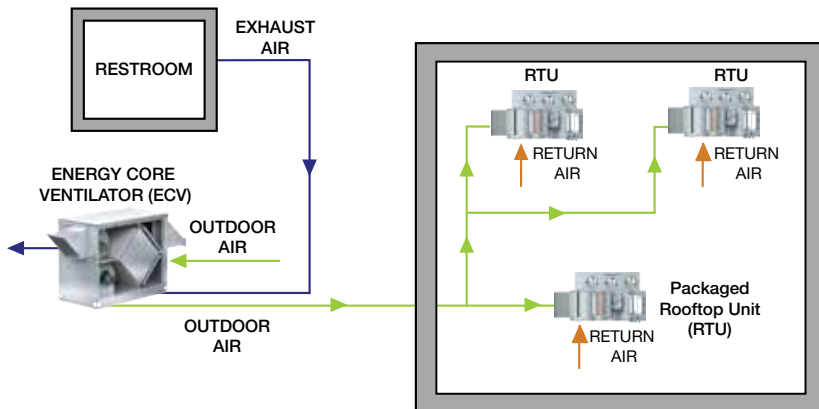

### Recovering Restroom Exhaust

ASHRAE Standard 62.1 dictates that energy recovery devices rated for less than 10% cross-contamination can return restroom exhaust through the device. Any volume of air transferred through the device can be reclassified as fresh outdoor air. All of Greenheck's energy recovery units are rated well below the 10% limit, therefore it is allowable to return restroom exhaust, and is also recommended to maximize the benefit.

## Energy Recovery with Variable Air Volume

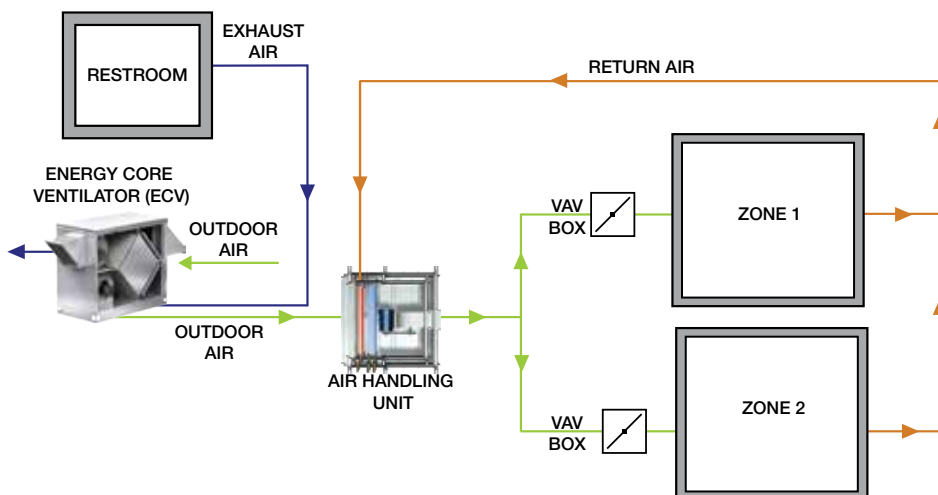

Models MiniCore-5 and MiniCore-10 are energy recovery ventilators that will provide your building with pre-conditioned fresh outdoor air for applications ranging from 150 to 1,000 cfm. Designed for compact indoor installations, the MiniCore can mount in any orientation, providing a ventilation solution for individual spaces, such as school classrooms, dormitories, offices, nursing homes and locker rooms. Vari-Green® electronically commutated (EC) motors provide an additional energy savings with highly efficient motor technology. Two removable panels on the unit provide easy access to filters, blowers, and the total energy core technology.

Model	A	B	C	D	Approx. Weight (lbs.)	Airflow Range (cfm)
MiniCore-5	47.3	16.3	39.4	34.4	215	150 - 700
MiniCore-10	47.3	21.5	39.4	34.4	245	500 - 1,000

All dimensions shown in inches.

## Configuration and Mounting Options

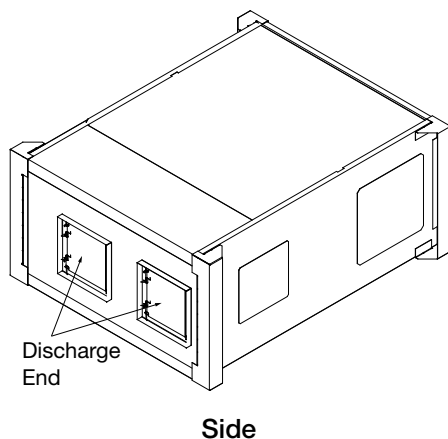
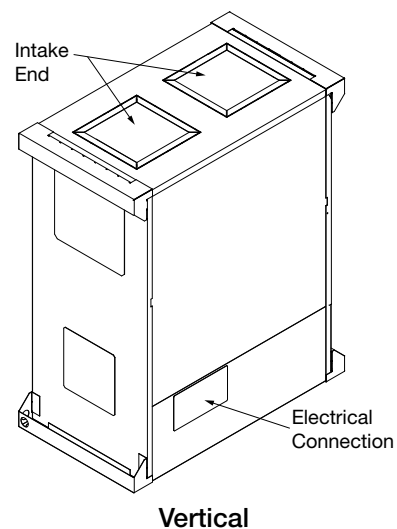
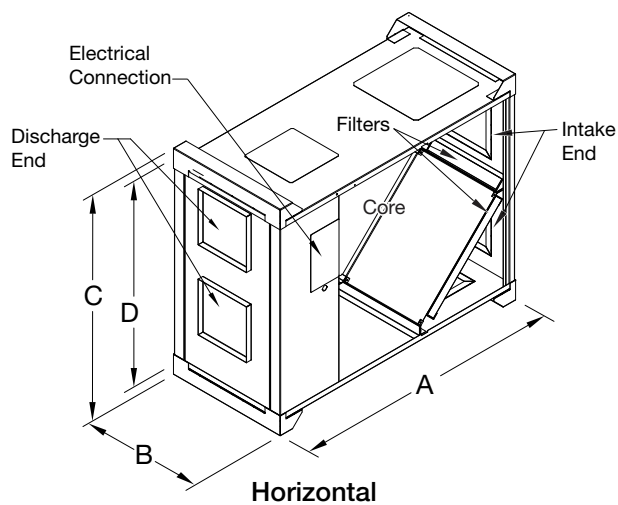

**Model Number Code**

**MiniCore - 5 - VG - FM**

Model Parent Vari-Green® Nominal Airflow 5 (500 cfm) 10 (1,000 cfm)	Core Type FM - Fiber
---------------------------------------------------------------------------------	-------------------------

## Optional Control Sequences and Product Features

### Energy Core Frost Control

The frost control prevents frost buildup on the energy core in climates that have cold outdoor winter temperatures, typically less than -10°F, and/or moist indoor conditions such as gym locker rooms.

Available option:

- **Timed exhaust** - Cycles supply blower to melt frost with warm return air.

### Vari-Green® EC Motor

Features a soft start, overload protection, locked rotor protection, thermal protection and easy RPM adjustment through a motor potentiometer or 0-10 VDC signal.



Model ECV is designed for indoor and outdoor mounting for commercial and institutional applications requiring 500 to 3,750 cfm of ventilation air. Unit comes standard with a fiber membrane (FM) energy core and has an optional polymer membrane (PM) energy core for increased efficiency, lower pressure drop, and washability. Vari-Green® electronically commutated (EC) motors provide additional energy savings and easy RPM adjustment on Model ECV-10.

Model		A	B	C	Approx. Weight (lbs.)	Airflow Range (cfm)
ECV-10	FM	54.8	28.9	43.9	485	500 - 1,000
	PM					500 - 1,300
ECV-20	FM	65	43.9	56.9	816	750 - 2,200
	PM					750 - 2,750
ECV-30	FM	69	61.4	60.7	1,286	1,200 - 3,300
	PM					1,200 - 3,750

All dimensions shown in inches.

## Configuration Options

### Indoor Configurations

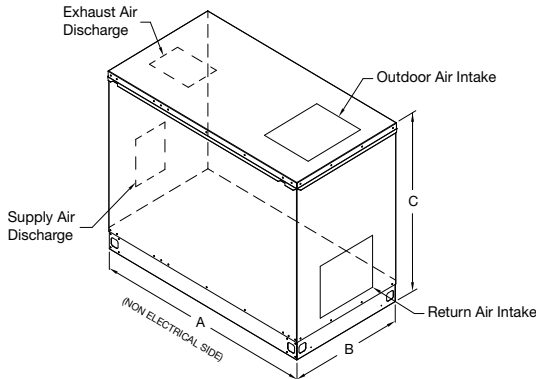

### Top and End Connections

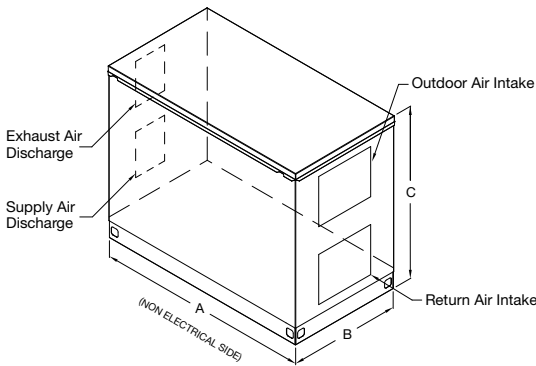

### End Connections

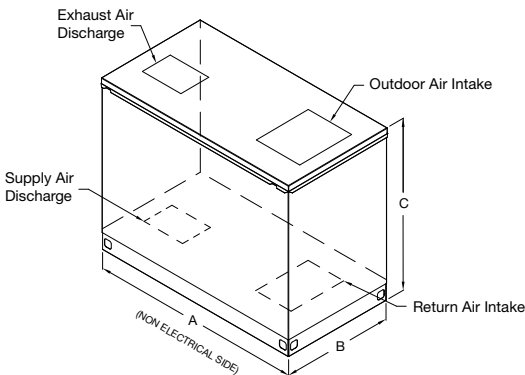

### Top and Bottom Connections

### Outdoor Configurations

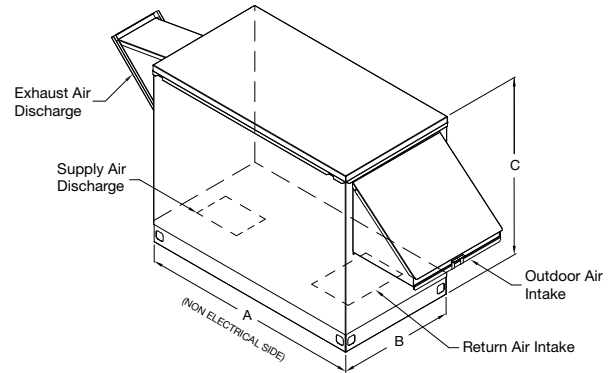

### Outdoor Air Discharge Bottom

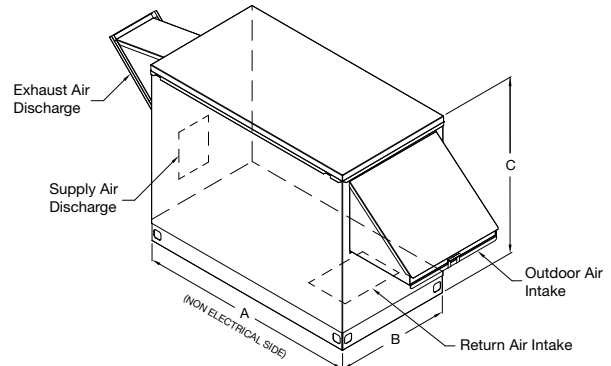

### Outdoor Air Discharge End

### Model Number Code

ECV - 10 - H - VG - FM

<p><b>Model Parent</b></p> <p><b>Nominal Airflow</b></p> <p>10 (1,000 cfm)</p> <p>20 (2,200 cfm)</p> <p>30 (3,300 cfm)</p>	<p><b>Airflow Rate</b></p> <p>H - High</p> <p>L - Low</p>	<p><b>Core Type</b></p> <p>FM - Fiber</p> <p>PM - Polymer</p> <p><b>Vari-Green®</b></p> <p>ECV-10</p>
----------------------------------------------------------------------------------------------------------------------------	-----------------------------------------------------------	-------------------------------------------------------------------------------------------------------

## Optional Control Sequences and Product Features

### Economizer Control

When outdoor air conditions are favorable, the controller will allow the economizer operation based off of a temperature or enthalpy. Available options are:

- **Bypass damper** - An integral bypass damper will cycle open, allowing approximately 50% of the incoming cool air to flow past the energy recovery core and enter the building unconditioned.
- **Exhaust only operation** - Unit will have the capability to receive an external signal to power off the supply fan.



### Energy Core Frost Control

The frost control prevents frost buildup on the energy core in climates that have cold outdoor winter temperatures, typically less than -10°F, and/or moist indoor conditions such as gym locker rooms. Available options are:

- **Timed exhaust** - Cycles supply blower to melt frost with warm return air.
- **Electric preheater** - Preheats outdoor air to avoid frosting.

### Vari-Green® EC Motor

Available on ECV-10

Features a soft start, overload protection, locked rotor protection, thermal protection and easy RPM adjustment through a motor potentiometer or 0-10 VDC signal.



### Demand Control Ventilation

Varies the amount of outdoor air based on occupancy. Available options are:

- **CO<sub>2</sub> sensor** - Mounted in the return air duct or in the space, this sensor determines occupancy and modulates the fan speed accordingly or it cycles the unit on and off to provide the appropriate amount of outdoor air.
- **Time clock** - A remote panel can be equipped with a 7-day programmable time clock to turn the unit on or off based on a schedule.



### Fan Speed Control

Available on ECV-20 and ECV-30

To accommodate the system requirements, the fan speed can be adjusted with a variable frequency drive. Available options are:

- **Multi-speed** - Allows the fan to operate at three preset speeds determined by a set of input contacts (provided by others).
- **Modulating** - Varies the fan speed from 50-100% based on an analog input signal (0-10 VDC).

## Unit Control Options

In addition to standard analog control, Greenheck is proud to offer the following direct digital control option.

### Microprocessor

The microprocessor controller is factory-programmed, wired and tested prior to shipment. The controller can operate stand-alone or integrate with a Building Management System (BMS) using BACnet® MSTP or IP or Modbus RTU or IP protocols.

Control Features:

- LCD display
- Built-in keypad for easy set point adjustment
- Integral 7-day time clock
- Optional remote display for service convenience
- Built-in frost and economizer controls
- Supply and exhaust fan modulation capabilities
- Monitoring points for temperature and/or relative humidity
- Web user interface



# Additional Energy Recovery Preconditioners



## Model MiniVent

The compact design of this preconditioner provides an economical solution for individual spaces such as school classrooms and small offices. Airflow capacities range from 150 to 850 cfm.



## Model ERV

This preconditioner is designed for floor-mounted or ceiling-hung installation in commercial and institutional applications. Airflow capacities range from 500 to 12,000 cfm.



## Model ERVe

Designed for outdoor-mounted commercial and institutional applications requiring 1,000 to 6,000 cfm of ventilation air. The configurability of this unit allows for easy incorporation on rooftops or outdoor pad mounting scenarios.



## Model ERM

Designed for new construction or retrofit applications where an energy recovery ventilator may not meet space requirements. This indoor modular energy recovery device is capable of handling 600 to 10,000 cfm of ventilation air.

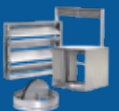

## Our Commitment

*As a result of our commitment to continuous improvement, Greenheck reserves the right to change specifications without notice.*

Product warranties can be found online at [Greenheck.com](http://Greenheck.com), either on the specific product page or in the literature section of the website at [Greenheck.com/Resources/Library/Literature](http://Greenheck.com/Resources/Library/Literature).