



—MODEL— **CRL-60**

Pressure Relief Control

DESCRIPTION

The CRL-60 Pressure Relief Control is a direct acting, spring loaded, diaphragm type relief valve. It may be used as a self-contained valve or as a pilot control for a Cla-Val Main valve. It opens and closes within very close pressure limits.

INSTALLATION

The CRL-60 Pressure Relief Control may be installed in any position. The control body (1) has one inlet and one outlet port. Body (1) also has smaller side ports; one on inlet, one on outlet, each with pipe plugs (23) installed. These smaller side ports are used for control connections or gauge applications. The body (1) also has one center side port, used as the sensing line port. A flow arrow is marked on the body casting.

OPERATION

The CRL-60 Pressure Relief Control is normally held closed by the force of the compression spring above the diaphragm; control pressure is applied under the diaphragm.

When the controlling pressure exceeds the spring setting, the disc is lifted off its seat, permitting flow through the control.

When controlling pressure drops below spring setting, the spring returns the control to its normally closed position.

ADJUSTMENT PROCEDURE

The CRL-60 Pressure Relief Control can be adjusted to provide a relief setting at any point within the range found on the nameplate.

Pressure adjustment is made by turning the adjustment screw (11) to vary the spring pressure on the diaphragm. Turning the adjustment screw clockwise increases the pressure required to open the valve. Counterclockwise decreases the pressure required to open the valve.

When pressure adjustments are complete the jam nut (10) should be tightened and the protective cap (12) replaced. If there is a problem of tampering, lock wire holes have been provided in cap and cover. Wire the cap to cover and secure with lead seal.

DISASSEMBLY

The CRL-60 Pressure Relief Control does not need to be removed from the line for disassembly. Make sure that pressure shut down is accompanied prior to disassembly. If the CRL-60 is removed from the line for disassembly be sure to use a soft jawed vise to hold body during work.

Refer to Parts List Drawing for Item Numbers.

1. Remove cap (12), loosen jam nut (10) and turn adjusting screw counterclockwise until spring tension is relieved.
2. Remove the eight screws (15) holding the cover (9). Keep the cover and eight screws together and place on a suitable work surface. See NOTE under REASSEMBLY.
3. Remove the cover (9) from body (1). The spring (8) and two spring guides (7).
4. Remove plug (22) from body (1). Using screwdriver, hold stem assembly (4) to remove nut (13).
5. Slide off the Belleville washer (14), upper diaphragm washer (18), diaphragm (17) and lower diaphragm washer (19).
6. Remove stem guide (21) from body (1). Remove stem assembly (4). Inspect, replace stem assembly and/or O-rings (5), (6) and (20) if necessary. Use soft jawed pliers or vise to hold stem. The polished surface of stem must not be scored or scratched.
7. The seat (3) need not be removed unless it is damaged. If removal is necessary use proper size socket wrench and turn counterclockwise.

INSPECTION

Inspect all parts for damage, or evidence of cross threading. Check diaphragm for tears. Check stem assembly (4) for abrasions or other damage. Check all metal parts for damage, corrosion or excessive wear.

REPAIR AND REPLACEMENT

Minor nicks and scratches may be polished out using 400 grit wet or dry sandpaper fine emery or crocus cloth. Replace all O-rings and any damaged parts.

When ordering replacement parts, be sure to specify parts list item number and all nameplate data.

REASSEMBLY

In general, reassembly is the reverse of disassembly. However, the following steps should be observed:

1. Lubricate the O-Ring (5) and (6) with a small amount of a good grade of waterproof grease, (Dow Corning 44 medium grade or equal). Use grease sparingly when installing O-ring (20) into guide stem (21).
2. Install stem assembly (4) into guide stem (21). Use a rotating motion with minimum pressure to let stem pass through O-ring. Do Not Cut O-Ring.
3. Install O-ring (6) at top of stem assembly (4). Install guide stem (21) and stem assembly (4) into body (1). Use socket to tighten securely. Place lower diaphragm washer (19) on the stem assembly with the serrated side up. Position diaphragm (17), upper diaphragm washer (18), with serration down, and Belleville washer (14) with concave side down.
4. Install nut (13) and tighten securely.
5. Continue reassembly as outlined in disassembly steps 1 through 3.

SYMPTOM	PROBABLE CAUSE	REMEDY
Fails to open.	Controlling pressure too low.	Back off adjusting screw until valve opens.
Fails to open with spring compression removed.	Mechanical obstruction, corrosion, scale build-up on stem.	Disassemble, locate, and remove obstruction, scale.
Leakage from cover vent hole when controlling pressure is applied.	Diaphragm Damage	Disassembly replace damaged diaphragm.
	Loose diaphragm assembly.	Tighten upper diaphragm washer.
Fails to close.	No spring compression.	Re-set pressure adjustment.
Fails to close with spring compressed.	Mechanical obstruction.	Disassemble, locate and remove obstruction.



CRL-60

1/2" & 3/4" PRESSURE RELIEF CONTROL

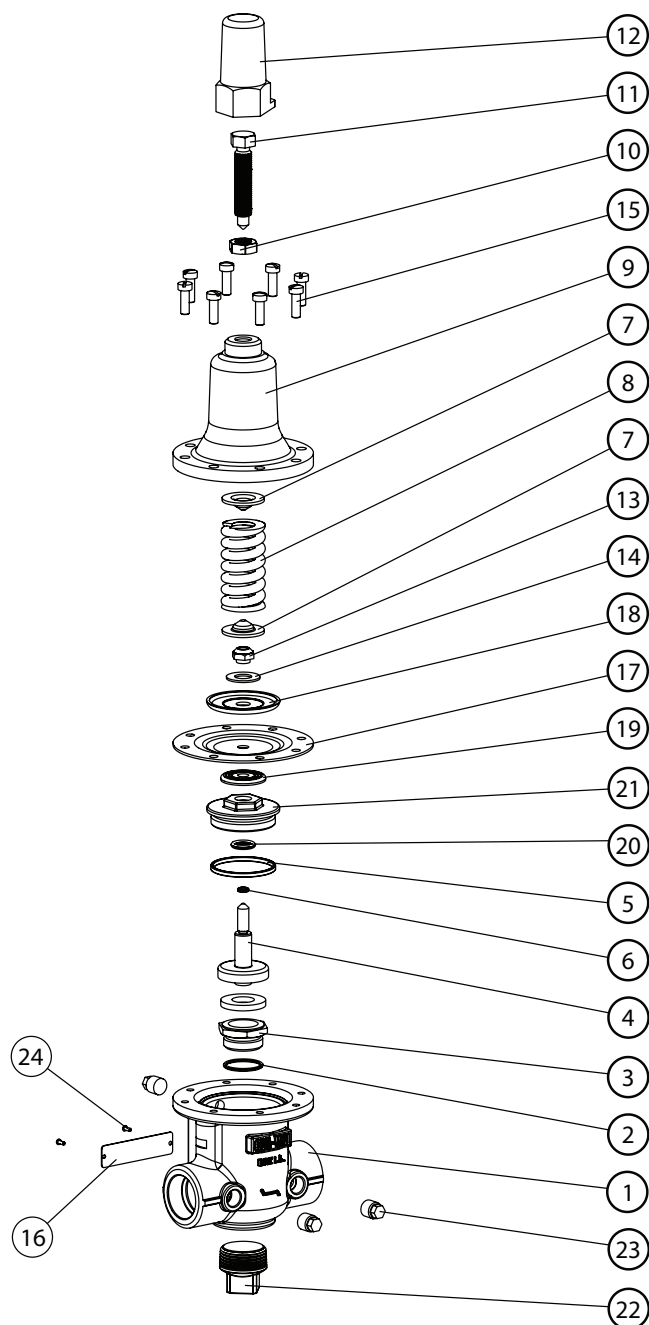

Item	Description	Quantity
1	BODY	1
* 2	O-RING	1
3	SEAT 1/2" & 3/4"	1
* 4	STEM ASSEMBLY	1
* 5	O-RING	1
* 6	O-RING	1
7	Guide Spring	2
8	SPRING	1
9	COVER	1
10	Hexnut .375--16 UNC	1
11	Adjusting Screw	1
12	Cap	1
13	NUT, STEM	1
14	BELLEVILLE WASHER FLAT	1
15	FIL HD SCREW #10--32 UNF	8
16	NAMEPLATE	1
* 17	DIAPHRAGM	1
18	Washer Diaphragm Upper	1
19	DIAPHRAGM WASHER	1
* 20	O-RING	1
21	GUIDE STEM	1
22	3/4" NPT PIPE PLUG	1
23	1/8" NPT PIPE PLUG	3
24	DRIVE SCREW	2

* SUGGESTED REPAIR PARTS REPAIR KIT;
1/2" & 3/4".....P/N 9170033G

Size	Spring	Part Number
1/2"	0 - 75 PSI	20840401A
1/2"	20 - 105 PSI	20840408D
1/2"	20 - 200 PSI	20840402K
1/2"	†100 - 300 PSI	20861201J
3/4"	0 - 75 PSI	20840403J
3/4"	20 - 200 PSI	20840404H
3/4"	†100 - 300 PSI	20861202H
1"	20 - 75 PSI	20944105K
1"	20 - 400 PSI	20944106J
1"	100 - 300 PSI	20944107H

for 250 - 600 PSI, Consult Factory

†The 100-300 PSI spring requires a larger cover than the other CRL-60 springs.

When ordering parts please specify:

1. All Nameplate Data
2. Item Part Number
3. Item Description

CRL-60 Spring Range PSI	APPROX. INCREASE FOR EACH CLOCKWISE TURN OF ADJUSTING SCREW
0 to 75	8.5 PSI
20 to 75	6.0 PSI
20 to 105	12.5 PSI
20 to 200	28.0 PSI
40 to 200	18.0 PSI
100 to 300	18.0 PSI

