

## ► Power from Flowing Water

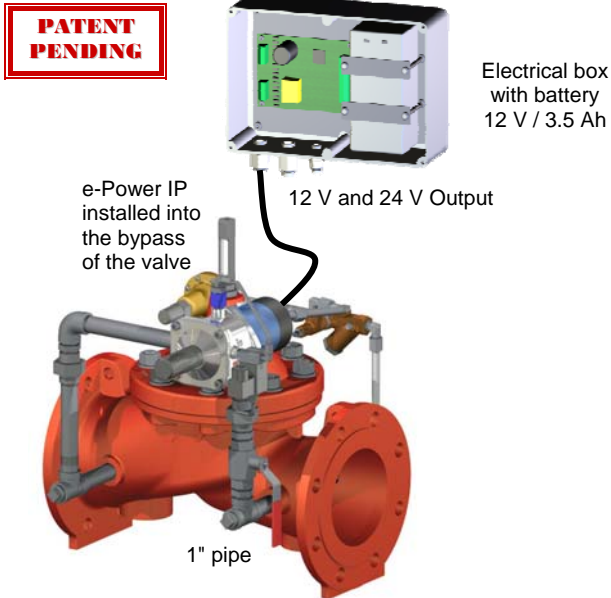

The e-Power IP combines an electrical generator, a solenoid bypass shut-off allowing a complete stop of the e-Power IP and a hydraulic differential pressure controller.

The electrical box combines a 12 V / 3.5 Ah rechargeable battery and an electronic charge management system.

Battery	Voltage
Lead acid 3.5 Ah	12 V
Lead acid 3.5 Ah (step-up)	24 V

## ► Description

- The e-Power IP uses the pressure drop across the valve to produce 16 W of power
- Autonomous low voltage system combined with a 12 V-24 V / 3.5 Ah lead battery
- Only requires a Differential pressure of 6 mhd with a Flow of 50 l/min

The CLA-VAL e-Power IP is an electrical generator using available hydraulic energy directly from the water distribution network. The e-Power IP is installed into the bypass of the CLA-VAL valve.

The e-Power IP powers various devices located within close proximity of the valve or on the valve itself, e.g. motorised pilots, sensors, telemetry, PLC or HMI interfaces.

At the optimum operating point of the turbine, (dP = 6 mhd and Q = 50 l/min), the rechargeable battery delivers the following output voltage, current and power:

Output voltage	Amps Continuous (60 min/h)	Amps Low peak (10 min/h)	Amps High peak (1 min/h)
12 V	1.16 A 14 W	3 A 36 W	5 A 60 W
24 V (step-up)	0.58 A 14 W	1.5 A 36 W	2.5 A 60 W

## ► Performance curves of the turbine

The electrical power produced by the turbine recharges the 12 V / 3.5 Ah battery. The power (W) to charge the battery is the multiplication of the current (A) and voltage (V).

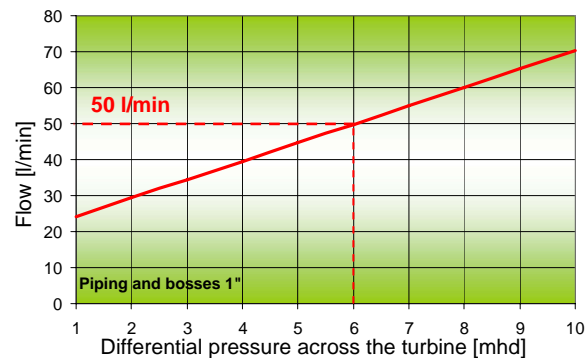
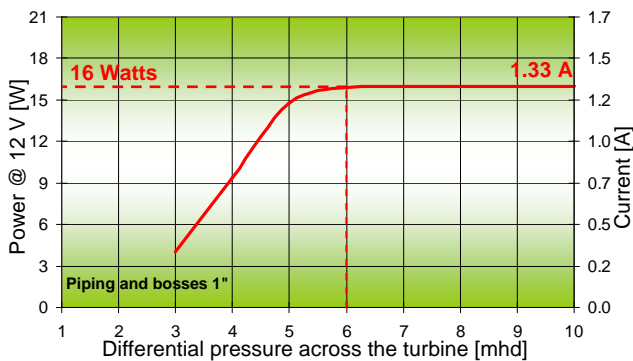

### Note:

- (1) For main valve Inlet and Outlet bosses tapped 3/4" or 1/2" combined with 1" bypass piping, 3 mhd or 4 mhd respectively should be added to obtain the total differential pressure (Inlet - Outlet pressure) of the valve. Example: 3/4" valve bosses with 1" bypass piping 3 mhd + 6 mhd = A total of **9 mhd differential pressure across the valve** to reach the maximum turbine power of 16 W.
- (2) For main valve Inlet and Outlet bosses tapped 1", combined with 3/4" or 1/2" bypass piping, 6 mhd or 8 mhd respectively should be added to obtain the total differential pressure (Inlet - Outlet pressure) of the valve. Example: 1" valve bosses with 3/4" bypass piping 6 mhd + 6 mhd = A total of **12 mhd differential pressure across the valve** to reach the maximum turbine power of 16 W.

## ► e-Power IP hydraulic operation

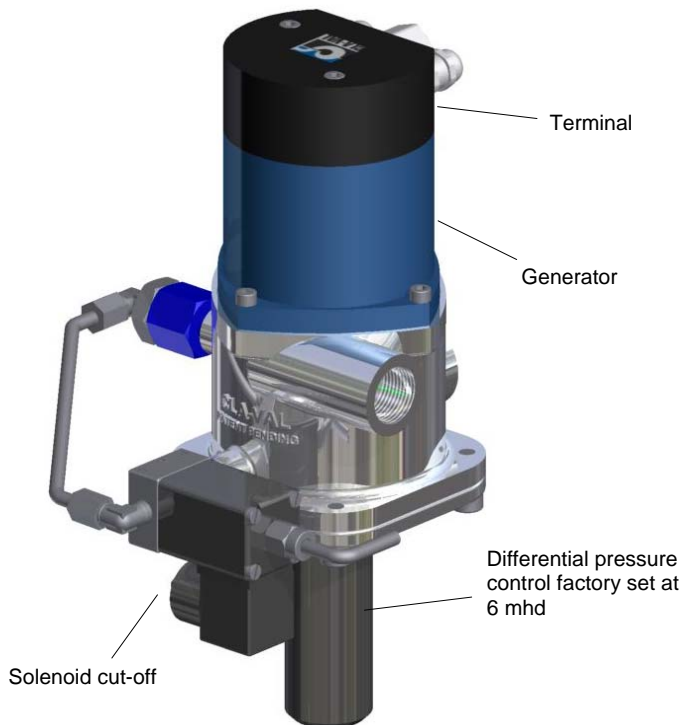

### Differential pressure control

The e-Power IP incorporates a mechanical differential pressure limiter. This limiter controls the differential pressure across the e-Power IP which in turn controls the electrical power produced.

The management of differential pressure and the production of energy within a single compact product is an innovative and patented design from CLA-VAL.

### Bypass cut-off

A “cut-off” bistable solenoid attached is to the body of the e-Power IP.

When the solenoid switches, the upper diaphragm assembly chamber connects to atmosphere and stops the water from flowing through the turbine. Without differential pressure across the turbine the e-Power IP is no longer producing energy.

The bypass cut-off is initiated when the battery is fully charged and avoids any downstream overpressure.

### Diaphragm assembly

The diaphragm assembly is the moving part which regulates the e-Power IP in order to maintain a constant differential pressure across the turbine. The diaphragm assembly is hydraulically balanced.

The differential pressure control is factory set at 6 mhd.

On each side of the diaphragm are two chambers, the lower and upper chamber:

- The lower diaphragm assembly chamber is connected to the wheel chamber (upstream wheel pressure).
- The upper diaphragm assembly chamber is connected to the wheel outlet (downstream wheel pressure).

When the upstream pressure entering the e-Power IP increases, the lower chamber pressure moves the diaphragm assembly upwards to throttle the water leaving the outlet of the chamber and vice versa.

### Regulating assembly

The stem located at the end of the diaphragm assembly is the disc-guide. This behaves like a regulating valve controlling excess hydraulic energy.

The disc-guide closes the diaphragm assembly onto a seat machined directly in the e-Power IP body.

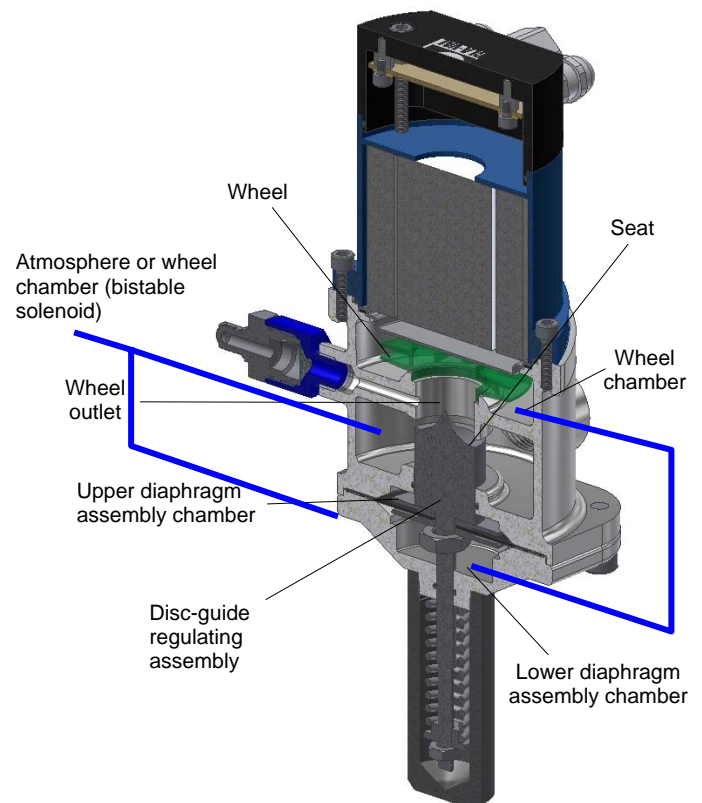

## ► e-Power IP electrical operation

### Electrical box assembly and mounting

The electrical box contains the printed circuit board (PCB) and a rechargeable battery.

The PCB is factory wired. The user wires the output voltage 12 V and/or 24 V only.

The battery alarm level is a dry contact switch which closes when a preset critical voltage is reached (factory preset at 11.5 V).

Fitted with factory rechargeable battery. This is a gel type lead acid battery and totally maintenance-free.

The three stator generator and bi-stable solenoid mounted on the turbine body are connected to the generator terminal. As an option a second bi-stable solenoid can also be connected to the same terminal.

This second solenoid enables, for example, a valve to fully open when the turbine has completed the battery charging cycle (CLA-VAL 250-03 is a typical valve requiring this option).

## ► Battery cycles

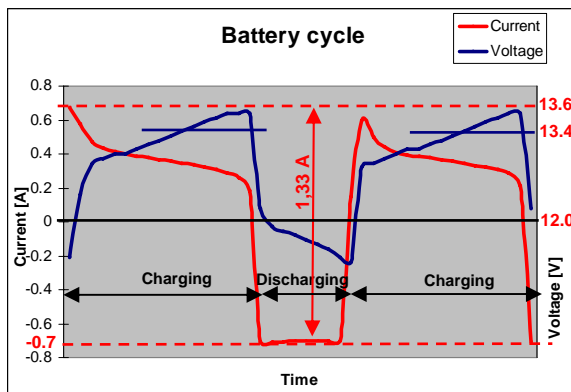

The charging cycle starts when the battery level reaches 12.0 V. At 13.6 V the charging cycle stops. To ensure a full charge of the battery, an additional one hour charging mode starts automatically at 13.4 V (factory set).

During the battery charging cycle the current is plotted as positive, in discharge mode (or draw) the current is shown negative.

The total maximum current amplitude is 1.33 A. This value is always the maximum potential power delivered by the turbine (16 W) divided by voltage 16 W: 12 V = 1.33 A.

In this example the total continuous consumption (or draw) is 0.7 A or 12 V x 0.7 A = 8.4 W power consumption (or draw).

### Typical e-Power IP assembly

The e-Power IP can be assembled in different configurations: directly factory build on the valve, field retrofit or wall bracket mounted.



CLA-VAL's quality factory assembly is constructed using either totally rigid piping or lower pressured braided steel armoured hose similar to the field retrofit. Typical piping diameter is 3/4" or 1" depending on the valve size.

CLA-VAL's quality field retrofit includes a mounting kit, piping and fittings. CLA-VAL provides standard retrofit kits for all valve sizes. Kits are designed for simple and easy on site assembly.



CLA-VAL's quality wall mounted bracket allows the e-Power IP to be used on any type of hydraulic valve or fitting, assuming that the minimum hydraulic differential pressure and flow conditions are available.



The wall mounted bracket is installed and secured by only two screws. Minimum site operation and effort allows a very easy installation for the user.

In some special cases, where minimum flow ranges are below 50 l/min, a pressure reducer model CLA-VAL AQUA 80-451 installed on the bypass piping of the valve is required to avoid any downstream overpressure. Please consult factory for any low flow application.

### ► Electrical management

**Programming the battery charge:** CLA-VAL e-Power IP is factory-set and fully programmed therefore the user has a total calibration-free product.

The voltage charge-discharge cycle range is defined between 12.0 V and 13.6 V.

Time based programming associated with the battery cycle allows a "preventive" charge of the battery (standard preset charge period is 05:00 and 17:00). This ensures total charge of the battery if the hydraulic system has to be stopped or differential pressure is reduced due to higher water consumption.

**Power management:** The electrical power output changes depending on system conditions (see performance curves of the turbine). 3 mhd differential pressure generates 4 W power, and 6 mhd differential generates 16 W. The maximum differential pressure across the turbine is factory-set at 6 mhd. A sophisticated algorithm, called «Maximum Power Point Tracker (MPPT)», adjusts voltage and current to continuously generate maximum power charge. As voltage generated by the turbine, varies greatly with daily differential pressure conditions, the MPPT algorithm 'tracks' and optimises delivered output power.

**Battery characteristics:** The lead acid waterproof battery VRLA (Valve Regulated Lead Acid) is build according to IEC 60896-2 standard for trouble-free transportation including rail, road, sea and air transportation in accordance with IATA, DGR clause A67.

Lifetime (20°C) is between 5 and 7 years according to the type of use (after 2000 cycles remaining capacity is 80%). Shipped factory charged the discharge rate is approximately 2% per month for a period of 24 months (20°C) allowing prolonged storage prior use. Battery is completely recyclable.

**Printed Circuit Board (PCB):** Designed with the latest technology and manufactured from high quality electronic components the PCB is fully tropical coated to ensure maximum humidity protection.

Communication (option) through a serial port allows continuous monitoring of the voltage, charging current and consumption (draw) current.

On site: communication protocol CLA-VAL-USB or Modbus. Remotely: interface modem GSM and/or GPRS (protocol TCP-IP/FTP, TCP-IP/Modbus and TCP-IP/CLA-VAL).

Programming Interface and Graph of the e-Power IP behaviour (only for factory use)

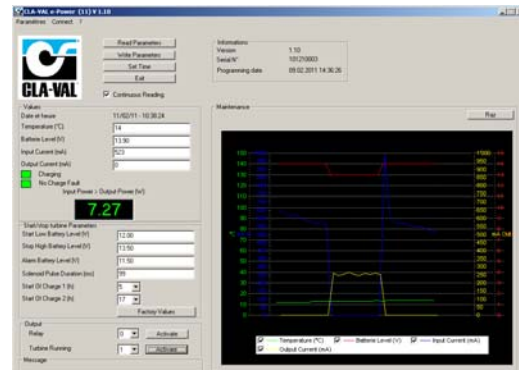

### ► Technical Data:



Battery:



Power protection:

Output 12 VDC:

Output 24 VDC:  
(step-up)

Battery alarm output:

Operating display:

Electrical connection:

Temperature range:



Operating pressure:

Valve size and model  
(mm):  
(Piping ¾" : P- ¾")  
(Piping 1" : P- 1")

Software interface:

Protection:

Strainer:

#### Electrical Specification

- 12 V / 3.5 Ah
- Gelled lead acid waterproof battery VRLA, maintenance free
- Battery fully recyclable
- Maximum operating temperature 55°C
- Reverse polarity & short circuit
- 80°C stop high temperature
- A continuous 60 min/h **1.16 A** (14 W)
- A low peak 10 min/h **3 A** (36 W)
- A high peak 1 min/h **5 A** (60 W)
- A continuous 60 min/h **0.58 A** (14 W)
- A low peak 10 min/h **1.5 A** (36 W)
- A high peak 1 min/h **2.5 A** (60 W)
- Dry contact switch
- Charging: LED flashing red
- Discharging: LED flashing green
- Moulded 3 meters cable
- - 10°C to + 80°C (PCB only)

#### Other Specifications

- PFA 10 bar
- NGE DN 100 bosses tapped Rp ½" - P ¾"
- NGE DN 125-200 bosses tapped Rp ¾"- P ¾"
- NGE DN 250-600 bosses tapped Rp 1" - P-1"
- GE/AE DN 65-80 bosses tapped Rp ½" - P ¾"
- GE/AE DN 100-150 bosses tapped Rp ¾"-P ¾"
- GE/AE DN 200-400 bosses tapped Rp1"-P-1"
- Plug & play / NT / 2000 / XP / Vista / Windows 7 (32 & 64 bit)
- IP 68 (excluding solenoid)
- For solenoid, Screen 0.2 mm

## ► Typical applications for the CLA-VAL SERIES e-Power IP

### Powering the CLA-VAL SERIES CPC

The e-Power IP provides electrical power for autonomous operation of valves when controlled by a CLA-VAL CPC hydraulic position control.

The CLA-VAL SERIES CPC is a range of valves equipped with a motorised hydraulic positioner controlled via a 4-20 mA command signal. The CLA-VAL SERIES CPC can be programmed to regulate pressure, flow or tank level by adjusting the position of the valve over its entire stroke from fully open to fully closed position.

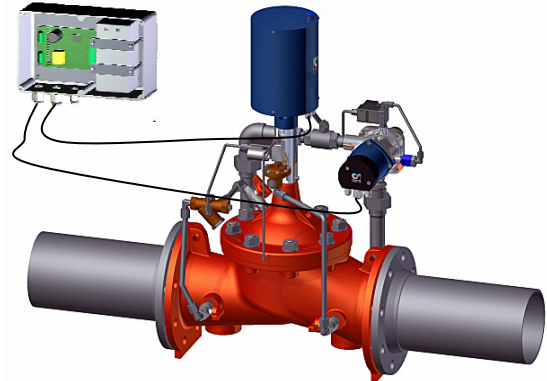

### Powering the CLA-VAL SERIES PCM

The e-Power IP provides electrical power for autonomous operation of valves when controlled by a CLA-VAL e-Drive-33 actuated pilot control.

The CLA-VAL SERIES PCM combines a hydraulic pilot with an integral controller (e-Drive-33) allowing a remote set-point command (4-20 mA) input for smooth pilot remote adjustment. This simple remote changing of a valve set-point is suitable for many applications where the process variable is monitored separately and a SCADA, or similar remote control system, provides valve feedback and control.

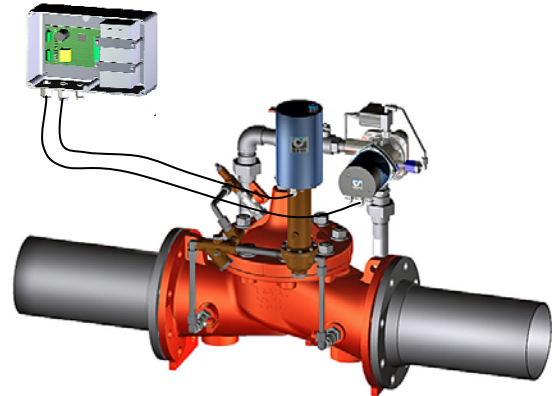

### Powering remote control system, SCADA system

The e-Power IP provides electrical power for independent remote management system 12 V or 24 V to overcome battery life environmental issues.

The autonomy of the system allows sites to be managed remotely.

The use of data acquisition systems for the management of water systems is increasingly popular. With this in mind, CLA-VAL has created the e-Power IP system to allow an electrical system to run autonomously.

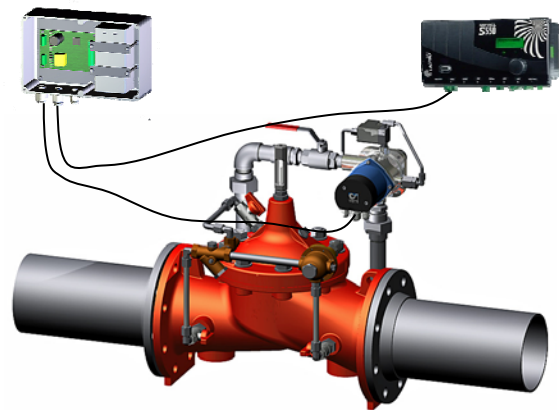

### Powering flow meters, sensors and data loggers

The e-Power IP provides electrical power for independent electrical power supply to all monitoring devices such as electronic flow meters, loggers, pressure sensors and remote low voltage GSM-GPRS systems.

Systems automated through HMI interfaces can be powered by an e-Power IP to facilitate the management of a remote hydraulic site.

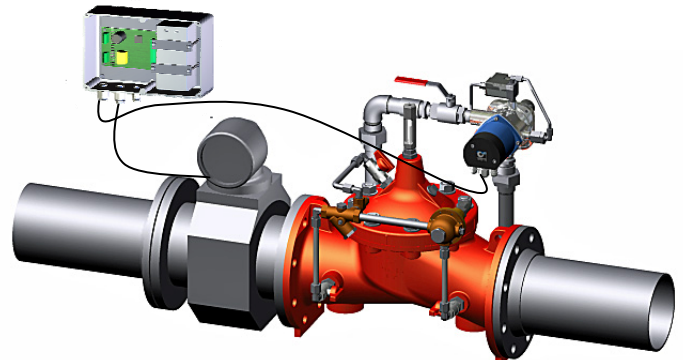

## ► How to Order an e-Power IP?



FM version



RM version



WM version

<b>300041</b>	Main family product number			Number
	<b>FM</b>	Factory mounted (turbine + electronic box + 3 meters cable)		Mounting version
	<b>RM</b>	Retrofit kit mounted (turbine + electronic box + 3 meters cable)		
	<b>WM</b>	Wall mounted (same as FM/RM + bracket + screws)		
		<b>L03</b>	3 meters cable (turbine to junction box)	Electrical cable
		<b>L10</b>	10 meters cable (turbine to junction box)	
		<b>N100</b>	NGE 100 mm (tubing/fitting 3/4" size)	Valves model and DN
		<b>N125</b>	NGE 125 mm (tubing/fitting 3/4" size)	
		<b>N150</b>	NGE 150 mm (tubing/fitting 3/4" size)	
		<b>N200</b>	NGE 200 mm (tubing/fitting 3/4" size)	
		<b>N250</b>	NGE 250 mm (tubing/fitting 1" size)	
		<b>N300</b>	NGE 300 mm (tubing/fitting 1" size)	
		<b>N400</b>	NGE 400 mm (tubing/fitting 1" size)	
		<b>N500</b>	NGE 500 mm (tubing/fitting 1" size)	
		<b>N600</b>	NGE 600 mm (tubing/fitting 1" size)	
		<b>G065</b>	GE 65 mm (tubing/fitting 3/4" size)	
		<b>G080</b>	GE 80 mm (tubing/fitting 3/4" size)	
		<b>G100</b>	GE 100 mm (tubing/fitting 3/4" size)	
		<b>G150</b>	GE 150 mm (tubing/fitting 3/4" size)	
		<b>G200</b>	GE 200 mm (tubing/fitting 1" size)	
		<b>G250</b>	GE 250 mm (tubing/fitting 1" size)	
		<b>G300</b>	GE 300 mm (tubing/fitting 1" size)	
		<b>G400</b>	GE 400 mm (tubing/fitting 1" size)	
		<b>XXX</b>	Without downstream pressure control (AQUA 80-451)	Option
		<b>DPC</b>	With downstream pressure control (AQUA 80-451)	
		<b>R</b>	ISO 7-1 (turbine tapping Rp 3/4")	Tapered thread
		<b>For WM code</b>	<b>T02</b>	Pressure steel wire armored hose (for WM version)
			<b>TXX</b>	
			2x 2 meters pressure steel wire armored hose size 3/4" or 1" depending on DN	
			For longer supply line contact CLA-VAL	

<b>300041</b>	<b>RM</b>	<b>L10</b>	<b>N250</b>	<b>XXX</b>	<b>R</b>	<b>300041-RM-L10-N250-XXX-R-TXX</b>	Example No.
---------------	-----------	------------	-------------	------------	----------	-------------------------------------	-------------

**Example customer choice:** e-Power IP, for retro fit kit, with 10 meters cable between turbine to junction box, for valve type NGE 250 mm, without downstream pressure control and ISO 7-1 thread. **300041-RM-L10-N250-XXX-R**

⚠ Spare parts or mounting tools are not included.

► How to Order an e-Power IP?

No. CLA-VAL	CLA-VAL Model		
*CKEIP-STD-01	Including diaphragm, spring and o-rings		Turbine repair kit
970699	12 V / 3.5 Ah		Lead acid battery
MEXSILIC-01	10 g		Silica gel crystal sachet
58960	Without electric cables		e-Power IP turbine with solenoid
*CKEIP-STD-02	With 4 screws and 4 anchors		Wall bracket plate for e-Power IP
Contact CLA-VAL	1 meter 1", with connections + 1 meter additional hose 1" 1 meter (3/4", with connections) + 1 meter additional hose 3/4"		Pressure steel wire armored hose

«CLA-VAL Sales Conditions and Warranty» (document 000001DE) applies until otherwise agreed.