

Centrifugal Upblast & Sidewall Exhaust Models CUBE, CUE, CWB, CW and USGF

- General Clean Air • Restaurant Grease
- High Wind • Seismic • Smoke Control • Contaminants



 **VARI-GREEN.**

Performance data now included.

 **GREENHECK**
Building Value in Air.



BUILDING VALUE IN AIR.

November
2018

Models CUE, CUBE, CW, CWB, USGF

Centrifugal Exhaust Fans

Roof Upblast and Sidewall



Table of Contents

Model Comparison 3

Standard Construction Features 4-5

Applications:

- General Clean Air 6
- Restaurant Grease 6
- Heavy Grease 6
- Emergency Smoke Control 7
- Seismic 7
- High Wind & Hurricane 8
- Severe Duty Roof Curbs 9

Vari-Green Options:

- Vari-Green® Motor 10
- Vari-Green® Controls 11
- Vari-Green® Drive 12
- Options and Accessories 13-14
- Typical Installations 15-16
- Performance and Dimensions:

 - Model Number Code 17
 - Performance Pages 18-49

- Typical Specifications 50-55
- Quick Build Program 56
- Our Commitment 56



- CUBE, CUE, CWB, and CW models are Listed for Electrical (UL/cUL 705) File no. E40001
- CUBE, CWB, USGF and models CUE and CW sizes 099 and larger are Listed for Grease Removal (UL/cUL 762) File no. MH11745
- CUBE and USGF models are Listed for Emergency Smoke Control Systems (UL/cUL Listed for 500°F (260°C) for 4 hours and 1,000°F (538°C) for 15 minutes) File no. MH17511

Note: UL/cUL is optional and must be specified

Model sizes CUBE-099, 161XP, 240XP, 300HP & 300XP are excluded from Emergency Smoke Control.



Modes CUE, CUBE, CW, CWB, and USGF meet CE (Conformité Européenne).



Greenheck Fan Corporation certifies that the Model CUBE, CUE, CWB, CW and USGF shown herein are licensed to bear the AMCA Seal. The ratings shown are based on tests and procedures performed in accordance with AMCA Publication 211 and Publication 311 and comply with the requirements of the AMCA Certified Ratings Program. The certified ratings for Model CUBE, CUE, CWB, CW and USGF, are shown on pages 18-49.

Enjoy Greenheck's extraordinary service, before, during and after the sale.

Greenheck offers added value to our wide selection of top performing, energy-efficient products by providing several unique Greenheck service programs.

- Our Quick Delivery Program ensures shipment of our in-stock products within 24 hours of placing your order. Our Quick Build made-to-order products can be produced in 1-3-5-10-15 or 25-day production cycles, depending upon their complexity.
- Greenheck's free Computer Aided Product Selection program (CAPS), rated by many as the best in the industry, helps you conveniently and efficiently select the right products for the challenge at hand.
- Greenheck has been Green for a long time! Our energy-saving products and ongoing corporate commitment to sustainability can help you qualify for LEED credits.
- Our 3D service allows you to download, at no charge, easy-to-use AutoDesk® Revit® 3D drawings for many of our ventilation products.

Find out more about these special Greenheck services at greenheck.com



Models CUE, CUBE, CW, CWB, USGF

Centrifugal Exhaust Fans

Roof Upblast and Sidewall



Model Comparison																										
Model	Location		Mounting				Airflow				Application						Drive Type		Impeller Type			Performance				
	Outdoor	Indoor	Roof Curb	Base/Floor	Hanging	Wall	Ceiling Mounted	Exhaust	Supply	Reversible	Recirculate	General/Clean Air	Contaminated Air	Spark Resistant	Grease (UL 762)	Smoke Control (UL)	High Wind (150 mph)	High Temp (above 200°F)	Seismic Certification	Belt	Direct	Centrifugal	Propeller/Axial	Mixed Flow	Maximum Volume (cfm)	Maximum Static Pressure (in. wg)
CUE	✓		✓				✓				✓	✓	✓	✓		✓	✓	✓		✓	✓				14,700	3
CW	✓					✓	✓				✓	✓	✓	✓		✓	✓	✓		✓	✓				6,400	3
CUBE	✓		✓				✓				✓	✓	✓	✓	✓	✓	✓	✓	✓			✓			30,000	5
CWB	✓					✓	✓				✓	✓	✓	✓		✓	✓	✓	✓	✓		✓			12,450	2.75
USGF	✓		✓				✓				✓	✓		✓	✓	✓	✓	✓	✓			✓			6,800	3.25

When you buy a Greenheck roof upblast or sidewall exhaust fan, you'll receive a fan with the industry's best performance and durability for general clean air, restaurant grease, smoke control, light contaminants, seismic, high wind, and hurricane applications. Both roof upblast and sidewall configurations are specifically designed to discharge air directly away from the mounting surface.

- Performance as cataloged is assured. All fan sizes are tested in our AMCA Accredited Laboratory and all models are licensed to bear the AMCA Sound and Air Performance seal.
- UL/cUL Listed for Electrical, Grease and Smoke Control.
- Greenheck subjects these products to extensive life testing, assuring you the fans will provide many years of reliable performance.



LEED information

Greenheck became one of the first manufacturers in the Air Movement and Control industry to join the LEED/green movement when they joined the United States Green Building Council (USGBC) in 2005. Greenheck has been actively researching qualification requirements for our products to meet LEED credits and prerequisites.



The Vari-Green® motor significantly helps qualification efforts for the Energy and Atmosphere credits and prerequisites; specifically credit one, Optimize Energy Performance and prerequisite two, Minimum Energy Performance.

Standard Construction Features

Standard Construction Features		CUE CUBE	CW CWB	USGF
1	Wheel	✓	✓	✓ *Non-Stick, Steel
2	Vibration Isolation	✓	✓	✓
3	Disconnect Switch	✓	✓	
				✓
4	Bearings	✓	✓	✓
5	Fan Shaft	✓	✓	✓
6	Drive Assembly	✓	✓	✓
7	Motor Cover	✓	✓	✓ *Steel
8	Stainless Steel Fasteners	✓	✓	✓
9	Windband	✓	✓	✓ *Steel
10	Motor	✓	✓	✓
11	Motor Cooling Tube	✓	✓	✓
12	Internal Supports	✓	✓	✓
13	Leakproof Construction	✓	✓	✓
14	Curb Cap with Mounting Holes	✓	✓	✓ *Steel
15	Drain Trough	✓		✓
16	Galvanized Mounting Plate		✓	
17	Galvanized Birdscreen		✓	
18	Nameplate	✓	✓	✓
Not Shown	Internal Conduit Chase	✓	✓	

*Differences from the standard construction feature.

Standard Construction Features

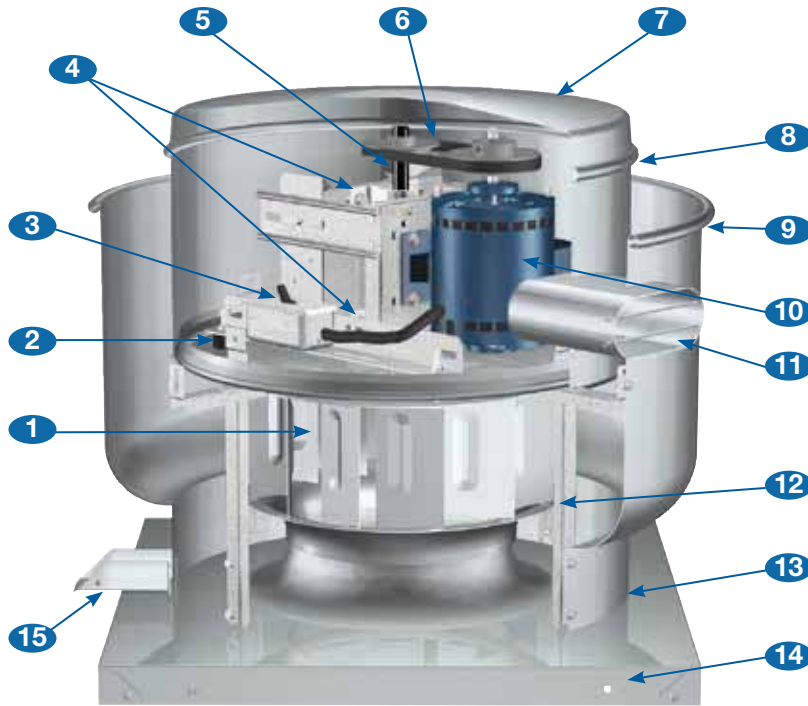

Models CUBE and CUE



Models CW & CWB

Standard Construction Features - Continued			CUE CUBE	CW CWB	USGF
19	Dual Drives	Oversized 150%, adjustable, static-free and oil-resistant.			✓
Not Shown	Hinged Curb Base with Cables	Allows maintenance personnel to gain access to wheel and ductwork for regular inspection and cleaning by utilizing the hinged curb base with cables.			✓
20	Clean-Out Port	Allows the entire centrifugal wheel to be easily cleaned through a 4-inch diameter hole on outside of the fan windband. Meets NFPA 96 standard.			✓
21	Permatector™ Coating	Typically used for applications that require corrosion resistance in indoor and outdoor environments.			✓
22	Lifting Points	Various lifting points located on the drive frame and bearing plate.	✓	✓	✓

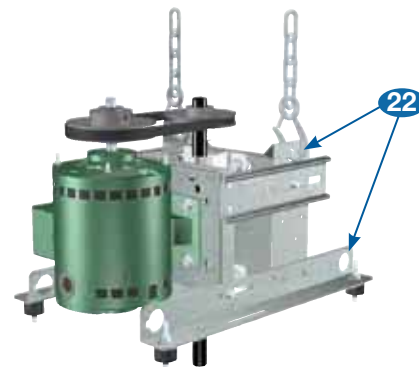
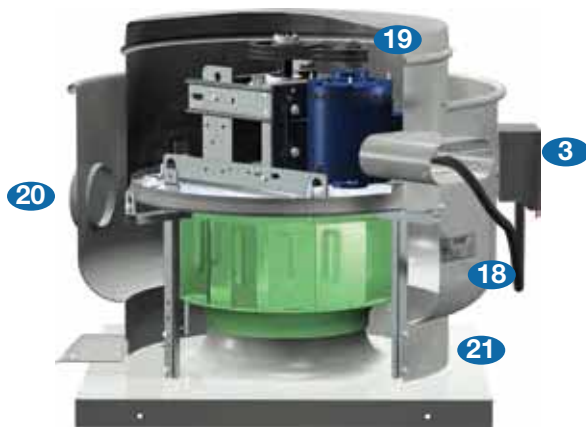

Model USGF



Clean Air Applications

Models CUE, CUBE, CW and CWB

These spun aluminum fans are specifically designed for roof mounted or wall mounted applications. General clean or lightly contaminated exhaust air can be discharged directly upward, away from the roof surface or discharged out and away from building walls.

- Most advanced motor cooling of any fan in its class.
- One-piece windband, continuously welded to the curb cap, ensures leak-proof construction for the life of the fan.
- Performance as cataloged is assured. All fan sizes are tested in our AMCA Accredited Laboratory and all models are licensed to bear the AMCA Sound and Air Performance seal.
- Greenheck subjects these products to extensive life testing, assuring you the fans will provide many years of reliable performance.



Restaurant and Grease Applications

Models CUE, CUBE, CW and CWB

When you choose a Greenheck fan, you have selected a fan with the industry's best performance and durability for restaurant and grease applications. Spun aluminum exhaust fans, models CUBE, CWB and models CUE and CW sizes 099 and larger, are specifically designed for use in restaurant applications to discharge air directly away from the mounting surface.

- Most advanced motor cooling of any fan in its class.
- One-piece windband, continuously welded to the curb cap, ensures leak-proof construction for the life of the fan.
- UL/cUL 762 Listed for exhausting restaurant grease exhaust.

Ultimate Steel Grease Fan for Heavy Grease Applications

Model USGF

Fan model USGF is the industry's best for performance and durability for heavy grease applications. This spun steel exhaust fan is specifically designed to remove large amounts of grease and/or contaminants associated with solid fuel cooking and discharge the air directly away from the mounting surface.



- Only spun steel fan in the industry.
- Withstands the most severe cleaning conditions.
- Most advanced motor cooling of any grease fan. Capable of continuously handling 400°F (204°C) airstream temperatures.
- UL/cUL 762 Listed for restaurant grease exhaust.
- Only kitchen-specific exhaust fan to meet Miami-Dade County Test protocols for Large Missile Impact Test.

Refer to page 17 for size chart.



Emergency Smoke Control - CUBE, USGF

When you buy a Greenheck model CUBE or USGF with the smoke control option, you receive a fan with the industry's best performance and durability for smoke control applications (as found in emergency smoke control systems).

Note: Model sizes CUBE-099, 161XP, 240XP, 300HP & 300XP are excluded for Emergency Smoke Control. Refer to page 17 for size chart.

- UL/cUL Listed for 500°F (260°C) for 4 hours and 1,000°F (538°C) for 15 minutes.
- Half the weight of traditional smoke control fans, ideal choice for roof load concerns.
- Low profile, height is less than half of traditional smoke control fans, maximum of 48 1/8 inches (1334 mm) from curb cap to top of fan.
- Multiple applications, capable of exhausting general clean air and satisfying emergency smoke control regulations.

Seismic - CUE, CUBE, CW and CWB

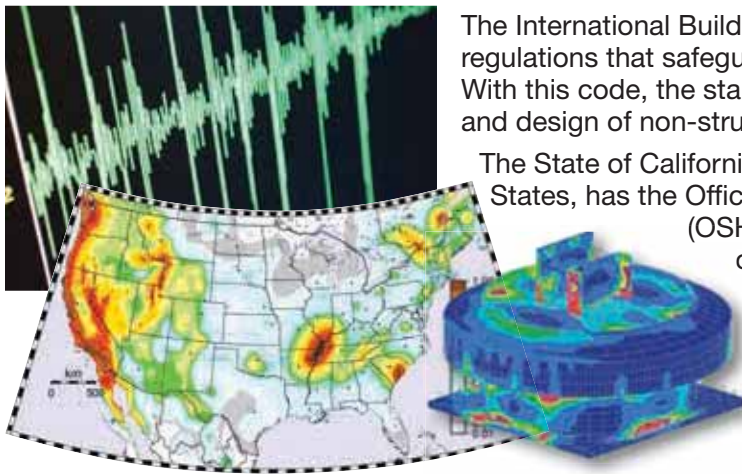

With changes in building codes and standards more equipment is being required to be seismically certified in areas of the country not commonly thought of as being in seismically active zones.

The International Building Code (IBC) is designed to provide model code regulations that safeguard public health and safety in all U.S. communities. With this code, the standards are intended to improve the performance and design of non-structural systems subject to seismic events.

The State of California, one of the most active seismic areas in the United States, has the Office of Statewide Health Planning and Development (OSHPD). OSHPD regulates the design and construction of healthcare facilities to ensure they are safe and capable of providing services to the public after a seismic event. OSHPD developed their own unique certification process to incorporate the IBC and ASCE testing standards to ensure equipment remains operable after a seismic event.

Protocols designed for seismic standards:

Seismic Testing Criteria

All Greenheck seismically certified models have been tested using the most severe seismic event that is found on the Spectral Response Map per IBC Figures 1613.5 (1-2). Because our testing is performed under the worst case scenario, using the highest mapped seismic load, highest level occupancy category, worst case site class, and highest code mandated importance factor, it allows Greenheck seismically certified fans to be used anywhere in the United States under any conditions.

California OSHPD Test Protocols

The California Office of Statewide Health Planning and Development (OSHPD) requires all certified models be shake table tested in accordance with ICC ES AC-156, in which the fans are physically subjected to the same or greater forces than they will see during a seismic event. By subjecting Greenheck model CUE, CUBE, CW and CWB fans to this type of testing ensures the fans will operate without problems after a seismic event.

OSHPD Certification

The OSHPD certification numbers and supporting documents can be viewed on OSHPD's website and ensures that the fan has been subjected to and passed rigorous testing standards.



High Wind and Hurricane - CUE, CUBE, CW, CWB and USGF

Greenheck is leading the High Wind Standard for roof top fans and ventilators. Forceful winds are the cause of most hurricane damage. While forceful



Atlantic, Gulf and Pacific history of major hurricane tracks.

winds are not the only problem, wind-borne debris can also cause detrimental effects to objects and structures. High winds product extreme forces on buildings and structures. By analyzing calculations, computer simulations, actual testing, and other standards— Greenheck developed the High Wind Standard.

Protocols designed to protect against wind-borne debris and severe wind loads:

Structural Performance Load

A static load that is 1.5 times the design load (195 pounds per square foot pressure) is applied both positive and negative to simulate wind force loads in each direction. Structural Performance per Dade County Protocol TAS-202 (ASTM E-330).

Large Missile Impact Test

Large Missile Impact Testing is required when objects are located 30 feet or less from the ground. The test is per Dade County Protocol TAS-201. The test unit is impacted three times with a piece of lumber (2 in. x 4 in. x 6 ft.) weighing approximately nine pounds and traveling at 34 mph. This simulates wind-borne debris striking the fan.

Miami-Dade NOA Numbers

The certifications can be viewed on the Miami-Dade County website. Models CUE, CUBE, CW, CWB and USGF are the first upblast aluminum/steel fans in the industry that have received a Miami-Dade NOA for high wind (150 mph) and hurricane zones.

Texas Department of Insurance

The certifications can be viewed on the Texas Department of Insurance Windstorm website.

Certified Independent Third-Party Testing

Each of the Greenheck models have been subjected to extensive testing procedures. The CUE, CUBE, CW, CWB and USGF have been certified by an independent third-party to the ASTM E-330 Static Pressure Difference Standard, Florida Building Code Test Protocols TAS-202 Static Pressure Difference and TAS-201 Large Missile Impact. All tests are video taped for documentation of test method and results.

Large missile impact test on a model USGF fan.



Applications

Severe Duty Roof Curbs for High Wind and Hurricane

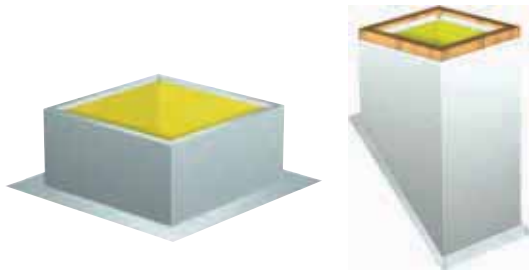

High wind and severe duty roof curbs are available on CUE, CUBE and USGF models with high wind certification. The severe duty roof curb models can ship separately to allow for final finishing of the roof prior to the fan arrival and installation.

Description	1 inch (25 mm) Insulation	Flashing Flange	Available Heights Inches (mm)
<p>GPF for flat roofs Curbs are used for high wind/seismic applications. Fully formed on three sides with a single, fully welded seam when dimension (L+Wx2) <118 inches (2,997 mm). Larger sizes are a fully welded assembly.</p>	✓	5 inches (127 mm)	8 to 42 (203 to 1067)
<p>GPFHL for heavy load applications Curb construction is intended to support compression loads exceeding 1,000 pounds (454 kg). GPFHL is mounted directly to the roof deck structure. The roofing material is brought to the vertical surface and sealed to the flashing flange. Additional standard construction features include 14-gauge galvanized steel and internal vertical support members.</p>	✓	5 inches (127 mm)	12 to 24 (305 to 610)
<p>GPFHD for supporting heavy load equipment For severe duty, high wind and seismic applications. The double thick flashing flange provides an extremely durable surface to secure the curb to the building structure. The roofing material is brought to the vertical surface and sealed to the flashing flange. Additional standard construction features include 12-gauge galvanized steel and internal vertical support members.</p>	✓	Double Thick 5 inches (127 mm)	12 to 24 (305 to 610)

Models CUE/CW



Greenheck's electronically commutated (EC) Vari-Green (VG) motor combines motor technology, controllability and energy-efficiency into one single low maintenance unit and is the industry's first fully controllable motor. When combined with Greenheck's CUE and CW fans, all the CFM and static pressure ranges of a belt drive can be attained with the benefits of a direct drive.

50/60 HZ Motor Information					
HP	RPM	Volts	Phase	FLA	Enclosure
1/10	1725	115	Single	1.5	TENV
1/6	1725	115/230	Single	3.1	TENV
1/4	1725	115/230	Single	3.9	ODP
1/2	1725	115/230	Single	6.2	ODP
1/2	2500	115/230	Single	6.5	ODP
3/4	1725	115/230	Single	10.1	ODP
3/4	2200	115/230	Single	11.3	ODP
1	1725	115/230	Single	12.4	ODP
1	1725	115/208-230	Single	12.0 / 6.0	TEFC
2	1725	208-230	Single	12.0	TEFC

Benefits

Operates on AC power that's converted to DC—providing a more efficient motor operation as compared to an AC operation.

- The motor can attain up to 85% efficiency and reduce energy consumption.
- Watt savings of 30-70% depending on RPM.
Note: As motor speed is turned down, efficiency stays high as compared to an AC motor which decreases dramatically.
- Operates cooler than a standard AC motor at lower RPMs. A cooler motor has longer motor life and reduces energy consumption.
- 80% usable RPM turndown versus 30%, see Motor Turndown Comparison chart at right.
- CUE and CW fans with Vari-Green motors can provide all the CFM and static pressure ranges of a comparable belt drive.
- Maintenance costs are reduced as there are no belts or bearings to replace and no pulleys to adjust.
- Direct drive fans are often preferred where maintenance access is difficult.
- Provides a solution for demand-controlled ventilation applications.

Vari-Green Advantages

- Initial cost is similar to a belt drive
- Lower operating cost
- No maintenance, no belts, pulleys or bearings
- Easy RPM adjustment

Features

1. **Dial on Motor Control** - a potentiometer (dial on motor control) is mounted on the motor for easy speed adjustment for system balance. Simply turn the dial. There are no belts and pulleys to adjust.
2. **Control Wire Inputs** - the motor accepts a 0-10V DC signal from Building Automated Systems or other controls to adjust motor speed.



Comparisons: Belt, Direct Drive with PSC and Direct Drive with Vari-Green

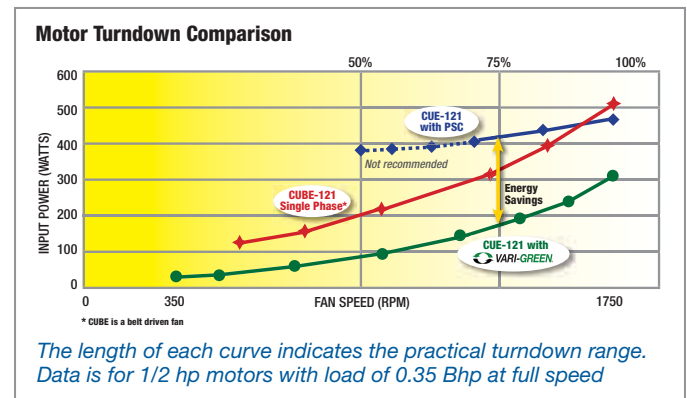

Constant Volume Life Cycle Analysis

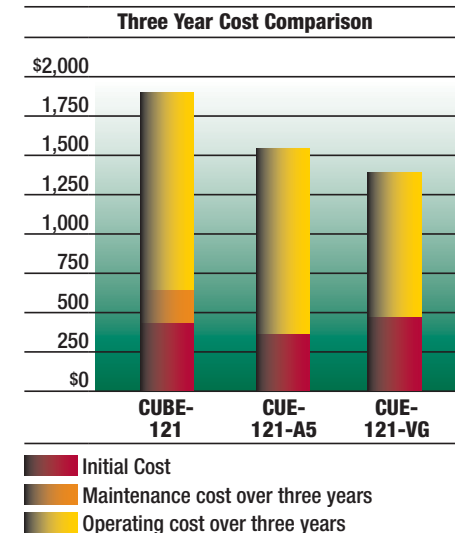

Analysis is based on operating costs for a period of three years where the fans operate continuously at 1725 rpm, 24/7, with an energy rate of \$0.10/kWh. Maintenance on the CUBE-121 is estimated at \$65/yr. Note: Example is based on a relative cost. Use and installation variables may produce different results.

Demand Control Ventilation for Multistory Buildings



Applications requiring constant pressure or variable volume can utilize CUE or CW fans with Vari-Green motors and Vari-Green controls. Demand control ventilation systems reduce the amount of energy used by decreasing the speed of the fan when demand is low. This in turn lessens the amount of conditioned air exhausted and further reduces total operating costs associated with air conditioning and heating in multistoried buildings such as hotels, multifamily complexes, institutional facilities, and high rise commercial buildings.

Variable Volume Operating Cost Analysis

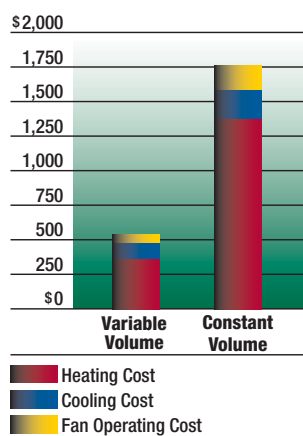

Example of potential savings based on a northeast city in the USA using Vari-Green components for Variable Volume.

The Vari-Green constant pressure control is preprogrammed and easy to install for applications that include venting dryers, bathrooms, residential type kitchen space or industrial process exhaust.

Contact fans@greenheck.com for more information.

Daily Operating Comparison: Variable Volume and Constant Volume

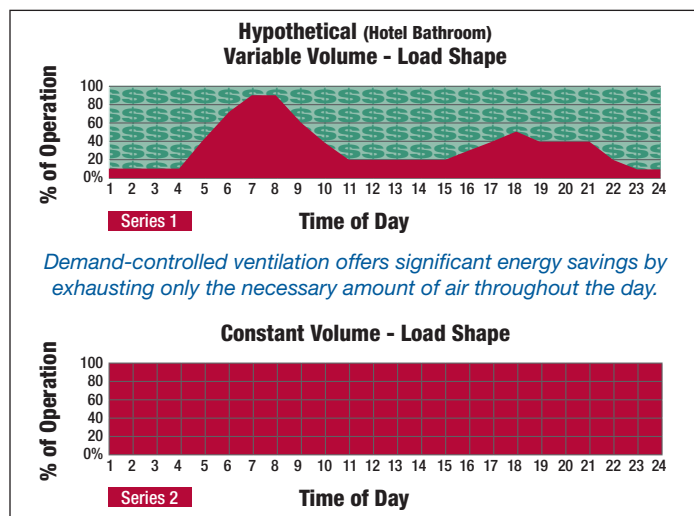

Demand-controlled ventilation offers significant energy savings by exhausting only the necessary amount of air throughout the day.

Note: A standard VFD compatible motor can also function within a Variable Volume system.

Vari-Green® Controls

Transformer - Provides 24V power from the existing line voltage at the fan to the Vari-Green motor and controls. Dual voltage primary (120/240V) transformer provided with the fan.

Remote Dial - Allows for remote, manual airflow adjustments. Wall plate with dial may be mounted in a standard 2x4 inch electrical junction box.

Two Speed Control with Integral Transformer Control allows motor rpm to be set at two independent speeds (high or low). Meets minimum airflow requirements with the ability to bump up to high speed in an emergency or meet maximum airflow requirements, or reset down to low for energy conservation.

Constant Pressure Control – Indoor - Control Vari-Green motor via static (variable volume) or velocity (constant CFM) pressure on the inlet or outlet side of the fan. Optional, one or two, duct or room probes for use in:

- Multifamily structures - Apartments, condos, hotels; dryers, residential kitchens and bathrooms.
- Institutional facilities - Schools, prisons, multistory office buildings; bathrooms.

Constant Pressure Control – Outdoor - Control a Vari-Green motor via static pressure on the inlet side of the fan. Includes one duct probe and transducer for use in:

- Multifamily structures - Apartments, condos, hotels; residential kitchen, dryer facilities and bathrooms.
- Institutional facilities - Schools, prisons, multistory.

Air Quality – VOC - Control a Vari-Green motor via changes in volatile organic compounds (VOC's). VOC's are gasses that are emitted from humans, building materials, perfumes, foods, and furniture off-gassing. Range is 0-2000 CO₂ PPM equivalent.

- Institutional facilities – Schools, court houses, hospitals; bathrooms, waiting rooms, cafeterias.
- Commercial buildings – Office spaces, conference rooms, bathrooms, break rooms.

Air Quality – Temperature and Humidity - Control Vari-Green motor via changes in temperature, humidity, or both. Range is 32 to 120°F and 0 to 100% relative humidity.

- Multifamily structures - Apartments, condos, hotels; bathrooms, utility rooms.
- Commercial buildings - Office buildings, office space, conference rooms, utility rooms, bathrooms.



Greenheck's Vari-Green Drive is a factory mounted, wired, and programmed variable frequency drive. Specifically designed for use in air handling applications, the Vari-Green drive expands variable volume operation and simplistic speed adjustment to three phase applications.

Features

The Vari-Green Drive is available in two models, VGD-100 and VGD-100+. Both of these models are constructed with a NEMA-4X rated enclosure to ensure a long life operating under outdoor environmental conditions. Every Vari-Green Drive is compatible with all Vari-Green controls or any industry control sending a 0-10V signal; model VGD-100+ is also equipped with Modbus/BACnet communications allowing for seamless integration to building management systems.

	VGD-100	VGD-100+
Analog Input (0-10V, 4-20mA)	✓	✓
Damper Actuator Output (24VDC)	✓	✓
Control Voltage Output (24VDC)	✓	✓
LED Indication Lights (3)	✓	✓
Relay Output (2)		✓
Digital Input - Dry (2)		✓
Digital Input - Voltage (2)		✓
RS-485 (Modbus/BACnet)		✓
Bluetooth/Smart Device Interface		✓
On-Board PID Control		✓
Optional Pressure Transducer		✓

Benefits

- Variable volume control from the factory on larger fan sizes where Vari-Green motors are not available.
- R³ filtering and short leads mitigates harmonics.
- Quick start-up and simplistic commissioning as each drive comes pre-programmed and installed from the factory.
- Eliminate compatibility issues as the motor and drive are factory matched.
- Induction motors are reliable, efficient and readily available if replacements are needed.

Vari-Green® Drive App



The Vari-Green Drive model VGD-100+ features a smart phone companion app available for download from the app store. Manually control and monitor the drive from the app as well as access any advanced programming features. For more information about the companion app and its capabilities, reference the VGD-100+ Quick Start Guide located on greenheck.com and the documentation section of the app.



Options and Accessories

The following chart shows which options and accessories are available on Greenheck's roof upblast and sidewall exhaust fans.

Options and Accessories	CUE	CUBE	CW	CWB	USGF
Sidewall Mount	✓	✓	std.	std.	
Roof Curbs	✓	✓			✓
Curb Extensions	✓	✓			✓
Curb Seal	✓	✓			std.
Windband Extension	✓	✓			✓
Hinged Curb Cap	✓	✓			
Hinged Base	✓	✓			std.
Tie-Down Points	✓	✓			✓
Drain Connection	✓	✓			✓
Grease Trap	✓	✓			✓
Grease Trap with Absorbent Material	✓	✓			✓
Clean-Out Port	✓	✓			std.
Birdscreen	✓	✓	std.	std.	
Non-Stick Wheel	✓	✓	✓	✓	std.
Disconnect Switches	✓	✓	✓	✓	✓
Dampers	✓	✓	✓	✓	
Speed Controllers	✓		✓		
Motor Starters	✓	✓	✓	✓	✓
UL 705	✓	✓	✓	✓	
UL 762	✓	✓	✓	✓	std.
UL Emergency Smoke Control Systems		✓			✓
Coatings	✓	✓	✓	✓	✓

Sidewall Mount — Allows for a horizontal discharge with a square mounting base, models CUE and CUBE.

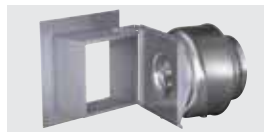

Roof Curbs — Wide variety of roof curbs are available for mounting the fan to the roof, including: vented, flanged, pitched and sound-absorbing. For more information on severe duty curbs refer to the information on page 9.

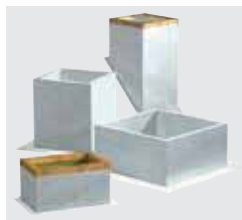

Curb Extensions — Mounts between roof curb and fan for additional height from roof top.

Vented Curb Extensions — Mounts between roof curb and roof mounted fan to meet NFPA requirements of 40-inch (1016 mm) minimum discharge above the roof when mounted on a minimum 8-inch (203 mm) high roof curb.



Curb Seal — Foam or high temperature seal between fan and curb to assure proper sealing when attached to a curb.

Windband Extension — Aluminum tube raising the fan discharge height.

Hinged Curb Cap Kit — The hinged curb cap allows the entire fan to swing open to allow maintenance personnel access to the wheel and ductwork for regular inspection and cleaning. Hinged curb cap kit is an option on all upblast models.



Hinged Base — Available on sizes up to 480, allows for easy maintenance. Hinge and restraining cables are factory-mounted to a sub-base attached directly to curb without additional height added. Mounted hinged base with cables standard on all USGF fans.



Tie-Down Points — Four brackets located on the windband for securing the fan in heavy wind applications.



Drain Connection — Allows for single-point drainage of grease, water or other residues.



Grease Trap — Polypropylene trap designed to collect grease residue to avoid drainage onto roof surface.



Grease Trap with Absorbent Material — Same as above with an absorbent material to collect grease residue for easy disposal.

Options and Accessories

Clean-Out Port — Patented removable plug allows for easy spray or steam cleaning of wheel through the windband. Available on select models.



Birdscreen — Galvanized or aluminum rigid wire to protect the fan discharge from birds or small objects. Galvanized is standard on CW and CWB models.

Non-Stick Aluminum Wheel — Patented coating helps prevent wheel imbalance in heavy grease applications and allows buildup on wheel to be easily removed.



Disconnect Switches — Assorted NEMA rated switches are available for positive electrical shutoff and safety, including: dust-tight, rainproof and corrosion-resistant.



Dampers — Designed to prevent outside air from entering back into the building when fan is off. Includes backdraft and motorized dampers. (Not available with UL/cUL 762 or USGF fans).



Speed Controllers — Available for use with shaded pole and permanent split capacitor open motors on direct drive fans. They provide an economical means of system balancing.



Motor Starters — The fundamental function of a motor starter is to protect the motor from damage that can occur from overheating. With a Greenheck motor starter you will be provided with the best motor protection available.



Specific model components may include: SmartStart™ technology, physical interface, overload protection, disconnect, magnetic contactor, NEMA-1 or NEMA-3R steel enclosures and pre-engineered easy system integration. For complete information on specific Greenheck Motor Starter models refer to greenheck.com, Motor Starters webpage.

UL/cUL 705 — Models CUE, CUBE, CW and CWB, may be UL Listed for Electrical. CUBE for Smoke Control comes standard with UL 705.

UL/cUL 762 — Models CUBE, CWB and CUE and CW sizes 099 and larger, may be Listed for Grease Removal. Model USGF comes standard with UL 762.

UL/cUL Emergency Smoke Control — Models CUBE and USGF may be Listed for Emergency Smoke Control.

Note: Model sizes CUBE-099, 161XP, 240XP, 300HP & 300XP are excluded from Emergency Smoke Control.

Coatings — Wide variety of coatings and colors are available for decorative to protective applications.



Primer is applied at the factory to allow for final finish in the field. Not available on model USGF.



Permatector™ is our standard coating on steel fans and is typically used for applications that require corrosion resistance in indoor and outdoor environments.



Hi-Pro Polyester is resistant to salt water, chemical fumes and moisture in more corrosive atmospheres. Typically used for applications that require superior chemical resistance, excellent abrasion and outdoor UV protection. This coating exceeds protective qualities of Air Dried Heresite and Air Dry Phenolic. Customers can choose from seven standard decorative colors or color match any color.



Baked Enamel Decorative Coatings are heat cured enamels applied as electrostatic powders. Customers can choose from seven standard decorative colors or color match any color.

Note: Colors are subject to change. See Performance Coatings for Commercial & Industrial Fans catalog for more details.

General Clean Air/Fume Hood (Non Grease)

All CUE, CUBE, CW and CWB exhaust fans are designed for applications ranging from clean air to contaminated air. A typical installation is shown.

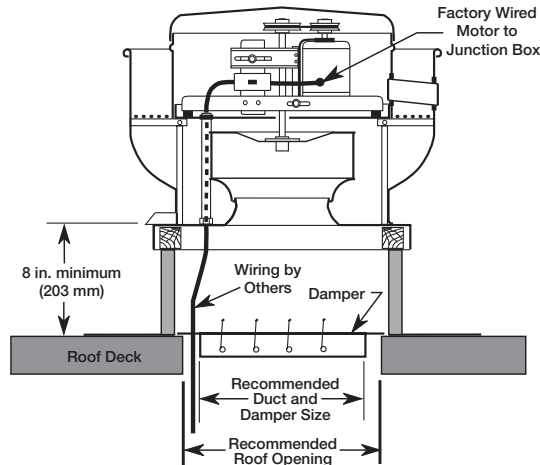

Models CUE and CUBE

When roofing materials extend to the top of the curb, roof curbs should be 1½-inches (¾-inch on a side) less than the unit curb cap to allow for roofing and flashing.

- For recommended duct size, damper size and roof opening dimensions, refer to the performance data pages.
- Installation must include a means for inspecting, cleaning and servicing the exhaust fan.

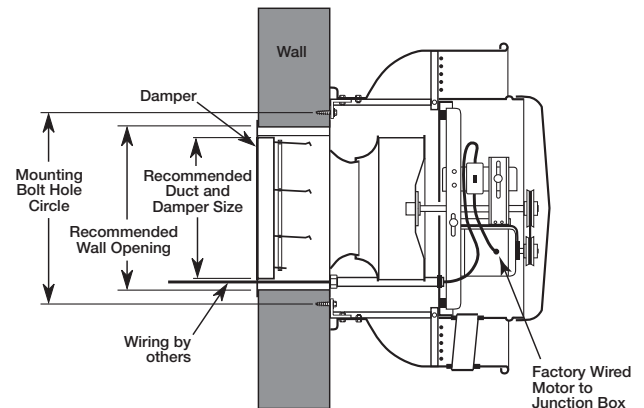

Models CW and CWB

Emergency Smoke Control

The CUBE with smoke option and the USGF are specifically designed for Emergency Smoke Control applications. These fans are UL/cUL Listed for Electrical and Power Ventilators for Smoke Control Systems for 500°F (260°C) for 4 hours and 1,000°F (538°C) for 15 minutes.

- Due to the varying airstreams encountered in commercial ventilation, system designers must be aware of national, state, and local codes and guidelines governing these installations. Local code authorities should be consulted before proceeding with any ventilation project.
- When roofing materials extend to the top of the curb, roof curbs should be 1½-inches (¾-inch on a side) less than the unit curb cap to allow for roofing and flashing.
- For recommended duct size, damper size and roof opening dimensions, refer to the performance data pages.

- Installation must include a means for inspecting, cleaning and servicing the exhaust fan.
- Exhaust fans used in emergency smoke applications must have external wiring. (Wiring must not be installed in the airstream).

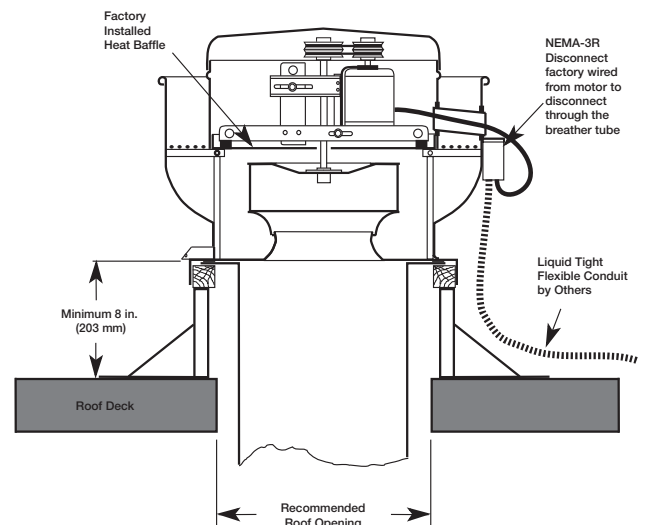

Models CUBE and USGF

Commercial Kitchen (Grease)

Models CUBE, CWB, USGF and models CUE and CW sizes 099 and larger, are designed to meet restaurant and food service applications. These fans are UL/cUL Listed for Grease Removal and have been tested under high temperature [400°F (204°C)] and abnormal flare-up [600°F (316°C)] conditions.

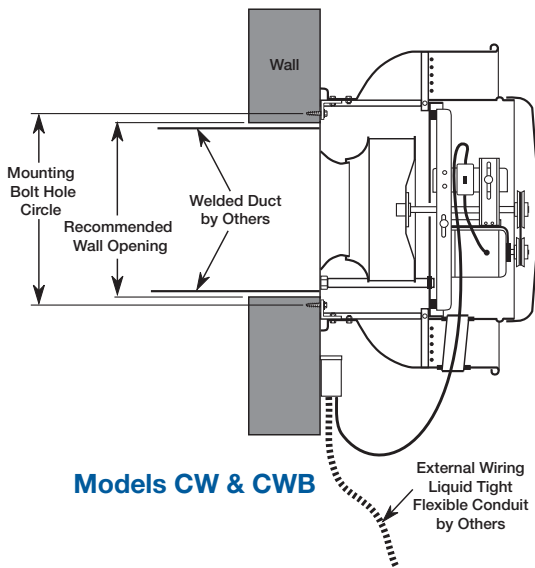

- Due to high temperatures and grease-laden airstreams in commercial kitchen ventilation, system designers must be aware of governing codes and guidelines. The National Fire Protection Association (NFPA) is the primary source which governs many codes for commercial kitchen ventilation. Selected information from NFPA 96 is shown below. Local code authorities should be consulted before proceeding with any kitchen ventilation project.
- Exhaust fans used in kitchen ventilation applications must have external wiring. (Wiring must not be installed in the airstream).
- Installation must include a means for inspecting, cleaning and servicing the exhaust fan. Greenheck offers a Hinged Curb Cap option for upblast exhaust fans. The Hinged Base is standard on model USGF.
- No dampers are to be installed in the system.

Note:

- The typical installations shown on these two pages are recommendations based on national codes. Local authority may supersede these recommendations.
- Drawing shows NEMA-1 Standard, NEMA-3R is optional.

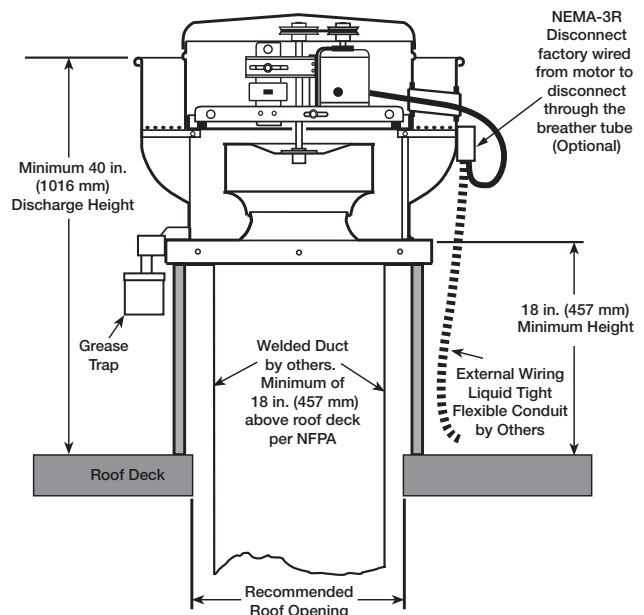
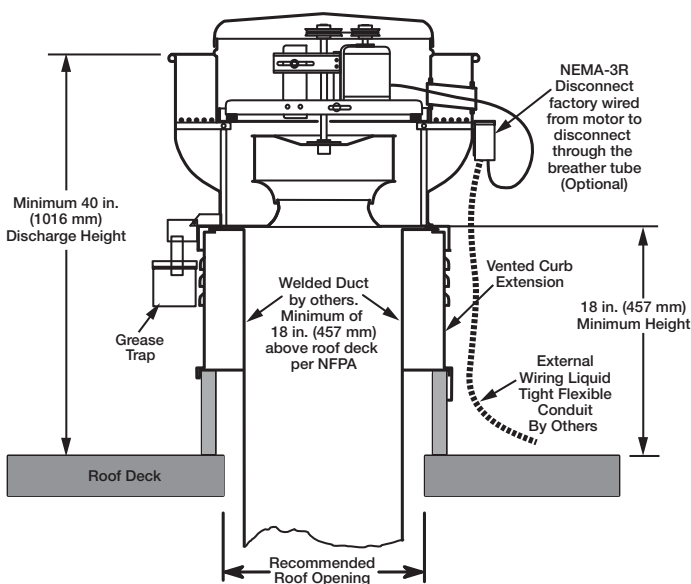

Performance & Dimensions Quick Reference					Material Thickness		
Page Index					Windband	Motor Cover	Curb Caps
Model Size	CUBE CWB	CUE CW	CUBE Smoke Option	USGF			
060		18 •			0.051 (1.3)	0.051 (1.3)	0.051 (1.3)
070		19 •					
080		20 •			0.051 (1.3)	0.051 (1.3)	0.064 (1.6)
090		21 •					
095		22 •					
099	23 •						
101	24 •		x				
101HP	25 •		x				
121	26 •		x				
131	27 •		x				
140	28			x			
141	28 •		x			0.040 (1.0)	0.064 (1.6)
140HP	29			x			
141HP	29 •		x				
160	30			x			
161	30 •		x				
160HP	31			x			
161HP	31 •		x				
160XP	32			x			
161XP	32						
180	33 •		x	x			
180HP	34		x	x			
200	35		x	x	0.064 (1.6)		
200HP	36	CUE only 36	x	x	USGF 0.051 (1.3)	0.040 (1.0)	0.064 (1.6)
220	37		x				
220HP	38		x				
240	39	CUE only 39	x				
240HP	40	CUE only 40	x		0.064 (1.6)	0.051 (1.3)	0.064 (1.6)
240XP	41						
300	42	CUE only 42	x				
300HP	43	CUE only 43			0.080 (2.0)	0.051 (1.3)	0.064 (1.6)
CUBE only							
300XP	44						
360	45		x				
360HP	46		x		0.080 (2.0)	0.064 (1.6)	0.080 (2.0)
360XP	47						
420	48		x				
480	49		x		0.080 (2.0)	0.064 (1.6)	0.100 (2.5)

The Model number system is designed to completely identify the fan. The correct code letters must be specified to designate belt or direct drive. The remainder of the model number is determined by the size and performance.

CUBE - 240 HP - VG/5/A X

Fan Size

060 through 480

Wheel Pressure Level

HP - High-Pressure

XP - Extended High-Pressure
(Belt Drive Only)

Configuration

CUE - Belt Drive Roof or Wall Mounted

CUBE - Direct Drive Roof or Wall Mounted

CW - Belt Drive Wall Mounted

CW - Direct Drive Wall Mounted

USGF - Belt Drive Roof Mounted

VG = Vari-Green®

(Direct Drive Only)

Motor HP (Belt Drive Only)

4 = 1/4 10 = 1 30 = 3
 3 = 1/3 15 = 1½ 50 = 5
 5 = 1/2 20 = 2 75 = 7½
 7 = 3/4

60 HZ Motor RPM (Direct Drive Only)

A = 1725 D = 1550
 B = 1140 E = 1050
 C = 860 G = 1300

50 HZ Motor RPM (Direct Drive Only)

International (See CAPS for performance)

K = 950 RPM J = 1425 RPM
 L = 1290 RPM

X = UL 705

F = UL Smoke Control Systems

G = UL 762

• Vari-Green option available on direct drive models

Roof Upblast/Sidewall Exhaust Size-060: CUE • CW

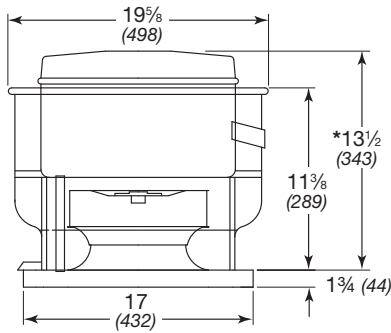

Direct Drive RPM

E-1050 RPM
G-1300 RPM
D-1550 RPM
VG-1725 RPM

CUE
CW

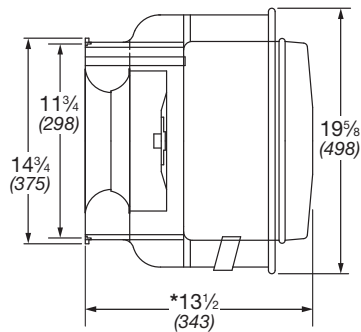

All dimensions in inches (millimeters), weight in pounds (kilograms).
 * May be greater depending on motor.
 ^Weight shown is largest cataloged open drip-proof motor.
 Specifications and image for each model located at back of catalog.

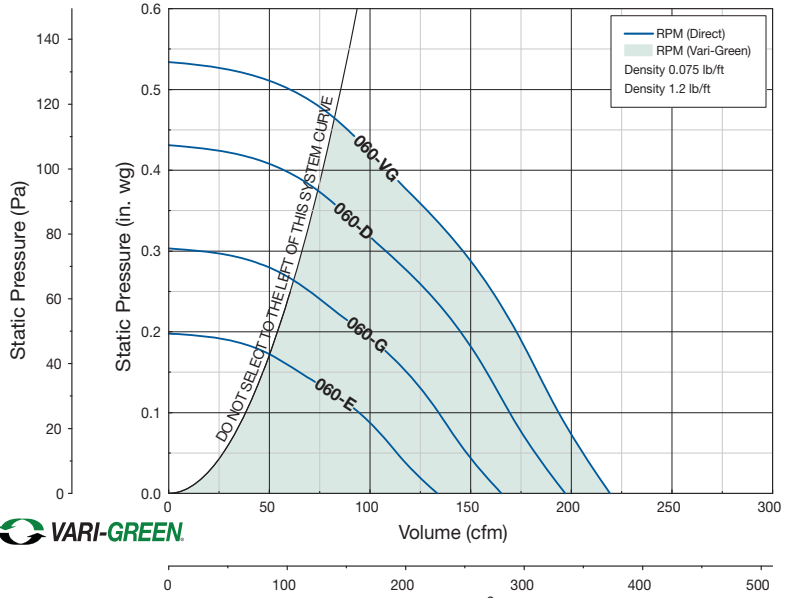

	CUE	CW
^Approximate Weight	29 (13)	26 (12)
Damper Size	8 x 8 (203 x 203)	8 x 8 (203 x 203)
Roof/Wall Opening	10 1/2 x 10 1/2 (267 x 267)	8 1/2 x 8 1/2 (216 X 216)

Motor HP	Fan RPM	Direct	Static Pressure in Inches wg											
			0	0.05	0.1	0.125	0.15	0.2	0.25	0.3	0.35	0.375		
060														
VARI-GREEN VG-1/10	E-1/200	1050	CFM	133	113	94	81	65						
			BHP	0.01	0.01	0.01	0.01	0.01						
			Sones	1.7	1.7	1.7	1.7	1.7						
	G-1/100	1300	CFM	165	148	134	126	117	96	70				
			BHP	0.01	0.01	0.01	0.01	0.01	0.01	0.01				
			Sones	2.9	2.6	2.5	2.5	2.5	2.5	2.5				
	D-1/60	1550	CFM	197	183	169	164	158	143	128	107	85		
			BHP	0.02	0.02	0.02	0.02	0.02	0.02	0.02	0.02	0.02	0.02	
			Sones	4.3	3.9	3.9	3.9	3.9	4.0	4.0	4.0	4.0	4.0	
		1725	CFM	219	207	194	188	183	172	159	146	137	118	
			BHP	0.028	0.028	0.028	0.028	0.028	0.028	0.028	0.028	0.029	0.029	0.029
			Sones	5.4	5	5.1	5.2	5.2	5.2	5.3	5.3	5.4	5.5	

Performance certified is for installation type A: Free inlet, Free outlet. Power rating (Bhp) does not include transmission losses. Performance ratings do not include the effects of appurtenances (accessories). The sound ratings shown are loudness values in fan sones at 5 ft. (1.5 m) in a hemispherical free field calculated per AMCA Standard 301. Values shown are for installation type A: Free inlet hemispherical sone levels.

Roof Upblast/Sidewall Exhaust

Size-070: CUE • CW

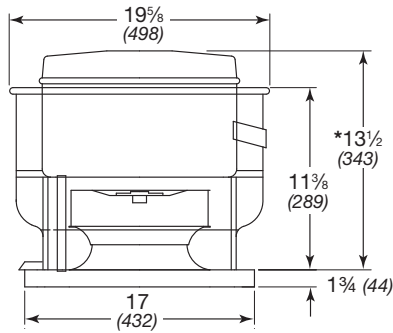

Direct Drive RPM

E-1050 RPM
G-1300 RPM
D-1550 RPM
VG-1725 RPM

CUE
CW

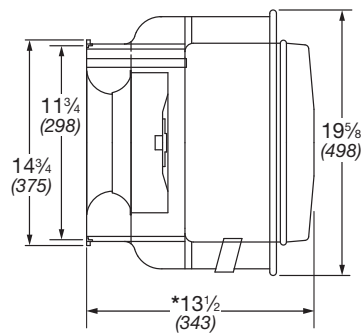

All dimensions in inches (millimeters), weight in pounds (kilograms).
 * May be greater depending on motor.
 ^Weight shown is largest cataloged open drip-proof motor.
 Specifications and image for each model located at back of catalog.

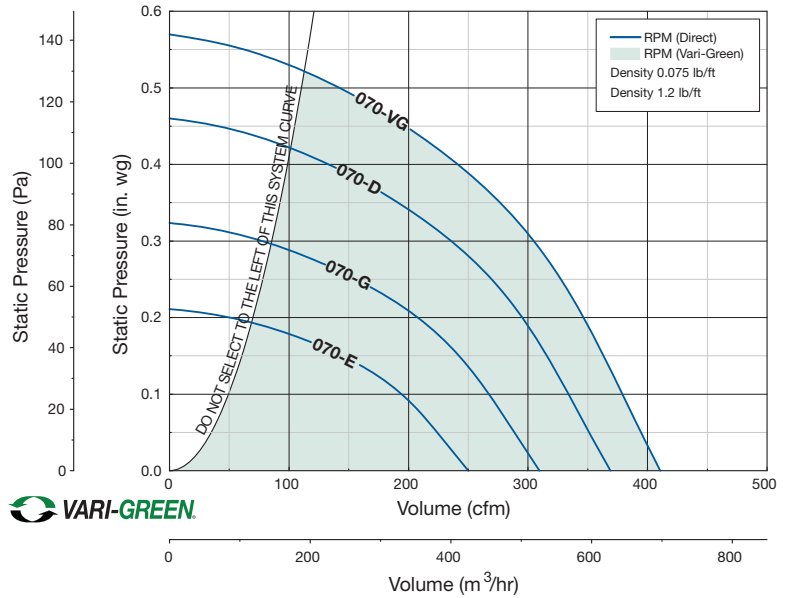

	CUE	CW
^Approximate Weight	29 (13)	26 (12)
Damper Size	8 x 8 (203 x 203)	8 x 8 (203 x 203)
Roof/Wall Opening	10 1/2 x 10 1/2 (267 x 267)	8 1/2 x 8 1/2 (216 X 216)

Motor HP	Fan RPM		Static Pressure in Inches wg										
			0	0.05	0.1	0.125	0.15	0.2	0.25	0.3	0.35	0.375	
070													
VARI-GREEN	E-1/100	1050	CFM	250	224	193	171	143					
			BHP	0.01	0.01	0.01	0.01	0.01					
			Sones	2.7	2.1	1.7	1.4	1.1					
	G-1/60	1300	CFM	309	288	267	255	241	205	152			
			BHP	0.01	0.01	0.02	0.02	0.02	0.02	0.01			
			Sones	4.1	3.8	3.4	3.3	3.2	2.8	2.5			
	D-1/30	1550	CFM	369	351	333	325	316	293	269	234	187	160
			BHP	0.02	0.02	0.03	0.03	0.03	0.03	0.03	0.03	0.03	0.02
			Sones	5.6	5.4	5.2	5.2	5.1	4.9	4.7	4.5	4.1	3.9
		1725	CFM	411	395	379	371	363	346	326	305	289	258
			BHP	0.032	0.032	0.033	0.034	0.035	0.036	0.036	0.036	0.036	0.035
			Sones	6.8	6.7	6.7	6.6	6.6	6.5	6.4	6.2	6.1	5.9

Performance certified is for installation type A: Free inlet, Free outlet. Power rating (Bhp) does not include transmission losses. Performance ratings do not include the effects of appurtenances (accessories). The sound ratings shown are loudness values in fan sones at 5 ft. (1.5 m) in a hemispherical free field calculated per AMCA Standard 301. Values shown are for installation type A: Free inlet hemispherical sone levels.

Roof Upblast/Sidewall Exhaust Size-080: CUE • CW

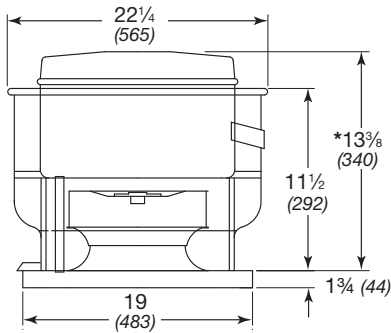

Direct Drive RPM

E-1050 RPM
G-1300 RPM
D-1550 RPM
VG-1725 RPM

CUE
CW

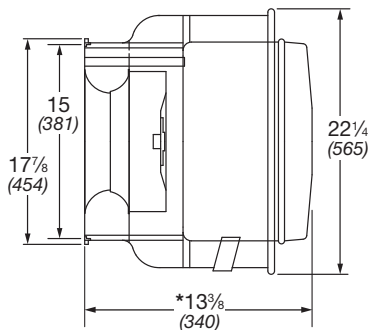

All dimensions in inches (millimeters), weight in pounds (kilograms).
 * May be greater depending on motor.
 ^Weight shown is largest cataloged open drip-proof motor.
 Specifications and image for each model located at back of catalog.

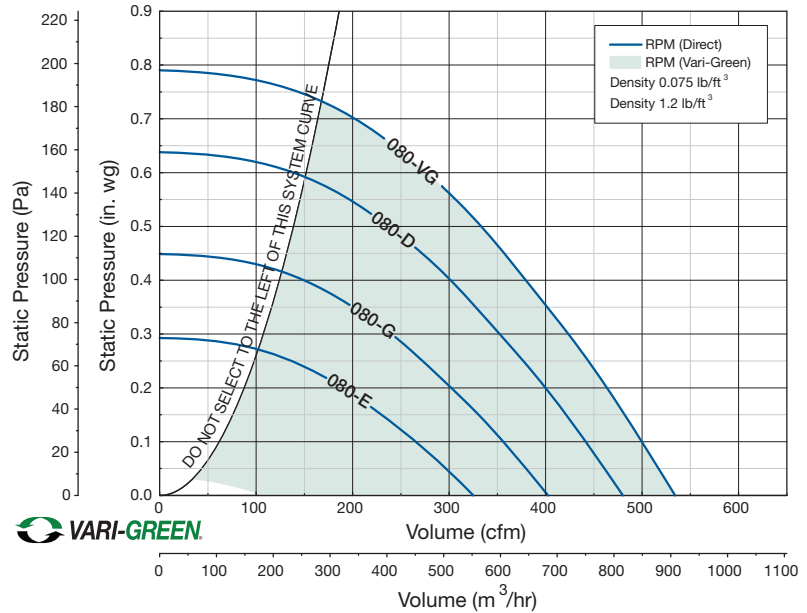

	CUE	CW
^Approximate Weight	40 (18)	40 (18)
Damper Size	10 x 10 (254 x 254)	10 x 10 (254 x 254)
Roof/Wall Opening	12½ x 12½ (318 x 318)	10½ x 10½ (267 X 267)

Motor HP	Fan RPM	Static Pressure in Inches wg											
		0	0.1	0.125	0.15	0.2	0.25	0.3	0.375	0.5	0.625		
080													
VARI-GREEN VG-1/10	E-1/40	1050	CFM	325	265	247	230	189	133				
		BHP	0.01	0.01	0.02	0.02	0.02	0.02	0.02				
		Sones	3.8	3.7	3.6	3.7	3.9	4.2					
	G-1/30	1300	CFM	403	356	343	330	302	272	239	173		
		BHP	0.02	0.03	0.03	0.03	0.03	0.03	0.03	0.03	0.03		
		Sones	5.4	5.4	5.4	5.4	5.4	5.5	5.6	5.9			
	D-1/20	1550	CFM	480	441	431	421	400	376	352	314	235	
		BHP	0.04	0.04	0.04	0.04	0.05	0.05	0.05	0.05	0.05	0.05	
		Sones	7.3	7.3	7.3	7.3	7.3	7.2	7.2	7.2	7.3	7.5	
		1725	CFM	534	500	491	481	463	444	423	390	333	257
		BHP	0.05	0.06	0.06	0.06	0.06	0.06	0.06	0.07	0.07	0.07	0.07
		Sones	8.4	8.5	8.5	8.5	8.6	8.6	8.6	8.6	8.5	8.7	8.7

Performance certified is for installation type A: Free inlet, Free outlet. Power rating (Bhp) does not include transmission losses. Performance ratings do not include the effects of appurtenances (accessories). The sound ratings shown are loudness values in fan sones at 5 ft. (1.5 m) in a hemispherical free field calculated per AMCA Standard 301. Values shown are for installation type A: Free inlet hemispherical sone levels.

Roof Upblast/Sidewall Exhaust

Size-090: CUE • CW

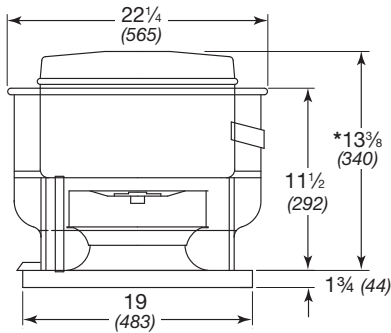

Direct Drive RPM

E-1050 RPM
G-1300 RPM
D-1550 RPM
VG-1725 RPM

CUE
CW

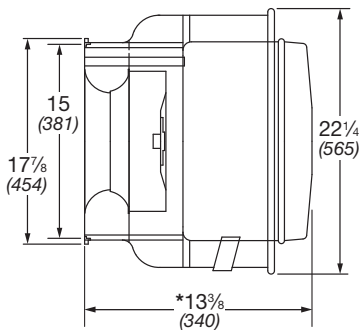

All dimensions in inches (millimeters), weight in pounds (kilograms).
 * May be greater depending on motor.
 ^Weight shown is largest cataloged open drip-proof motor.
 Specifications and image for each model located at back of catalog.

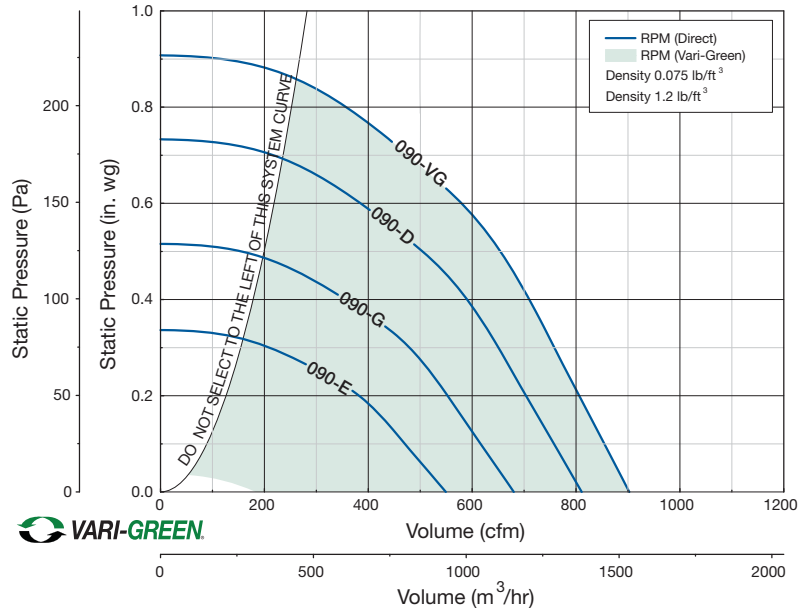

	CUE	CW
^Approximate Weight	40 (18)	40 (18)
Damper Size	10 x 10 (254 x 254)	10 x 10 (254 x 254)
Roof/Wall Opening	12½ x 12½ (318 x 318)	10½ x 10½ (267 X 267)

Motor HP	Fan RPM		Static Pressure in Inches wg											
			0	0.1	0.125	0.15	0.2	0.25	0.3	0.375	0.5	0.625		
090														
VARI-GREEN	E-1/40	1050	CFM	549	470	451	429	381	306	204				
			BHP	0.02	0.02	0.02	0.03	0.03	0.03	0.03				
			Sones	4.0	3.9	3.9	4.0	4.1	4.2	4.5				
	G-1/30	1300	CFM	680	616	600	584	553	517	479	391			
			BHP	0.04	0.04	0.04	0.04	0.05	0.05	0.05	0.05			
			Sones	5.4	5.4	5.4	5.4	5.4	5.5	5.5	5.6			
	D-1/20	1550	CFM	811	757	744	731	704	677	651	604	501	347	
			BHP	0.06	0.07	0.07	0.07	0.07	0.08	0.08	0.08	0.08	0.09	0.08
			Sones	7.6	7.5	7.5	7.5	7.5	7.5	7.4	7.4	7.4	7.4	7.9
		1725	CFM	903	854	842	830	806	782	758	722	652	553	
			BHP	0.08	0.09	0.09	0.09	0.1	0.1	0.1	0.11	0.12	0.12	
			Sones	8.8	8.8	8.8	8.8	8.8	8.8	8.7	8.7	8.8	8.9	

Performance certified is for installation type A: Free inlet, Free outlet. Power rating (Bhp) does not include transmission losses. Performance ratings do not include the effects of appurtenances (accessories). The sound ratings shown are loudness values in fan sones at 5 ft. (1.5 m) in a hemispherical free field calculated per AMCA Standard 301. Values shown are for installation type A: Free inlet hemispherical sone levels.

Roof Upblast/Sidewall Exhaust

Size-095: CUE • CW

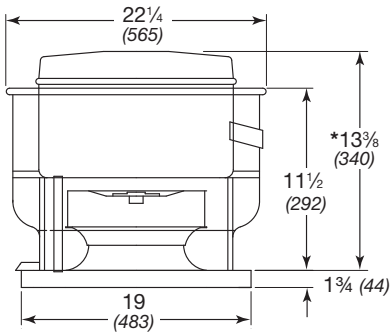

Direct Drive RPM

E-1050 RPM
G-1300 RPM
D-1550 RPM
VG-1725 RPM

CUE
CW

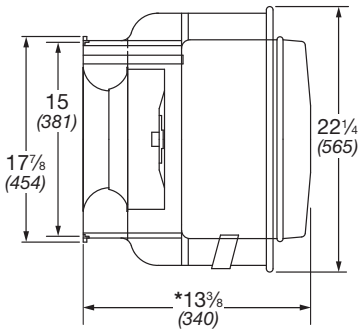

All dimensions in inches (millimeters), weight in pounds (kilograms).
 * May be greater depending on motor.
 ^Weight shown is largest cataloged open drip-proof motor.
 Specifications and image for each model located at back of catalog.

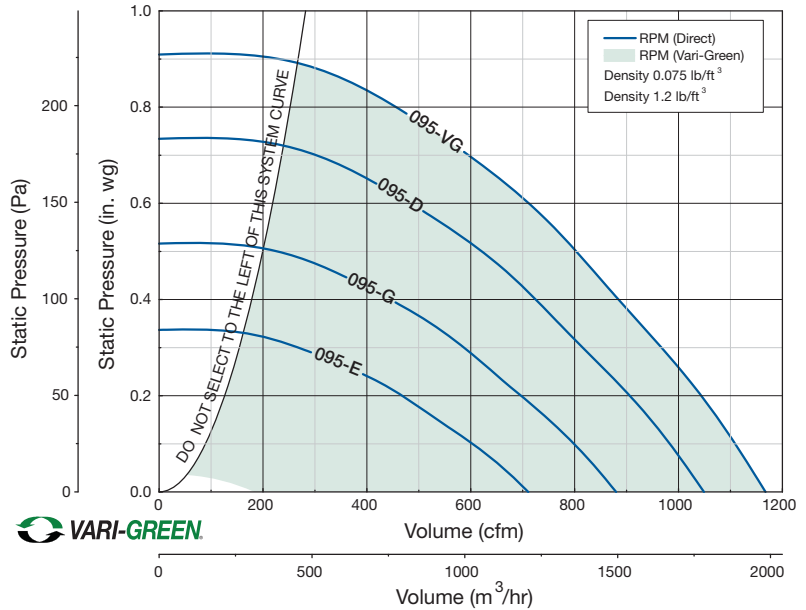

	CUE	CW
^Approximate Weight	40 (18)	40 (18)
Damper Size	10 x 10 (254 x 254)	10 x 10 (254 x 254)
Roof/Wall Opening	12½ x 12½ (318 x 318)	10½ x 10½ (267 X 267)

Motor HP	Fan RPM	Static Pressure in Inches wg	Static Pressure in Inches wg									
			0	0.1	0.125	0.15	0.2	0.25	0.3	0.375	0.5	0.625
095												
VARI-GREEN VG-1/6	E-1/30	1050	CFM 711	603	570	536	468	381	265			
		BHP 0.03	0.04	0.04	0.04	0.04	0.04	0.04	0.03			
		Sones 5.4	4.5	4.5	4.5	4.4	4.5	4.6				
	G-1/12	1300	CFM 880	797	774	750	696	641	587	484	199	
		BHP 0.06	0.07	0.07	0.07	0.07	0.07	0.07	0.07	0.07	0.05	
		Sones 7.6	6.9	6.7	6.6	6.5	6.4	6.4	6.4	6.4	6.8	
	D-1/8	1550	CFM 1049	983	964	944	905	861	816	747	616	442
		BHP 0.1	0.11	0.11	0.11	0.11	0.11	0.12	0.12	0.12	0.12	0.11
		Sones 9.6	9.4	9.3	9.2	8.9	8.6	8.4	8.3	8.3	8.1	7.8
	1725	CFM 1167	1108	1093	1077	1041	1005	967	905	802	680	
		BHP 0.14	0.15	0.15	0.15	0.16	0.16	0.16	0.17	0.17	0.17	
		Sones 11.3	11.1	11.0	11.0	10.8	10.5	10.2	9.9	9.8	9.6	

Performance certified is for installation type A: Free inlet, Free outlet. Power rating (Bhp) does not include transmission losses. Performance ratings do not include the effects of appurtenances (accessories). The sound ratings shown are loudness values in fan sones at 5 ft. (1.5 m) in a hemispherical free field calculated per AMCA Standard 301. Values shown are for installation type A: Free inlet hemispherical sone levels.

Roof Upblast/Sidewall Exhaust

Size-099: CUBE • CUE • CWB • CW

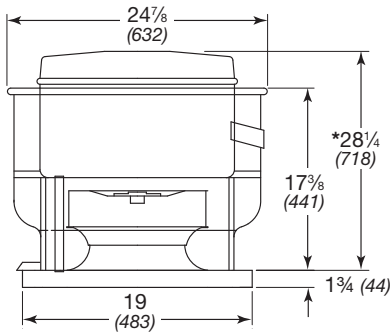

Direct Drive RPM

C-860 RPM
B-1140 RPM
A-1725 RPM
VG-1725 RPM

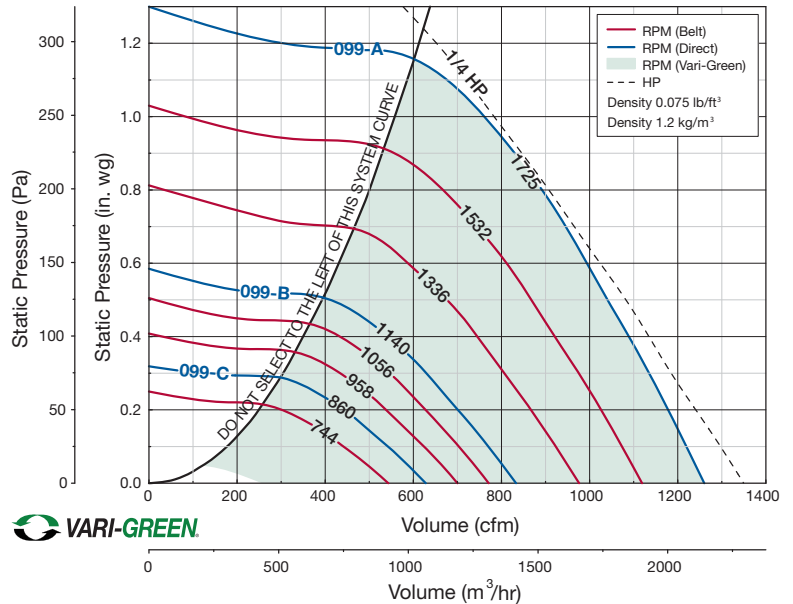

CUBE • CUE
CWB • CW

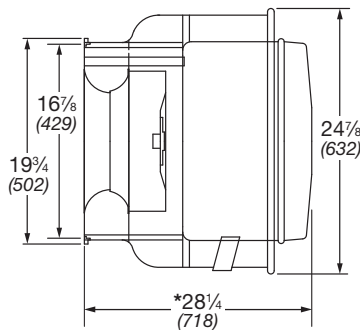

All dimensions in inches (millimeters), weight in pounds (kilograms).
* May be greater depending on motor.
^ Weight shown is largest cataloged open drip-proof motor.
Specifications and image for each model located at back of catalog.



	CUBE	CUE	CWB	CW
^Approximate Weight	58 (26)	53 (24)	58 (26)	53 (24)
Damper Size	12 x 12 (305 x 305)	12 x 12 (305 x 305)	12 x 12 (305 x 305)	12 x 12 (305 x 305)
Roof/Wall Opening	14 1/2 x 14 1/2 (368 x 368)	12 1/2 x 12 1/2 (318 X 318)		

Motor HP	Fan RPM	Static Pressure in Inches wg																					
		0	0.125	0.25	0.375	0.5	0.625	0.75	0.875	1	1.125												
099																							
1/4	VARI-GREEN VG-1/4	C-1/8	744	CFM	543	414																	
			BHP	0.02	0.02																		
			Sones	4.5	4.0																		
		B-1/6	860	CFM	628	518	376																
			BHP	0.03	0.03	0.03																	
			Sones	5.3	4.7	4.3																	
		A-1/4	1056	958	CFM	700	603	490															
				BHP	0.04	0.04	0.04																
				Sones	6.1	5.4	4.9																
			1238	1056	CFM	771	685	588	464														
				BHP	0.05	0.06	0.06	0.06															
				Sones	7.1	6.2	5.7	5.3															
	1336		1140	CFM	833	754	665	565	408														
			BHP	0.06	0.07	0.07	0.07	0.07															
			Sones	7.8	7.0	6.3	5.9	5.5															
	1434	1238	CFM	904	832	752	668	559															
		BHP	0.08	0.09	0.09	0.09	0.09																
		Sones	8.8	8.1	7.2	6.7	6.4																
	1532	1336	CFM	976	909	837	760	674	564														
		BHP	0.10	0.11	0.11	0.12	0.12	0.11															
		Sones	9.9	9.4	8.5	7.6	7.3	6.9															
	1630	1434	CFM	1047	986	920	848	776	687	567													
		BHP	0.13	0.13	0.14	0.14	0.14	0.14	0.14	0.14													
		Sones	10.8	10.4	9.7	8.8	8.3	8.0	7.6														
1725	1532	CFM	1119	1062	1001	935	868	794	705	583													
	BHP	0.15	0.16	0.17	0.17	0.18	0.18	0.17	0.16														
	Sones	11.9	11.4	10.9	10.0	9.4	9.1	8.8	8.4														
1725	1630	CFM	1191	1137	1080	1020	956	893	818	730	609												
	BHP	0.19	0.19	0.20	0.21	0.21	0.21	0.21	0.21	0.21	0.20												
	Sones	13.0	12.6	12.1	11.4	10.8	10.4	10.1	9.8	9.4													
1725	1725	CFM	1260	1209	1156	1100	1041	981	918	846	759	639											
	BHP	0.22	0.23	0.23	0.24	0.25	0.25	0.25	0.25	0.25	0.24	0.23											
	Sones	14.2	13.8	13.4	12.9	12.3	11.7	11.5	11.2	10.8	10.6												

MAXIMUM BHP AT A GIVEN RPM = (RPM/3099)³
MAXIMUM RPM = 1725
TIP SPEED (ft/min) = RPM x 2.846
MAXIMUM MOTOR FRAME SIZE = 56
AVERAGE DISCHARGE VELOCITY (FPM) = CFM/1.28

Performance certified is for installation type A: Free inlet, Free outlet. Power rating (Bhp) does not include transmission losses. Performance ratings do not include the effects of appurtenances (accessories). The sound ratings shown are loudness values in fan sones at 5 ft. (1.5 m) in a hemispherical free field calculated per AMCA Standard 301. Values shown are for installation type A: Free inlet hemispherical sone levels.

Roof Upblast/Sidewall Exhaust

Size-101HP: CUBE • CUE • CWB • CW

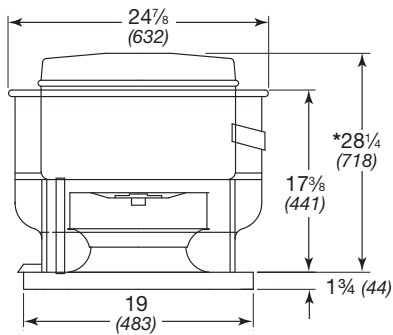

Direct Drive RPM
VG-2500 RPM

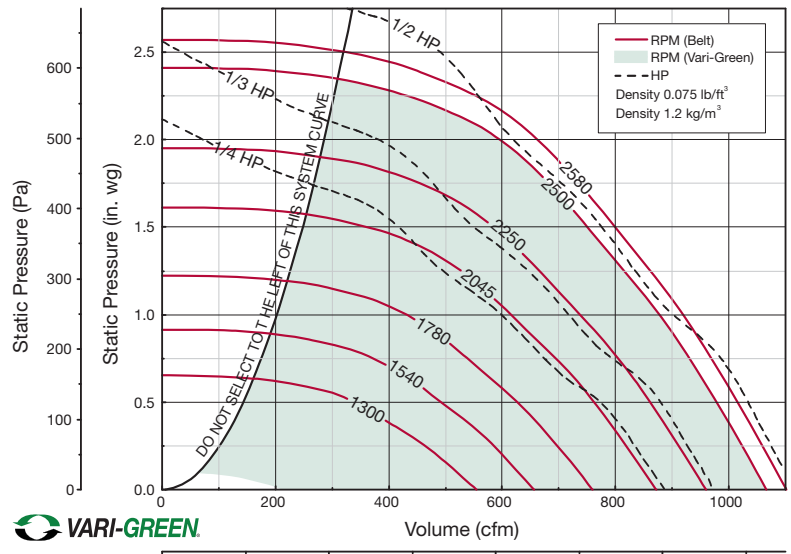

CUBE • CUE
CWB • CW

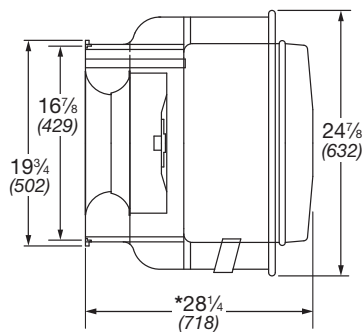

All dimensions in inches (millimeters), weight in pounds (kilograms).
* May be greater depending on motor.
^Weight shown is largest cataloged open drip-proof motor.
Specifications and image for each model located at back of catalog.

	CUBE	CUE	CWB	CW
^Approximate Weight	58 (26)	53 (24)	58 (26)	53 (24)
Damper Size	12 x 12 (305 x 305)		12 x 12 (305 x 305)	
Roof/Wall Opening	14½ x 14½ (368 x 368)		12½ x 12½ (318 X 318)	

Motor HP	Fan RPM	Static Pressure in Inches wg											
		0.5	0.625	0.75	1	1.25	1.5	1.75	2	2.25	2.5		
101HP													
1/4	VG-1/2	1300	CFM	335	182								
			BHP	0.067	0.056								
			Sones	6	6.3								
		1420	CFM	419	350	191							
			BHP	0.088	0.088	0.073							
			Sones	6.8	6.6	6.9							
	1540	CFM	491	438	371								
		BHP	0.11	0.11	0.11								
		Sones	7.8	7.5	7.3								
	1660	CFM	560	512	461	262							
		BHP	0.14	0.14	0.14	0.12							
		Sones	8.9	8.6	8.4	8.3							
1780	CFM	627	583	538	430								
	BHP	0.17	0.17	0.17	0.17								
	Sones	10.3	9.9	9.6	9.1								
1900	CFM	688	651	610	520	382							
	BHP	0.2	0.21	0.21	0.21	0.19							
	Sones	12.1	11.4	11	10.5	10.2							
2045	CFM	761	729	693	615	522	346						
	BHP	0.24	0.26	0.26	0.26	0.26	0.23						
	Sones	13.9	13.5	12.7	12.1	11.5	11.4						
1/3	2150	CFM	812	782	752	678	600	500					
		BHP	0.28	0.29	0.3	0.3	0.3	0.3					
		Sones	14.1	14.1	13.5	12.5	12	11.5					
	2250	CFM	860	832	804	737	665	579	456				
		BHP	0.32	0.33	0.34	0.35	0.35	0.35	0.32				
		Sones	14.4	14.4	14.2	13.2	12.5	11.9	11.6				
1/2	2500	CFM	977	954	929	878	815	750	677	595	414		
		BHP	0.44	0.44	0.45	0.48	0.48	0.48	0.48	0.48	0.42		
		Sones	15.9	15.6	15.3	15	14.4	13.6	12.9	12.5	12.2		
	2580	CFM	1014	992	969	919	861	799	735	655	550	323	
		BHP	0.48	0.48	0.49	0.52	0.53	0.53	0.53	0.53	0.49	0.43	
		Sones	16.8	16.4	16	15.7	15.1	14.4	13.7	13.2	12.9	12.5	

MAXIMUM BHP AT A GIVEN RPM = (RPM/3195)³
 MAXIMUM RPM = 2580
 TIP SPEED (ft/min) = RPM x 2.913
 MAXIMUM MOTOR FRAME SIZE = 56
 AVERAGE DISCHARGE VELOCITY (FPM) = CFM/1.28

Performance certified is for installation type A: Free inlet, Free outlet. Power rating (Bhp) does not include transmission losses. Performance ratings do not include the effects of appurtenances (accessories). The sound ratings shown are loudness values in fan sones at 5 ft. (1.5 m) in a hemispherical free field calculated per AMCA Standard 301. Values shown are for installation type A: Free inlet hemispherical sone levels.

Roof Upblast/Sidewall Exhaust

Size-121: CUBE • CUE • CWB • CW

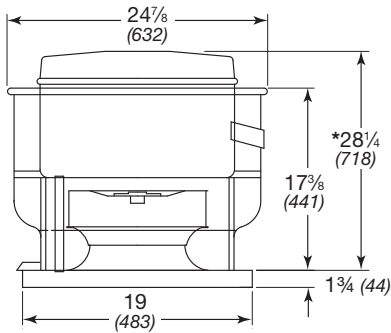

Direct Drive RPM

C-860 RPM
B-1140 RPM
A-1725 RPM
VG-1725 RPM

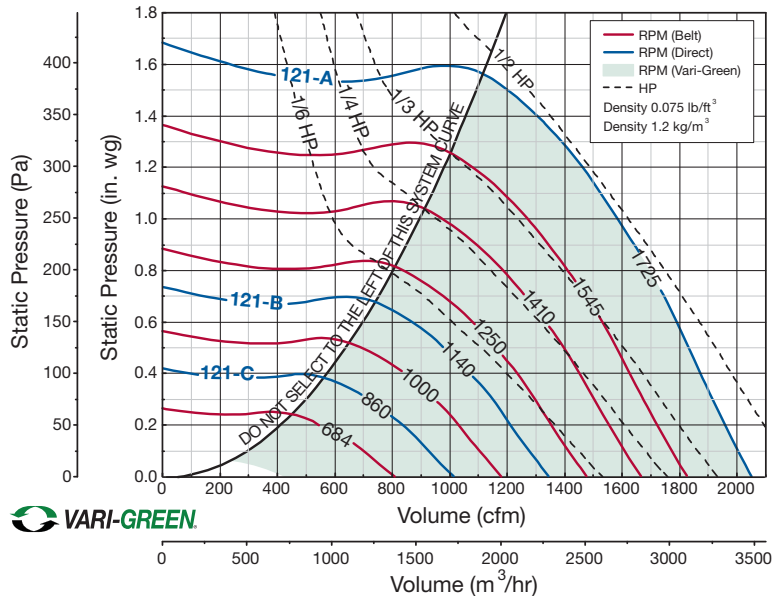

CUBE • CUE CWB • CW

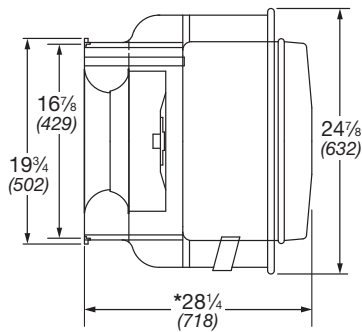

All dimensions in inches (millimeters), weight in pounds (kilograms).
 * May be greater depending on motor.
 ^ Weight shown is largest cataloged open drip-proof motor.
 Specifications and image for each model located at back of catalog.

	CUBE	CUE	CWB (30)	CW
^Approximate Weight	66 (30)	64 (29)	66 (30)	53 (24)
Damper Size	12 x 12 (305 x 305)			
Roof/Wall Opening	14 1/2 x 14 1/2 (368 x 368)		12 1/2 x 12 1/2 (318 X 318)	

Motor HP	Fan RPM	Static Pressure in Inches wg											
		0	0.125	0.25	0.375	0.5	0.625	0.75	1	1.25	1.5		
121													
1/4	VG-1/2	684	CFM	808	669								
			BHP	0.02	0.03								
			Sones	4.4	4.4								
		772	CFM	912	789	630							
			BHP	0.04	0.04	0.043							
			Sones	4.8	5	5.1							
	C-1/8	860	CFM	1015	905	781	581						
			BHP	0.05	0.05	0.06	0.06						
			Sones	5.3	5.7	5.6	5.7						
		1000	CFM	1181	1084	993	870	691					
			BHP	0.08	0.08	0.09	0.09	0.09					
			Sones	6.2	6.6	6.8	6.7	6.7					
B-1/6	1140	CFM	1346	1261	1180	1091	981	833					
		BHP	0.11	0.12	0.13	0.13	0.14	0.14					
		Sones	7.4	7.9	8.2	8.2	8	8.1					
	1250	CFM	1476	1397	1323	1250	1159	1053	916				
		BHP	0.15	0.16	0.17	0.17	0.18	0.18	0.18				
		Sones	8.8	9.3	9.9	9.9	10	9.8	9.8				
1410	CFM	1665	1595	1528	1463	1398	1315	1224	965				
	BHP	0.21	0.22	0.23	0.24	0.25	0.26	0.26	0.25				
	Sones	11.1	11.6	12.2	12.5	12.6	12.7	12.7	12.3				
1/3	1480	CFM	1748	1681	1617	1555	1493	1421	1338	1132			
		BHP	0.25	0.26	0.27	0.28	0.29	0.29	0.30	0.30			
		Sones	11.9	12.4	13.1	13.5	13.7	13.8	13.8	13.6			
	1545	CFM	1824	1760	1699	1639	1580	1518	1441	1262	990		
		BHP	0.28	0.29	0.30	0.31	0.32	0.33	0.34	0.34	0.33		
		Sones	12.8	13.4	14	14.5	14.7	14.8	14.9	14.9	14.6		
1/2	1635	CFM	1931	1870	1811	1755	1699	1643	1577	1424	1226		
		BHP	0.33	0.34	0.36	0.37	0.38	0.39	0.40	0.41	0.40		
		Sones	14.1	14.7	15.2	15.9	16.2	16.4	16.6	16.7	16.5		
	A-1/2	1725	CFM	2037	1979	1923	1869	1816	1763	1710	1571	1406	
			BHP	0.39	0.40	0.41	0.43	0.44	0.45	0.46	0.47	0.48	
			Sones	15.6	16.1	16.7	17.3	17.9	18.2	18.4	18.7	18.6	

MAXIMUM BHP AT A GIVEN RPM = (RPM/2199)³
 MAXIMUM RPM = 1725
 TIP SPEED (ft/min) = RPM x 3.419
 MAXIMUM MOTOR FRAME SIZE = 56
 AVERAGE DISCHARGE VELOCITY (FPM) = CFM/1.28

Performance certified is for installation type A: Free inlet, Free outlet. Power rating (Bhp) does not include transmission losses. Performance ratings do not include the effects of appurtenances (accessories). The sound ratings shown are loudness values in fan sones at 5 ft. (1.5 m) in a hemispherical free field calculated per AMCA Standard 301. Values shown are for installation type A: Free inlet hemispherical sone levels.

Roof Upblast/Sidewall Exhaust

Size-131: CUBE • CUE • CWB • CW

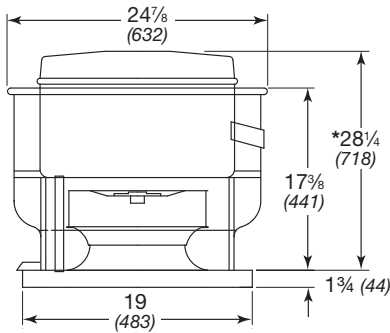

Direct Drive RPM

C-860 RPM
B-1140 RPM
A-1725 RPM
VG-1725 RPM

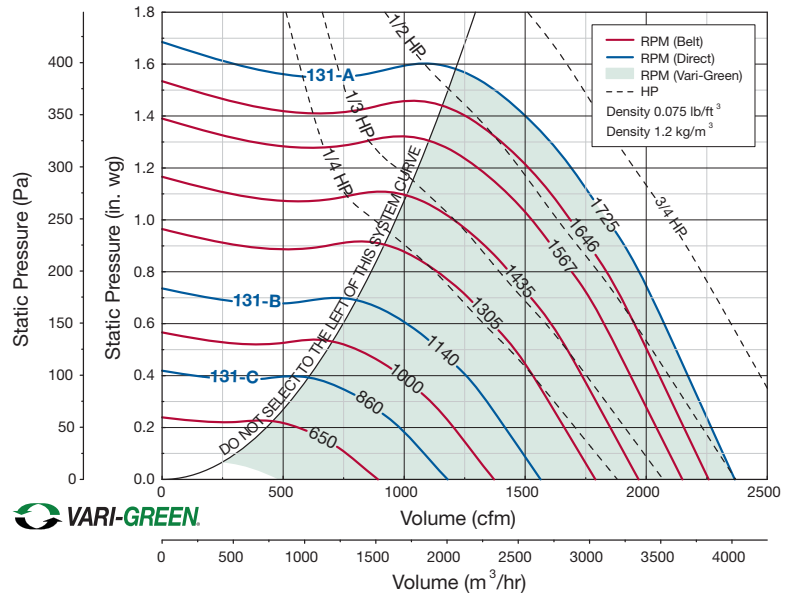

CUBE • CUE

CWB • CW

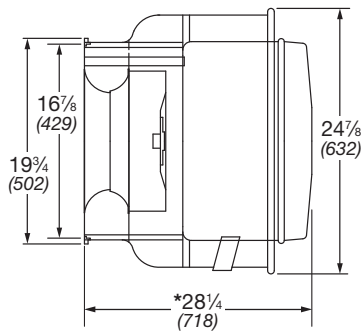

All dimensions in inches (millimeters), weight in pounds (kilograms).
 * May be greater depending on motor.
 ^ Weight shown is largest cataloged open drip-proof motor.
 Specifications and image for each model located at back of catalog.

	CUBE	CUE	CWB	CW
^Approximate Weight	66 (30)	64 (29)	66 (30)	53 (24)
Damper Size	12 x 12 (305 x 305)		12 x 12 (305 x 305)	
Roof/Wall Opening	14 1/2 x 14 1/2 (368 x 368)		12 1/2 x 12 1/2 (318 X 318)	

Motor HP	Fan RPM	Static Pressure in Inches wg											
		0	0.125	0.25	0.375	0.5	0.625	0.75	1	1.25	1.5		
131													
1/4	VG-3/4	650	CFM	892	724								
			BHP	0.03	0.03								
			Sones	6.2	6.0								
		755	CFM	1036	895	697							
			BHP	0.04	0.05	0.05							
			Sones	7.2	7.0	6.3							
	C-1/8	860	CFM	1180	1057	914	675						
			BHP	0.06	0.07	0.07	0.07						
			Sones	8.5	8.3	7.7	6.9						
		1000	CFM	1372	1267	1158	1016	801					
			BHP	0.10	0.11	0.11	0.12	0.11					
			Sones	10.7	10.5	10.0	9.2	8.3					
B-1/6	1140	CFM	1564	1471	1379	1280	1144	964					
		BHP	0.14	0.15	0.16	0.17	0.17	0.17					
		Sones	12.5	12.2	11.8	11.2	10.3	9.7					
	1305	CFM	1790	1709	1629	1547	1458	1340	1201				
		BHP	0.22	0.23	0.24	0.25	0.26	0.26	0.26				
		Sones	14.6	14.3	13.9	13.5	13.0	12.0	11.5				
1/3	1435	CFM	1968	1895	1822	1749	1671	1586	1479	1198			
		BHP	0.29	0.30	0.31	0.32	0.33	0.34	0.35	0.33			
		Sones	15.7	15.5	15.1	14.8	14.3	13.8	13.1	11.9			
	1488	CFM	2041	1970	1900	1829	1756	1679	1580	1342			
		BHP	0.32	0.33	0.35	0.36	0.37	0.38	0.39	0.38			
		Sones	16.2	15.9	15.7	15.4	15.0	14.5	13.9	12.7			
1/2	1567	CFM	2149	2082	2015	1948	1881	1808	1728	1527	1222		
		BHP	0.37	0.39	0.40	0.41	0.43	0.44	0.45	0.45	0.42		
		Sones	17.0	16.8	16.5	16.3	15.9	15.5	15.0	13.8	12.6		
	1646	CFM	2258	2194	2130	2066	2002	1935	1865	1686	1458		
		BHP	0.43	0.45	0.46	0.47	0.49	0.50	0.51	0.52	0.51		
		Sones	17.9	17.6	17.4	17.2	16.9	16.5	16.1	15.1	14.0		
A-1/2	1725	CFM	2366	2305	2244	2183	2122	2061	1994	1838	1646	1365	
		BHP	0.50	0.51	0.53	0.54	0.56	0.57	0.58	0.60	0.60	0.57	
		Sones	18.8	18.6	18.4	18.2	18.0	17.6	17.2	16.4	15.3	14.1	

MAXIMUM BHP AT A GIVEN RPM = (RPM/2041)³
 MAXIMUM RPM = 1725
 TIP SPEED (ft/min) = RPM x 3.420
 MAXIMUM MOTOR FRAME SIZE = 56
 AVERAGE DISCHARGE VELOCITY (FPM) = CFM/1.28

Performance certified is for installation type A: Free inlet, Free outlet. Power rating (Bhp) does not include transmission losses. Performance ratings do not include the effects of appurtenances (accessories). The sound ratings shown are loudness values in fan sones at 5 ft. (1.5 m) in a hemispherical free field calculated per AMCA Standard 301. Values shown are for installation type A: Free inlet hemispherical sone levels.

Roof Upblast/Sidewall Exhaust

Size-140: USGF

Size-141: CUBE • CUE • CWB • CW

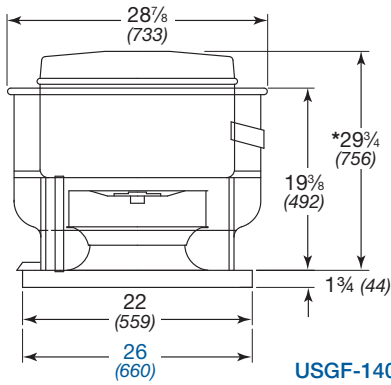

USGF-140 • CUBE • CUE

Direct Drive RPM

C-860 RPM
B-1140 RPM
A-1725 RPM
VG-1725 RPM

CWB • CW

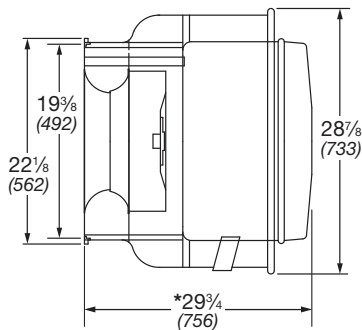

All dimensions in inches (millimeters), weight in pounds (kilograms).
 * May be greater depending on motor.
 ^ Weight shown is largest cataloged open drip-proof motor.
 Specifications and image for each model located at back of catalog.

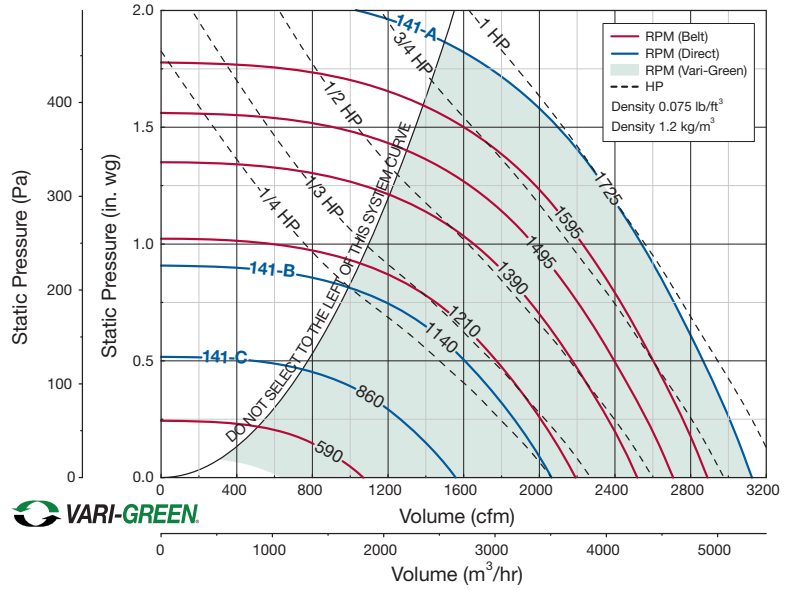

	CUBE	CUE	USGF	CWB	CW
^Approximate Weight	84 (38)	90 (41)	125 (57)	84 (38)	90 (41)
Damper Size	16 x 16 (406 x 406)	N/A	N/A	15 x 15 (381 x 381)	15 x 15 (381 x 381)
Roof/Wall Opening	18½ x 18½ (470 x 470)			15½ x 15½ (394 X 394)	

Motor HP	Fan RPM	Static Pressure in Inches wg											
		0	0.125	0.25	0.375	0.5	0.75	1	1.25	1.50	1.75		
140 / 141													
1/4	VG-3/4 or 1	590	CFM	1069	851								
			BHP	0.04	0.04								
			Sones	5.0	4.5								
		725	CFM	1313	1151	917							
			BHP	0.06	0.07	0.07							
			Sones	5.1	5.0	4.4							
	C-1/8	860	CFM	1558	1427	1264	1034						
			BHP	0.11	0.12	0.12	0.12						
			Sones	7.3	7.5	7.1	6.5						
		1105	CFM	2001	1906	1793	1667	1515	998				
			BHP	0.23	0.24	0.25	0.26	0.26	0.23				
			Sones	10.9	10.8	10.6	10.3	10.0	9.6				
1/3	B-1/4	1140	CFM	2065	1973	1864	1745	1605	1167				
			BHP	0.25	0.26	0.27	0.28	0.29	0.27				
			Sones	11.3	11.3	11.0	10.7	10.3	10.0				
		1210	CFM	2192	2106	2006	1896	1773	1443				
			BHP	0.30	0.31	0.32	0.33	0.34	0.34				
			Sones	12.2	12.2	11.7	11.6	11.2	10.9				
	1/2	1390	CFM	2518	2445	2362	2271	2174	1949	1643			
			BHP	0.45	0.47	0.48	0.50	0.51	0.52	0.51			
			Sones	14.9	14.7	14.2	13.2	12.9	12.1	11.0			
		1495	CFM	2708	2640	2565	2483	2396	2202	1967	1617		
			BHP	0.56	0.58	0.60	0.61	0.62	0.64	0.65	0.61		
			Sones	17.2	16.5	16.3	15.6	13.9	12.5	12.2	10.8		
3/4	1550	CFM	2808	2743	2671	2594	2509	2329	2110	1823	1349		
		BHP	0.63	0.64	0.66	0.68	0.69	0.71	0.72	0.70	0.62		
		Sones	18.7	17.8	17.5	17.7	14.9	12.9	12.5	11.6	10.2		
	1595	CFM	2889	2826	2757	2683	2602	2430	2225	1968	1568		
		BHP	0.69	0.70	0.72	0.74	0.75	0.77	0.79	0.78	0.71		
		Sones	20.0	19.0	18.5	19.5	16.1	13.3	12.3	12.6	11.6		
1	A-1	1725	CFM	3124	3066	3005	2936	2865	2711	2539	2339	2085	1704
			BHP	0.87	0.88	0.90	0.92	0.94	0.97	0.99	1.00	0.98	0.91
			Sones	26.0	23.0	22.0	24.0	24.0	15.1	13.4	14.3	13.8	13.8

MAXIMUM BHP AT A GIVEN RPM = $(RPM/1726)^3$
 MAXIMUM RPM = 1725
 TIP SPEED (ft/min) = $RPM \times 3.829$
 MAXIMUM MOTOR FRAME SIZE = 145T
 AVERAGE DISCHARGE VELOCITY (FPM) = $CFM/1.72$

Performance certified is for installation type A: Free inlet, Free outlet. Power rating (Bhp) does not include transmission losses. Performance ratings do not include the effects of appurtenances (accessories). The sound ratings shown are loudness values in fan sones at 5 ft. (1.5 m) in a hemispherical free field calculated per AMCA Standard 301. Values shown are for installation type A: Free inlet hemispherical sone levels.

Roof Upblast/Sidewall Exhaust

Size-160: USGF

Size-161: CUBE • CUE • CWB • CW

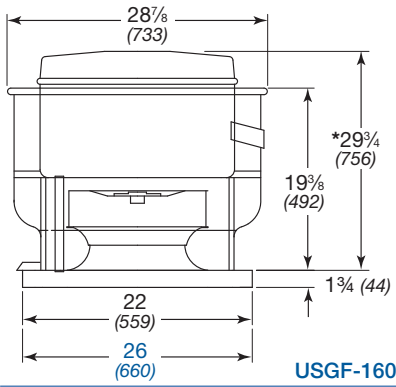

Direct Drive RPM

C-860 RPM
B-1140 RPM
A-1725 RPM
VG-1725 RPM

USGF-160 • CUBE • CUE

CWB • CW

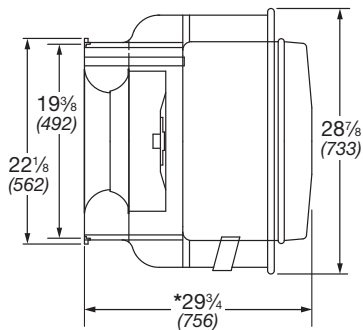

All dimensions in inches (millimeters), weight in pounds (kilograms).
 * May be greater depending on motor.
 ^ Weight shown is largest cataloged open drip-proof motor.
 Specifications and image for each model located at back of catalog.

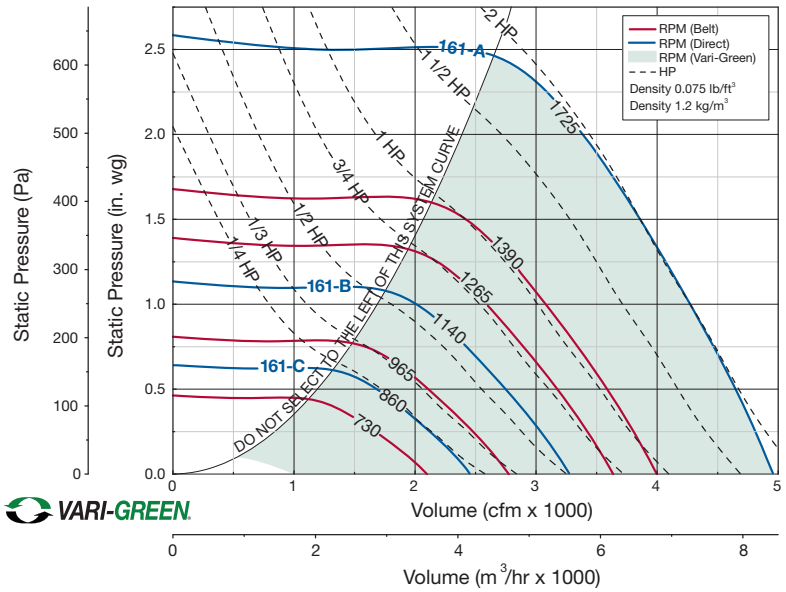

	CUBE	CUE	USGF	CWB	CW
^Approximate Weight	87 (39)	90 (41)	131 (59)	87 (39)	90 (41)
Damper Size	16 x 16 (406 x 406)	N/A	N/A	15 x 15 (381 x 381)	15 x 15 (381 x 381)
Roof/Wall Opening	18½ x 18½ (470 x 470)			15½ x 15½ (394 X 394)	

Motor HP	Fan RPM	Static Pressure in Inches wg											
		0	0.125	0.25	0.375	0.5	0.625	0.75	0.875	1	1.5		
160 / 161													
1/4	VG-3/4 or 1	730	CFM	2098	1905	1669	1389						
			BHP	0.13	0.15	0.15	0.15						
			Sones	8.1	8	7.8	7.8						
		805	CFM	2314	2143	1937	1708	1396					
			BHP	0.18	0.20	0.20	0.20	0.19					
			Sones	9.5	9.2	8.9	8.8	8.7					
	C-1/4	860	CFM	2472	2315	2126	1918	1680					
			BHP	0.22	0.24	0.25	0.25	0.24					
			Sones	10.7	10.2	9.9	9.7	9.5					
		875	CFM	2515	2362	2177	1974	1744	1365				
			BHP	0.23	0.26	0.26	0.26	0.26	0.24				
			Sones	11	10.6	10.1	9.9	9.7	9.7				
1/3	965	CFM	2774	2637	2477	2300	2109	1893	1584				
		BHP	0.31	0.34	0.35	0.35	0.35	0.34	0.33				
		Sones	12.4	12	11.5	11.2	10.8	10.6	10.6				
	1110	CFM	3191	3072	2941	2796	2641	2475	2297	1770			
		BHP	0.47	0.51	0.53	0.53	0.54	0.53	0.52	0.49			
		Sones	15	14.6	14.2	13.8	13.5	13.1	12.9	12.5			
3/4	B-1/2	1140	CFM	3277	3161	3035	2896	2745	2587	2421	1983		
			BHP	0.51	0.55	0.57	0.57	0.58	0.58	0.57	0.55		
			Sones	15.7	15.2	14.8	14.4	14.1	13.8	13.5	13.2		
		1265	CFM	3636	3532	3426	3301	3172	3036	2894	2583	2163	
			BHP	0.70	0.74	0.77	0.78	0.79	0.79	0.79	0.78	0.75	
			Sones	18.5	18.1	17.6	17.2	16.8	16.5	16.3	15.8	15.6	
1	VG-1	1300	CFM	3737	3636	3534	3413	3290	3157	3022	2729	2357	
			BHP	0.76	0.80	0.84	0.85	0.85	0.86	0.86	0.84	0.82	
			Sones	19.1	18.7	18.3	17.9	17.5	17.2	17	16.5	16.3	
		1390	CFM	3996	3901	3806	3698	3584	3464	3340	3078	2785	2394
			BHP	0.93	0.97	1.01	1.03	1.04	1.04	1.05	1.04	1.03	1.00
			Sones	21	21	20	19.7	19.3	19	18.8	18.4	18	17.9
A-2	1725	CFM	4959	4882	4806	4729	4646	4554	4463	4269	4070	3855	
		BHP	1.77	1.83	1.88	1.94	1.97	1.97	1.98	2.00	2.01	1.99	
		Sones	30	29	29	29	28	28	27	27	27	26	

MAXIMUM BHP AT A GIVEN RPM = (RPM/1365)³
 MAXIMUM RPM = 1725
 TIP SPEED (ft/min) = RPM x 4.352
 MAXIMUM MOTOR FRAME SIZE = 145T
 AVERAGE DISCHARGE VELOCITY (FPM) = CFM/1.72

Performance certified is for installation type A: Free inlet, Free outlet. Power rating (Bhp) does not include transmission losses. Performance ratings do not include the effects of appurtenances (accessories). The sound ratings shown are loudness values in fan sones at 5 ft. (1.5 m) in a hemispherical free field calculated per AMCA Standard 301. Values shown are for installation type A: Free inlet hemispherical sone levels.

Roof Upblast/Sidewall Exhaust

Size-160HP: USGF

Size-161HP: CUBE • CUE • CWB • CW

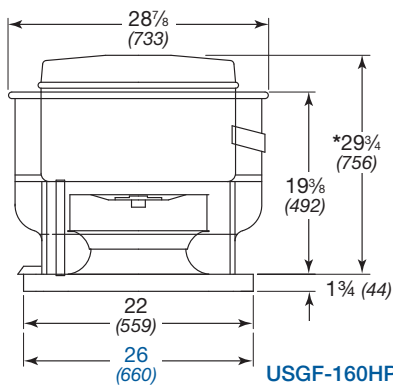

USGF-160HP • CUBE • CUE

Direct Drive RPM

B-1140 RPM
A-1725 RPM
VG-1725 RPM

CWB • CW

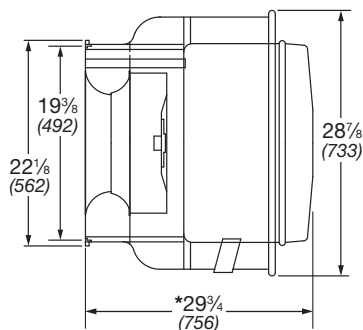

All dimensions in inches (millimeters), weight in pounds (kilograms).

* May be greater depending on motor.
^ Weight shown is largest cataloged open drip-proof motor.

Specifications and image for each model located at back of catalog.

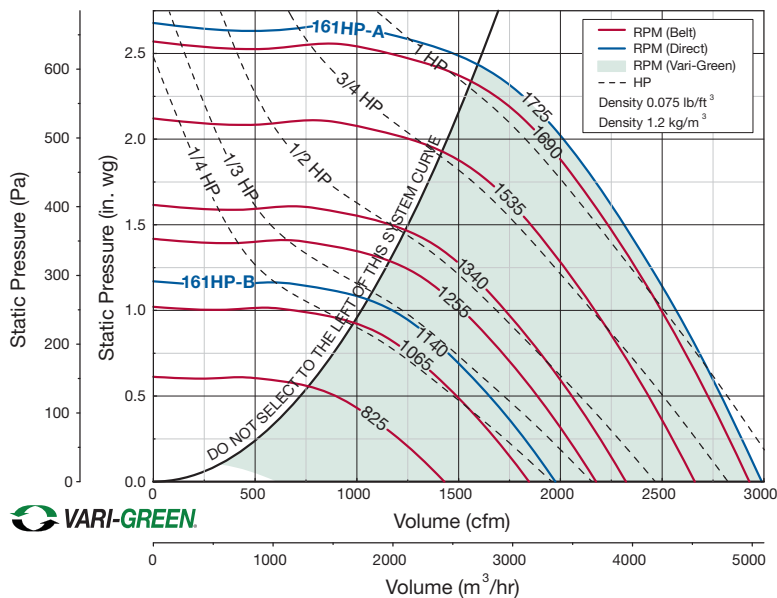

	CUBE	CUE	USGF	CWB	CW
^Approximate Weight	87 (39)	90 (41)	131 (59)	87 (39)	90 (41)
Damper Size	16 x 16 (406 x 406)	N/A	N/A	15 x 15 (381 x 381)	
Roof/Wall Opening	18 1/2 x 18 1/2 (470 x 470)			15 1/2 x 15 1/2 (394 X 394)	

Motor HP	Fan RPM	Static Pressure in Inches wg												
		0.5	0.625	0.75	0.875	1	1.25	1.5	1.75	2	2.25			
160HP / 161HP														
1/4	VG-3/4 or 1	825	CFM 889											
			BHP 0.12											
			Sones 6.1											
	1/3	B-1/3	945	CFM 1213	1062									
				BHP 0.18	0.18									
				Sones 8.9	8.4									
	1/2	VARI-GREEN	1065	CFM 1487	1377	1252	1093							
				BHP 0.25	0.26	0.26	0.26							
				Sones 11.1	10.7	10.3	9.7							
3/4			1140	1140	CFM 1645	1552	1444	1322	1175					
					BHP 0.31	0.32	0.32	0.32	0.32					
					Sones 12.7	12.5	12	11.6	11					
1	1165	1165	CFM 1697	1608	1504	1395	1252							
			BHP 0.32	0.33	0.34	0.34	0.34							
			Sones 12.9	12.8	12.3	11.8	11.2							
1	VG-1	1255	1255	CFM 1882	1799	1715	1617	1519	1218					
				BHP 0.40	0.41	0.42	0.43	0.43	0.42					
				Sones 13.1	12.8	12.5	12	11.5	10.6					
		1	1340	1340	CFM 2053	1975	1897	1816	1724	1513				
					BHP 0.48	0.49	0.50	0.51	0.52	0.52				
					Sones 14.2	13.8	13.3	12.9	12.4	11.3				
1	1535	1535	CFM 2433	2368	2301	2233	2165	2015	1855	1638				
			BHP 0.70	0.72	0.73	0.74	0.76	0.78	0.79	0.78				
			Sones 18.1	17.7	17.3	16.9	16.5	15.6	14.7	13.5				
1	1550	1550	CFM 2461	2398	2331	2264	2197	2051	1892	1683	1352			
			BHP 0.72	0.74	0.75	0.76	0.78	0.80	0.81	0.81	0.77			
			Sones 18.3	17.9	17.5	17.1	16.7	15.9	15	13.8	14.5			
1	1690	1690	CFM 2722	2671	2611	2550	2488	2365	2228	2082	1899	1664		
			BHP 0.92	0.94	0.95	0.97	0.98	1.01	1.03	1.05	1.05	1.03		
			Sones 21	21	20	19.8	19.4	18.7	18	17.3	16.1	15.1		
1	A-1 1/2	1725	CFM 2787	2736	2680	2620	2560	2439	2310	2167	2003	1810		
			BHP 0.97	0.99	1.01	1.03	1.04	1.07	1.10	1.11	1.12	1.11		
			Sones 22	21	21	21	20	19.4	18.7	18	17.1	16		

MAXIMUM BHP AT A
GIVEN RPM = (RPM/1660)³
MAXIMUM RPM = 1725
TIP SPEED (ft/min) = RPM x 4.352
MAXIMUM MOTOR FRAME SIZE = 145T
AVERAGE DISCHARGE VELOCITY
(FPM) = CFM/1.72

Performance certified is for installation type A: Free inlet, Free outlet. Power rating (Bhp) does not include transmission losses. Performance ratings do not include the effects of appurtenances (accessories). The sound ratings shown are loudness values in fan sones at 5 ft. (1.5 m) in a hemispherical free field calculated per AMCA Standard 301. Values shown are for installation type A: Free inlet hemispherical sone levels.

Roof Upblast/Sidewall Exhaust

Size-160XP: USGF

Size-161XP: CUBE

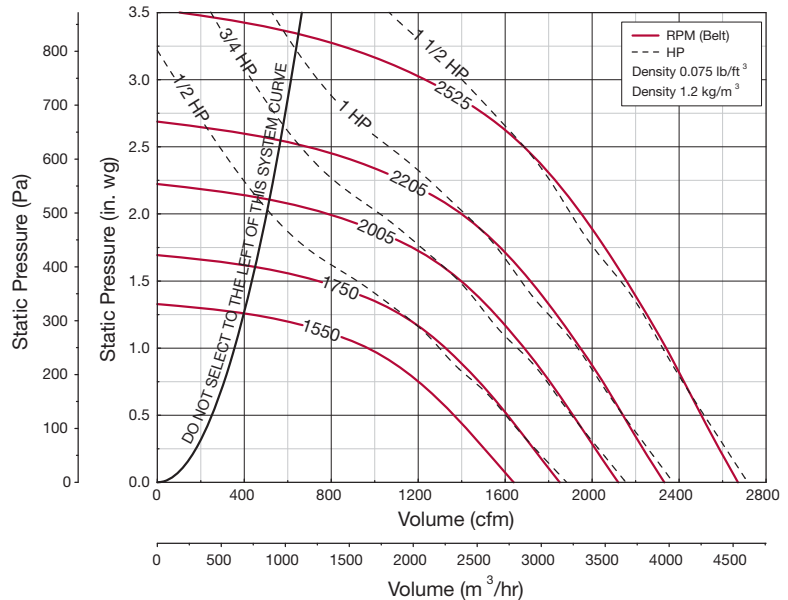
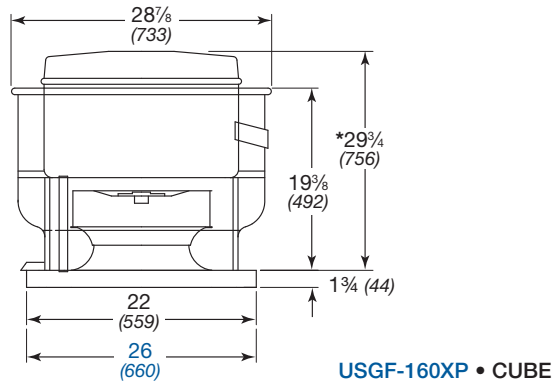

All dimensions in inches (millimeters), weight in pounds (kilograms).

* May be greater depending on motor.

^Weight shown is largest cataloged open drip-proof motor.

Specifications and image for each model located at back of catalog.

	CUBE	USGF
^Approximate Weight	87 (39)	131 (59)
Damper Size	16 x 16 (406 x 406)	N/A
Roof/Wall Opening	18½ x 18½ (470 x 470)	

Motor HP	Fan RPM	Static Pressure in Inches wg										
		1	1.25	1.5	1.75	2	2.25	2.5	2.75	3	3.25	
160XP / 161XP												
1/2	1550	CFM	968									
		BHP	0.34									
		Sones	10.0									
	1648	CFM	1157	854								
		BHP	0.42	0.39								
		Sones	11.1	10.1								
1750	CFM	1322	1116	726								
	BHP	0.52	0.49	0.43								
	Sones	12.1	11.4	10.6								
3/4	1880	CFM	1515	1359	1139	744						
		BHP	0.7	0.6	0.6	0.5						
		Sones	13.7	13.1	12.2	11.8						
	1942	CFM	1599	1456	1271	984						
		BHP	0.71	0.7	0.68	0.63						
		Sones	14.4	14	13.2	12.4						
2005	CFM	1684	1552	1392	1161	777						
	BHP	0.77	0.78	0.76	0.72	0.63						
	Sones	15.0	14.8	14.1	13.4	13.2						
1	2138	CFM	1861	1743	1611	1451	1226	869				
		BHP	0.9	1.0	0.9	0.9	0.9	0.8				
		Sones	16.6	16.4	15.9	15.4	14.8	14.8				
	2205	CFM	1946	1834	1713	1578	1395	1127	634			
		BHP	1.01	1.03	1.04	1.01	0.99	0.92	0.73			
		Sones	17.5	17.3	17	16.4	15.8	15.5	16.4			
1½	2310	CFM	2065	1974	1865	1741	1597	1415	1134	644		
		BHP	1.17	1.18	1.2	1.18	1.16	1.12	1.04	0.83		
		Sones	18.8	18.7	18.5	18.1	17.5	17	16.9	18.2		
	2432	CFM	2206	2132	2031	1926	1804	1660	1483	1225	826	
		BHP	1.36	1.36	1.38	1.4	1.38	1.35	1.31	1.23	1.07	
		Sones	21	20	20	20	19.6	19.1	18.7	18.7	19.8	
2525	CFM	2313	2241	2155	2056	1946	1828	1676	1487	1221	810	
	BHP	1.52	1.52	1.54	1.56	1.56	1.53	1.5	1.45	1.35	1.16	
	Sones	22	22	22	22	21	21	20	20	20	22	

MAXIMUM BHP AT A GIVEN RPM = $(RPM/2170)^3$
 MAXIMUM RPM = 2525
 TIP SPEED (ft/min) = $RPM \times 3.534$
 MAXIMUM MOTOR FRAME SIZE = 145T
 AVERAGE DISCHARGE VELOCITY (FPM) = $CFM/1.72$

Performance certified is for installation type A: Free inlet, Free outlet. Power rating (Bhp) does not include transmission losses. Performance ratings do not include the effects of appurtenances (accessories). The sound ratings shown are loudness values in fan sones at 5 ft. (1.5 m) in a hemispherical free field calculated per AMCA Standard 301. Values shown are for installation type A: Free inlet hemispherical sone levels.

Roof Upblast/Sidewall Exhaust

Size-180: CUBE • CUE • USGF CWB • CW

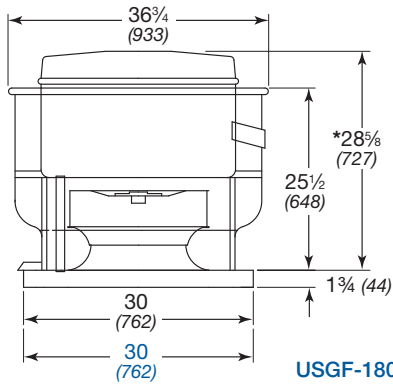

USGF-180 • CUBE • CUE

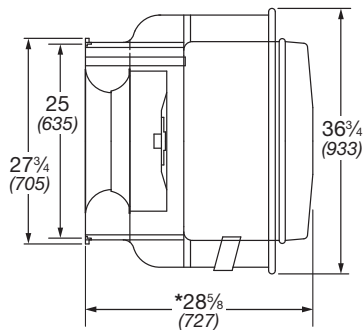

Direct Drive RPM

C-860 RPM
B-1140 RPM
VG-1000 RPM

CWB • CW

All dimensions in inches (millimeters), weight in pounds (kilograms).
 * May be greater depending on motor.
 ^ Weight shown is largest cataloged open drip-proof motor.
 Specifications and image for each model located at back of catalog.

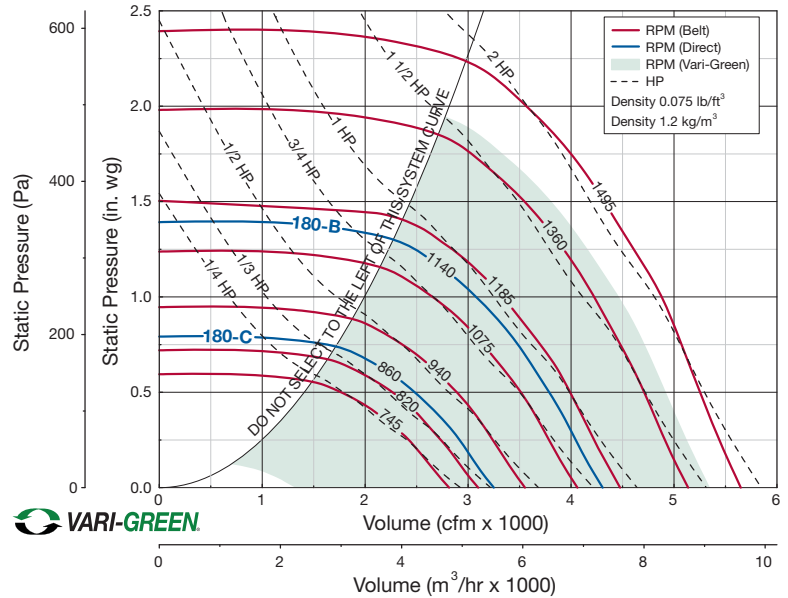

	CUBE	CUE	USGF	CWB	CW
^Approximate Weight	126 (57)	142 (64)	190 (86)	126 (57)	142 (64)
Damper Size	18 x 18 (457 x 457)	N/A	N/A	17 x 17 (432 x 432)	17 x 17 (432 x 432)
Roof/Wall Opening	20½ x 20½ (521 x 521)			17½ x 17½ (445 X 445)	

Motor HP	Fan RPM	Static Pressure in Inches wg											
		0	0.125	0.25	0.5	0.75	1	1.25	1.5	1.75	2		
180													
1/4	VG-3/4 or 1	745	CFM	2815	2617	2448	1763						
			BHP	0.22	0.24	0.26	0.25						
1/3	VARI-GREEN	820	CFM	3098	2916	2759	2257						
			BHP	0.30	0.32	0.34	0.34						
1/2	C-1/2	860	CFM	3249	3074	2922	2474						
			BHP	0.34	0.37	0.39	0.40						
1/2	VARI-GREEN	940	CFM	3551	3389	3243	2879	2363					
			BHP	0.45	0.47	0.49	0.52	0.50					
3/4	VG-1	1000	CFM	3778	3625	3486	3190	2738					
			BHP	0.54	0.57	0.59	0.63	0.62					
3/4	VARI-GREEN	1075	CFM	4061	3919	3786	3554	3141	2652				
			BHP	0.67	0.70	0.73	0.78	0.78	0.75				
1	B-1	1140	CFM	4307	4173	4045	3822	3470	3072	2477			
			BHP	0.80	0.83	0.86	0.91	0.93	0.92	0.85			
1	VARI-GREEN	1185	CFM	4477	4348	4224	4005	3703	3336	2841			
			BHP	0.90	0.93	0.96	1.01	1.04	1.04	0.99			
1½	VG-2	1275	CFM	4817	4697	4578	4369	4163	3799	3437	2930		
			BHP	1.12	1.15	1.19	1.24	1.30	1.30	1.28	1.22		
1½	VARI-GREEN	1360	CFM	5138	5026	4913	4710	4532	4232	3912	3537	3023	
			BHP	1.36	1.39	1.43	1.49	1.56	1.58	1.58	1.54	1.46	
2	X	1495	CFM	5648	5546	5443	5254	5082	4921	4598	4313	3983	3564
			BHP	1.80	1.84	1.89	1.96	2.02	2.10	2.10	2.10	2.06	1.99
2	VARI-GREEN	1495	CFM	5648	5546	5443	5254	5082	4921	4598	4313	3983	3564
			BHP	1.80	1.84	1.89	1.96	2.02	2.10	2.10	2.10	2.06	1.99

MAXIMUM BHP AT A GIVEN RPM = (RPM/1167)³
 MAXIMUM RPM = 1495
 TIP SPEED (ft/min) = RPM x 4.843
 MAXIMUM MOTOR FRAME SIZE = 184T
 AVERAGE DISCHARGE VELOCITY (FPM) = CFM/2.92

Performance certified is for installation type A: Free inlet, Free outlet. Power rating (Bhp) does not include transmission losses. Performance ratings do not include the effects of appurtenances (accessories). The sound ratings shown are loudness values in fan sones at 5 ft. (1.5 m) in a hemispherical free field calculated per AMCA Standard 301. Values shown are for installation type A: Free inlet hemispherical sone levels.

Roof Upblast/Sidewall Exhaust

Size-180HP: CUBE • CUE • USGF CWB • CW

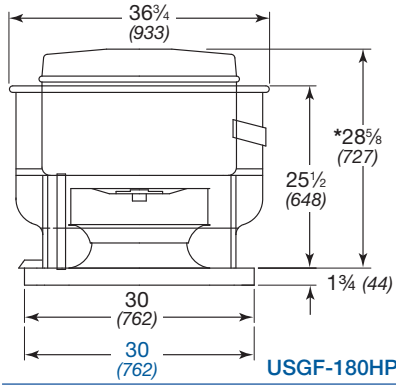

Direct Drive RPM
A-1725 RPM

USGF-180HP • CUBE • CUE
CWB • CW

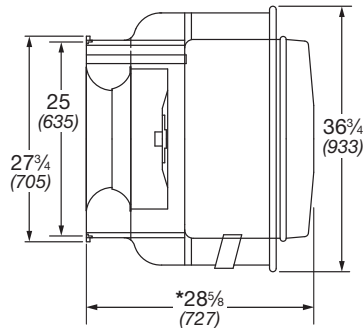

All dimensions in inches (millimeters), weight in pounds (kilograms).
* May be greater depending on motor.
^Weight shown is largest cataloged open drip-proof motor.
Specifications and image for each model located at back of catalog.

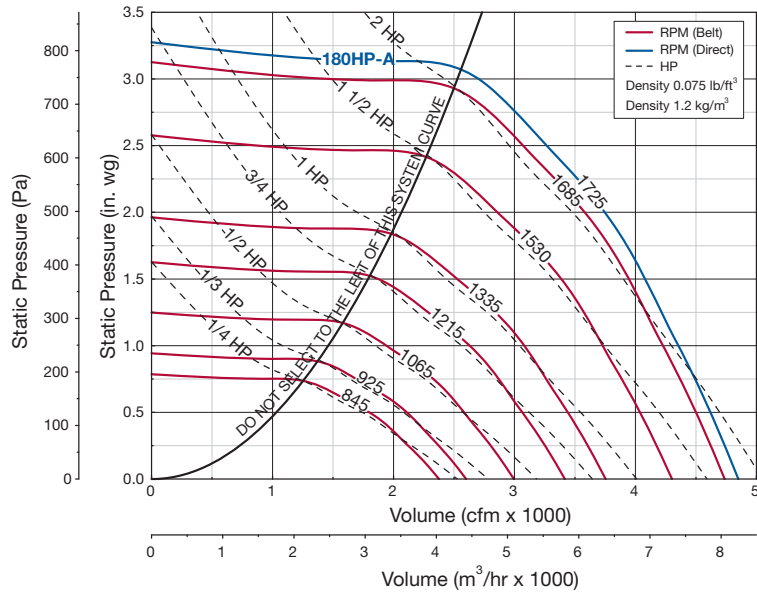

	CUBE	CUE	USGF	CWB	CW
^Approximate Weight	126 (57)	142 (64)	190 (86)	126 (57)	142 (64)
Damper Size	18 x 18 (457 x 457)	N/A	N/A	17 x 17 (432 x 432)	17 x 17 (432 x 432)
Roof/Wall Opening	20 1/2 x 20 1/2 (521 x 521)			17 1/2 x 17 1/2 (445 X 445)	

Motor HP	Fan RPM	Static Pressure in Inches wg										
		0.5	0.75	1	1.25	1.5	1.75	2	2.25	2.5	2.75	
180HP												
1/4	845	CFM	1799									
		BHP	0.26									
		Sones	9.6									
1/3	925	CFM	2104	1688								
		BHP	0.34	0.35								
		Sones	10.8	9.9								
1/2	1065	CFM	2581	2323	1933							
		BHP	0.50	0.52	0.53							
		Sones	14.1	12.6	12.5							
3/4	1215	CFM	3063	2868	2626	2286	1854					
		BHP	0.72	0.76	0.78	0.79	0.75					
		Sones	15.4	14.8	14.2	13.5	12.7					
1	1275	CFM	3253	3066	2853	2566	2209					
		BHP	0.82	0.87	0.89	0.91	0.89					
		Sones	17	16.2	15.6	15.1	14.3					
	1335	CFM	3441	3261	3075	2839	2523	2156				
		BHP	0.93	0.98	1.02	1.04	1.04	1.01				
		Sones	19	17.8	17.3	16.8	16.3	15.7				
1 1/2	1430	CFM	3735	3566	3401	3206	2964	2669	2320			
		BHP	1.13	1.19	1.23	1.26	1.27	1.28	1.24			
		Sones	22	21	20	19.6	19.2	18.8	18.2			
	1530	CFM	4035	3884	3728	3574	3376	3135	2859	2534		
		BHP	1.36	1.43	1.48	1.53	1.55	1.56	1.57	1.53		
		Sones	24	23	22	21	21	20	19.7	19.1		
2	1610	CFM	4273	4136	3986	3840	3674	3485	3233	2965	2656	1557
		BHP	1.58	1.64	1.70	1.76	1.79	1.81	1.82	1.82	1.78	1.38
		Sones	26	24	24	23	22	22	21	20	19.8	18.3
	1685	CFM	4495	4369	4226	4085	3945	3768	3575	3325	3061	2766
		BHP	1.79	1.86	1.93	1.99	2.04	2.07	2.08	2.09	2.08	2.04
		Sones	28	27	26	26	25	23	22	22	21	21
A-2	1725	CFM	4613	4493	4353	4215	4078	3917	3740	3509	3265	2984
		BHP	1.92	1.99	2.06	2.12	2.18	2.21	2.23	2.24	2.25	2.21
		Sones	29	28	27	29	27	25	24	23	22	21

MAXIMUM BHP AT A GIVEN RPM = (RPM/1315)³
MAXIMUM RPM = 1725
TIP SPEED (ft/min) = RPM x 4.843
MAXIMUM MOTOR FRAME SIZE = 184T
AVERAGE DISCHARGE VELOCITY (FPM) = CFM/2.92

Performance certified is for installation type A: Free inlet, Free outlet. Power rating (Bhp) does not include transmission losses. Performance ratings do not include the effects of appurtenances (accessories). The sound ratings shown are loudness values in fan sones at 5 ft. (1.5 m) in a hemispherical free field calculated per AMCA Standard 301. Values shown are for installation type A: Free inlet hemispherical sone levels.

Roof Upblast/Sidewall Exhaust Size-200: CUBE • CUE • USGF CWB • CW

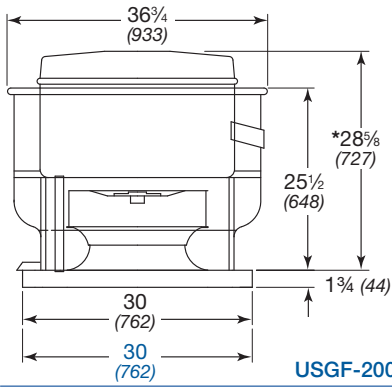

Direct Drive RPM

C-860 RPM
B-1140 RPM

USGF-200 • CUBE • CUE

CWB • CW

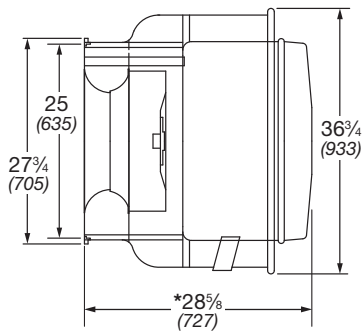

All dimensions in inches (millimeters), weight in pounds (kilograms).
 * May be greater depending on motor.
 ^ Weight shown is largest cataloged open drip-proof motor.
 Specifications and image for each model located at back of catalog.

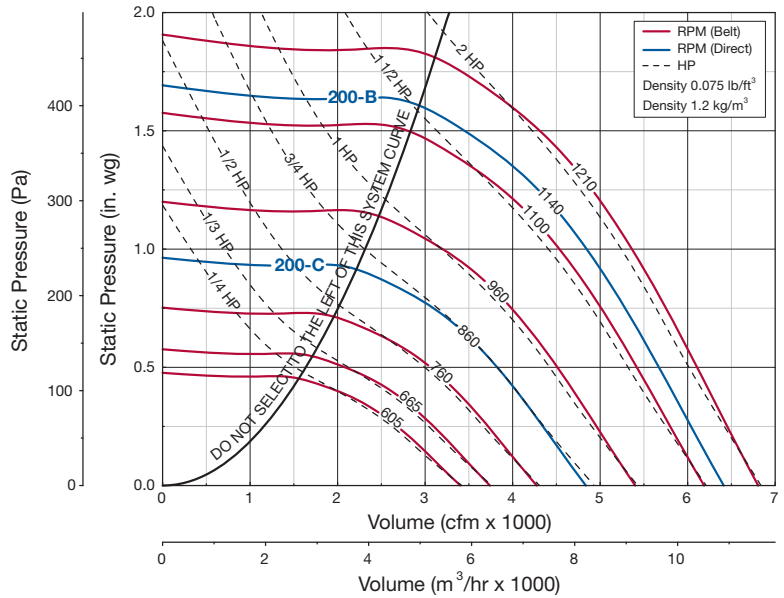

	CUBE	CUE	USGF	CWB	CW
^Approximate Weight	142 (64)	170 (77)	213 (97)	142 (64)	142 (64)
Damper Size	18 x 18 (457 x 457)	N/A	N/A	17 x 17 (432 x 432)	17 x 17 (432 x 432)
Roof/Wall Opening	20 1/2 x 20 1/2 (521 x 521)		17 1/2 x 17 1/2 (445 X 445)		

Motor HP	Fan RPM	CFM	Static Pressure in Inches wg									
			0	0.125	0.25	0.375	0.5	0.75	1	1.25	1.5	1.75
200												
1/4	605	CFM	3403	3054	2675	2144						
		BHP	0.25	0.26	0.26	0.25						
		Sones	8.2	7.6	6.8	6.2						
1/3	665	CFM	3740	3422	3096	2699	2073					
		BHP	0.33	0.34	0.35	0.35	0.33					
		Sones	9.6	9	8.3	7.5	7.2					
1/2	760	CFM	4275	3994	3718	3413	3048					
		BHP	0.49	0.51	0.52	0.52	0.51					
		Sones	12.3	11.8	11.1	10.2	9.5					
3/4	C-3/4	820	CFM	4612	4350	4098	3828	3523	2606			
			BHP	0.61	0.63	0.65	0.65	0.65	0.61			
			Sones	14.2	14.1	13.3	12.5	11.5	10.9			
	860	CFM	4837	4587	4346	4093	3815	3084				
		BHP	0.71	0.73	0.74	0.75	0.75	0.73				
		Sones	15.8	15.7	14.9	14.4	13	12				
875	CFM	4922	4676	4439	4192	3922	3240					
	BHP	0.75	0.77	0.78	0.79	0.79	0.78					
	Sones	16.4	16.4	15.6	15.1	13.7	12.6					
1	960	CFM	5400	5176	4958	4742	4508	3985	3169			
		BHP	0.98	1.01	1.03	1.04	1.04	1.04	1.00			
		Sones	18.9	18.6	18	17.4	16.7	15.2	14.7			
1 1/2	1030	CFM	5793	5585	5380	5179	4968	4503	3917	2972		
		BHP	1.22	1.24	1.26	1.28	1.29	1.29	1.27	1.18		
		Sones	21	21	20	19.7	19.2	17.8	16.6	17.1		
	1100	CFM	6187	5992	5798	5610	5421	5006	4529	3861		
		BHP	1.48	1.51	1.53	1.55	1.57	1.57	1.57	1.53		
		Sones	24	23	23	22	22	21	19.7	18.9		
2	B-2	1140	CFM	6412	6224	6036	5855	5674	5283	4837	4276	3445
			BHP	1.65	1.67	1.7	1.72	1.74	1.74	1.74	1.73	1.63
			Sones	25	24	24	23	22	22	21	19.6	20
	1210	CFM	6806	6628	6451	6279	6108	5748	5350	4892	4289	3365
		BHP	1.97	2	2.03	2.05	2.07	2.09	2.09	2.08	2.04	1.88
		Sones	24	24	23	23	23	22	21	20	20	21

MAXIMUM BHP AT A GIVEN RPM = (RPM/946)³
 MAXIMUM RPM = 1210
 TIP SPEED (ft/min) = RPM x 5.595
 MAXIMUM MOTOR FRAME SIZE = 184T
 AVERAGE DISCHARGE VELOCITY (FPM) = CFM/2.92

Performance certified is for installation type A: Free inlet, Free outlet. Power rating (Bhp) does not include transmission losses. Performance ratings do not include the effects of appurtenances (accessories). The sound ratings shown are loudness values in fan sones at 5 ft. (1.5 m) in a hemispherical free field calculated per AMCA Standard 301. Values shown are for installation type A: Free inlet hemispherical sone levels.

Roof Upblast/Sidewall Exhaust

Size-200HP: CUBE • CUE • USGF CWB

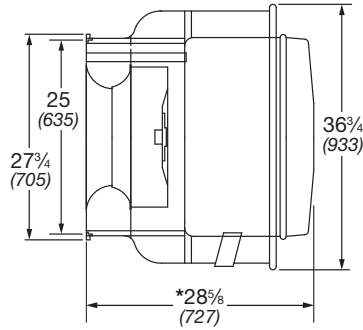
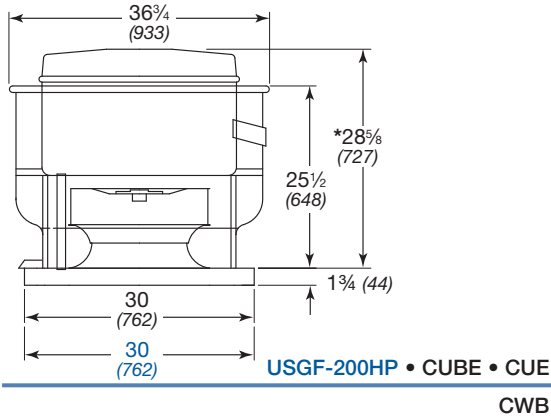

All dimensions in inches (millimeters), weight in pounds (kilograms).
 * May be greater depending on motor.
 ^ Weight shown is largest cataloged open drip-proof motor.
 Specifications and image for each model located at back of catalog.

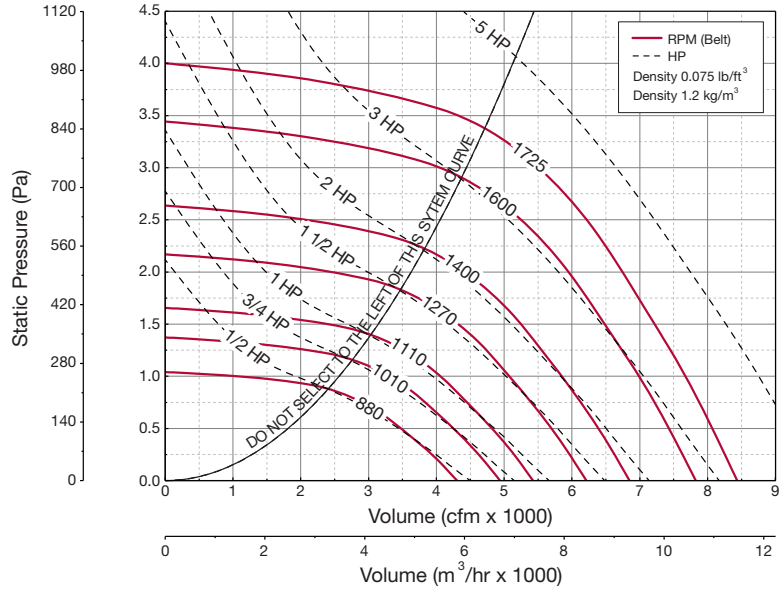

	CUBE	CUE	USGF	CWB
^Approximate Weight	142 (64)	145 (66)	213 (97)	142 (64)
Damper Size	18 x 18 (457 x 457)	N/A	N/A	17 x 17 (432 x 432)
Roof/Wall Opening	20 1/2 x 20 1/2 (521 x 521)		17 1/2 x 17 1/2 (445 X 445)	

Motor HP	Fan RPM	Static Pressure in Inches wg										
		0.5	0.75	1	1.25	1.5	1.75	2	2.25	2.5	2.75	
200HP												
CUBE • CWB • USGF	1/2	CFM	2024									
		BHP	0.31									
		Sones	8.2									
		CFM	2779	2317								
		BHP	0.51	0.52								
		Sones	10.7	9.6								
	3/4	CFM	3094	2711	2092							
		BHP	0.62	0.64	0.62							
		Sones	12.3	11.7	10.8							
		CFM	3397	3067	2637							
		BHP	0.75	0.78	0.79							
		Sones	14.7	14.1	13.5							
1	CFM	3851	3561	3242	2806							
	BHP	0.98	1.02	1.04	1.04							
	Sones	17.1	16.5	16	15.8							
	CFM	4207	3944	3661	3321	2850						
	BHP	1.2	1.24	1.27	1.29	1.26						
	Sones	19.4	18.5	17.9	17.5	17.9						
1 1/2	CFM	4558	4312	4055	3789	3433	2944					
	BHP	1.44	1.49	1.53	1.56	1.56	1.53					
	Sones	22	21	21	20	19.3	20					
	CFM	4837	4606	4369	4116	3826	3482	2946				
	BHP	1.67	1.71	1.76	1.79	1.82	1.82	1.75				
	Sones	23	23	22	21	21	21	22				
2	CFM	5110	4898	4674	4436	4195	3880	3515	2982			
	BHP	1.91	1.96	2.01	2.05	2.09	2.09	2.08	2.01			
	Sones	25	24	24	23	22	23	23	24			
	CFM	5943	5775	5581	5385	5182	4971	4760	4476	4189	3760	
	BHP	2.81	2.88	2.93	2.99	3.03	3.08	3.13	3.13	3.13	3.06	
	Sones	29	27	28	28	28	26	26	28	30	31	
CUE	5	CFM	6457	6302	6135	5954	5772	5582	5386	5190	4948	4682
		BHP	3.50	3.57	3.64	3.69	3.75	3.80	3.85	3.90	3.92	3.92
		Sones	33	30	30	31	32	32	30	28	31	35

MAXIMUM BHP AT A GIVEN RPM = (RPM/1093)³
 MAXIMUM RPM = 1725
 TIP SPEED (ft/min) = RPM x 5.595
 MAXIMUM MOTOR FRAME SIZE = 184T
 AVERAGE DISCHARGE VELOCITY (FPM) = CFM/2.92

Performance certified is for installation type A: Free inlet, Free outlet. Power rating (Bhp) does not include transmission losses. Performance ratings do not include the effects of appurtenances (accessories). The sound ratings shown are loudness values in fan sones at 5 ft. (1.5 m) in a hemispherical free field calculated per AMCA Standard 301. Values shown are for installation type A: Free inlet hemispherical sone levels.

Roof Upblast/Sidewall Exhaust

Size-220: CUBE

CWB

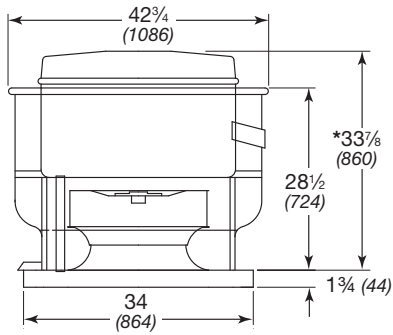

CUBE
CWB

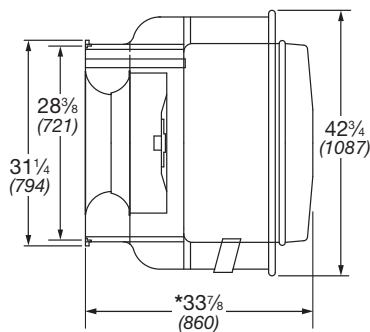

All dimensions in inches (millimeters), weight in pounds (kilograms).
 * May be greater depending on motor.
 ^ Weight shown is largest cataloged open drip-proof motor.
 Specifications and image for each model located at back of catalog.

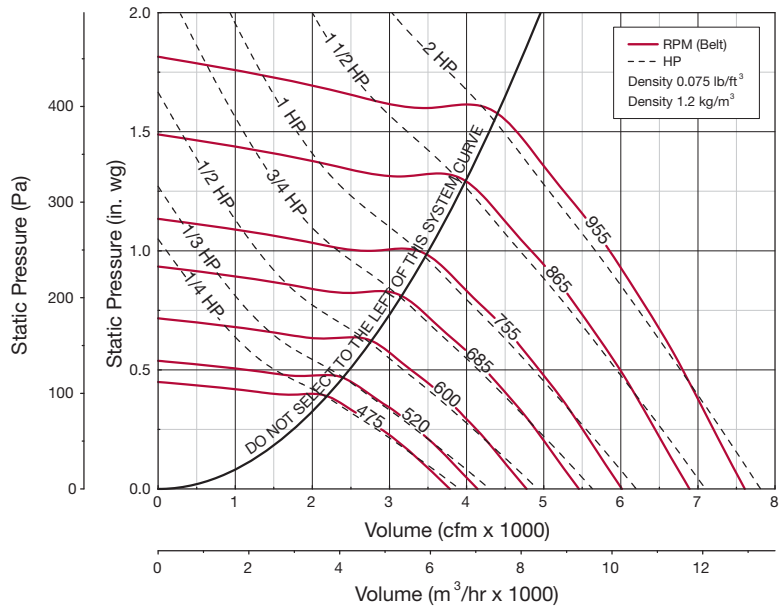

	CUBE	CWB
^Approximate Weight	174 (79)	174 (79)
Damper Size	24 x 24 (610 x 610)	20 x 20 (508 x 508)
Roof/Wall Opening	26 1/2 x 26 1/2 (673 x 673)	20 1/2 x 20 1/2 (521 X 521)

Motor HP	Fan RPM	Static Pressure in Inches wg										
		0	0.125	0.25	0.375	0.5	0.625	0.75	1	1.25	1.5	
220												
1/4	450	CFM	3585	3155	2624							
		BHP	0.19	0.21	0.22							
	475	Sones	7.4	6.8	6.2							
		CFM	3784	3377	2896	2268						
1/3	520	BHP	0.23	0.25	0.26	0.25						
		Sones	8	7.3	6.7	6.2						
	600	CFM	4142	3771	3357	2845						
		BHP	0.3	0.32	0.34	0.34						
1/2	645	Sones	9.3	8.5	7.7	7.2						
		CFM	4779	4457	4124	3736	3279					
	685	BHP	0.46	0.48	0.51	0.52	0.52					
		Sones	12	11.1	10.2	9.5	8.9					
3/4	755	CFM	5138	4838	4539	4194	3811	3346				
		BHP	0.57	0.6	0.63	0.64	0.65	0.64				
	810	Sones	13.6	12.7	12	11.3	10.6	10				
		CFM	5457	5174	4893	4581	4234	3836	3383			
1	865	BHP	0.68	0.71	0.74	0.76	0.78	0.78	0.77			
		Sones	15	14.2	13.7	13.2	12.3	11.7	11.2			
	910	CFM	6014	5758	5502	5239	4944	4620	4258			
		BHP	0.91	0.94	0.98	1.01	1.03	1.04	1.04			
1 1/2	955	Sones	17.7	17	16.6	16.3	15.8	14.9	14.4			
		CFM	6452	6213	5975	5737	5470	5185	4883	4156		
	990	BHP	1.13	1.16	1.2	1.24	1.26	1.28	1.29	1.27		
		Sones	19	18.5	17.9	17.6	17.2	16.5	15.7	14.8		
2	1035	CFM	6890	6667	6443	6220	5987	5729	5453	4835	4111	
		BHP	1.37	1.41	1.45	1.49	1.52	1.54	1.56	1.57	1.53	
	1070	Sones	21	20	19.6	19.2	18.7	18.1	17.4	16.5	16.1	
		CFM	7249	7036	6823	6612	6400	6158	5909	5365	4704	
2 1/2	1105	BHP	1.6	1.64	1.68	1.72	1.76	1.78	1.81	1.83	1.81	
		Sones	23	22	22	21	21	20	19.3	18.3	17.4	
	1140	CFM	7607	7405	7202	7000	6799	6580	6347	5844	5261	4602
		BHP	1.85	1.89	1.93	1.97	2.02	2.05	2.07	2.11	2.11	2.07
2 3/4	1175	Sones	25	25	24	24	23	23	22	20	19.4	18.9
		CFM	7966	7764	7562	7360	7158	6956	6754	6552	6350	6148

MAXIMUM BHP AT A GIVEN RPM = (RPM/743)³
 MAXIMUM RPM = 955
 TIP SPEED (ft/min) = RPM x 6.413
 MAXIMUM MOTOR FRAME SIZE = 184T
 AVERAGE DISCHARGE VELOCITY (FPM) = CFM/3.76

Performance certified is for installation type A: Free inlet, Free outlet. Power rating (Bhp) does not include transmission losses. Performance ratings do not include the effects of appurtenances (accessories). The sound ratings shown are loudness values in fan sones at 5 ft. (1.5 m) in a hemispherical free field calculated per AMCA Standard 301. Values shown are for installation type A: Free inlet hemispherical sone levels.

Roof Upblast/Sidewall Exhaust

Size-220HP: CUBE

CWB

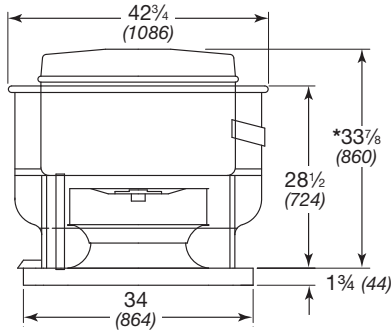

CUBE
CWB

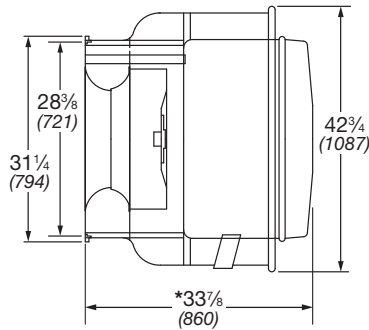

All dimensions in inches (millimeters), weight in pounds (kilograms).
 * May be greater depending on motor.
 ^ Weight shown is largest cataloged open drip-proof motor.
 Specifications and image for each model located at back of catalog.

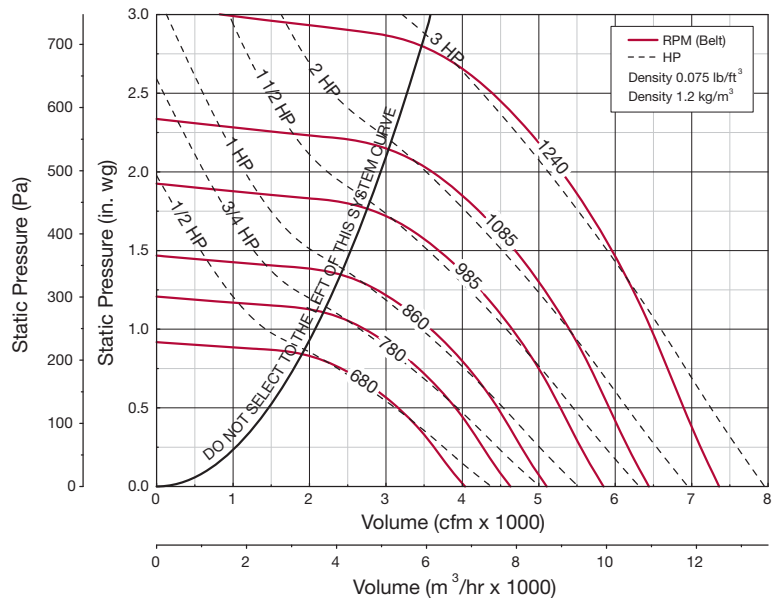

	CUBE	CWB
^Approximate Weight	174 (79)	174 (79)
Damper Size	24 x 24 (610 x 610)	20 x 20 (508 x 508)
Roof/Wall Opening	26 1/2 x 26 1/2 (673 x 673)	20 1/2 x 20 1/2 (521 X 521)

Motor HP	Fan RPM	Static Pressure in Inches wg										
		0.5	0.75	1	1.25	1.5	1.75	2	2.25	2.5	2.75	
220HP												
CUBE • CWB	1/2	CFM	2909	1940								
		BHP	0.45	0.42								
		Sones	8.7	7.7								
		CFM	3151	2405								
		BHP	0.51	0.51								
		Sones	9.7	8.7								
	3/4	CFM	3582	3006								
		BHP	0.63	0.65								
		Sones	11.9	11								
		CFM	3902	3427	2716							
		BHP	0.74	0.78	0.77							
		Sones	13.4	12.5	12.1							
1	CFM	4459	4075	3578	2863							
	BHP	0.96	1.02	1.05	1.01							
	Sones	15	14.3	13.9	13.2							
	CFM	5281	4988	4642	4220	3674	2825					
	BHP	1.39	1.48	1.54	1.57	1.56	1.46					
	Sones	19.1	17.9	17.4	17.1	16.5	14.9					
1 1/2	CFM	5602	5335	5033	4659	4209	3630					
	BHP	1.6	1.69	1.77	1.81	1.82	1.79					
	Sones	21	19.8	18.9	18.7	18.3	17.3					
	CFM	5920	5678	5390	5061	4679	4210	3573				
	BHP	1.82	1.92	2	2.06	2.1	2.09	2.03				
	Sones	23	22	20	20	20	19.6	18.1				
2	CFM	6236	6006	5743	5456	5114	4708	4215	3518			
	BHP	2.06	2.17	2.26	2.34	2.39	2.4	2.38	2.28			
	Sones	24	23	22	22	21	21	21	19.5			
	CFM	6570	6350	6111	5848	5540	5202	4792	4286	3563		
	BHP	2.34	2.46	2.56	2.65	2.71	2.75	2.76	2.72	2.59		
	Sones	25	25	24	24	23	23	22	22	22		
3	CFM	6895	6684	6469	6217	5950	5637	5283	4885	4374	3633	
	BHP	2.64	2.76	2.88	2.97	3.05	3.1	3.13	3.13	3.08	2.92	
	Sones	27	26	26	25	25	24	24	24	24	26	

MAXIMUM BHP AT A GIVEN RPM = (RPM/847)³
 MAXIMUM RPM = 1240
 TIP SPEED (ft/min) = RPM x 6.413
 MAXIMUM MOTOR FRAME SIZE = 184T
 AVERAGE DISCHARGE VELOCITY (FPM) = CFM/3.76

Performance certified is for installation type A: Free inlet, Free outlet. Power rating (Bhp) does not include transmission losses. Performance ratings do not include the effects of appurtenances (accessories). The sound ratings shown are loudness values in fan sones at 5 ft. (1.5 m) in a hemispherical free field calculated per AMCA Standard 301. Values shown are for installation type A: Free inlet hemispherical sone levels.

Roof Upblast/Sidewall Exhaust

Size-240: CUBE • CUE

CWB

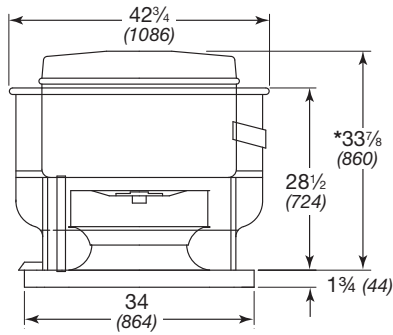

CUBE • CUE
CWB

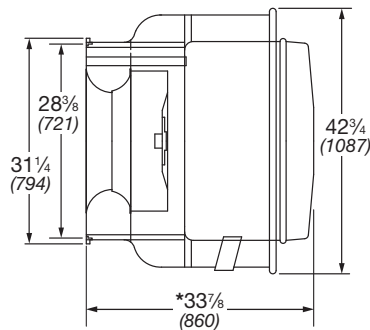

All dimensions in inches (millimeters), weight in pounds (kilograms).
 * May be greater depending on motor.
 ^ Weight shown is largest cataloged open drip-proof motor.
 Specifications and image for each model located at back of catalog.

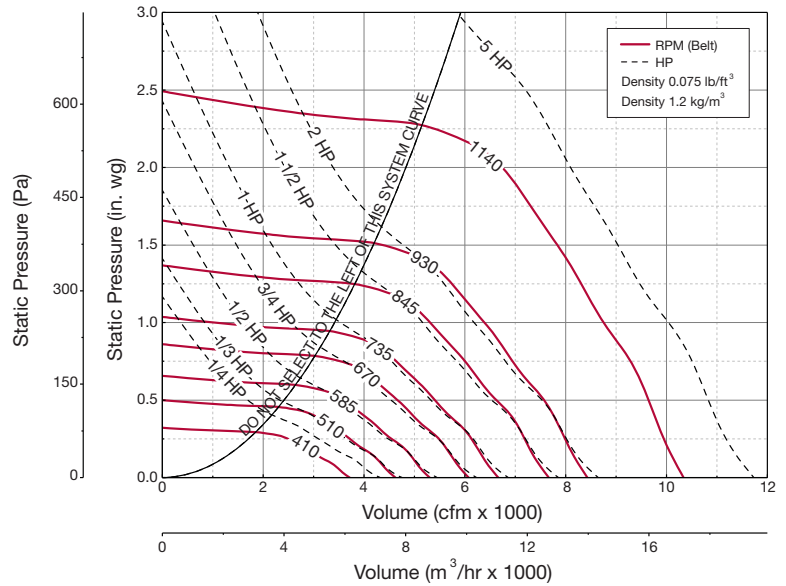

	CUBE	CUE	CWB
^Approximate Weight	142 (64)	226 (103)	175 (79)
Damper Size	24 x 24 (610 x 610)		
Roof/Wall Opening	26½ x 26½ (673 x 673)		26½ x 26½ (673 X 673)

	Motor HP	Fan RPM	Static Pressure in Inches wg													
			0	0.125	0.25	0.375	0.5	0.625	0.75	1	1.25	1.5				
240																
CUBE • CWB	1/4	410	CFM	3717	3170	2471										MAXIMUM BHP AT A GIVEN RPM = (RPM/725) ³ MAXIMUM RPM = 1140 TIP SPEED (ft/min) = RPM x 6.413 MAXIMUM MOTOR FRAME SIZE = 184T AVERAGE DISCHARGE VELOCITY (FPM) = CFM/3.76
			BHP	0.16	0.18	0.18										
			Sones	6.4	5.8	5.3										
	1/3	510	CFM	4623	4243	3717	3134									
			BHP	0.31	0.33	0.34	0.34									
			Sones	8.9	8.1	7.3	6.9									
	1/2	585	CFM	5303	4961	4540	4093	3565								
			BHP	0.46	0.49	0.51	0.52	0.51								
			Sones	11.5	10.5	9.5	8.8	8.4								
	3/4	628	CFM	5693	5368	5010	4590	4141	3600							
			BHP	0.57	0.61	0.63	0.64	0.65	0.63							
			Sones	12.9	11.9	11.1	10.4	9.8	9.4							
670		CFM	6074	5763	5461	5052	4659	4202	3524							
		BHP	0.69	0.74	0.76	0.78	0.79	0.78	0.73							
		Sones	14.3	13.4	12.8	12.2	11.5	11.0	10.6							
1	735	CFM	6663	6370	6133	5764	5409	5037	4618							
		BHP	0.92	0.97	0.99	1.01	1.03	1.04	1.03							
		Sones	16.6	15.9	15.5	15.1	14.6	13.9	13.4							
1½	790	CFM	7162	6883	6661	6361	6011	5693	5332	4453						
		BHP	1.14	1.20	1.22	1.25	1.27	1.28	1.29	1.24						
		Sones	18.2	17.5	17.2	16.8	16.3	15.7	15.0	14.3						
	845	CFM	7660	7400	7184	6947	6615	6304	6002	5282						
		BHP	1.39	1.46	1.49	1.51	1.54	1.56	1.57	1.56						
		Sones	19.6	19.0	18.6	18.2	17.6	17.0	16.4	15.4						
CUBE	CUE	CWB	2	860	CFM	7796	7540	7326	7106	6779	6468	6176	5483	4363		
					BHP	1.47	1.54	1.57	1.59	1.62	1.64	1.66	1.65	1.52		
					Sones	20	19.8	19.4	19.0	18.4	17.8	17.2	16.2	15.9		
CUBE	CWB	2	930	CFM	8431	8194	7985	7798	7536	7233	6953	6375	5706	4324		
				BHP	1.86	1.93	1.98	2.00	2.03	2.06	2.08	2.10	2.07	1.83		
				Sones	24	23	23	22	22	21	19.9	18.7	17.8	17.9		
CUE	5	1140	CFM	10335	10142	9948	9789	9637	9484	9240	8747	8306	7820			
			BHP	3.42	3.51	3.60	3.64	3.67	3.70	3.74	3.81	3.85	3.87			
			Sones	40	40	40	41	40	39	37	33	30	29			

Performance certified is for installation type A: Free inlet, Free outlet. Power rating (Bhp) does not include transmission losses. Performance ratings do not include the effects of appurtenances (accessories). The sound ratings shown are loudness values in fan sones at 5 ft. (1.5 m) in a hemispherical free field calculated per AMCA Standard 301. Values shown are for installation type A: Free inlet hemispherical sone levels.

Roof Upblast/Sidewall Exhaust

Size-240HP: CUBE • CUE

CWB

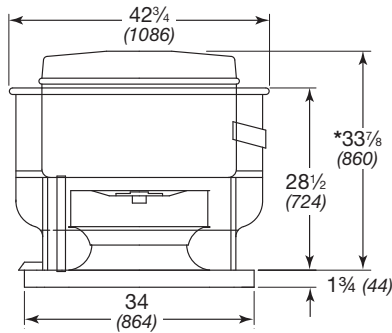

CUBE • CUE
CWB

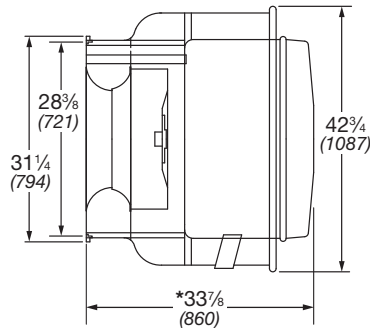

All dimensions in inches (millimeters), weight in pounds (kilograms).
 * May be greater depending on motor.
 ^Weight shown is largest cataloged open drip-proof motor.
 Specifications and image for each model located at back of catalog.

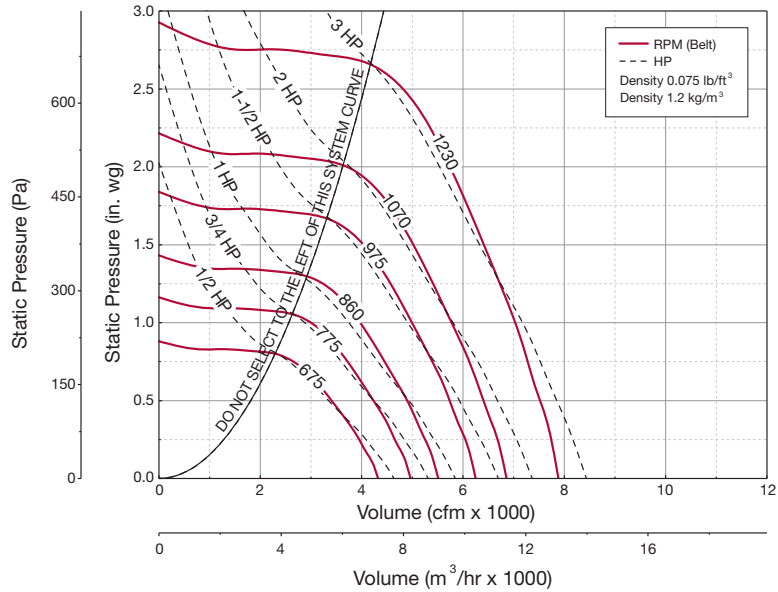

	CUBE	CUE	CWB
^Approximate Weight	175 (79)	209 (95)	175 (79)
Damper Size	24 x 24 (610 x 610)		20 x 20 (508 x 508)
Roof/Wall Opening	26 1/2 x 26 1/2 (673 x 673)		20 1/2 x 20 1/2 (521 X 521)

	Motor HP	Fan RPM	Static Pressure in Inches wg										
			0.5	0.625	0.75	1	1.25	1.5	1.75	2	2.25	2.5	
240HP													
CUBE • CWB	1/2	635	CFM	3046	2673								
			BHP	0.43	0.43								
			Sones	8.1	7.4								
		675	CFM	3405	3070	2607							
			BHP	0.51	0.52	0.51							
			Sones	9.4	8.8	8.4							
3/4	725	CFM	3824	3547	3222								
		BHP	0.62	0.64	0.65								
		Sones	11.3	10.7	10.3								
	775	CFM	4233	3979	3704	2940							
		BHP	0.75	0.77	0.78	0.77							
		Sones	13.1	12.5	12.1	11.8							
CUBE CUE CWB	1	860	CFM	4888	4680	4451	3943	3185					
			BHP	0.99	1.02	1.05	1.07	1.05					
			Sones	15.0	14.5	14.3	13.9	13.2					
CUBE • CWB	1 1/2	913	CFM	5286	5094	4890	4448	3932					
			BHP	1.16	1.20	1.23	1.28	1.29					
			Sones	16.4	15.8	15.4	15.2	14.7					
		975	CFM	5737	5567	5387	4988	4539	4006				
			BHP	1.39	1.43	1.48	1.53	1.56	1.56				
			Sones	18.4	17.9	17.3	16.9	16.6	15.9				
2	1023	CFM	6075	5927	5756	5389	4995	4533	3854				
		BHP	1.59	1.63	1.68	1.75	1.80	1.81	1.77				
		Sones	20	19.6	19.0	18.3	18.1	17.7	16.4				
	1070	CFM	6404	6272	6112	5775	5407	4990	4550	3625			
		BHP	1.80	1.84	1.89	1.98	2.04	2.07	2.08	1.95			
		Sones	22	22	21	19.7	19.4	19.4	18.8	16.6			
CUBE CUE	3	1140	CFM	6891	6766	6637	6329	5994	5649	5239	4825	4052	
			BHP	2.16	2.20	2.25	2.35	2.42	2.49	2.50	2.52	2.41	
			Sones	24	24	23	22	22	22	21	21	19.8	
CUBE	3	1230	CFM	7513	7395	7280	7016	6730	6410	6090	5709	5326	4722
			BHP	2.68	2.73	2.77	2.88	2.98	3.05	3.13	3.14	3.16	3.09
			Sones	26	25	25	25	25	24	24	23	23	25

MAXIMUM BHP AT A GIVEN RPM = (RPM/837)³
 MAXIMUM RPM = 1230
 TIP SPEED (ft/min) = RPM x 6.413
 MAXIMUM MOTOR FRAME SIZE = 184T
 AVERAGE DISCHARGE VELOCITY (FPM) = CFM/3.76

Performance certified is for installation type A: Free inlet, Free outlet. Power rating (Bhp) does not include transmission losses. Performance ratings do not include the effects of appurtenances (accessories). The sound ratings shown are loudness values in fan sones at 5 ft. (1.5 m) in a hemispherical free field calculated per AMCA Standard 301. Values shown are for installation type A: Free inlet hemispherical sone levels.

Roof Upblast/Sidewall Exhaust Size-240XP: CUBE

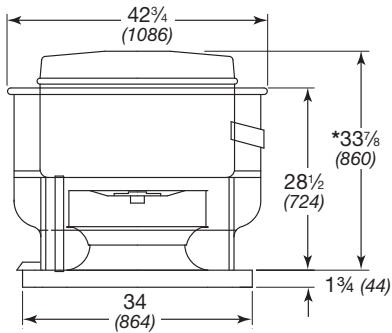

CUBE

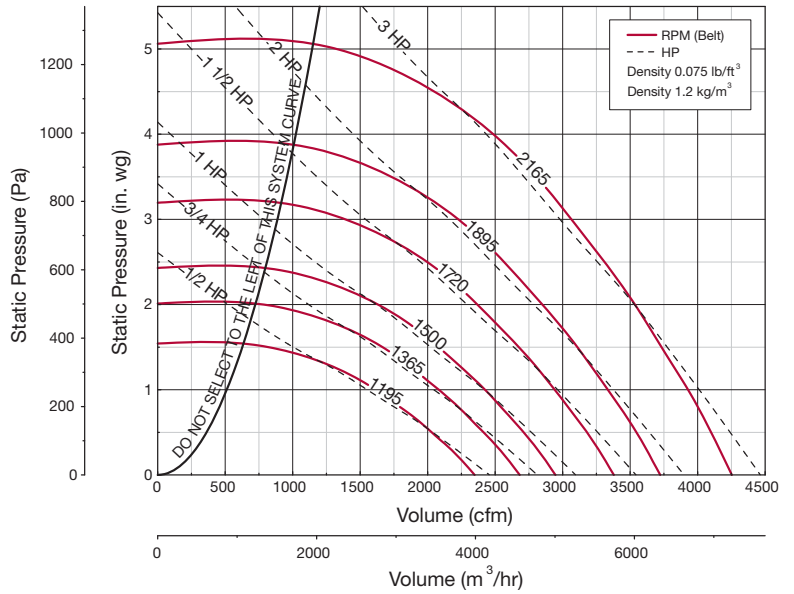

All dimensions in inches (millimeters), weight in pounds (kilograms).

* May be greater depending on motor.

^Weight shown is largest cataloged open drip-proof motor.

Specifications and image for each model located at back of catalog.

	CUBE
^Approximate Weight	175 (79)
Damper Size	24 x 24 (610 x 610)
Roof/Wall Opening	26½ x 26½ (673 x 673)

Motor HP	Fan RPM	Static Pressure in Inches wg										
		1	1.25	1.5	2	2.5	3	3.5	4	4.5	5	
240XP												
1/2	1100	CFM	1292	789								
		BHP	0.40	0.34								
		Sones	10.9	11.9								
	1195	CFM	1613	1321	792							
		BHP	0.53	0.51	0.43							
		Sones	11.6	12.1	13.4							
3/4	1365	CFM	2079	1886	1645							
		BHP	0.77	0.78	0.77							
		Sones	13.6	13.4	13.7							
	1421	CFM	2223	2042	1837	1209						
		BHP	0.86	0.88	0.88	0.79						
		Sones	14.4	14.2	14.2	15.3						
1500	CFM	2424	2256	2079	1630							
	BHP	1.00	1.03	1.04	1.01							
	Sones	15.9	15.3	15.1	15.5							
1 1/2	1635	CFM	2743	2604	2450	2101	1631					
		BHP	1.28	1.31	1.33	1.34	1.28					
		Sones	18.6	18.0	17.5	17.0	17.7					
	1720	CFM	2939	2815	2671	2366	1975	1336				
		BHP	1.48	1.51	1.53	1.57	1.53	1.35				
		Sones	21	19.8	19.2	18.4	18.4	20				
2	1895	CFM	3333	3222	3109	2847	2566	2202	1706			
		BHP	1.94	1.98	2.01	2.07	2.10	2.05	1.92			
		Sones	24	23	22	21	21	21	22			
	1956	CFM	3469	3361	3252	3006	2739	2414	2032	1326		
		BHP	2.13	2.16	2.20	2.26	2.30	2.28	2.21	1.89		
		Sones	25	24	23	22	22	21	22	25		
3	2030	CFM	3632	3529	3423	3197	2945	2667	2319	1852		
		BHP	2.37	2.40	2.44	2.51	2.56	2.58	2.51	2.38		
		Sones	26	25	25	24	23	23	23	25		
	2165	CFM	3927	3830	3733	3535	3305	3063	2787	2461	2048	
		BHP	2.85	2.89	2.93	3.01	3.07	3.12	3.11	3.05	2.93	
		Sones	29	28	28	27	26	25	25	25	27	
										1324	2.47	31

MAXIMUM BHP AT A GIVEN RPM = (RPM/1478)³
 MAXIMUM RPM = 2165
 TIP SPEED (ft/min) = RPM x 4.778
 MAXIMUM MOTOR FRAME SIZE = 184T
 AVERAGE DISCHARGE VELOCITY (FPM) = CFM/3.76

Performance certified is for installation type A: Free inlet, Free outlet. Power rating (Bhp) does not include transmission losses. Performance ratings do not include the effects of appurtenances (accessories). The sound ratings shown are loudness values in fan sones at 5 ft. (1.5 m) in a hemispherical free field calculated per AMCA Standard 301. Values shown are for installation type A: Free inlet hemispherical sone levels.

Roof Upblast/Sidewall Exhaust

Size-300: CUBE • CUE

CWB

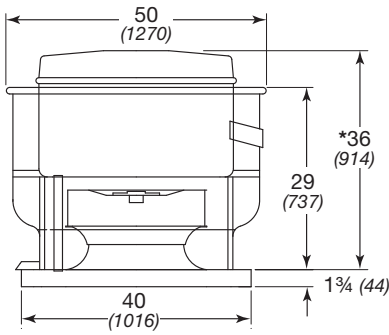

CUBE • CUE
CWB

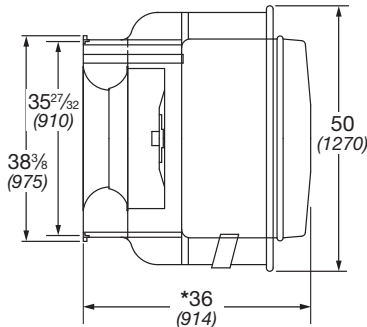

All dimensions in inches (millimeters), weight in pounds (kilograms).
 * May be greater depending on motor.
 ^Weight shown is largest cataloged open drip-proof motor.
 Specifications and image for each model located at back of catalog.

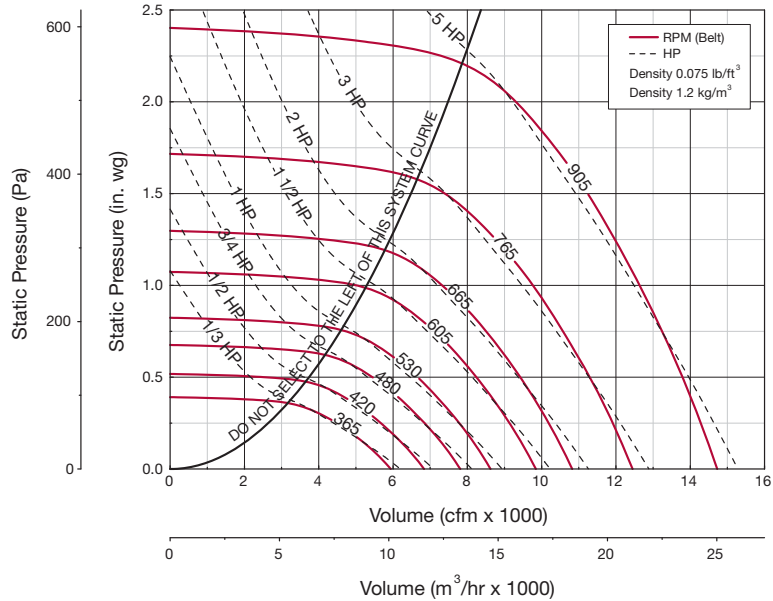

	CUBE	CUE	CWB
^Approximate Weight	313 (142)	380 (172)	313(142)
Damper Size	30 x 30 (762 x 762)		25 x 25 (635 x 635)
Roof/Wall Opening	32½ x 32½ (826 x 826)		25½ x 25½ (648 x 648)

	Motor HP	Fan RPM	Static Pressure in Inches wg										
			0	0.125	0.25	0.5	0.75	1	1.25	1.5	1.75	2	
300													
CUBE • CWB	1/3	355	CFM	5777	5132	4227							
			BHP	0.27	0.30	0.31							
			Sones	6.9	6.3	5.3							
		365	CFM	5940	5316	4464							
			BHP	0.29	0.33	0.34							
			Sones	7.2	6.5	5.7							
	1/2	420	CFM	6835	6314	5660							
			BHP	0.45	0.49	0.52							
			Sones	9.0	8.2	7.5							
	3/4	480	CFM	7811	7377	6844	5440						
			BHP	0.67	0.72	0.76	0.77						
			Sones	11.0	10.5	9.9	8.5						
1	530	CFM	8625	8231	7772	6636							
		BHP	0.90	0.95	1.00	1.05							
		Sones	13.3	12.7	12.2	11.2							
1½	605	CFM	9845	9501	9127	8226	7084						
		BHP	1.34	1.40	1.46	1.54	1.55						
		Sones	17.0	16.4	15.7	14.8	13.5						
2	665	CFM	10822	10508	10193	9411	8495	7271					
		BHP	1.77	1.85	1.92	2.02	2.07	2.04					
		Sones	20	19.7	18.6	17.5	16.7	15.1					
CUBE	3	765	CFM	12449	12176	11904	11273	10554	9743	8756	7352		
			BHP	2.70	2.78	2.86	3.00	3.09	3.15	3.14	2.98		
			Sones	24	24	23	22	21	20	18.7	17		
	5	795	CFM	12937	12675	12413	11818	11145	10404	9479	8302		
			BHP	3.03	3.12	3.20	3.35	3.46	3.53	3.53	3.43		
			Sones	26	25	24	23	22	22	21	18.5		
CUBE CUE	5	860	CFM	13995	13753	13510	12987	12392	11721	11002	10124	9007	
			BHP	3.84	3.93	4.02	4.19	4.33	4.41	4.47	4.46	4.34	
			Sones	30	30	29	27	26	26	24	23	21	
CUBE	5	905	CFM	14727	14497	14266	13788	13223	12614	11963	11191	10357	9178
			BHP	4.47	4.57	4.67	4.85	5.00	5.11	5.19	5.21	5.20	5.01
			Sones	32	32	32	29	28	28	27	26	24	22

MAXIMUM BHP AT A GIVEN RPM = (RPM/522)³
 MAXIMUM RPM = 905
 TIP SPEED (ft/min) = RPM x 7.983
 MAXIMUM MOTOR FRAME SIZE = 213T
 AVERAGE DISCHARGE VELOCITY (FPM) = CFM/5.50

Performance certified is for installation type A: Free inlet, Free outlet. Power rating (Bhp) does not include transmission losses. Performance ratings do not include the effects of appurtenances (accessories). The sound ratings shown are loudness values in fan sones at 5 ft. (1.5 m) in a hemispherical free field calculated per AMCA Standard 301. Values shown are for installation type A: Free inlet hemispherical sone levels.

Roof Upblast/Sidewall Exhaust

Size-300HP: CUBE • CUE

CWB

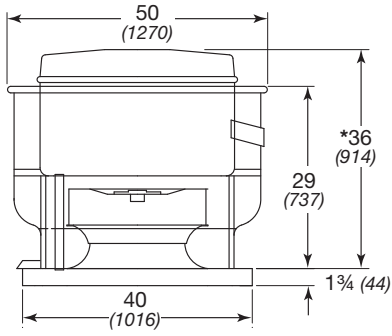

CUBE • CUE
CWB

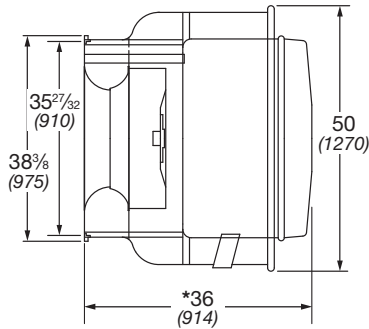

All dimensions in inches (millimeters), weight in pounds (kilograms).
 * May be greater depending on motor.
 ^ Weight shown is largest cataloged open drip-proof motor.
 Specifications and image for each model located at back of catalog.

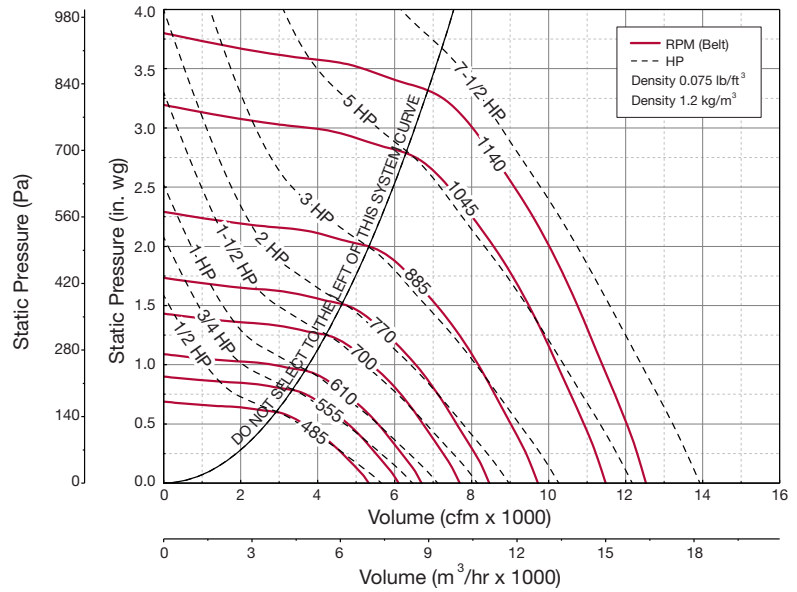

	CUBE	CUE	CWB
^Approximate Weight	313 (142)	434 (197)	313 (142)
Damper Size	30 x 30 (762 x 762)	25 x 25 (635 x 635)	25 x 25 (635 x 635)
Roof/Wall Opening	32 1/2 x 32 1/2 (826 x 826)	25 1/2 x 25 1/2 (648 x 648)	25 1/2 x 25 1/2 (648 x 648)

	Motor HP	Fan RPM	Static Pressure in Inches wg									
			0.5	0.75	1	1.25	1.5	1.75	2	2.25	2.5	2.75
300HP												
CUBE • CWB	1/2	460	CFM 3125									
		485	BHP 0.44									
	3/4	555	Sones 7.3									
		610	CFM 3639									
			BHP 0.52									
1 1/2	700	Sones 7.9										
	770	CFM 4788	3651									
2	770	BHP 0.77	0.76									
		Sones 10.4	9.9									
3	860	CFM 5549	4731									
		BHP 1.00	1.03									
5	991	Sones 12.4	11.3									
		CFM 6741	6149	5390								
7 1/2	1140	BHP 1.47	1.53	1.57								
		Sones 16.0	15.2	14.0								
CUBE	5	1045	CFM 7613	7107	6535	5814	4684					
			BHP 1.91	2.00	2.06	2.09	1.99					
CUE	7 1/2	1140	Sones 18.6	18.1	17.4	16.2	16.0					
			CFM 8712	8289	7812	7292	6647	5834				
CWB	3	885	BHP 2.61	2.72	2.80	2.87	2.90	2.85				
			Sones 22	22	22	21	20	19.9				
CWB	3	885	CFM 9014	8603	8150	7678	7062	6353				
			BHP 2.83	2.94	3.03	3.12	3.15	3.14				
CUBE	5	991	Sones 23	23	23	22	21	21				
			CFM 10275	9913	9546	9133	8711	8201	7641	6946		
CUE	7 1/2	1140	BHP 3.90	4.03	4.16	4.26	4.35	4.41	4.44	4.39		
			Sones 30	29	29	28	28	27	26	25		
CWB	3	885	CFM 10909	10570	10222	9855	9455	9054	8533	8002	7330	
			BHP 4.54	4.68	4.82	4.94	5.04	5.13	5.17	5.21	5.15	4.99
CWB	3	885	Sones 35	34	34	33	32	31	31	30	28	
			CFM 12016	11713	11394	11075	10733	10366	9999	9562	9075	8586
CWB	3	885	BHP 5.83	6.00	6.14	6.29	6.42	6.52	6.63	6.70	6.74	
			Sones 46	47	46	44	42	40	40	40	40	38

MAXIMUM BHP AT A GIVEN RPM = (RPM/602)³
 MAXIMUM RPM = 1140
 TIP SPEED (ft/min) = RPM x 7.983
 MAXIMUM MOTOR FRAME SIZE = 213T
 AVERAGE DISCHARGE VELOCITY (FPM) = CFM/5.50

Performance certified is for installation type A: Free inlet, Free outlet. Power rating (Bhp) does not include transmission losses. Performance ratings do not include the effects of appurtenances (accessories). The sound ratings shown are loudness values in fan sones at 5 ft. (1.5 m) in a hemispherical free field calculated per AMCA Standard 301. Values shown are for installation type A: Free inlet hemispherical sone levels.

Roof Upblast/Sidewall Exhaust Size-300XP: CUBE

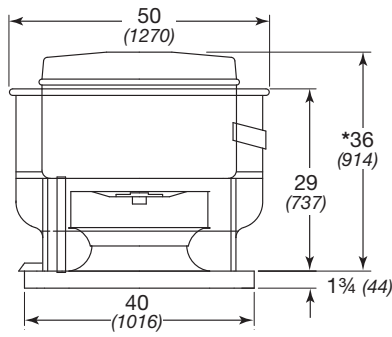

CUBE

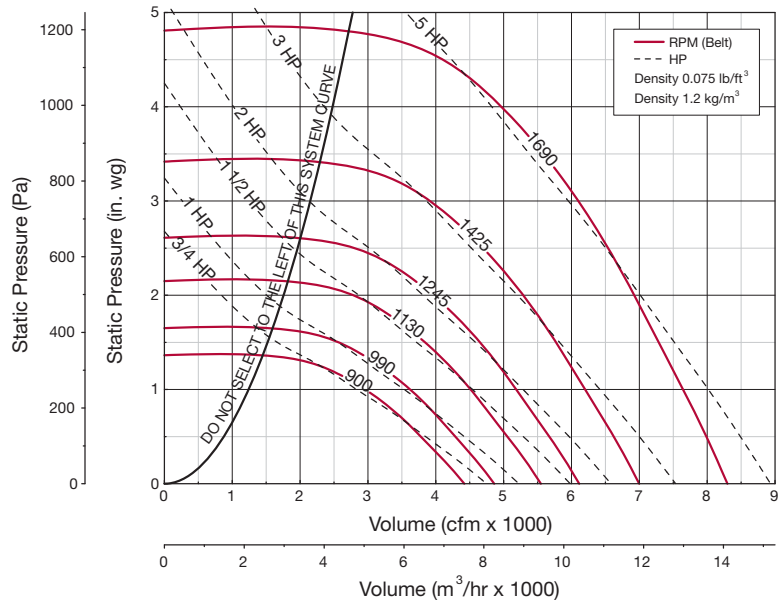

All dimensions in inches (*millimeters*),
weight in pounds (*kilograms*).
* May be greater depending on motor.
^ Weight shown is largest cataloged
open drip-proof motor.
Specifications and image for each model
located at back of catalog.

CUBE	
^Approximate Weight	313 (142)
Damper Size	30 x 30 (762 x 762)
Roof/Wall Opening	32½ x 32½ (826 x 826)

Motor HP	Fan RPM	Static Pressure in Inches wg										
		1	1.25	1.5	2	2.5	3	3.5	4	4.5	4.75	
300XP												
3/4	790	CFM	1776									
		BHP	0.48									
		Sones	9.4									
	900	CFM	2958	2273								
		BHP	0.79	0.75								
		Sones	12.2	11.3								
1	990	CFM	3619	3167	2538							
		BHP	1.04	1.05	1.00							
		Sones	14.6	13.4	12.8							
1½	1060	CFM	4073	3708	3255							
		BHP	1.25	1.28	1.28							
		Sones	16.5	15.3	14.4							
	1130	CFM	4511	4201	3833	2773						
		BHP	1.48	1.53	1.56	1.46						
		Sones	18.9	17.8	16.8	15.6						
2	1245	CFM	5182	4930	4648	3943	2705					
		BHP	1.92	1.99	2.04	2.08	1.86					
		Sones	22	21	20	18.6	17.9					
3	1335	CFM	5695	5465	5220	4648	3905					
		BHP	2.32	2.40	2.47	2.56	2.53					
		Sones	24	24	23	21	19.4					
	1425	CFM	6199	5983	5768	5286	4695	3886				
		BHP	2.78	2.86	2.95	3.07	3.14	3.03				
		Sones	27	26	25	24	22	21				
5	1493	CFM	6574	6369	6164	5722	5200	4550	3646			
		BHP	3.16	3.25	3.34	3.49	3.58	3.57	3.37			
		Sones	29	28	28	26	24	23	22			
	1560	CFM	6941	6746	6549	6143	5684	5134	4441	3049		
		BHP	3.57	3.67	3.76	3.93	4.05	4.12	4.02	3.50		
		Sones	31	30	30	28	27	25	24	24		
	1690	CFM	7643	7464	7284	6920	6528	6091	5587	4951	4100	3070
		BHP	4.47	4.57	4.68	4.87	5.04	5.16	5.24	5.14	4.88	4.32
		Sones	36	35	34	33	31	30	29	28	28	28

MAXIMUM BHP AT A
GIVEN RPM = (RPM/972)³
MAXIMUM RPM = 1690
TIP SPEED (ft/min) = RPM x 5.825
MAXIMUM MOTOR FRAME SIZE = 213T
AVERAGE DISCHARGE VELOCITY
(FPM) = CFM/5.50

Performance certified is for installation type A: Free inlet, Free outlet. Power rating (Bhp) does not include transmission losses. Performance ratings do not include the effects of appurtenances (accessories). The sound ratings shown are loudness values in fan sones at 5 ft. (1.5 m) in a hemispherical free field calculated per AMCA Standard 301. Values shown are for installation type A: Free inlet hemispherical sone levels.

Roof Upblast/Sidewall Exhaust Size-360: CUBE

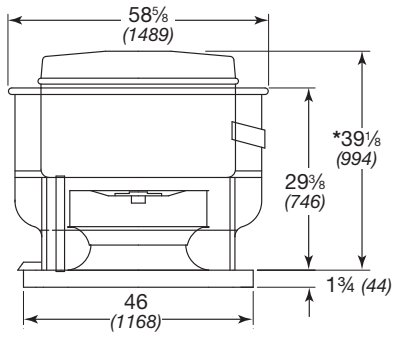

CUBE

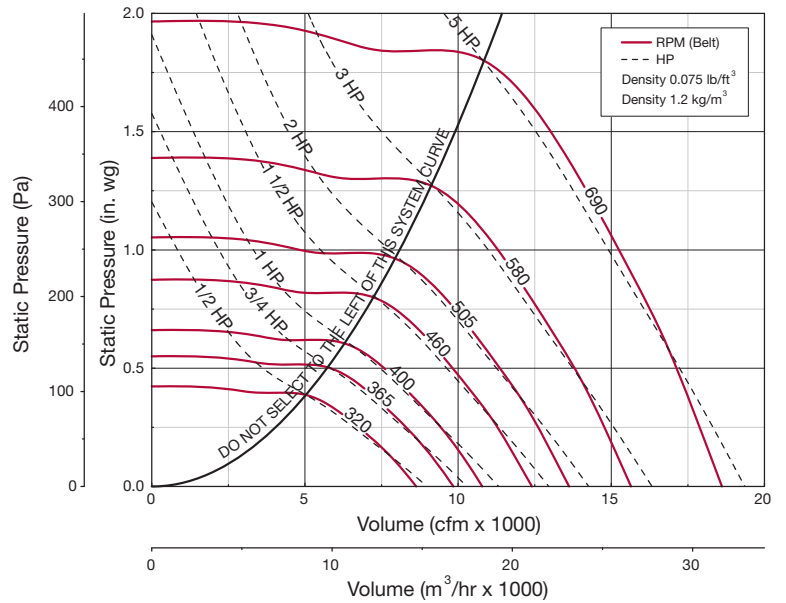

All dimensions in inches (millimeters), weight in pounds (kilograms).
 * May be greater depending on motor.
 ^ Weight shown is largest cataloged open drip-proof motor.
 Specifications and image for each model located at back of catalog.

CUBE	
^Approximate Weight	440 (200)
Damper Size	36 x 36 (914 x 914)
Roof/Wall Opening	38 1/2 x 38 1/2 (978 x 978)

Motor HP	Fan RPM		Static Pressure in Inches wg									
			0	0.125	0.25	0.375	0.5	0.75	1	1.25	1.5	1.75
360												
1/2	300	CFM	8092	7206	6023							
		BHP	0.37	0.42	0.43							
		Sones	6.9	5.9	5.4							
	320	CFM	8631	7820	6755	5256						
		BHP	0.44	0.50	0.52	0.51						
		Sones	7.7	6.8	6.0	6.6						
3/4	365	CFM	9845	9142	8299	7286	5767					
		BHP	0.66	0.72	0.77	0.78	0.74					
		Sones	10.2	9.4	8.5	8.0	8.3					
1	400	CFM	10789	10153	9426	8556	7575					
		BHP	0.87	0.94	0.99	1.02	1.02					
		Sones	12.7	11.9	11.1	10.3	9.9					
1 1/2	460	CFM	12408	11862	11281	10587	9814	7809				
		BHP	1.32	1.40	1.48	1.53	1.55	1.52				
		Sones	16.8	16.5	15.8	15.1	14.5	13.5				
2	505	CFM	13621	13125	12602	12022	11359	9878				
		BHP	1.74	1.83	1.92	1.99	2.04	2.06				
		Sones	20	20	19.8	19.0	18.6	17.9				
3	543	CFM	14646	14184	13705	13209	12606	11302	9606			
		BHP	2.17	2.26	2.36	2.45	2.50	2.56	2.52			
		Sones	22	22	21	21	20	19.3	18.2			
	580	CFM	15644	15212	14769	14306	13783	12597	11287	9381		
		BHP	2.64	2.74	2.84	2.94	3.02	3.10	3.13	3.02		
		Sones	23	23	23	22	22	21	20	18.4		
5	617	CFM	16642	16236	15826	15391	14942	13862	12684	11227		
		BHP	3.18	3.29	3.40	3.50	3.60	3.71	3.76	3.73		
		Sones	25	25	25	24	24	23	22	21		
	654	CFM	17640	17257	16873	16466	16056	15084	14000	12831	11217	
		BHP	3.78	3.90	4.02	4.13	4.24	4.39	4.46	4.48	4.38	
		Sones	27	27	27	26	26	25	23	22	21	
	690	CFM	18611	18248	17884	17504	17115	16236	15243	14187	12985	11290
		BHP	4.44	4.57	4.69	4.81	4.93	5.11	5.21	5.26	5.25	5.09
		Sones	30	29	28	28	28	27	25	24	23	22

MAXIMUM BHP AT A GIVEN RPM = (RPM/396)³
 MAXIMUM RPM = 690
 TIP SPEED (ft/min) = RPM x 9.425
 MAXIMUM MOTOR FRAME SIZE = 213T
 AVERAGE DISCHARGE VELOCITY (FPM) = CFM/7.25

Performance certified is for installation type A: Free inlet, Free outlet. Power rating (Bhp) does not include transmission losses. Performance ratings do not include the effects of appurtenances (accessories). The sound ratings shown are loudness values in fan sones at 5 ft. (1.5 m) in a hemispherical free field calculated per AMCA Standard 301. Values shown are for installation type A: Free inlet hemispherical sone levels.

Roof Upblast/Sidewall Exhaust Size-360HP: CUBE

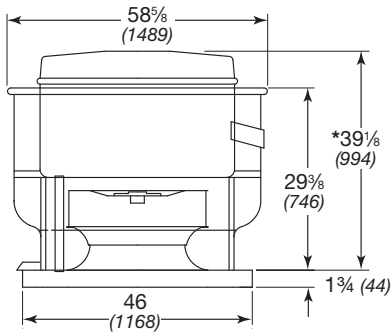

CUBE

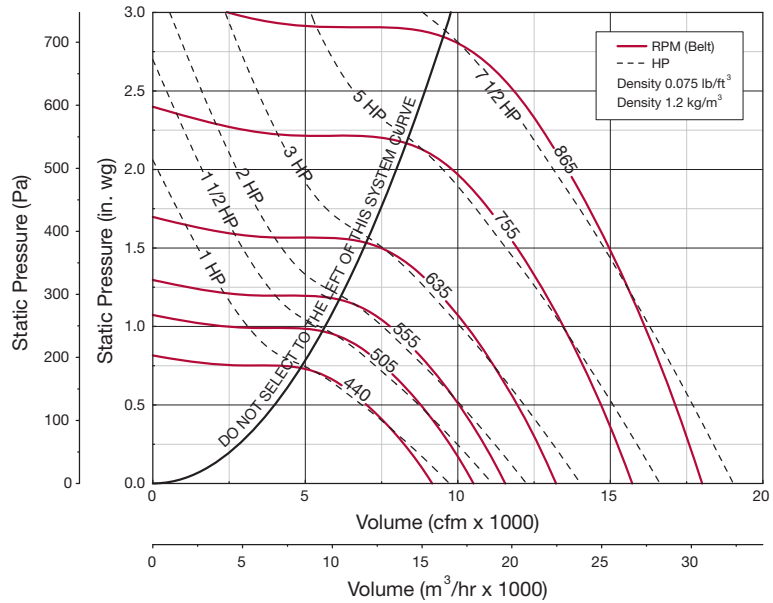

All dimensions in inches (millimeters), weight in pounds (kilograms).
 * May be greater depending on motor.
 ^Weight shown is largest cataloged open drip-proof motor.
 Specifications and image for each model located at back of catalog.

CUBE	
^Approximate Weight	440 (200)
Damper Size	36 x 36 (914 x 914)
Roof/Wall Opening	38 1/2 x 38 1/2 (978 x 978)

Motor HP	Fan RPM	Static Pressure in Inches wg										
		0.5	0.75	1	1.25	1.5	1.75	2	2.25	2.5	2.75	
360HP												
1	420	CFM	6407									
		BHP	0.90									
		Sones	9.6									
	440	CFM	7003									
		BHP	1.03									
		Sones	10.8									
1 1/2	505	CFM	8765	7539								
		BHP	1.52	1.57								
		Sones	15.3	14.3								
	555	CFM	10029	9046	7766							
		BHP	1.97	2.06	2.08							
		Sones	17.2	16.2	15.4							
3	595	CFM	10996	10129	9094	7488						
		BHP	2.40	2.50	2.57	2.49						
		Sones	18.9	17.7	16.8	16.1						
	635	CFM	11934	11157	10276	9171	7329					
		BHP	2.87	3.00	3.09	3.12	2.95					
		Sones	21	19.5	18.2	17.8	17.3					
5	695	CFM	13321	12662	11902	11053	10026	8393				
		BHP	3.70	3.86	3.98	4.07	4.09	3.92				
		Sones	24	23	22	20	20	19.6				
	755	CFM	14688	14086	13434	12734	11922	10973	9593			
		BHP	4.68	4.86	5.01	5.14	5.23	5.24	5.10			
		Sones	28	27	26	25	24	23	22			
7 1/2	781	CFM	15275	14693	14086	13410	12681	11831	10852	9149		
		BHP	5.15	5.34	5.51	5.64	5.75	5.81	5.79	5.51		
		Sones	30	29	28	27	27	26	24	23		
	824	CFM	16232	15689	15137	14511	13869	13127	12290	11354	9683	
		BHP	6.00	6.20	6.40	6.54	6.69	6.78	6.82	6.79	6.48	
		Sones	31	29	27	28	29	28	26	25	24	
	865	CFM	17129	16631	16105	15544	14933	14315	13565	12738	11789	10197
		BHP	6.89	7.11	7.32	7.50	7.64	7.79	7.87	7.89	7.83	7.50
		Sones	33	32	30	29	29	29	28	27	25	23

MAXIMUM BHP AT A GIVEN RPM = (RPM/434)³
 MAXIMUM RPM = 865
 TIP SPEED (ft/min) = RPM x 9.425
 MAXIMUM MOTOR FRAME SIZE = 213T
 AVERAGE DISCHARGE VELOCITY (FPM) = CFM/7.25

Performance certified is for installation type A: Free inlet, Free outlet. Power rating (Bhp) does not include transmission losses. Performance ratings do not include the effects of appurtenances (accessories). The sound ratings shown are loudness values in fan sones at 5 ft. (1.5 m) in a hemispherical free field calculated per AMCA Standard 301. Values shown are for installation type A: Free inlet hemispherical sone levels.

Roof Upblast/Sidewall Exhaust Size-360XP: CUBE

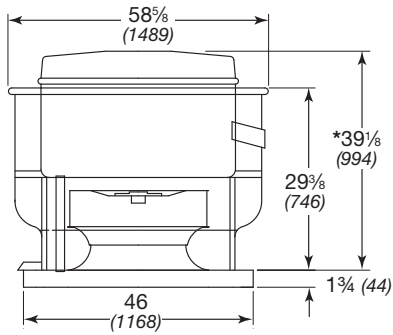

CUBE

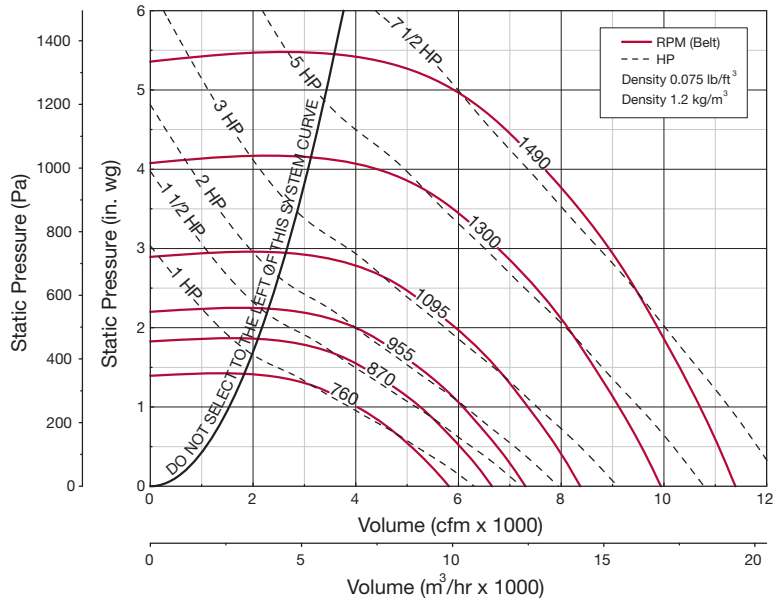

All dimensions in inches (millimeters), weight in pounds (kilograms).
 * May be greater depending on motor.
 ^Weight shown is largest cataloged open drip-proof motor.
 Specifications and image for each model located at back of catalog.

	CUBE
^Approximate Weight	440 (200)
Damper Size	36 x 36 (914 x 914)
Roof/Wall Opening	38 1/2 x 38 1/2 (978 x 978)

Motor HP	Fan RPM	Static Pressure in Inches wg										
		1	1.25	1.5	2	2.5	3	3.5	4	4.5	5	
360XP												
1	700	CFM	3210									
		BHP	0.81									
	Sones	10.5										
	760	CFM	4020	3225								
BHP		1.05	1.01									
Sones		11.1	11.1									
1 1/2	870	CFM	5243	4740	4112							
		BHP	1.53	1.57	1.55							
		Sones	13.6	12.7	12.3							
2	955	CFM	6081	5679	5216	3949						
		BHP	1.97	2.04	2.08	1.98						
		Sones	15.4	15.4	14.2	13.0						
3	1025	CFM	6722	6396	6001	5035	3264					
		BHP	2.38	2.47	2.54	2.55	2.18					
		Sones	17.1	16.5	16.2	14.5	13.4					
	1095	CFM	7351	7050	6724	5930	4905					
		BHP	2.85	2.95	3.03	3.13	3.07					
		Sones	19.2	18.4	17.8	16.4	15.4					
5	1163	CFM	7945	7669	7386	6712	5867	4700				
		BHP	3.36	3.47	3.57	3.73	3.75	3.54				
		Sones	21	21	19.9	18.6	17.3	16.5				
	1231	CFM	8528	8278	8011	7422	6711	5824	4551			
		BHP	3.91	4.05	4.15	4.35	4.45	4.40	4.04			
		Sones	23	23	22	21	19.4	18.5	18.0			
1300	CFM	9113	8881	8635	8125	7502	6764	5867	4286			
	BHP	4.54	4.69	4.82	5.04	5.21	5.24	5.15	4.52			
	Sones	26	25	24	23	22	21	20	20			
7 1/2	1395	CFM	9910	9693	9477	9009	8490	7905	7193	6348	5143	
		BHP	5.50	5.67	5.83	6.08	6.30	6.48	6.48	6.37	5.87	
		Sones	29	28	27	26	25	24	23	23	23	
	1490	CFM	10699	10496	10294	9871	9429	8907	8340	7673	6881	5830
		BHP	6.61	6.78	6.96	7.27	7.52	7.73	7.89	7.90	7.78	7.34
		Sones	33	32	31	30	29	27	26	26	26	27

MAXIMUM BHP AT A GIVEN RPM = (RPM/748)³
 MAXIMUM RPM = 1490
 TIP SPEED (ft/min) = RPM x 7.069
 MAXIMUM MOTOR FRAME SIZE = 213T
 AVERAGE DISCHARGE VELOCITY (FPM) = CFM/7.25

Performance certified is for installation type A: Free inlet, Free outlet. Power rating (Bhp) does not include transmission losses. Performance ratings do not include the effects of appurtenances (accessories). The sound ratings shown are loudness values in fan sones at 5 ft. (1.5 m) in a hemispherical free field calculated per AMCA Standard 301. Values shown are for installation type A: Free inlet hemispherical sone levels.

Roof Upblast/Sidewall Exhaust Size-420: CUBE

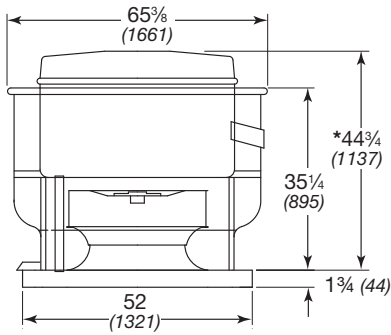

CUBE

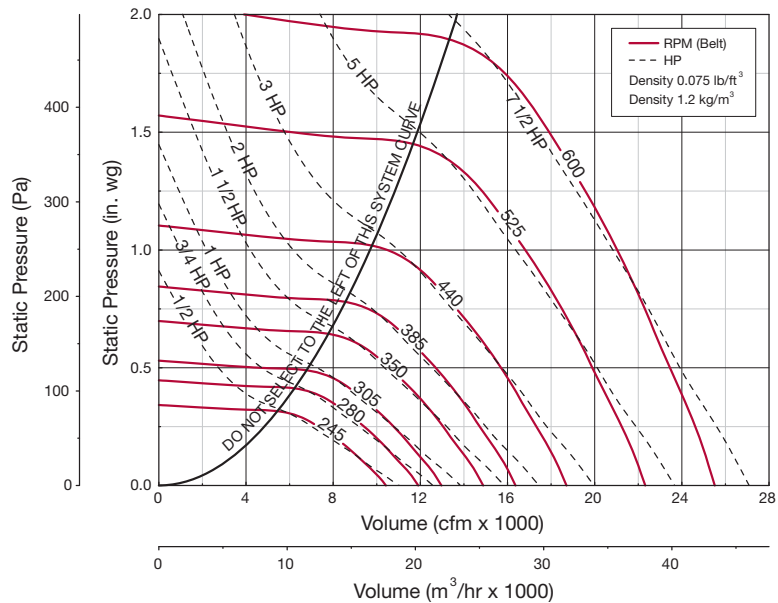

All dimensions in inches (millimeters), weight in pounds (kilograms).
 * May be greater depending on motor.
 ^ Weight shown is largest cataloged open drip-proof motor.
 Specifications and image for each model located at back of catalog.

CUBE	
^Approximate Weight	578 (262)
Damper Size	42 x 42 (1067 x 1067)
Roof/Wall Opening	44½ x 44½ (1130 x 1130)

Motor HP	Fan RPM		Static Pressure in Inches wg									
			0	0.125	0.25	0.375	0.5	0.75	1	1.25	1.5	1.75
420												
1/2	220	CFM	9353	7846	5075							
		BHP	0.31	0.37	0.35							
		Sones	6.5	6.0	5.5							
	245	CFM	10416	9104	7304							
		BHP	0.43	0.50	0.53							
		Sones	7.2	6.7	6.1							
3/4	280	CFM	11904	10785	9418	7419						
		BHP	0.64	0.73	0.78	0.77						
		Sones	8.3	7.7	7.1	6.6						
1	305	CFM	12966	11959	10781	9272						
		BHP	0.82	0.94	1.00	1.02						
		Sones	9.4	8.8	8.0	7.3						
1½	350	CFM	14879	14037	13050	11925	10562					
		BHP	1.24	1.38	1.46	1.52	1.54					
		Sones	11.9	11.2	10.1	9.4	8.6					
2	385	CFM	16367	15629	14731	13791	12701	9246				
		BHP	1.65	1.81	1.91	1.99	2.05	1.92				
		Sones	14.4	13.5	12.4	11.7	10.7	8.5				
3	415	CFM	17643	16982	16148	15303	14363	12028				
		BHP	2.07	2.24	2.37	2.45	2.53	2.56				
		Sones	17.2	16.1	14.9	13.8	13.0	10.9				
	440	CFM	18706	18103	17316	16532	15691	13652	10151			
		BHP	2.47	2.65	2.81	2.89	2.98	3.07	2.82			
		Sones	17.7	17.1	16.0	14.7	14.6	12.8	10.6			
5	525	CFM	22319	21817	21220	20560	19904	18497	16795	14802		
		BHP	4.19	4.41	4.61	4.78	4.88	5.10	5.20	5.16		
		Sones	23	22	22	21	20	19.1	18.1	17.6		
7½	565	CFM	24020	23553	23030	22417	21806	20544	19112	17437	15398	
		BHP	5.23	5.46	5.68	5.88	6.02	6.25	6.43	6.50	6.38	
		Sones	26	25	25	25	24	23	21	21	21	
	600	CFM	25508	25069	24604	24027	23451	22295	21023	19561	17884	15479
		BHP	6.26	6.51	6.75	6.96	7.15	7.38	7.63	7.75	7.77	7.47
		Sones	29	29	29	28	28	27	25	24	24	26

MAXIMUM BHP AT A GIVEN RPM = (RPM/303)³
 MAXIMUM RPM = 600
 TIP SPEED (ft/min) = RPM x 11.06
 MAXIMUM MOTOR FRAME SIZE = 213T
 AVERAGE DISCHARGE VELOCITY (FPM) = CFM/8.99

Performance certified is for installation type A: Free inlet, Free outlet. Power rating (Bhp) does not include transmission losses. Performance ratings do not include the effects of appurtenances (accessories). The sound ratings shown are loudness values in fan sones at 5 ft. (1.5 m) in a hemispherical free field calculated per AMCA Standard 301. Values shown are for installation type A: Free inlet hemispherical sone levels.

Roof Upblast/Sidewall Exhaust Size-480: CUBE

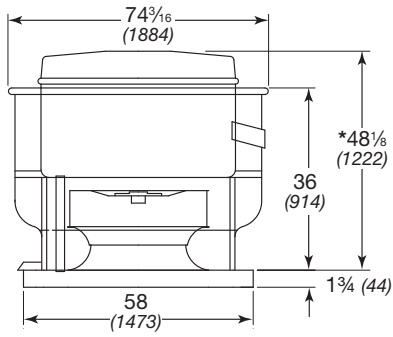

CUBE

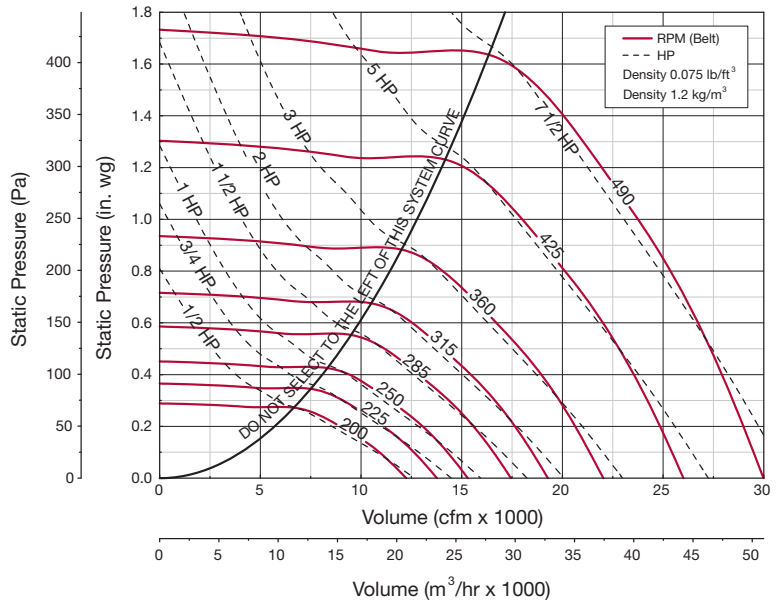

All dimensions in inches (millimeters), weight in pounds (kilograms).
 * May be greater depending on motor.
 ^ Weight shown is largest cataloged open drip-proof motor.
 Specifications and image for each model located at back of catalog.

	CUBE
^Approximate Weight	675 (306)
Damper Size	48 x 48 (1219 x 1219)
Roof/Wall Opening	50½ x 50½ (1283 x 1283)

Motor HP	Fan RPM	Static Pressure in Inches wg										
		0	0.125	0.25	0.375	0.5	0.625	0.75	1	1.25	1.5	
480												
1/2	180	CFM	11016	8924								
		BHP	0.33	0.39								
		Sones	5.5	4.9								
	200	CFM	12240	10490	7688							
		BHP	0.45	0.53	0.52							
		Sones	6.3	5.8	5.3							
3/4	225	CFM	13770	12261	10132							
		BHP	0.65	0.73	0.76							
		Sones	7.5	7.0	6.6							
1	250	CFM	15300	13988	12248	9988						
		BHP	0.89	0.98	1.04	1.03						
		Sones	9.0	8.5	8.2	7.9						
1½	285	CFM	17442	16332	14991	13240	11154					
		BHP	1.31	1.43	1.52	1.55	1.52					
		Sones	11.1	10.6	10.0	9.6	9.2					
2	315	CFM	19278	18274	17116	15719	14033	11996				
		BHP	1.77	1.90	2.01	2.08	2.09	2.03				
		Sones	12.9	12.5	11.8	11.3	10.4	10.2				
3	360	CFM	22032	21153	20222	19142	17848	16410	14749			
		BHP	2.64	2.79	2.93	3.05	3.10	3.12	3.08			
		Sones	16.8	16.5	16.1	15.3	14.7	13.7	12.7			
5	395	CFM	24174	23373	22572	21605	20621	19343	18035	14722		
		BHP	3.49	3.65	3.81	3.94	4.07	4.11	4.13	3.97		
		Sones	21	20	20	19.2	18.5	17.6	16.6	14.9		
	425	CFM	26010	25266	24521	23679	22764	21766	20556	17922		
		BHP	4.35	4.52	4.69	4.85	4.98	5.09	5.12	5.09		
		Sones	22	21	21	20	19.4	18.7	17.7	15.6		
7½	460	CFM	28152	27464	26776	26064	25219	24373	23399	21163	18582	
		BHP	5.51	5.70	5.89	6.07	6.22	6.37	6.46	6.52	6.42	
		Sones	25	24	24	23	22	22	21	18.5	18.7	
	490	CFM	29988	29342	28697	28051	27291	26497	25704	23674	21437	18846
		BHP	6.66	6.86	7.06	7.26	7.43	7.59	7.75	7.85	7.84	7.67
		Sones	28	27	27	26	25	25	24	22	20	24

MAXIMUM BHP AT A GIVEN RPM = (RPM/246)³
 MAXIMUM RPM = 490
 TIP SPEED (ft/min) = RPM x 12.63
 MAXIMUM MOTOR FRAME SIZE = 213T
 AVERAGE DISCHARGE VELOCITY (FPM) = CFM/11.72

Performance certified is for installation type A: Free inlet, Free outlet. Power rating (Bhp) does not include transmission losses. Performance ratings do not include the effects of appurtenances (accessories). The sound ratings shown are loudness values in fan sones at 5 ft. (1.5 m) in a hemispherical free field calculated per AMCA Standard 301. Values shown are for installation type A: Free inlet hemispherical sone levels.

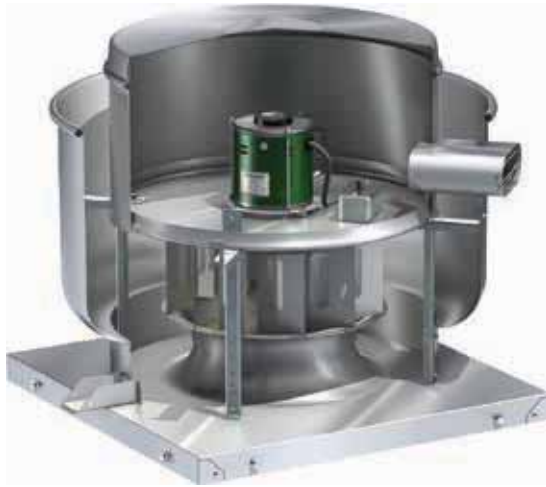

Spun aluminum exhaust fans shall be upblast centrifugal direct drive type. The fan wheel shall be centrifugal backward-inclined, constructed of aluminum and shall include a wheel cone carefully matched to the inlet cone for precise running tolerances. Wheels shall be statically and dynamically balanced. The fan housing shall be constructed of heavy-gauge aluminum with a rigid internal support structure. The windband shall be one-piece and 100% continuously welded to the one-piece aluminum curb cap.

Motors shall be mounted out of the airstream on vibration isolators. Fresh air for motor cooling shall be drawn into the motor compartment through a ten-square-inch tube free of discharge contaminants. Motors and drives shall be readily accessible for maintenance.

A disconnect switch shall be factory-installed and wired from the fan motor to a junction box within the motor compartment. A conduit chase shall be provided through the curb cap to the motor compartment for ease of electrical wiring.

All fans shall bear the AMCA Sound and Air Performance seal.

Each fan shall bear a permanently affixed manufacturer's engraved metal nameplate containing the model number and individual serial number for future identification.

A leakproof fan housing shall be constructed with a one-piece windband with an integral rolled bead for added strength.

Fans shall be model CUE or CUE-HP as manufactured in the USA by Greenheck Fan Corporation headquartered in Schofield, Wisconsin.

Options and Accessories For Direct Drives

UL/cUL Listed

- Fans shall be Listed by Underwriters Laboratory for UL/cUL 705 for all electrical components.
- Fans shall be Listed by Underwriters Laboratory for UL/cUL 762 for all electrical components and grease removal.

Curb Extensions

- Shall be mounted between roof curb and roof mounted fans to meet NFPA requirements of 40-inches (1016 mm) minimum discharge above the roof when mounted on a minimum 8-inch (203 mm) high roof curb.

Grease Containers

- Drain connection shall be constructed of aluminum and allow for single-point drainage of grease, water or other residues.
- Grease trap container shall be constructed from polypropylene. The unit shall collect grease and water from the fan and extract the grease from the water for ease of grease disposal.



Easy Clean Options

- Hinge kit shall be constructed of heavy-gauge aluminum hinges and shall include hold-open mechanism.
- Non-stick wheel shall be constructed of aluminum with a non-stick coating similar to Teflon® as manufactured by DuPont™.
- Clean-Out Port shall have a hole on the outside of the windband and a grease repellent compression rubber fit, allowing access to entire wheel for cleaning.



Windband Extension

- Shall be constructed from heavy-gauge aluminum tube that raises the fan discharge height.

Belt Drive Specifications

Model CUBE



Spun aluminum exhaust fans shall be centrifugal belt-driven type. The fan wheel shall be centrifugal backward-inclined, constructed of aluminum and shall include a wheel cone carefully matched to the inlet cone for precise running tolerances. Wheels shall be statically and dynamically balanced. The fan housing shall be constructed of heavy-gauge aluminum with a rigid internal support structure. The windband shall be one-piece and 100% continuously welded to the one-piece aluminum curb cap, including all sizes with UL/cUL 762.

Motors shall be heavy-duty ball bearing type, carefully matched to the fan load, and furnished at the specified voltage, phase and enclosure. Drive frame assembly shall be constructed of heavy-gauge steel.

Motors and drives shall be mounted on vibration isolators, out of the airstream where no steel-to-steel contact between rotating components and the base shall occur. Fresh air for motor cooling shall be drawn into the motor compartment through a ten-square-inch tube free of discharge contaminants. Motors and drives shall be readily accessible for maintenance.

Precision ground and polished fan shafts shall be mounted in permanently sealed, lubricated pillow block ball bearings. Bearings shall be selected for a minimum L_{10} life in excess of 100,000 hours (L_{50} life of 500,000 hours) at maximum cataloged operating speed. Drives shall be sized for a minimum of 150% of driven horsepower. Pulleys shall be of the cast type, keyed and securely attached to the wheel and motor shafts.

Motor pulleys shall be adjustable for final system balancing. A disconnect switch shall be factory-installed and wired from the fan motor to a junction box installed within the motor compartment. A conduit chase shall be provided through the base to the motor compartment for ease of electrical wiring.

All fans shall bear the AMCA Sound and Air Performance seal.

Each fan shall bear a permanently affixed manufacturer's engraved metal nameplate containing the model number and individual serial number for future identification.

A leakproof fan housing shall be constructed with a one-piece windband with an integral rolled bead for added strength and shall be joined to the curb cap with a continuously welded seam.

Fans shall be model CUBE, CUBE-HP or CUBE-XP as manufactured in the USA by Greenheck Fan Corporation headquartered in Schofield, Wisconsin.

Options and Accessories For Belt Drives

UL/cUL Listed

- Fans shall be Listed by Underwriters Laboratory for UL/cUL 705 for all electrical components.
- Fans shall be Listed by Underwriters Laboratory for UL/cUL 762 for all electrical components and grease removal.

Curb Extensions

- Shall be mounted between roof curb and roof mounted fans to meet NFPA requirements of 40-inches (1016 mm) minimum discharge above the roof when mounted on a minimum 8-inch (203 mm) high roof curb.

Grease Containers

- Drain connection shall be constructed of aluminum and allow for single-point drainage of grease, water or other residues.
- Grease trap container shall be constructed from polypropylene. The unit shall collect grease and water from the fan and extract the grease from the water for ease of grease disposal.



Easy Clean Options

- Hinge kit shall be constructed of heavy-gauge aluminum hinges and shall include hold-open mechanism.
- Non-stick wheel shall be constructed of aluminum with a non-stick coating similar to Teflon® as manufactured by DuPont™.
- Clean-Out Port shall have a hole on the outside of the windband and a grease repellent compression rubber fit, allowing access to entire wheel for cleaning.



Windband Extension

- Shall be constructed from heavy-gauge aluminum tube that raises the fan discharge height.

Belt Drive Specifications

Model USGF

Ultimate Steel Grease Fan



Spun steel exhaust fans shall be centrifugal belt-driven type. Fan wheel shall be centrifugal backward-inclined type. The wheel shall be constructed of steel and coated with a non-stick coating similar to Teflon® as manufactured by DuPont™. Wheel shall include a wheel cone carefully matched to the inlet cone for precise running tolerances. Wheels shall be statically and dynamically balanced.

The fan housing shall be constructed of 16-gauge steel with a rigid internal support structure and shall be leakproof. The fan housing shall be constructed with a one-piece windband with an integral rolled bead for added strength and shall be joined to the curb cap with a continuously welded seam.

The fan windband shall have a Clean-Out Port, a 4-inch diameter hole on the outside of the fan's windband with a grease repellent compression rubber fit, allowing access to entire wheel for cleaning.

Motors shall be heavy-duty ball bearing type, carefully matched to the fan load, and furnished at the specified voltage, phase and enclosure. Drive frame assembly shall be constructed of heavy-gauge galvanized steel. Motors and drives shall be mounted on heavy-duty true vibration isolators, out of the airstream. Fresh air for motor cooling shall be drawn into the motor compartment through a ten-square-inch tube free of discharge contaminants. Motors and drives shall be readily accessible for maintenance.

Precision ground and polished 1-inch minimum diameter fan shafts shall be mounted in cast pillow block lubricatable ball bearings. Bearings shall be selected for a minimum L_{10} life in excess of 100,000 hours (L_{50} life of 500,000 hours) at maximum cataloged operating speed. Dual drives shall be sized for a minimum of 150% of driven horsepower. Pulleys shall be of the cast type, keyed and securely attached to the wheel and motor shafts.

Motor pulleys shall be adjustable for final system balancing. All fans shall have a dual belt and pulley system. A NEMA-3R disconnect switch shall be factory-installed and wired from the fan motor to a junction box installed outside the motor compartment.

All fans shall bear the AMCA Sound and Air Performance seal.

Each fan shall bear a permanently affixed manufacturer's engraved metal nameplate containing the model number and individual serial number for future identification.

Fans shall be Listed by Underwriters Laboratory for UL/cUL 762 Listed for all electrical components and grease removal.

Hinged base shall be constructed of heavy-gauge hinges and shall include hold-open cables for field installation.

Grease trap container shall be constructed from polypropylene. The unit shall collect grease and water from the fan and extract the grease from the water for ease of grease disposal.

Fans shall be model USGF as manufactured in the USA by Greenheck Fan Corporation headquartered in Schofield, Wisconsin.

Direct Drive Specifications

Model CW



Spun aluminum exhaust fans shall be upblast centrifugal direct drive type. The fan wheel shall be centrifugal backward-inclined, constructed of aluminum and shall include a wheel cone carefully matched to the inlet cone for precise running tolerances. Wheels shall be statically and dynamically balanced. The fan housing shall be constructed of heavy-gauge aluminum with a rigid internal support structure.

Motors shall be mounted out of the airstream on vibration isolators. Fresh air for motor cooling shall be drawn into the motor compartment through a ten-square-inch tube, free of discharge contaminants. Motors and drives shall be readily accessible for maintenance.

A disconnect switch shall be factory-installed and wired from the fan motor to a junction box within the motor compartment. A conduit chase shall be provided through the curb cap to the motor compartment for ease of electrical wiring.

All fans shall bear the AMCA Sound and Air Performance seal.

Each fan shall bear a permanently affixed manufacturer's engraved metal nameplate containing the model number and individual serial number for future identification.

A leakproof fan housing shall be constructed with a one-piece windband with an integral rolled bead for added strength. Fan shall be provided with a mounting plate, which is to be attached and sealed to the wall prior to locating the entire unit.

Fans shall be model CW or CW-HP as manufactured in the USA by Greenheck Fan Corporation headquartered in Schofield, Wisconsin.

Options and Accessories For Direct Drives

UL/cUL Listed

- Fans shall be Listed by Underwriters Laboratory for UL/cUL 705 for all electrical components.
- Fans shall be Listed by Underwriters Laboratory for UL/cUL 762 for all electrical components and grease removal.

Easy Clean Options

- Non-stick wheel shall be constructed of aluminum with a non-stick coating similar to Teflon® as manufactured by DuPont™.

Belt Drive Specifications

Model CWB



Spun aluminum exhaust fans shall be centrifugal belt-driven type. The fan wheel shall be centrifugal backward-inclined, constructed of aluminum and shall include a wheel cone carefully matched to the inlet cone for precise running tolerances. Wheels shall be statically and dynamically balanced. The fan housing shall be constructed of heavy-gauge aluminum with a rigid internal support structure. The windband shall be welded to the one-piece curb cap and on all sizes with UL/cUL 762.

Motors shall be heavy-duty ball bearing type, carefully matched to the fan load and furnished at the specified voltage, phase and enclosure. Drive frame assembly shall be constructed of heavy-gauge steel. Motors and drives shall be mounted on vibration isolators, out of the airstream where no steel-to-steel contact between rotating components and the base shall occur. Fresh air for motor cooling shall be drawn into the motor compartment through a ten-square-inch tube free of discharge contaminants. Motors and drives shall be readily accessible for maintenance.

Precision ground and polished fan shafts shall be mounted in permanently sealed, lubricated pillow block ball bearings. Bearings shall be selected for a minimum L_{10} life in excess of 100,000 hours (L_{50} life of 500,000 hours) at maximum catalogued operating speed. Drives shall be sized for a minimum of 150% of driven horsepower. Pulleys shall be of the cast type, keyed and securely attached to the wheel and motor shafts.

Motor pulleys shall be adjustable for final system balancing. A disconnect switch shall be factory installed and wired from the fan motor to a junction box installed within the motor compartment. A conduit chase shall be provided through the base to the motor compartment for ease of electrical wiring.

All fans shall bear the AMCA Sound and Air Performance seal.

Each fan shall bear a permanently affixed manufacturer's engraved metal nameplate containing the model number and individual serial number for future identification.

A leakproof fan housing shall be constructed with a one-piece windband with an integral rolled bead for added strength. Fan shall be provided with a mounting plate, which is attached and sealed to the wall prior to locating the entire unit.

Fans shall be model CWB or CWB-HP as manufactured in the USA by Greenheck Fan Corporation headquartered in Schofield, Wisconsin.

Options and Accessories For Belt Drives

UL/cUL Listed

- Fans shall be Listed by Underwriters Laboratory for UL/cUL 705 for all electrical components.
- Fans shall be Listed by Underwriters Laboratory for UL/cUL 762 for all electrical components and grease removal.

Easy Clean Options

- Non-stick wheel shall be constructed of aluminum with a non-stick coating similar to Teflon® as manufactured by DuPont™.

Smoke Control

Fan wheel shall be centrifugal backward-inclined, constructed of steel and shall include a wheel cone carefully matched to the inlet cone for precise running tolerances.

- Dual drives shall be sized for a minimum of 150% of driven horsepower.
- A NEMA-3R disconnect switch shall be factory-installed and wired from the fan motor to a junction box installed outside the motor compartment.
- Fans shall be Listed by Underwriters Laboratory for UL/cUL 705 for electrical components and UL/cUL Listed for Emergency Smoke Control Systems [500°F (260°C) for 4 hours and 1,000°F (538°C) for 15 minutes].

Fans shall be Greenheck model CUBE and USGF as specified on pages 51 and 52 with smoke control rated construction option and manufactured by Greenheck Fan Corporation in Schofield, Wisconsin, USA.

High Wind

Fans shall meet all Greenheck wind load standards and shall contain the following third-party certifications:

- Miami-Dade Certification (CUE, CUBE, CW, CWB, USGF)
- Licensed P.E. calculations shall be available for fan per ASCE 7-05 Minimum Design Loads for Buildings and Other Structures for exposure Class C, 60 foot building height, and a type II building.
- Fan shall be tested in accordance with ASTM E-330-02 Structural Performance of Exterior Windows, Doors, Skylights and Curtain Walls by Uniform Static Air Pressure Difference and Florida Building Code Test Protocol TAS-201, 202 and 203 at the ASCE 7-05 calculated design pressure.
- Licensed P.E. calculations for attachment of fan to curb shall be available for ASCE 7-05 determined design pressure.
- All calculations and testing shall be done by a state licensed P.E. and a certified test lab.

Fans shall be Greenheck model CUE, CUBE, USGF, CW and CWB as specified on pages 50 through 54 with high wind-resistant construction option and manufactured by Greenheck Fan Corporation in Schofield, Wisconsin, USA.

Seismic

Fans shall meet International Building Code (IBC) and the California Office of Statewide Health Planning and Development (OSHPD) requirements for seismic certifications as listed.

- All Greenheck seismically certified models shall be tested to the most severe seismic event on the Spectral Response Map per IBC Figures 1613.5 (1-2). Testing shall be performed under the worst case scenario, using the highest mapped seismic load, highest level occupancy category, worst case site class, and highest code mandated importance factor.
- Fans shall be shake table tested in accordance with ICC ES AC-156, in which the fans are physically subjected to the same or greater forces as experienced during a seismic event.

Fans shall be Greenheck model CUE and CUBE specified on pages 50 and 51 and model CW and CWB specified on pages 53 and 54 with seismic rated construction option and manufactured in the USA by Greenheck Fan Corporation headquartered in Schofield, Wisconsin.

Quick Delivery and Quick Build Programs



Greenheck Fan Corporation offers an extensive selection of Quick Delivery (QD) and Quick Build (QB) offerings. The QD program is Greenheck's stock program and the QB program offers configurable fans in 1, 3, 5, 10, 15 or 25 days.

Hundreds of in stock ventilation products and accessories are available for shipment to your jobsite in less than 24 hours from our strategically located warehouses throughout the world.

The Greenheck Stock and Quick Build catalog is a great resource for specific options and accessories available with QD and QB fans.



Model	Size	Best Available Program
CUE	080 through 121, 141	In Stock
CW	070 through 095, 101, 121 and 141	
CUBE	099 through 121, 141 through 200, 240 & 300	
High Pressure CUBE	141HP and 180HP	1 Day
all CUE, CW	060 through 200	
CUBE	099, 131, 220, 360 through 480	
CWB	099 through 131, 161, 200 through 300	
High Pressure CUE, CW	141HP through 180HP	
High Pressure CUBE	101HP, 161HP, 200HP, 220HP, 300HP & 360HP	
High Pressure CWB	101HP through 300HP	
Extended Pressure CUBE	161XP through 360XP	

Building Value in Air

Greenheck delivers value to mechanical engineers by helping them solve virtually any air quality challenges their clients face with a comprehensive selection of

top quality, innovative air-related equipment. We offer extra value to contractors by providing easy-to-install, competitively priced, reliable products that arrive on time.

And building owners and occupants value the energy efficiency, low maintenance and quiet dependable operation they experience long after the construction project ends.

Our Commitment

As a result of our commitment to continuous improvement, Greenheck reserves the right to change specifications without notice.

Product warranties can be found online at Greenheck.com, either on the specific product page or in the literature section of the website at Greenheck.com/Resources/Library/Literature.



Prepared to Support Green Building Efforts

