

## S.EV series solenoid valves

6281 EV, 6213 EV, 290 EV

Bürkert Fluid Control Systems  
Christian-Bürkert-Straße 13-17  
74653 Ingelfingen  
Germany

Tel.: +49 7940 100  
Fax: +49 7940 1091204

[info@burkert.com](mailto:info@burkert.com)  
[www.burkert.com](http://www.burkert.com)



**burkert**  
FLUID CONTROL SYSTEMS

# S.EV series

## Universal valves

The S.EV valve series is the basis for Bürkert servo-assisted diaphragm valves.

It combines three different switching technologies and features time-tested expertise and high quality.

This series is ideal for use in water, compressed air or vacuum systems. The technical design and diversity of materials make it a universal solution for your requirements.



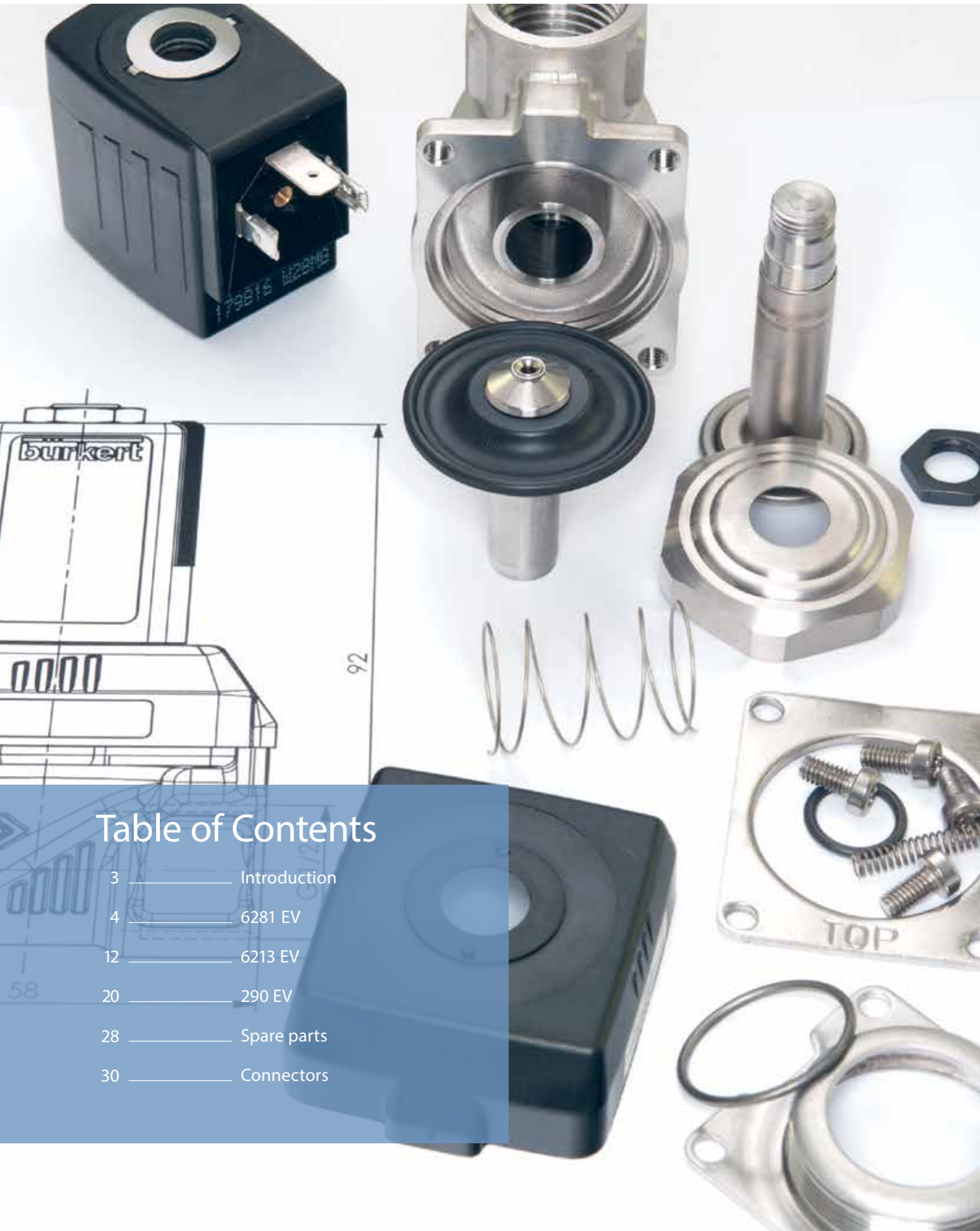

The transparent and well-structured product spectrum helps customers to choose the right valve quickly.



### Table of Contents

- 3 Introduction
- 4 6281 EV
- 12 6213 EV
- 20 290 EV
- 28 Spare parts
- 30 Connectors

### The S.EV series

	Type 6281 EV	 Differential pressure bar	0.5	Standard
	Type 6213 EV		0.0	Spring coupled
	Type 290 EV			Fixed coupled

# Overview of versions and properties

The servo-assisted 6281 EV diaphragm valve is used for controlling liquids and gases.

The following versions are available:

- Normally closed (NC) and normally open (NO)
- Pressure range: 0.2 ... 16 bar
- Media temperatures: -30 ... +120 °C
- Sealing materials: NBR, FKM, EPDM
- Diameters: DN 13 ... 50 mm
- Body materials: Brass, stainless steel 1.4401
- Process connections: 3/8 ... 2 in G, NPT, Rc
- Max. Kv value: 30 m<sup>3</sup>/h



Stainless steel

Brass

Servo-assisted diaphragm valve: Pilot control by plunger valve

The 6281 EV uses a direct-acting plunger valve as the pilot valve. The main seat is sealed by an elastomer diaphragm. A minimum pressure between the valve inlet and outlet is necessary for opening and closing.

Different certifications are available depending on the application and the regional utilisation of the valve. Additional technical versions offer customised solutions.

The following table gives an overview of the available options, certifications and certificates.

Certifications:	Certificates:	Options:
ATEX	Drinking water KTW + W270	Normally open (NO)
IEC EX	Watermark	Power reduction with Type 2511
KOSHA	BAM-tested	Block assembly
NEPSI		Manual actuation
UL/UR		Free of oil, grease and silicon
CSA (in preparation)		Stainless steel body
		Dezincification-resistant brass
		Nickel-plated brass, 5 µm

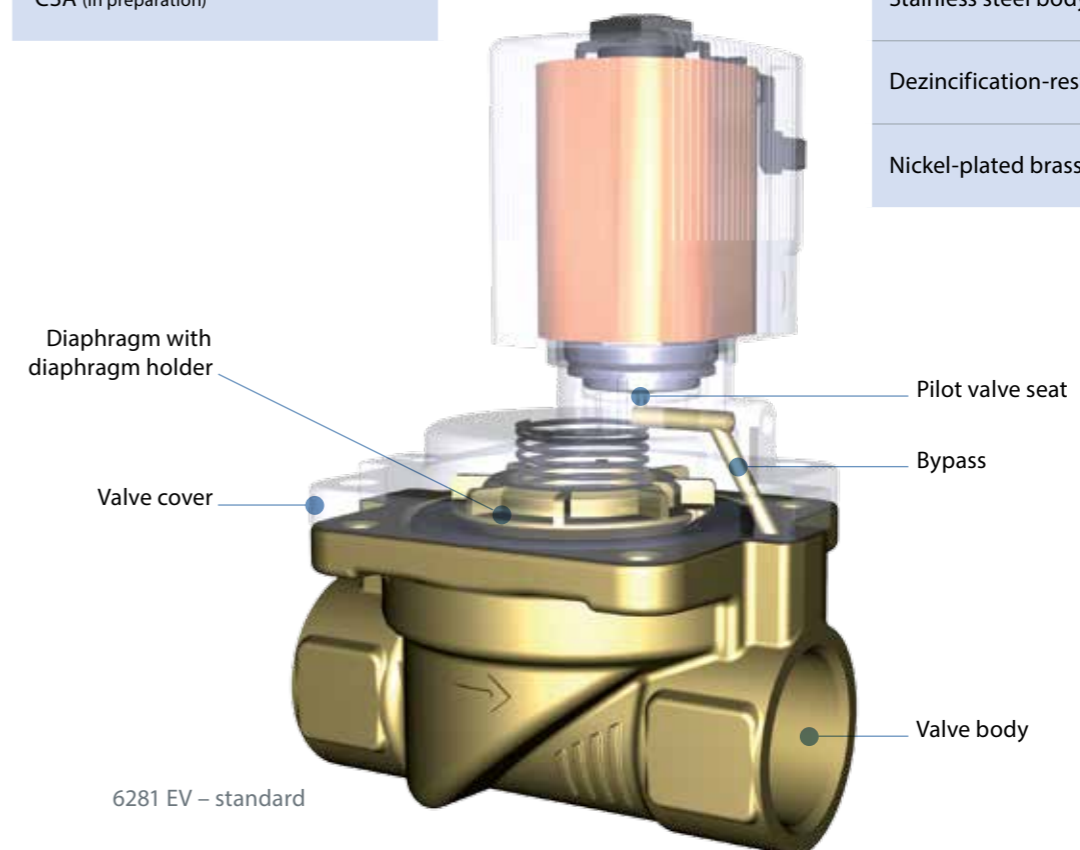

6281 EV – standard

## Versions and benefits

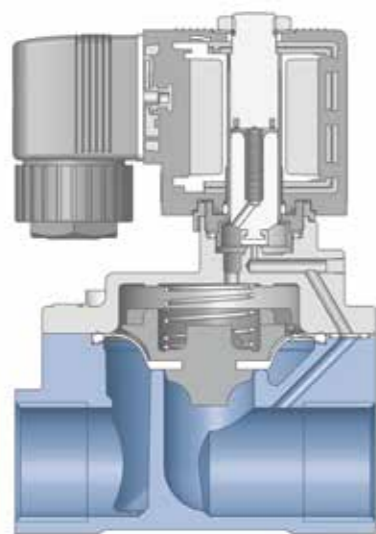

### Standard

The brass version of the valve is suitable for controlling neutral liquids and gases in pressure and vacuum applications. Available connections include G and NPT as well as DIN flanges.

#### Special features:

Dezincification-resistant versions are available for Australian Watermark certification.

The stainless steel and nickel-plated brass versions enable use in mildly acidic and alkaline solutions and with ultra pure water and drinking water. These versions are also free of non-ferrous metals.

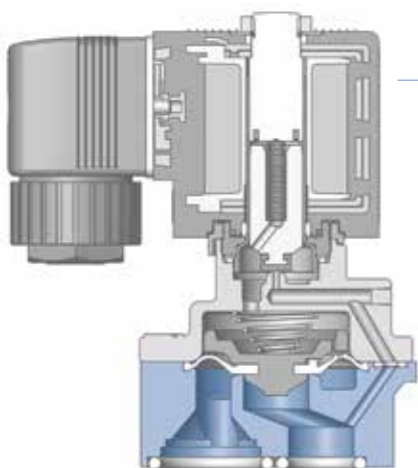

### Block flange

The compact design of the overall system is often important for installation of the valves in customised applications. To save space it helps to use a block flange, which can be mounted directly on the customer-specific fluidic components.

The block flange of the 6281 EV, manufactured from durable PPS, minimises the installation space in the system and is resistant to mildly acidic and alkaline solutions.

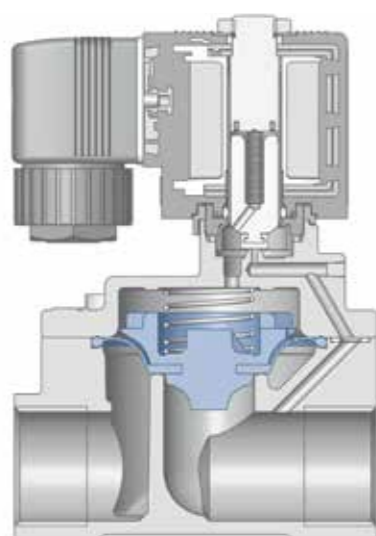

### Damped design for quiet closing

The core of a servo-assisted diaphragm valve is the diaphragm /diaphragm holder that closes the main valve seat. While the rigid diaphragm holder is made of high-quality PPS, there is a choice of FKM, EPDM and NBR for the diaphragm. The design of the inner valve contours and especially of the diaphragm holder and diaphragm are decisive for the noise level during closing of the valve. For this reason, the 6281 EV features a damped design to reduce noise during closing.

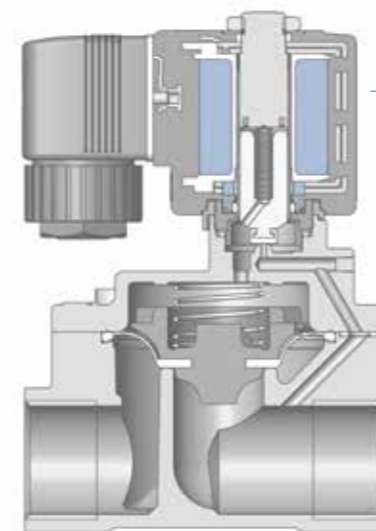

### Pulse coils

Pulse coil versions are the ideal solution for applications with low frequency switching. The switching process is achieved by a short electrical pulse. A permanent magnet ensures that the valve opens. The benefit is the low power consumption and the low heat development in the valve. This prevents the formation of scales in the valve, which means increased switching reliability. The design of the valve uses 2-wire technology.

#### Special feature:

Standard connector (DIN EN 175301-803 Form A) with electronic adaptation for 3-wire technology.

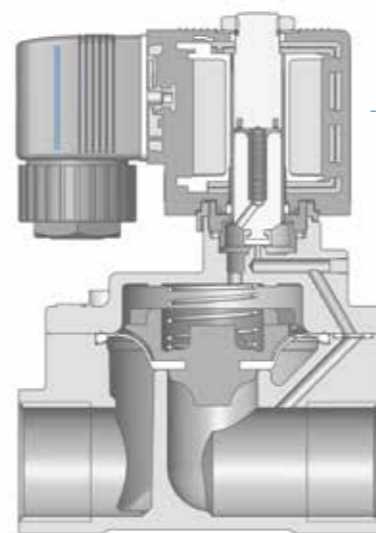

### Electronic power reduction

In addition to a power-reduced coil, electronic power reduction is also possible. In this version a small electronic component in the standard connector ensures that the pilot valve switches from inrush to holding power after about 350 ms. The benefit is the same as with the pulse coil.

#### Special feature:

Standard connector LR (DIN EN 175301-803 Form A) with power reduction also available as accessory.

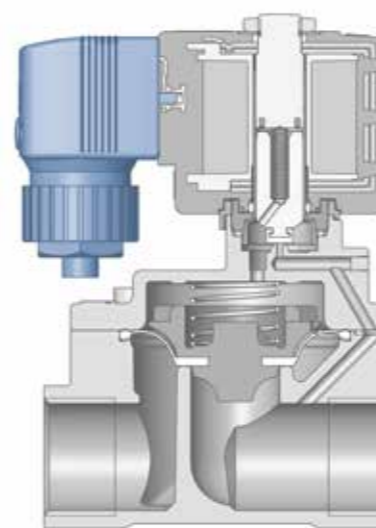

### Explosion protection

The explosion protected version of the 6281 EV can be used in Zone 1. For this purpose the encapsulated coil is provided with a moulded cable and an integrated suppressor circuit.

#### Special features:

For use in Zone 2, a tested, detachable plug-type connector that complies with Cat. 3GD is also available.

# The product spectrum at a glance

On these two pages you will learn more about the technical details and options of the 6281 EV, to help you choose the right product for your requirements.

Brass (0.2 ... 16 bar)															
Functioning principle	G, NPT	Diameter [mm]	Kv value water [m³/h]	Voltage/frequency [V/Hz]			Polyamide coil			Epoxy coil			Ex version*		
				24/DC	24/50-60	230/50-60	NBR -10 ... +80 °C	FKM 0 ... +90 °C	EPDM -30 ... +90 °C	NBR -10 ... +80 °C	FKM 0 ... +120 °C	EPDM -30 ... +100 °C	NBR -10 ... +80 °C	FKM 0 ... +90 °C	EPDM -30 ... +90 °C
NC	3/8	13	3.8	x	x	x	x	A	x	A	x	A	A	A	A
	1/2	13	3.8	x	x	x	x	A	x	A	x	A	x	A	A
	3/4	13	3.8	x	x	x	x	A	x	A	x	A	A	A	A
	3/4	20	8.5	x	x	x	x	A	x	A	x	A	x	A	A
	1	20	8.5	x	x	x	x	A	x	A	x	A	A	A	A
	1	25	12	x	x	x	x	A	x	A	x	A	x	A	A
	1 ¼	25	12	x	x	x	x	A	x	A	x	A	x	A	A
	1 ¼	40	23	x	x	x	x	A	x	A	x	A	x	A	A
	1 ½	40	30	x	x	x	x	A	x	A	x	A	x	A	A
	2	40	30	x	x	x	x	A	x	A	x	A	x	A	A
	2	50	40	x	x	x	x	A	x	A	x	A	x	A	A
	2 ½	50	40	x	x	x	x	A	x	A	x	A	x	A	A
NO	3/8	13	3.8	x	x	x	-	-	-	x	A	A	A	A	A
	1/2	13	3.8	x	x	x	-	-	-	x	A	A	A	A	A
	3/4	13	3.8	x	x	x	-	-	-	x	A	A	A	A	A
	3/4	20	8.5	x	x	x	-	-	-	x	A	A	A	A	A
	1	20	8.5	x	x	x	-	-	-	x	A	A	A	A	A
	1	25	12	x	x	x	-	-	-	x	A	A	A	A	A
	1 ½	25	12	x	x	x	-	-	-	x	A	A	A	A	A
	1 ¼	40	23	x	x	x	-	-	-	x	A	A	A	A	A
	1 ½	40	30	x	x	x	-	-	-	x	A	A	A	A	A
	2	40	30	x	x	x	-	-	-	x	A	A	A	A	A
	2	50	40	x	x	x	-	-	-	x	A	A	A	A	A
	2 ½	50	40	x	x	x	-	-	-	x	A	A	A	A	A

x = available

A = on request

- = not available

\*= available in 24/UC and 230/UC

Stainless steel (0.2 ... 16 bar)															
Functioning principle	G, NPT	Diameter [mm]	Kv value water [m³/h]	Voltage/frequency [V/Hz]			Polyamide coil			Epoxy coil			Ex version*		
				24/DC	24/50-60	230/50-60	NBR -10 ... +80 °C	FKM 0 ... +90 °C	EPDM -30 ... +90 °C	NBR -10 ... +80 °C	FKM 0 ... +120 °C	EPDM -30 ... +100 °C	NBR -10 ... +80 °C	FKM 0 ... +90 °C	EPDM -30 ... +90 °C
NC	1/2	13	3.8	x	x	x	x	A	x	A	x	A	A	x	A
	3/4	20	8.5	x	x	x	x	A	x	A	x	A	A	x	A
	1	20	8.5	x	x	x	x	A	x	A	x	A	A	x	A
	1	25	12	x	x	x	x	A	x	A	x	A	A	x	A
	1 1/4	25	12	x	x	x	x	A	x	A	x	A	A	x	A
	1 1/2	40	30	x	x	x	x	A	x	A	x	A	A	x	A
	2	40	30	x	x	x	x	A	x	A	x	A	A	x	A
NO	1/2	13	3.8	x	x	x	-	-	-	A	x	A	A	A	A
	3/4	20	8.5	x	x	x	-	-	-	A	x	A	A	A	A
	1	25	12	x	x	x	-	-	-	A	x	A	A	A	A
	1 1/4	25	12	x	x	x	-	-	-	A	x	A	A	A	A
	1 1/2	40	30	x	x	x	-	-	-	A	x	A	A	A	A
	2	40	30	x	x	x	-	-	-	A	x	A	A	A	A
	2	50	40	x	x	x	-	-	-	A	x	A	A	A	A

If you do not find a version that suits your purposes, our sales team will be glad to offer you individual assistance. Of course, we also offer solutions that can be customised for your individual requirements.

## Examples of applications

### Irrigation / sprinkler systems

In greenhouses or open fields, pipes with process connections from ½" to 2" are used for irrigation and sprinkling. The water pressure is between 2 and 6 bar and the free outlet of the pipe achieves a constant sufficient differential pressure between the valve inlet and outlet. The servo-controlled 6281 EV valve is a reliable and cost-effective solution for this application.

### Drinking water and foods

Drinking water and food applications place special requirements on the media-contacting materials of the valves. Body materials, and the plastics and elastomers used have to comply with stringent national and international standards. The type 6281 EV fulfils these requirements with extensive certifications.

### Milking parlour

Milking parlour technology normally uses a standard household water pressure of 2 to 10 bar maximum. The use of disinfecting and cleaning agents, as well as the manure from the cows contribute to an aggressive atmosphere. The control systems and valves are therefore manufactured from plastic or stainless steel.

The 6281 EV valve fulfils these requirements with its stainless steel body and epoxy encapsulated coil featuring IP 65 protection.



Filling system for drinking water

# Overview of versions and properties

The spring coupled 6213 EV servo-assisted diaphragm valve was developed for controlling liquids and gases. The spring coupling causes partial opening of the main valve at a differential pressure of nearly zero bar. The special HP00 version is available for safety-related requirements or special requirements for opening and closing.

The following versions are available:

- Normally closed (NC)
- Pressure range: 0\* ... 10 bar
- Media temperatures: -30 ... +120 °C
- Sealing materials: NBR, FKM, EPDM
- Diameters: DN 10 ... 40 mm
- Body materials: Brass, stainless steel 1.4408 (316), red brass
- Process connections: 1/4 ... 2 in G, NPT, Rc, block assembly
- Kv value up to max. 30 m<sup>3</sup>/h

(\* HP00 version)



Regional and industry-specific certifications and options are also available, which makes it easier to choose the right valve. The following table gives an overview of the available versions.

Certifications:	Certificates:	Options:
VDE	Drinking water KTW + W270	Block assembly
ATEX	NSF 61 (brass)	Gas and vacuum version
IEC EX	Watermark	Free of oil, grease and silicon
KOSHA	BAM-tested	Dezincification-resistant brass body
NEPSI		Nickel-plated brass body
UL		Stainless steel body
CSA (in preparation)		
Safety shut-off valve in accordance with DIN EN ISO 23553-1		

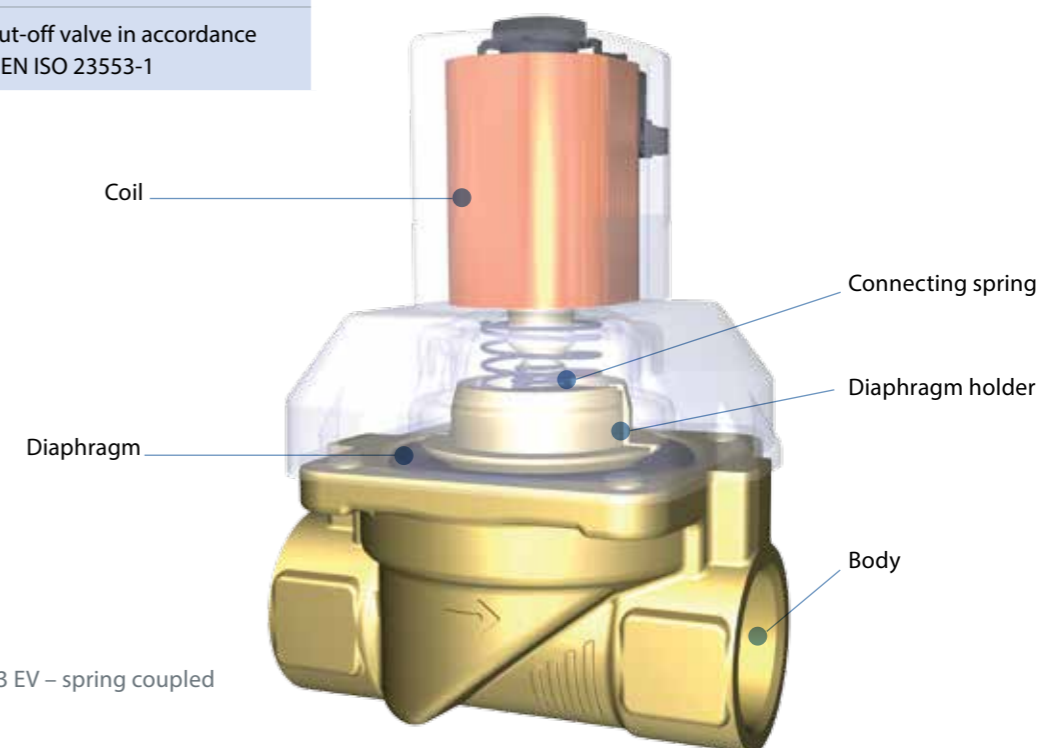

6213 EV – spring coupled

## Diaphragm valve – spring coupled

Like other pilot-controlled valves, the spring coupled valve likewise uses the media pressure for its functionality. The addition of a direct, but "soft" mechanical connection between the main diaphragm / main piston and the core of the pilot valve provides mechanical support of the opening process.

## Versions and benefits

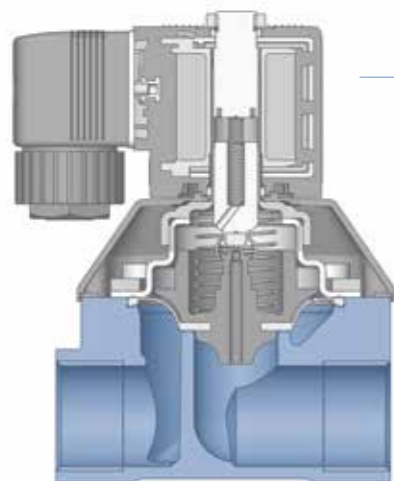

### Standard

The brass version of the valve is suitable for controlling neutral liquids and gases. Dezincification-resistant brass, nickel-plated brass and stainless steel are available as additional body materials. The last two are free of non-ferrous metal, which makes them ideal for applications with mildly acidic and alkaline solutions. The available standard process connections are G and NPT threaded.

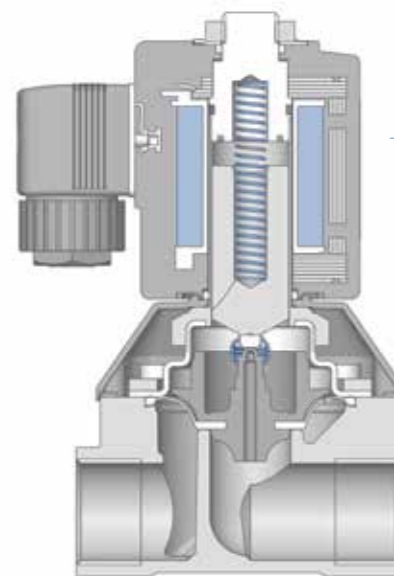

### HP00 version

The HP00 version is available in diameters 13 and 20 and it features a stronger closing spring than the standard version, as well as a more powerful coil system. This achieves high sealing power for gaseous media.

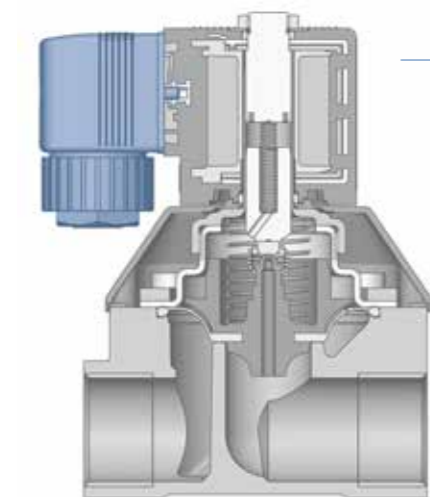

### Explosion protection

The Ex version is an encapsulated coil system. The suppressor circuit is integrated in the moulded cable end. The electrical connection is established by means of the fixed cable. The valves can be used in Category 2, Zone 1 for gases and liquids. For use in Category 3, a suitable connector socket (Type 2513) is available.

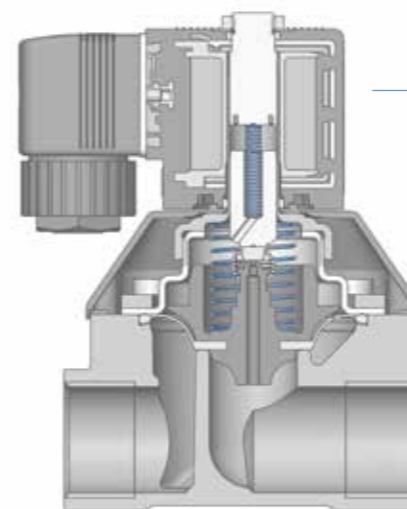

### Safety shut-off valve in accordance with DIN CERTO

This version is tested and approved in accordance with DIN EN ISO 23553-1 as a safety shut-off valve for oil burners in accordance with DINCERTO up to 10 bar. A TÜV-tested magnetic core and spring assembly ensures that the valve functions in accordance with standards and fulfils the high requirements for reliability and service life.

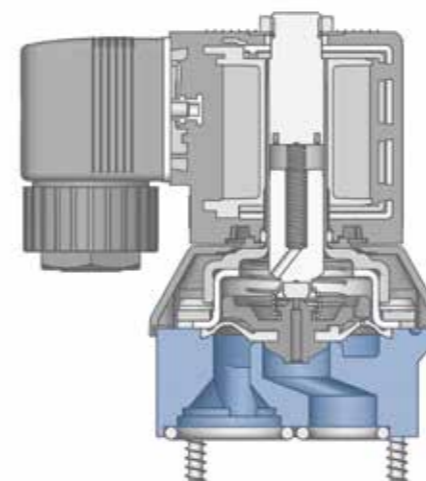

### Block flange

The compact design of the overall system is often important for installation of the valves in customised applications. To save space it helps to use a block flange, which can be mounted directly on the customer-specific fluidic components. The block flange of the 6213 EV, manufactured from durable PPS, minimises the installation space in the system and is resistant to mildly acidic and alkaline solutions. It is available in diameters 13 to 20.



# The product spectrum at a glance

On these two pages you will learn more about the technical details and options of the 6213 EV, to help you choose the right product for your requirements.

Brass (0.2 ... 10 bar)													
Functioning principle	G, NPT	Diameter [mm]	Kv value water [m³/h]	Voltage / frequency [V/Hz]			Polyamide coil			Epoxy coil			
				24/DC	24/50-60	230/50-60	NBR -10 ... +80 °C	FKM 0 ... +90 °C	EPDM -30 ... +90 °C	NBR -10 ... +80 °C	FKM 0 ... +120 °C	EPDM -30 ... +100 °C	Ex version*
NC	1/4	10	1.3	x	x	x	x	A	x	A	x	A	A
	3/8	10	1.9	x	x	x	x	A	x	A	x	A	A
	1/2	10	1.9	x	x	x	x	A	x	A	x	A	A
	1/2	13	3.6	x	x	x	x	A	x	A	x	A	A
	3/4	13	3.6	x	x	x	x	A	x	A	x	A	A
	3/4	20	8.3	x	x	x	x	A	x	A	x	A	A
	1	20	8.3	x	x	x	x	A	x	A	x	A	A
	1	25	11	x	x	x	A	A	A	x	x	x	A
	1 ¼	25	11	x	x	x	A	A	A	x	x	x	A
	1 ½	40	30	x	x	x	A	A	A	x	x	x	A
2	40	30	x	x	x	A	A	A	x	x	x	A	
Stainless steel (0.2 ... 10 bar)													
NC	3/8	10	1.9	x	x	x	x	A	x	A	x	A	A
	1/2	13	3.6	x	x	x	x	A	x	A	x	A	A
	3/4	20	8.3	x	x	x	x	A	x	A	x	A	A
	1	20	8.3	x	x	x	x	A	x	A	x	A	A
	1	25	11	x	x	x	A	A	A	x	x	x	A
	1 ¼	25	11	x	x	x	A	A	A	x	x	x	A
	1 ½	40	30	x	x	x	A	A	A	x	x	x	A
2	40	30	x	x	x	A	A	A	x	x	x	A	

\* Pressure range deviates from standard

x = available  
A = on request

HP00 brass (0 ... 10 bar)													
Functioning principle	G, NPT	Diameter [mm]	Kv value water [m³/h]	Voltage / frequency [V/Hz]			Polyamide coil			Epoxy coil			
				24/DC	24/50-60	230/50-60	NBR -10 ... +80 °C	FKM 0 ... +90 °C	EPDM -30 ... +90 °C	NBR -10 ... +80 °C	FKM 0 ... +120 °C	EPDM -30 ... +100 °C	Ex version*
NC	1/2	13	3.6	x	x	x	A	A	A	x	x	x	A
	3/4	13	3.6	x	x	x	A	A	A	x	x	x	A
	3/4	20	8.3	x	x	x	A	A	A	x	x	x	A
	1	20	8.3	x	x	x	A	A	A	x	x	x	A
HP00 stainless steel (0 ... 10 bar)													
NC	1/2	13	3.6	x	x	x	A	A	A	A	x	x	A
	3/4	20	8.3	x	x	x	A	A	A	A	x	x	A
	1	20	8.3	x	x	x	A	A	A	A	x	x	A

If you do not find a version that suits your purposes, our sales team will be glad to offer you individual assistance. Of course, we also offer solutions that can be customised for your individual requirements.

## Examples of applications

### Electrode cooling of welding robots

Welding electrodes in welding robots used in continuous operation have to be cooled to prevent the electrode from burning and to extend the service life. This is achieved by water-cooling through a secondary pipe. Water is pumped into the cooling circuit at a pressure of 4–10 bar, depending on the electrode. The valve diameter can range from 1/2" to 2", depending on the welding system.

### Shut-off valves for oil supply systems

Oil fired systems are supplied with fuel oil via corresponding supply lines. Since this is a safety-related area, the solenoid valves used as shut-off valves in the oil firing line must fulfil special requirements. These safety requirements are fulfilled by the 6213 EV solenoid valves in accordance with DIN EN ISO 23553-1, as confirmed by TÜV/DIN CERTO.

### Osmosis system

Type 6213 EV valves can be used as inlet valves for untreated water or concentrate bypass valves in reverse osmosis systems. The media temperatures in these systems range from 7 ... 25 °C, with pressures from 6 ... 15 bar. The concentrate bypass valve is used to flush or rinse the diaphragm. This valve is designed in stainless steel to ensure resistance against the aggressive concentrate. The water inlet valve can be designed in brass, due to the non-critical untreated water.

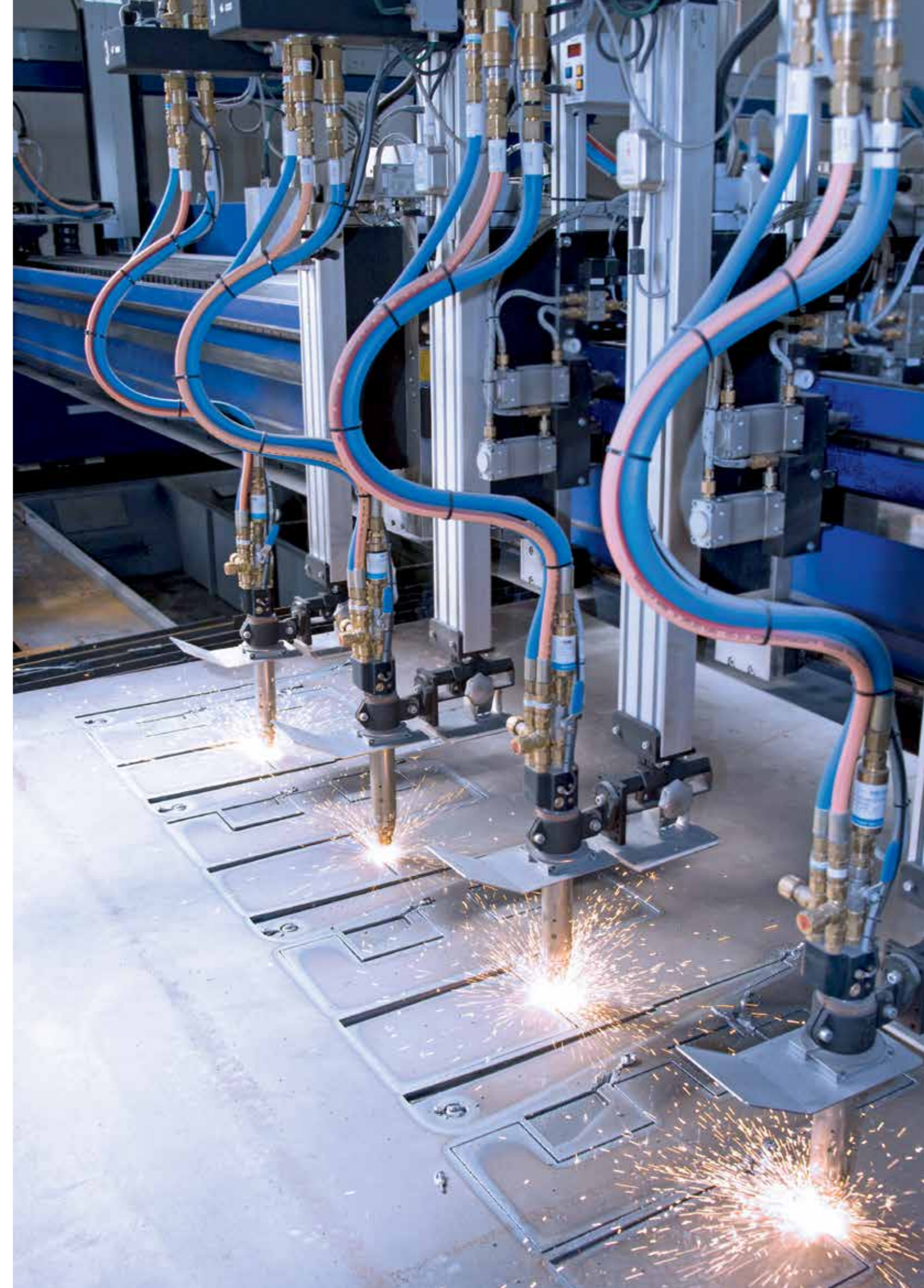

Electrode cooling  
of welding robots

## Overview of versions and properties

The fixed coupled 290 EV servo-assisted diaphragm valve was developed for reliable switching with liquids and gases starting at a differential pressure of zero bar. The core guide tube is extrusion coated and the powerful coil system features epoxy resin encapsulation.

The following versions are available:

- Switching pressure: 0 ... 16 bar
- Media temperature: - 30 ... +120 °C
- Sealing materials: NBR, FKM, EPDM
- Diameters: DN 12 ... 50 mm
- Body materials: Brass, stainless steel 1.4581
- Process connections: 1/2 ... 2 in G, NPT, flange
- Max. Kv value: 38 m<sup>3</sup>/h



Brass

Stainless steel

### Servo-assisted diaphragm valve – fixed coupled

As a servo-assisted valve the 290 EV diaphragm valve also uses the media pressure to support its functionality. However, it requires no differential pressure for reliable switching. The media pressure is necessary only for complete opening of the valve. The pilot valve needed for pilot control is fixed coupled with the main diaphragm and opens simply from the magnetic force of the main valve seat.

The main seat is sealed by an elastomer diaphragm.

No minimum pressure between the valve inlet and outlet is necessary for opening and closing.

Different certifications and certificates are available depending on the application and the regional utilisation of the valve. Additional technical versions offer customised solutions.

The following table gives an overview of the available options, certifications and certificates.

Certifications:	Certificates:	Options:
UL	BAM-tested	Flange version in grey cast iron DN 25 ... 50
UR	FDA	Flange version in VA DN 25
DVGW Gas EN 161	KTW W270	Free of oil, grease and silicon
		Mounting hole in body
		Nickel-plated brass body
		Stainless steel body
		Slide ring bearing

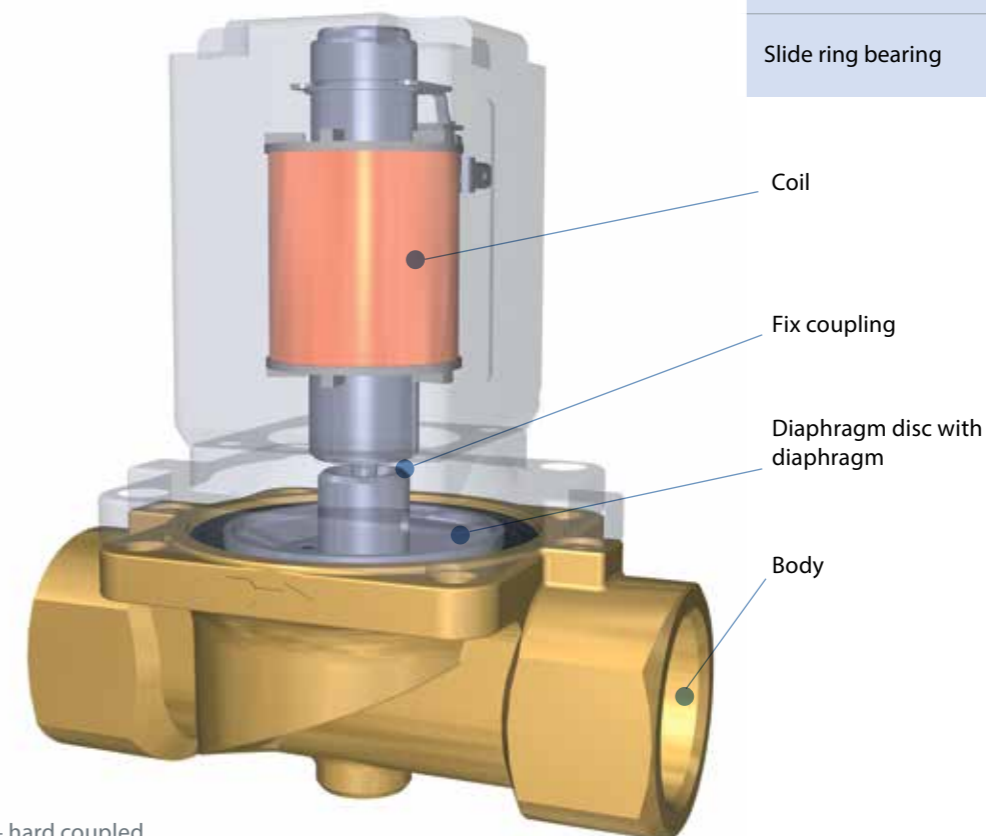

290 EV – hard coupled

## Versions and benefits

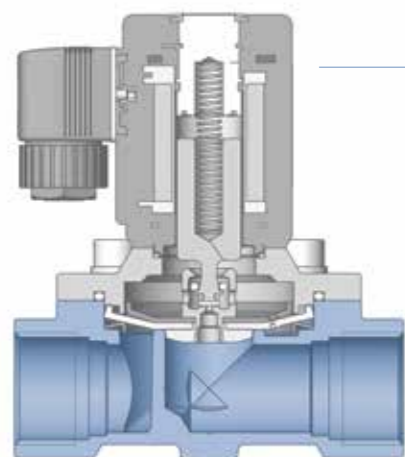

### Standard

This fixed coupled valve is suitable for controlling liquids and gases with a differential pressure starting at zero bar.

#### Special features:

The stainless steel version is also suitable for liquids that require high chemical resistance. Flange connections are available in brass, stainless steel and grey cast iron in diameters from DN 25 to DN 50.

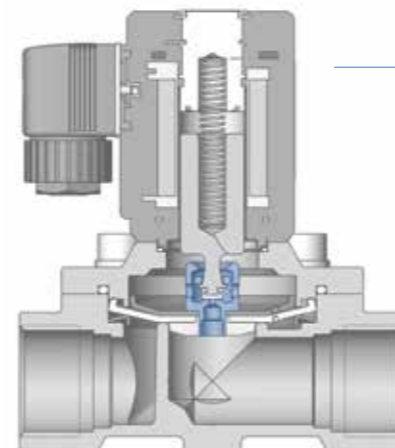

### Soft-kick function for large diameters

The valve features a soft-kick function to increase the service life. In small diameters up to DN 25 an elastomer ring serves as an additional damping element between the core and the main diaphragm. In larger diameters, this function is performed by an additional spring. Both ensure soft coupling of the main diaphragm during the opening process. The diaphragm is opened in a low-fatigue manner.

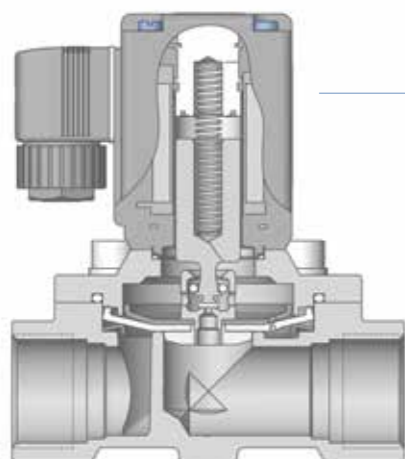

### Vibration resistance and high performance

The 290 EV valve is equipped with a block screwed and epoxy encapsulated coil. It is firmly attached to the valve body by means of four screws to ensure high stability in case of strong vibrations.

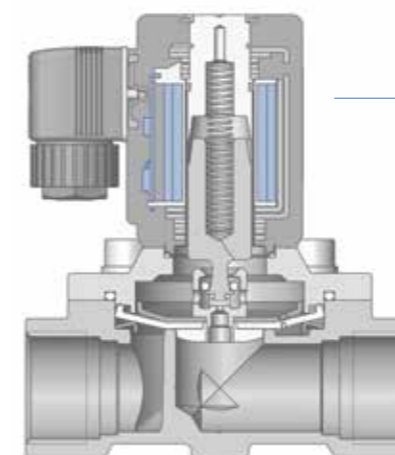
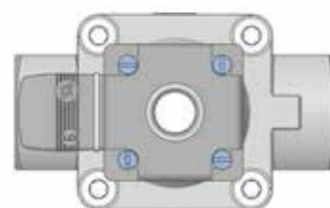

### Integrated power reduction in all DC versions

To lower the power consumption and prevent unnecessary heat, all DC versions feature integrated power reduction. After the valve opens completely the power is reduced far enough that the valve remains open.

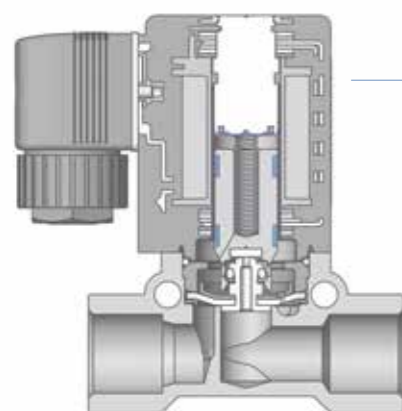

### Sliding ring bearing and damping

To reduce mechanical abrasion in use with dry gases, the 290 EV is available with sliding rings. The sliding rings serve as a guide to prevent metallic abrasion between the core and the core guide tube. An additional damping disc reduces the impact energy of the core against the stopper. Both of these measures increase the service life and stability of the valve.

# The product spectrum at a glance

On these two pages you will learn more about the technical details and options of the 290 EV, to help you choose the right product for your requirements.

Brass																					
Functioning principle	G, NPT	Diameter [mm]	Kv value water [m³/h]	Pressure [bar]	Voltage/frequency [V/Hz]									Pressure [bar]	Kv value water [m³/h]	Diameter [mm]	G, NPT	Functioning principle			
					24/DC			24/UC			230/50								110/50		
					FKM 0...+120 °C	EPDM -30...+120 °C	NBR -10...+80 °C	FKM 0...+120 °C	EPDM -30...+120 °C	NBR -10...+80 °C	FKM 0...+120 °C	EPDM -30...+120 °C	NBR -10...+80 °C						FKM 0...+120 °C	EPDM -30...+120 °C	NBR -10...+80 °C
NC	1/2	12	1.8	0...16	x	x	x	x	x	x	x	x	x	x	x	x	0...16	1.8	12	1/2	NC
	3/4	20	5.0	0...16	x	x	x	x	x	x	x	x	x	x	x	x	0...16	5.0	20	3/4	
	1	25	10.0	0...16	A	x	x	x	x	x	x	x	A	x	x	x	0...16	10.0	25	1	
	1 1/4	32	16.0	0...12	A	A	x	A	A	x	x	x	A	A	x	x	0...12	16.0	32	1 1/4	
	1 1/2	40	16.0	0...12	A	A	x	A	A	x	x	x	A	A	x	x	0...12	16.0	40	1 1/2	
	2	50	38	0...12	A	A	A	A	A	x	A	x	A	A	x	x	0...12	38	50	2	
Stainless steel																					
NC	1/2	12	1.8	0...16	x	x	x	x	x	x	x	x	x	x	x	x	0...16	1.8	12	1/2	NC
	3/4	20	5.0	0...16	x	x	A	x	x	A	x	x	x	x	A	x	0...16	5.0	20	3/4	
	1	25	10	0...16	x	A	A	x	x	A	x	x	x	A	x	x	0...16	10	25	1	

x = available  
A = on request

If you do not find a version that suits your purposes, our sales team will be glad to offer you individual assistance. Of course, we also offer solutions that can be customised for your individual requirements.

## Examples of applications

### Mains water protection in industrial applications

Mains water protection systems provide protection against unnoticed leaks in buildings and systems and are activated at night and on weekends. In case of a power outage or shut-down the valve must reliably close the supply to the system. The typical system pressure is between 3 and 10 bar, with a media temperature of ca. 10 ... 35 °C. The fixed coupled 290 EV valve performs this task reliably, since it also switches without differential pressure. It is available in the required diameters, both as a threaded and flange version. Our 6213 EV valve, which is VDE approved, is suitable for mains water protection in households.

### Motor vehicles

Applications involving equipment mounted on motor vehicles place high requirements on the vibration resistance and the protection type. These systems are frequently closed cooling or gas circuits with a low differential pressure. The type 290 EV fulfils these requirements with its vibration-proof block screwed coil and the IP 65 connector. The fixed coupled valve switches reliably at a differential pressure of zero bar.

### Oxygen application

The crude steel production process starts with insertion of a water-cooled lance into the molten metal. This lance injects pure oxygen at a pressure of ca. 10 bar into the molten mass for a period of about one hour. The oxygen oxidises the companion elements and the resulting gaseous oxides escape through the exhaust gas flue. Type 290 EV valves are used both for the water cooling and for injection of the pure oxygen. Besides the harsh, hot ambient conditions, certification of the valves for use with oxygen is central here. To prevent a reaction with the oxygen in the valve, all media-contacting, non-metal seal materials are designed to be absolutely oil- and grease-free and are BAM-tested accordingly.

Car wash systems as a typical application for solenoid valves S.EV series

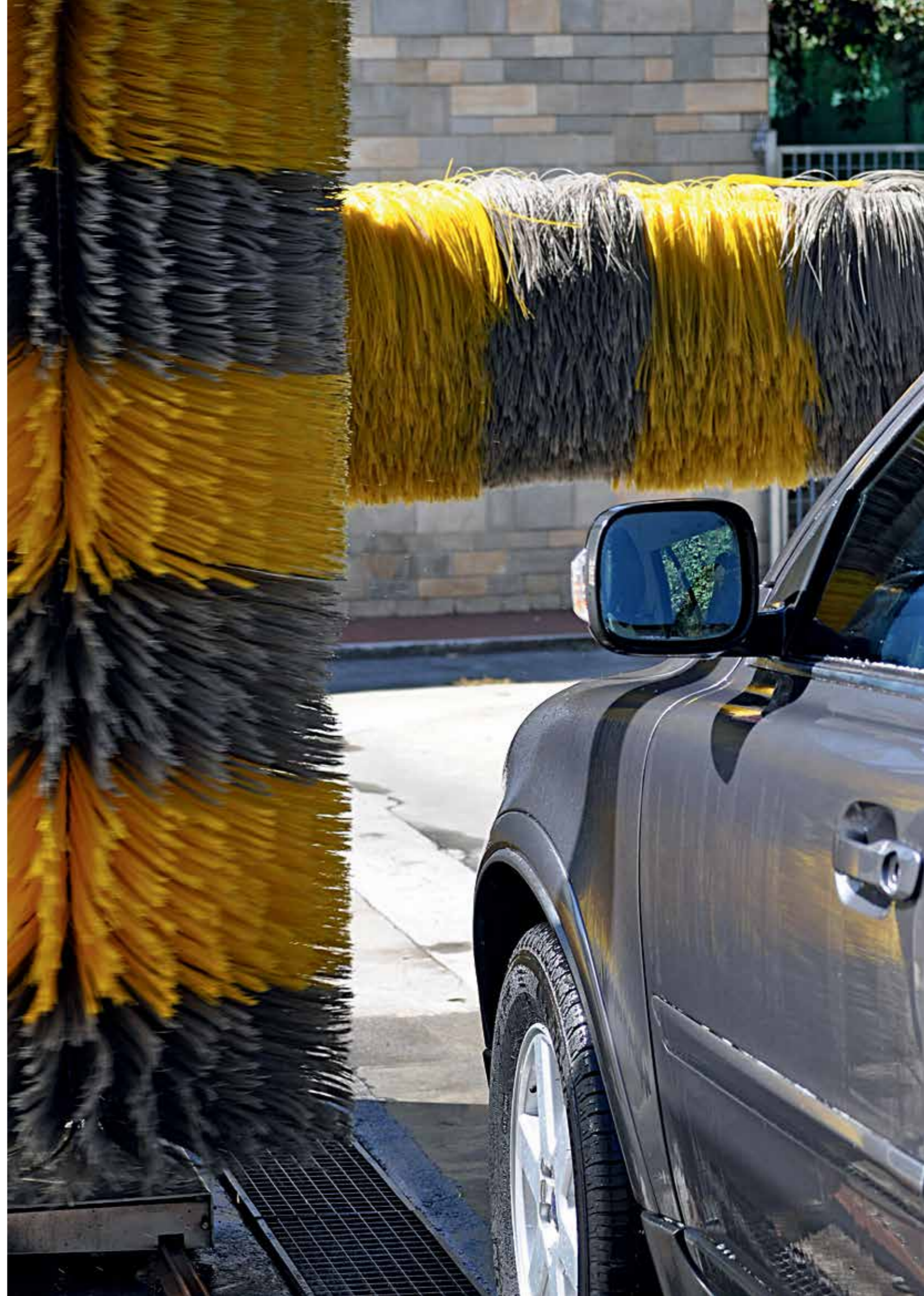

# Spare parts sets

On this page you will find the available spare parts and wear parts sets for types 6281 EV, 6213 EV and 290 EV.



Type 6281 EV

Different spare parts sets  
Based on the functioning principle

- 1: Coil set
- 2: Stopper set
- 3: Wear parts set

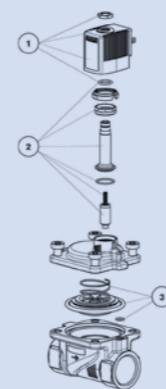

WW A – Normally closed

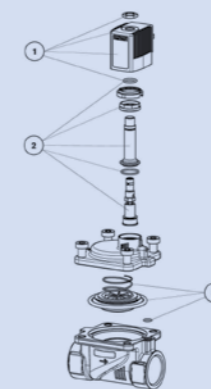

WW B – Normally open



Type 6213 EV

Different spare parts sets  
Based on diameter

- 1: Coil set
- 2: Stopper set
- 3: Wear parts set

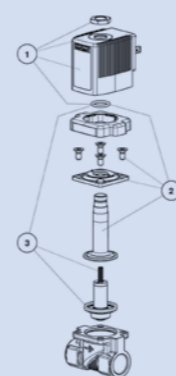

DN 10 mm

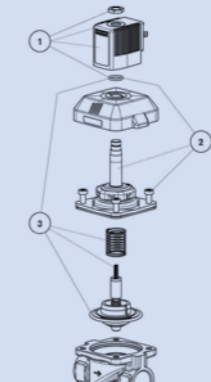

DN 13 ... 20 mm

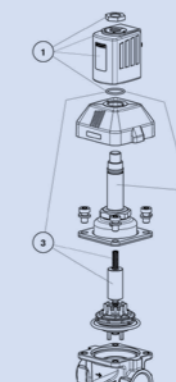

DN 25 ... 40 mm



Type 290 EV

Different spare parts sets  
Based on diameter

- 1: Coil set
- 2: Stopper set
- 3: Wear parts set

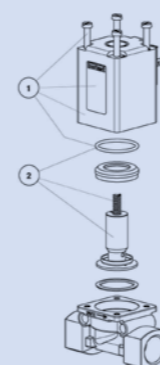

DN 12 mm

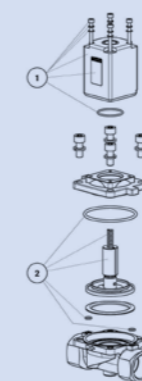

DN 20 ... 25 mm

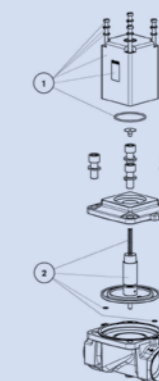

DN 32 ... 50 mm

# Accessories: Connector sockets

The connector socket 2508, available as an accessory, supplements and expands the application spectrum of the S.EV series. In addition to visualisation of the switching state, versions are available with an integrated rectifier or suppressor circuit for the electrical system.

Without circuitry, 2-pin + protective conductor

Voltage	Constant current	Order no. without cable
0 to 250 V/AC/DC	max. 6 A	008 376
Technical data		Order no.
with conduit threads		137 943



With rectifier and varistor

Voltage	Constant current	Order no. without cable
12 to 240 V/AC/DC	max. 1 A	008 374

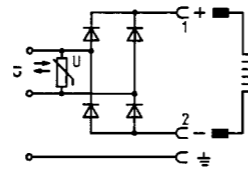

With LED

Voltage	Constant current	Order no. without cable	Order no. 3 m cable
12 to 24 V/AC/DC	max. 6 A	008 360	783 575
100 to 120 V/AC/DC	max. 6 A	008 361	-
200 to 240 V/AC/DC	max. 6 A	008 362	783 577

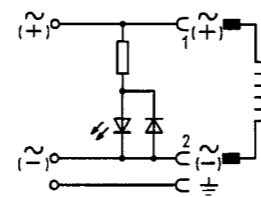

With LED and varistor

Voltage	Constant current	Order no. without cable	Order no. 3 m cable
12 to 24 V/AC/DC	max. 6 A	008 367	783 579
100 to 120 V/AC/DC	max. 6 A	008 368	783 581
200 to 240 V/AC/DC	max. 6 A	008 369	783 583
Technical data			Order no.
with conduit threads			137 944 M
with conduit threads			137 945 N
with conduit threads			137 946 P

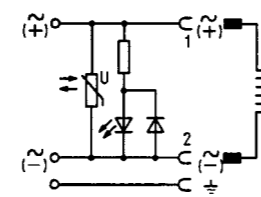

# Bürkert – Close to You

For up-to-date addresses please visit us at [www.burkert.com](http://www.burkert.com).



Publisher: © and concept: Christian Bürkert GmbH & Co. KG | Implementation: Scanner GmbH |  
Photos: Münch Lichtbilderei, Stuttgart; Studio Flamisch, Düsseldorf; iStockphoto.com; fotolia.com |  
3D drawings: 3D Sales Technologies GmbH. All persons are employees of Bürkert. Thanks to everyone for your active support!