



UL/cUL 705 Power Ventilators
E40001 - EQB



UL/cUL 705 is optional and must be specified.

Model EQB is AMCA Licensed for Sound and Air Performance

Best Available Program
10 Days

Model EQB Belt Drive

Model EQB is ideal when clean air, quiet and economical operation is required. The unique octagonal housing of formed galvanized steel panels provides for exceptional strength at significantly lower cost.

Quick Delivery / Quick Build Performance

Capacities range from 550 to 23,000 cfm and up to 3 in. wg of static pressure.

Standard Construction
Octagonal galvanized housing
Aluminum mixed flow wheel
EZ Tension System for belt adjustment
NEMA-1 disconnect switch
Options and Accessories
Motor cover
Inlet and outlet guards
Vibration isolators
Access doors
Extended wiring pigtail
Thrust restraints
UL/cUL Listed Power Ventilators

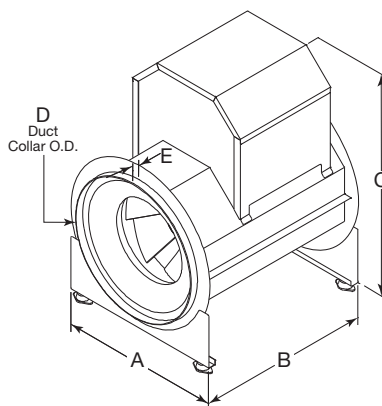

Dimensions for EQB

Model Size	A	B	C*	D	E
9	19 ³ / ₈	22	28 ³ / ₄	14 ¹ / ₄	1 ³ / ₈
12	22 ⁵ / ₈	26 ⁵ / ₈	32 ³ / ₄	17 ¹ / ₂	1 ¹ / ₂
15	26 ⁵ / ₈	29 ⁵ / ₈	38	21 ¹ / ₈	1 ¹ / ₂
16	28 ¹ / ₄	31 ¹ / ₈	32 ³ / ₄	17 ¹ / ₂	1 ¹ / ₂
18	30 ⁷ / ₈	33 ¹ / ₈	42 ⁵ / ₈	25 ⁵ / ₈	1 ¹ / ₂
20	32 ⁷ / ₈	35 ³ / ₄	47	28	1 ³ / ₈
22	36 ⁵ / ₈	39 ¹ / ₄	49 ⁵ / ₈	31 ¹ / ₄	1 ³ / ₈
24	40	42 ⁵ / ₈	53 ¹ / ₄	34 ¹ / ₄	1 ³ / ₈
27	42 ⁷ / ₈	45 ⁵ / ₈	58	37 ³ / ₄	1 ³ / ₈
30	48	52 ¹ / ₄	63 ⁵ / ₈	42	1 ⁷ / ₈

*Motor cover is optional. Size may be greater depending on motor. All dimensions are in inches.