

Laboratory Exhaust Systems

Vektor[®]-MH and Vektor[®]-MD

Mixed Flow High Plume and High Plume Dilution Blower



VEKTOR[®]



 **GREENHECK**
Building Value in Air.

June
2017

Vektor-MH High Plume and Vektor-MD High Plume Dilution Blower



Greenheck's Vektor-MH high plume and Vektor-MD high plume dilution blowers are designed to efficiently exhaust laboratory fumes and odors high above any air intakes on the same or surrounding buildings. Utilizing a patented mixed flow impeller design, the space saving configuration of the Vektor-MH and MD maximizes air movement with reduced sound and energy.

Vektor MH and MD Benefits

- Complete system with single source supplier
- Conforms to standards and codes:
 - NFPA 45 Standard on Fire Protection for Laboratories Using Chemicals
 - ASHRAE HVAC Applications Chapter 45 – Building Air Intake and Exhaust Design
 - ANSI Z9.5 – Standards for Laboratory Ventilation
 - UL 705 – Power Ventilators, Electrical
- AMCA Licensed performance
- Bifurcated housing for safe and easy maintenance
- Minimal roof deck space
- No guy wires up to 125 mph wind speed (201 km/h)



Vektor-MD Patents
Manufactured by Greenheck Fan Corp.
under the following patent numbers:
U.S. Patents:
No. 7048499, 7320636, 7682231
Mexico Patents:
No. 243465, 258949
China Patents:
No. 01813109.3, 200580006160.6,
200580006162.5
Singapore Patents:
No. 124106, 124135
Hong Kong Patent:
No. 1110926, 1114659
India Patents:
No. 253764
Other U.S. and Foreign
Patents Pending



Vektor-MH

High Plume with High Velocity Discharge Nozzle

The Vektor-MH for high plume laboratory exhaust utilizes an engineered conical discharge to maximize the effective plume height. The Vektor-MH has a single fan capacity up to 47,000 cfm and 11 in. wg (22,180 l/s and 2,740 Pa).

- The nozzle has a smooth transition from fan to discharge minimizing pressure losses
- No abrupt changes in area maximizing fan efficiency
- Multiple discharge nozzles per fan size to custom-tailor discharge velocity and plume rise
- 3,000 ft/min. (15.2 m/s) minimum discharge velocity per ANSI Z9.5
- Licensed to bear the AMCA Sound and Air Performance Seal

Vektor-MD

High Plume Dilution with High Velocity Nozzle and Entrainment Windband

The Vektor-MD for high plume dilution entrains ambient air to assist in the dilution of contaminated laboratory exhaust. The Vektor-MD has a single fan capacity up to 83,000 cfm and 11.5 in. wg (39,170 l/s and 2,860 Pa).

- Increased dilution and safety while maintaining effective plume height
- Higher nozzle velocity creates higher dilution percentage
- Windband focuses and promotes mixing of exhaust and entrained ambient air
- 3,000 ft/min. (15.2 m/s) minimum nozzle discharge velocity per ANSI Z9.5
- Licensed to bear the AMCA Air, Sound and Induced Flow Seal

Vektor-MH

High Plume

The Vektor-MH pulls hazardous exhaust air straight through the fan into an engineered and tested conical discharge. Multiple nozzles for each sized fan allow for the maximum plume height balanced with reduced energy requirements.



Vektor-MD

Dilution with Increased Safety

The Vektor-MD with high velocity nozzle accelerates exhaust air entraining additional outside air diluting any odors or contaminants in the exhaust before exiting out the top of the windband. Up to 300% dilution of lab exhaust.

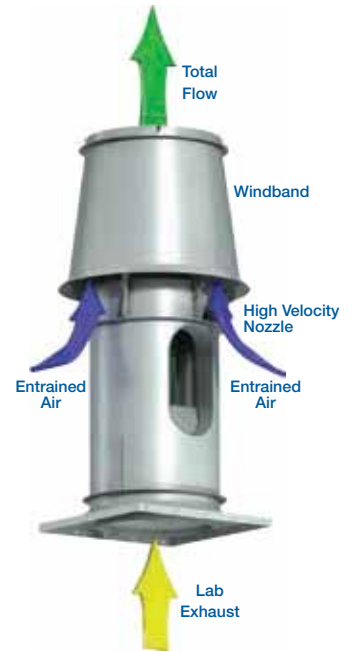

Compact Footprint



High Volume Applications



Parapet Installations

Typical Applications

- Hospital laboratories and isolation wards
- College and university laboratories
- Pharmaceutical companies
- Biotech laboratories
- Research facilities

Greenheck Vektor Value

Low maintenance option — Direct drive arrangement 4 (motor directly coupled to impeller) has once a year lubrication schedule.

Industry leading vibration testing — Vibration tested as complete assembly before shipping. Any potential issues are corrected at the factory, not at the jobsite. Testing in three planes (axial, radial and horizontal) where highest vibrations occur and components experience the vibration, the bearings or the motor. Reports are available on request.

System safety — No personnel needs to enter into the contaminated exhaust airstream. Isolation dampers are completely accessible through the outside of the plenum and drive components located in a bifurcated opening.

Life safety construction and operation —

- Systems are UL listed and AMCA licensed.
- Fan bearings are L₁₀ 200,000 hours, equivalent to 22.8 years of continuous operation at that rating.
- Belt drive configurations have a minimum of two belts with each size for entire load, giving 100% redundancy.
- Premium efficiency industrial duty motors with TEFC enclosure and inverter ready.

Vektor-MH and Vektor-MD Value Added Features

Belt or direct drive flexibility – MH and MD models are available with belt or direct drive arrangements to suit owner / operator preferences. Direct drive configurations have a high bearing life and lower maintenance. Belt drive configurations have a 2.0 drive service factor with minimum of two belts maintaining the highest level of reliability.



Belt Drive – Arrangement 9 with easy access to motor and sheaves without any contact of contaminated airstream. Includes 200,000 hour bearings and 2.0 drive service factor as standard.

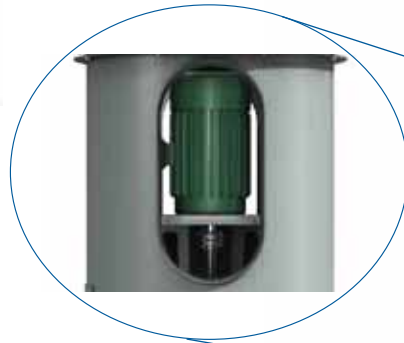

Bifurcated housing – Keeps serviceable components safe and accessible by dividing the airflow and isolating drive components completely out of the contaminated airstream.

Isolation damper – Parallel airfoil blade dampers isolate individual fans from the plenum when not in operation. Slide out design allows for service and inspection of damper and actuators without entering into the confined, contaminated plenum. The damper's low leakage design prevents back spin of the impeller. Dampers are constructed for the exhaust system's pressure and volume.

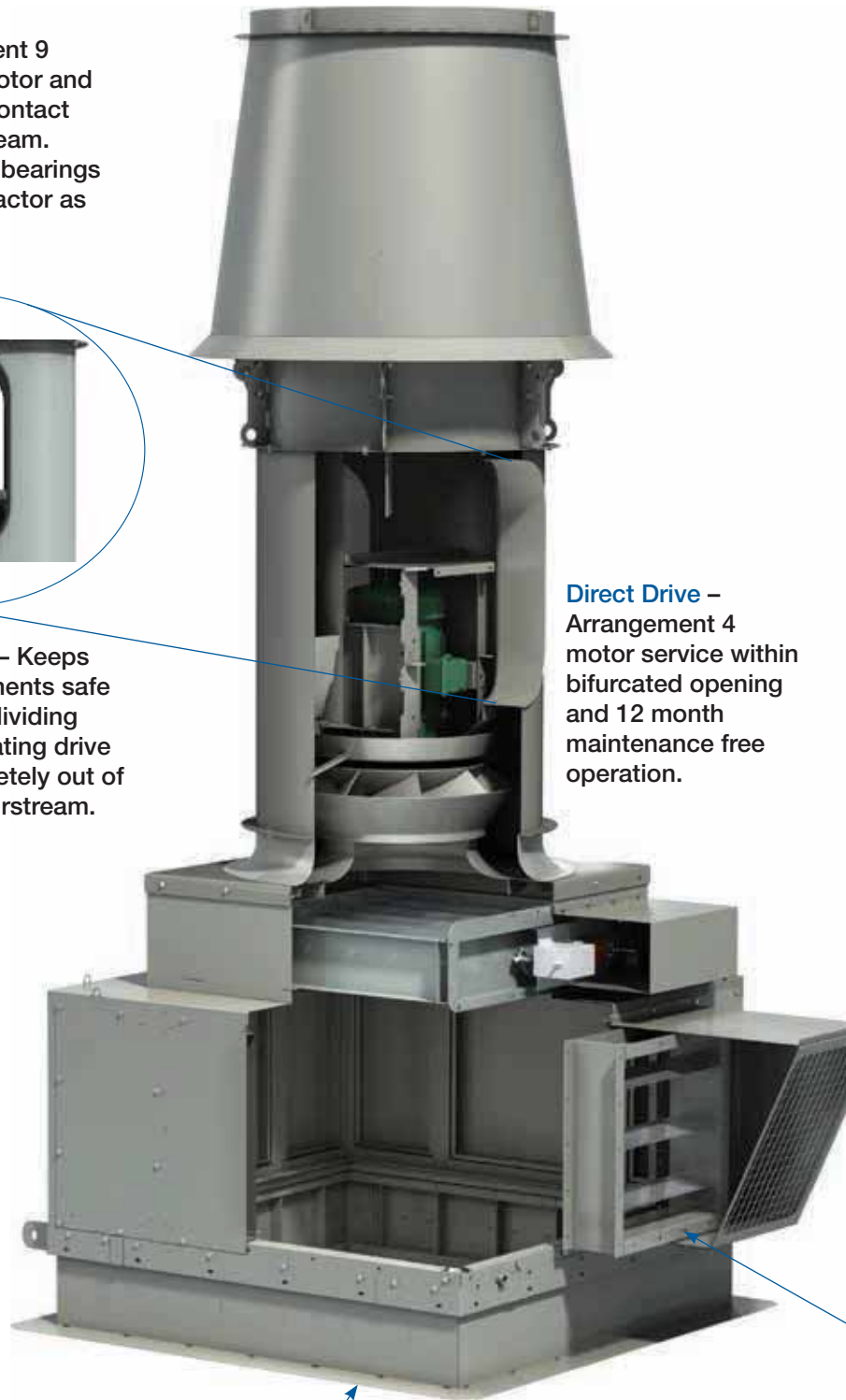

Direct Drive – Arrangement 4 motor service within bifurcated opening and 12 month maintenance free operation.

Roof curb – Reinforced heavy duty insulated roof curb provides full perimeter and cross support for multiple fan plenums up to 125 mph (201 km/h) windload without the use of guy wires.

LabCoat™ corrosion resistant coating – Electrostatically powder coated with corrosion resistant Hi-Pro™ Polyester topcoat with zinc-rich epoxy primer, protects against a wide spectrum of acids, alkalis and solvents.

LabCoat™ Cross Section

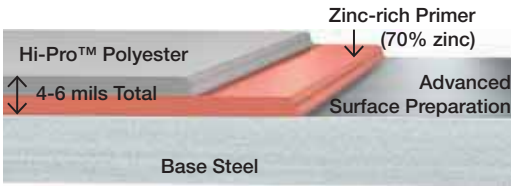

Back pressure blades – Additional blades on the back of the impeller of the arrangement 2 or 9 create a vacuum, preventing contaminated exhaust from escaping through the shaft opening into the fan housing.



Mixed flow impeller – Specially configured blades move air with lower energy consumption and reduced sound generation. Available with AMCA Spark C or B construction.



Direct Drive – Arrangement 2 with motor service and removal without any contact of contaminated airstream. Includes 200,000 hour bearings as standard.

Bypass damper – Opposed airfoil blade dampers provide for full airflow control throughout the damper's operating range. Dampers are sized specifically for volumes and pressures required on the application providing superior system control. Heavy-duty construction up to 15 in. wg (3,736 Pa). Factory provided and mounting available.

Options and Accessories



Inline Attenuating Silencer



Attenuating Windband

Attenuating options – Reduce total sound levels without loss of discharge velocity. Tested as an assembly with fan housing.



Sure-Aire™ airflow monitoring – Without invasive probes, provides airflow measurement accuracy within 3%.

Stack extension – For projects that require additional discharge height or effective plume height.



Fan monitoring – Designed to allow facilities and maintenance the ability to stay connected with their critical ventilation products. The fan monitoring system package includes a preprogrammed monitor along with a wide selection of commonly applied sensors.



- Reduces unexpected downtime
- Assists with planned maintenance
- Monitors process and critical fan components
- Communicates with building automation systems

Pre-engineered Laboratory Exhaust Energy Recovery System (ERS)



Studies show that approximately 50% of the energy costs associated with operating a laboratory are the result of heating and cooling the make-up air. The addition of energy recovery can significantly reduce this cost.

In combination with the Vektor-M models, the ERS is designed to effectively recapture lost energy, remove contaminated laboratory exhaust and effectively dilute and disperse the exhaust effluent high above the roof.

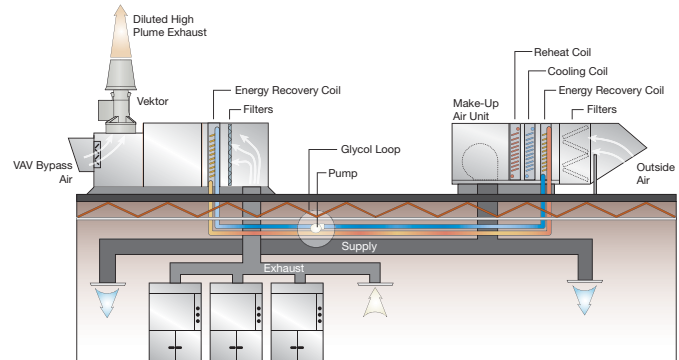

- Offers a safe and efficient solution with zero possibility of cross-contamination between exhaust and supply airstreams.
- Run around coil loops can achieve energy recovery efficiencies up to 50% to lower heating and cooling costs for the laboratory facility.
- Vektor energy recovery exhaust systems utilize run around coils to recover energy from the exhaust airstream and apply the energy to the make-up air system.

	Run Around Coil Loop Specifications
Type of Heat Transfer	Sensible
Sensible Effectiveness %	Up to 50%
Location of Exhaust/Supply Airstream	Separate
Cross-Contamination	None
Cross-Leakage	None
Temperature Range	-45° to 200°F

Increased Energy Savings AND Code Compliant with Vektor Variable Geometry Nozzle (VGN) Technology

Reducing airflow from a laboratory means less tempered supply air required to be made up, saving energy and reducing cost. With life safety laboratory exhaust fans there are unique requirements of minimum discharge velocity and preventing exhaust effluent re-entrainment

Vektor Variable Geometry Nozzle (VGN) Technology safely reduces the energy costs of the exhaust fans 50% or more based on the exhaust requirement within the VAV laboratory system.

- VGN technology automatically maintains discharge velocities and maximizes plume height as airflows from the laboratory vary.
- Works with building management system and a VFD to maximize energy savings in a VAV system reducing the horsepower requirements.
- Eliminate or reduce operating inefficiencies when using bypass air or sizing fans to maintain discharge velocity at minimum laboratory volume.

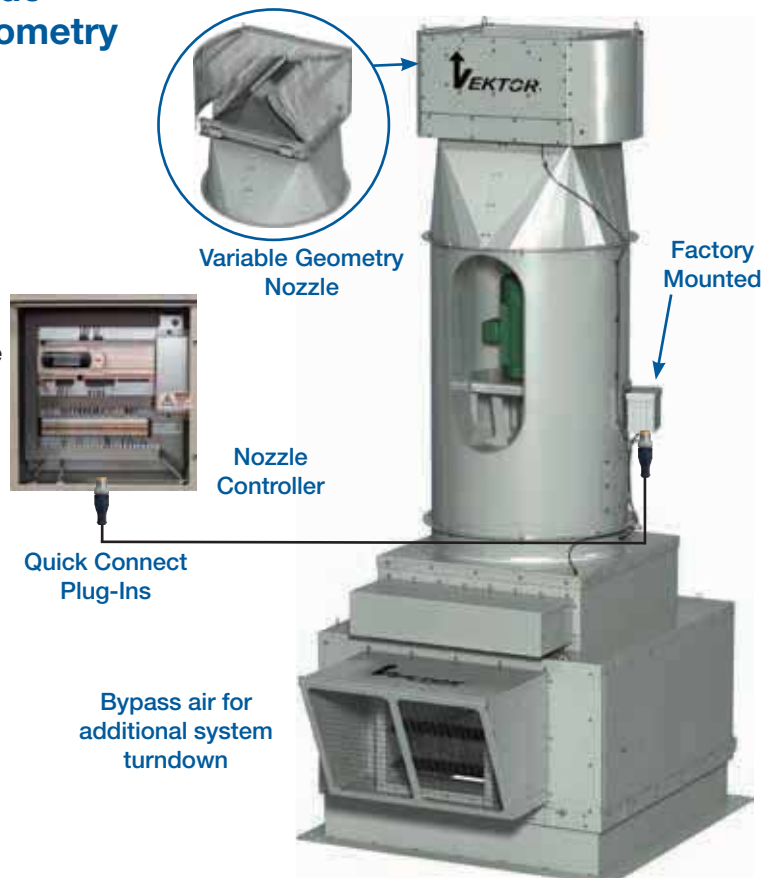

Plume Height Calculations – Chemical Emission and Odor Dispersion

The effective plume height is an important factor in designing exhaust systems servicing laboratories. The effective plume height needs to be high enough to avoid exhaust re-entrainment into the same or adjacent buildings. Fan discharge type, concentration levels and airflow volumes all affect the needed effective plume height. The effective plume height (h_e) is the physical height of the fan system (h_s) plus the plume rise (h_r).

ASHRAE 2015 Applications Handbook (Chapter 45) on laboratory design uses a geometric formula called momentum flux equation to calculate plume rise (h_r). The formula takes into account downwind distance, height of the building, prevailing wind speed and the terrain factor surrounding the building. Greenheck's CAPS® fan selection program does the calculations. Results can be compared to project requirements.

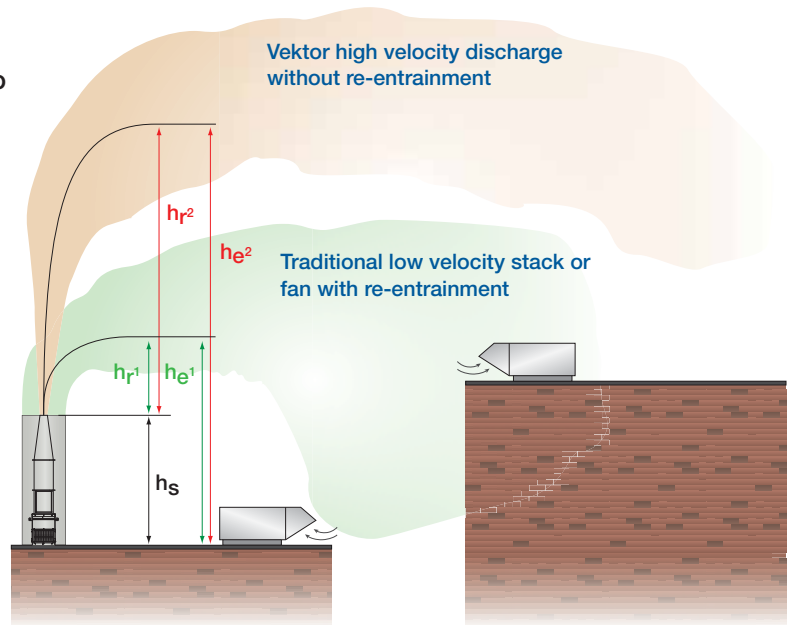

Design and Layout Information

CAPS® provides needed information for an informed decision and streamlines the design process.

- Size options presented for side-by-side comparison
- Sort sizes by criteria such as fan rpm, energy consumption, sound levels and effective plume height
- Full submittal information, drawings, weight, fan curves and component details, print, or PDF
- Revit® and scaled AutoCad® drawings are downloadable as configured.

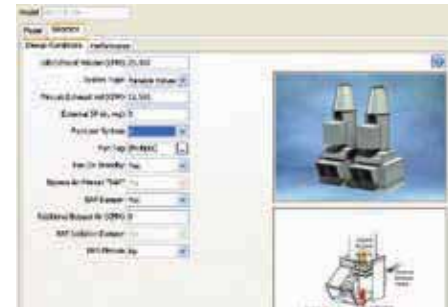

CAPS Configuration

Available Configurations

Fan Qty.	Fan Only	Inline	Side-by-Side
1	1	1 x 1	
2		2 x 1	
3		3 x 1	
4		4 x 1	2 x 2
5		5 x 1	
6		6 x 1	3 x 2



1x1 System

2x1 Inline System

2x2 Side-By-Side System

Model Number Nomenclature

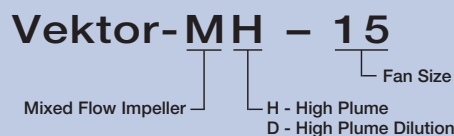

VEKTOR® Family of Lab Exhaust Systems

High Plume - Effective means of creating a discharge plume height to prevent re-entrainment of chemical exhaust fumes into make-up air systems.



Vektor-H

- High Plume Discharge Nozzle
- Centrifugal impeller
- Compact design / sealed airstream components
- Up to 26,000 cfm and 4 in. wg



Vektor-MH

- High Plume Dilution Nozzle
- Mixed flow impeller / bifurcated housing
- Compact design
- Up to 47,000 cfm and 11 in. wg



Vektor-CH

- High Plume Dilution Nozzle
- Centrifugal impeller
- Up to 56,000 cfm and 12 in. wg

High Plume Dilution - Fan design that entrains and mixes outside ambient air into the exhaust airstream prior to exiting out the windband discharge. Potentially hazardous exhaust or exhaust fumes is diluted and dispersed quickly.



Vektor-MD

- High Plume Discharge with Entrainment and Dilution
- Mixed flow impeller / bifurcated housing
- Compact design
- Up to 83,000 cfm and 11.5 in. wg



Vektor-CD

- High Plume Discharge Nozzle with Entrainment and Dilution
- Centrifugal impeller
- Highest efficiency / easy service design
- Up to 122,000 cfm and 13.5 in. wg

High Plume Variable Geometry Nozzle - Constant discharge velocity for variable volume applications. Discharge area changes to maintain constant discharge velocity and remain compliant to design codes. VGN maximizes effective plume heights during periods of reduced flow.



Vektor-HS

- Variable geometry discharge nozzle
- Variable volume flow – constant velocity discharge
- Centrifugal impeller
- Up to 26,000 cfm and 3.5 in. wg



Vektor-MS

- Variable geometry discharge nozzle
- Variable volume flow – constant velocity discharge
- Mixed flow impeller / bifurcated housing
- Up to 32,000 cfm and 10 in. wg



Vektor-CS

- Variable geometry discharge nozzle
- Variable volume flow – constant velocity discharge
- Centrifugal impeller
- Up to 32,000 cfm and 10 in. wg

Our Commitment

As a result of our commitment to continuous improvement, Greenheck reserves the right to change specifications without notice.

Specific Greenheck product warranties are located on greenheck.com within the product area tabs and in the Library under Warranties.



Prepared to Support Green Building Efforts

