

Vane Axial Fans

Models VAB and VAD

Belt and Direct Drive



 **GREENHECK**
Building Value in Air.

November
2019

Greenheck vane axial fans are designed for commercial and industrial applications where large volumes of air are required at moderate to high pressures. These fans are an excellent choice for HVAC systems using variable air volumes, clean rooms, parking garage exhaust, tunnel ventilations and other high volume requirements.

The tubular design, high efficiency rotor and integral straightening vanes provide high performance using minimal space. These fans can be mounted in a variety of configurations and are available with a complete line of accessories.



AMCA licensed air performance can be found in Greenheck's Performance Supplement for Vane Axial Fans.
00.CVI.NB004 R3
August 2011

Belt and Direct Drive Details

Specifications:	Belt Drive	Direct Drive
Fan Sizes	18-72	18-72
Hub Sizes	14, 17, 21, 26 and 30	14, 17, 21, 26 and 30
Capacities	2,000 – 145,000 cfm 3,400 – 246,400 m ³ /hr	1,200 – 240,000 cfm 2,000 – 407,800 m ³ /hr
Static Pressure	Up to 7.5 in. wg Up to 1,870 Pa	Up to 10 in. wg Up to 2,490 Pa

Model Number Code

The model number code consists of a number of separate elements that completely describe a vane axial fan for ordering purposes. The sequence of elements serves as a specifying and ordering checklist to ensure all elements are correctly identified.

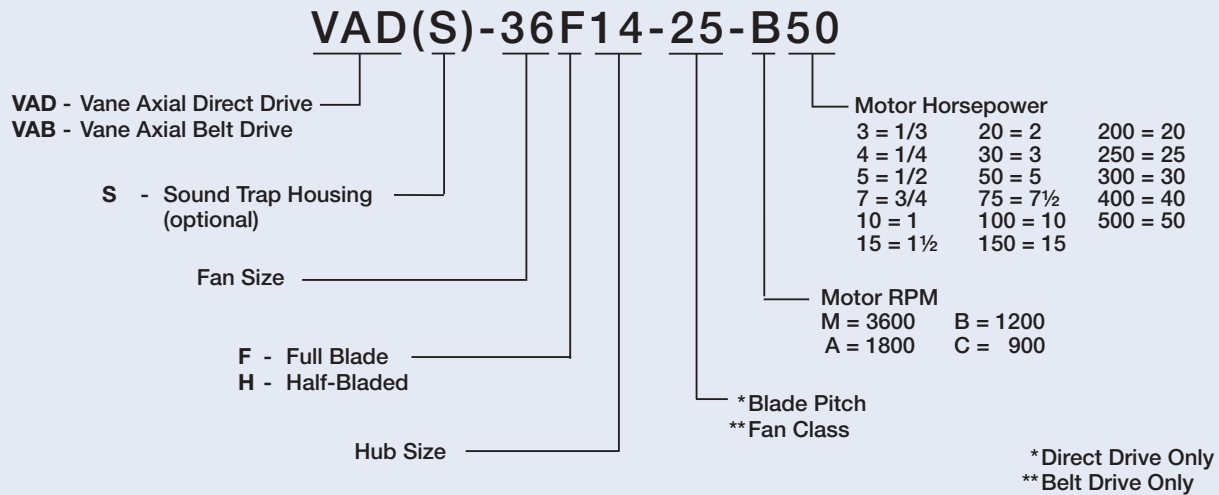

Leading Edge Support

All Greenheck products are supported by the industry's best product literature, electronic media, and two product selection tools - our Computer Aided Product Selection program (CAPS®) and eCAPS®, our online selection tool. Electronic copies of our product literature are found online as well as storage, installation and maintenance information in our Installation, Operation and Maintenance Manuals.

And of course, you can always count on the personal service and expertise of our national and international representative organization. To locate your nearest Greenheck representative, call 715-359-6171 or visit our website at www.Greenheck.com.



Belt Drive Models

Model VAB (Adjustable Pitch)

These models offer the advantages of final system balancing, easier access to the motor, economical future system upgrading, and the capability to operate in airstream temperatures up to 200°F (93°C).

Model VABS

This is an optional Sound Trap version of Model VAB for low sound applications.

Direct Drive Models

Model VAD (Adjustable Pitch)

Adjustable pitch fans offer low maintenance and compact size. Direct drive vane axials have a maximum operating temperature of 104°F (40°C) with standard motors.

Model VADS

The optional Sound Trap version of the VAD is also available. Sound Trap fans are designed for applications where low sound levels are required.

AIRFLOW →

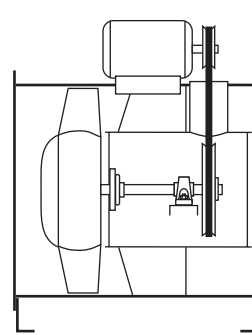

VAB

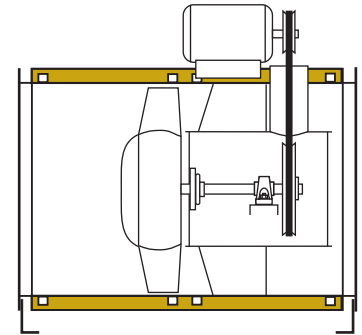

VABS with Sound Trap

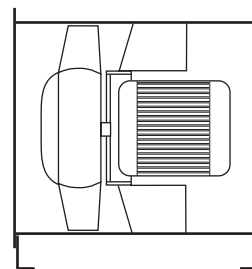

VAD

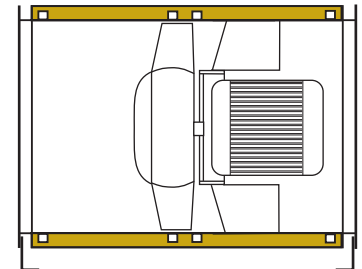

VADS with Sound Trap



Vibration Testing

Before shipment, every vane axial fan is vibration tested as a complete assembly. The maximum allowable vibration on a VAB/VABS at the fan bearings are 0.15 in/sec peak velocity, filter-in, for the specified fan RPM. VAD/VADS maximum vibration is 0.08 in/sec peak, filter-in, on the fan housing for the specified RPM. A record of any vibration test result is available upon request.

By performing the vibration test, we are able to provide more than simply trim balancing; it is also a diagnostic tool for finding potential problems. A defective bearing or motor, bent shaft or misaligned sheaves may cause excessive vibration. A complete vibration test will find these problems before the fan leaves the factory.

Electrostatic Powder Paint and Protective Coatings

All internal and external steel components are electrostatically powder painted prior to assembly with an industrial polyester urethane, Permator™. This finish is excellent for both indoor and outdoor applications and has added resistance to many common chemicals. An advantage of powder coatings is that they offer a uniform, durable and high quality finish that uses a one-coat process applied over a phosphatized surface. Charged paint particles are able to penetrate and fill voids in hard to reach locations like joints or mating pieces, areas often not covered by sprayed on wet paint. For increased chemical resistance or special applications, Greenheck offers a number of other powder coatings. Consult Greenheck's Product Application Guide, Performance Coatings for Ventilation Products for a complete listing of coatings and a relative resistance.



Drives

Premium cast iron sheaves are keyed to motor and fan shafts. Variable pitch motor sheaves can be adjusted to increase or decrease fan speeds (within horsepower and RPM limitations). Constant speed fixed pitch sheaves are also available and highly recommended for motors over 25 hp.

Shafts

Precision-ground and polished solid steel shafts are sized so that the first critical speed is at least 25% over the maximum operating speed.

Bearings

Standard bearings are air handling quality, grease lubricated, self-aligning ball or roller type, selected for a minimum (L₅₀) life in excess of 200,000 hours of operation at maximum cataloged conditions for each pressure class.

Extended Lubrication Lines

Pre-filled nylon lubrication lines extend from the fan shaft bearings to grease fittings on the exterior of the fan housing.

Motor Supports

Heavy gauge steel supports are welded to the fan housing. Motor plates with jack screws provide belt tension adjustment.

Motors

Heavy duty motors are carefully matched to the fan load. Greenheck can supply any voltage, phase or enclosure that is commercially available. Optional high efficiency motors are recommended for maximum energy savings.

Motor Mounting Positions

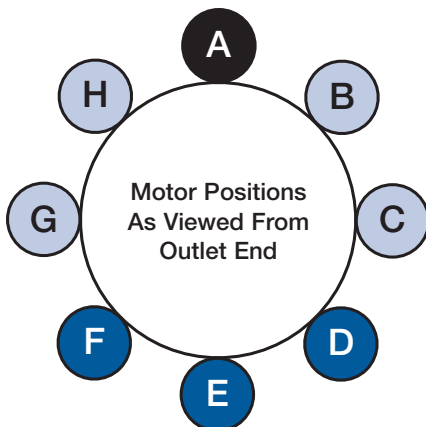

Standard motor position for horizontal ceiling hung and base mount.

Motor positions available for horizontal base mount.

Motor positions available for horizontal ceiling hung.

Note: Motor positions B, C, D, F, G and H require special consideration for sizing vibration isolators. Consult the factory. Motors on vertical mount fans are centered between the mounting brackets.

Extended Lubrication Lines

Pre-filled copper lubrication lines extend from each motor bearing to external grease fittings on the exterior of the fan housing.

Electrical

Leads from the motor are enclosed in a conduit and extended to the exterior of the fan housing. Leads terminate in an electrical junction box.

Rotors

Direct drive models are available with manually adjustable blade pitch. The adjustment of the preset-set blade pitch angle provides a means for system balancing during the installation or for future requirements.

Motors

Direct drive vane axial motors have an advantage of being located in the airstream and are cooled by the airflow. Greenheck can supply standard or high-efficiency motors of any voltage, phase or enclosure commercially available. Check motor frame size limitations in the Vane Axial Performance Data brochure when making selections.

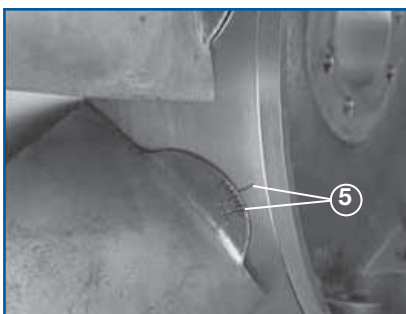
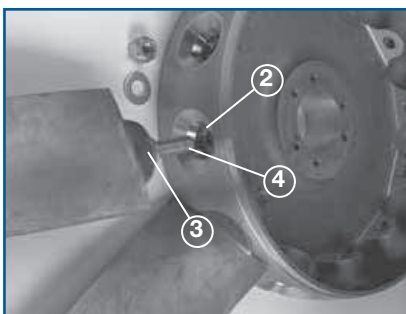

Rotor Construction Features

1. Hub and blades are constructed of aircraft quality heat treated A356-T6 cast aluminum.
2. Blade sockets are precision machined into the rotor hub.
3. Blade bases are precision machined for an exact fit.
4. Steel blade studs are threaded into the blade base and secured to the rotor hub with self-locking nuts.
5. One blade base is stamped with blade pitch graduations and indexed to the hub. All blades can be field adjusted (within horsepower limitations) using this master blade as a reference.

Half-Bladed Construction

Models with half-bladed rotors offer higher efficiency at lower pressures using half the standard number of blades.

Greenheck's Sound Trap housing is unique in the air movement industry.

With floor space at premium prices in the building industry, eliminating costly add-on silencers has a two-fold benefit. First, conventional acoustical silencers add considerable length to the unit and are ineffective for reducing sound radiated from the fan housing. Secondly, add-on silencers reduce air performance by adding additional static pressure to the system. In critical applications, this may increase brake horsepower and result in a larger motor requirement.

Greenheck's Sound Trap housing increases the fan length only slightly to reduce sound transmitted from the inlet and outlet. No additional pressure drop is experienced using the Sound Trap housing. The Sound Trap housing is available on all Greenheck vane axial fans, direct or belt drive.

Typical Sound Power Attenuation

Greenheck Sound Trap construction effectively reduces inlet and outlet sound power levels in each of the eight octave bands as shown below.

Octave Band	1	2	3	4	5	6	7	8
dB Reduction	0	-3	-7	-10	-10	-7	-7	-1

Conventional vane axial with silencers compared to Greenheck's Sound Trap design.

Costly and bulky add-on silencers take up valuable floor space, create additional pressure losses and hinder service access to vane axial components located at the inlet and outlet. Since sound absorbing materials are located prior to the inlet and downstream from the outlet, no sound attenuation is provided for sound radiated through the fan housing.

Greenheck's Sound Trap fan construction adds just a few inches to the fan length. This additional length provides sound attenuation between the rotor and fan inlet, reducing sound transmitted from the inlet. Radiated sound is effectively reduced by the Sound Trap fan housing.

Construction Features

- A. A perforated steel inner liner directs sound waves into sound absorbing material between the inner liner and solid steel outer shell converting acoustical energy to heat.
- B. Two inches of sound absorbing fiberglass is sandwiched between the inner and outer shell. The fiberglass meets requirements of NFPA 90A and 90B, and ASTM C 1071 Type I. The liner meets all requirements for 25 flame spread or 50 smoke development when tested in accordance with ASTM-E84, UL-723 and NFPA-255.
- C. Steel bands seal the insulated cavity against pressure loss.

Sound Trap housing provides no additional pressure drop when compared to standard vane axial housings.



Conventional vane axial with add-on silencers



Greenheck's exclusive Sound Trap Vane Axial

Horizontal Mounting Legs

Heavy gauge steel support legs welded to the fan are punched to accept base vibration isolators.



Horizontal Suspension Brackets

Brackets welded to the fan housing for horizontal ceiling hung applications are punched to accept hanging spring isolators.



Vertical Base or Suspension Brackets

Brackets welded to the fan housing for vertical base mount or vertical ceiling hung applications are punched to accept vibration isolators. Customer must specify one of the mounting arrangements shown below.

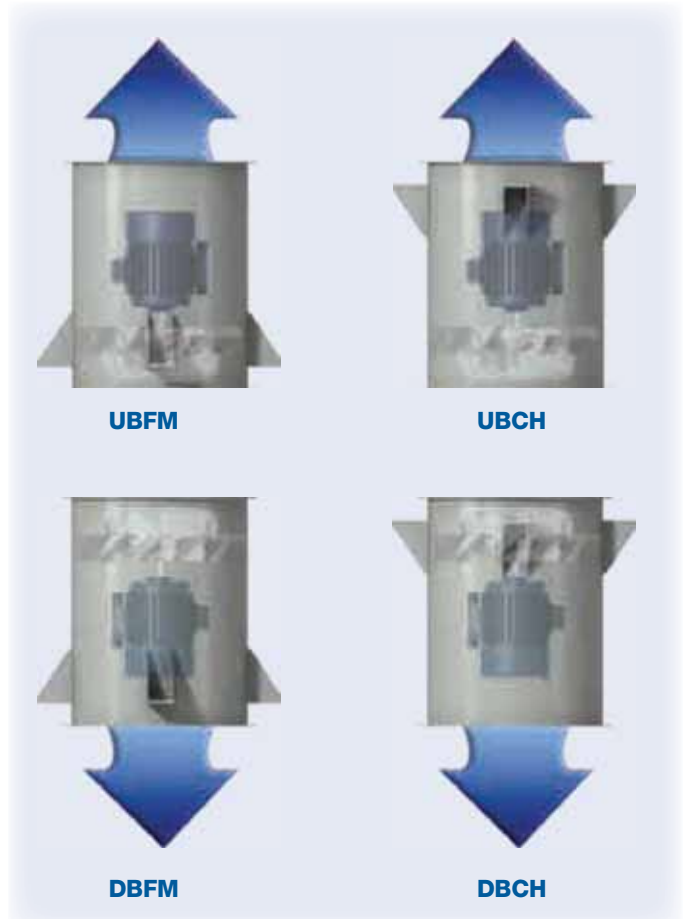

The VAB/VABS and VAD/VADS are available with optional accessories to improve the ease of installation, enhance performance and provide safety during operation. Accessories supplied by Greenheck conform to our high standards of quality.

Companion Inlet and Outlet Flanges

Available to aid the connection of the fan casing flange to ductwork. Companion flanges are prepunched to match the bolt hole dimensions.

Inlet Bell

Minimizes entry losses into the fan from free (non-ducted) inlet conditions to ensure rated performance. Inlet bell guards are supplied to prevent accidental contact with the fan propeller.

Inlet and Outlet Guards

Protect personnel and equipment in ducted or non-ducted installations. Guards are heavy gauge expanded steel and are removable for routine fan maintenance.

Inspection Section with Access Door

Highly recommended to provide access to internal fan components of ducted fans when inlet or outlet cones are not installed. The bolted access door allows visual inspection only. Hinged access doors are available.

Inlet/Outlet Cone

Recommended on all ducted and non-ducted outlets with high velocities. Provides higher fan efficiency by allowing gradual expansion of high velocities converting energy-wasting velocity pressure into usable static pressure. Inlet and Outlet cones are available with bolted access doors for visual inspection.

Guard for Inlet/Outlet Cone

Expanded steel screen sized for the large end of an outlet cone. Recommended for all non-ducted inlets and outlets.

Belt Guard

Three-sided or totally enclosed belt guards protect motor pulley and drive belts, as well as personnel from rotating drive components. Cannot be used when a motor cover is installed.

Motor Cover

A vented steel cover installed over the motor and drive on belt drive units provides protection from weather, dust and dirt while protecting personnel from rotating drive components.

Isolators

Both base mount and hanging style are available in spring mounts. The isolators are furnished in sets of four and are sized to match the total weight of each fan, motor and accessory combination.

Vibration Switch

This is an adjustable switch that shuts the fan off immediately in event of excessive vibration. The switch can be preset to any level of vibration amplitude and provides continuous vibration monitoring. An audible or visual signal may also be wired to the switch. Designed for maintenance free service in permanent installations.

Thrust Restraints

Recommended on installations where the fan thrust-to-weight ratio may result in fan movement. Thrust restraints are typically installed in pairs at the fan discharge.

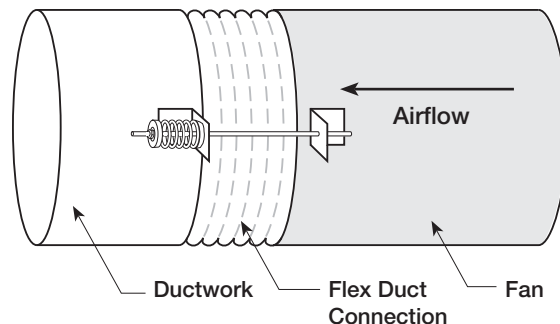

**Thrust Restraint
Installation (Typical)**

Electrical Wiring Options

Electrical wiring is standard on VAD/VADS fans and brings the electrical connections from the motor to the exterior of the fan casing. **Extended Motor Leads** are an extension of the actual motor wires from within the motor housing to an externally mounted junction box on the fan casing. **Extended Wiring** can be provided to route electrical leads from the standard motor junction box to the exterior of the fan casing. In both cases the leads are enclosed in a protective conduit.

Exploded View (Belt Drive)

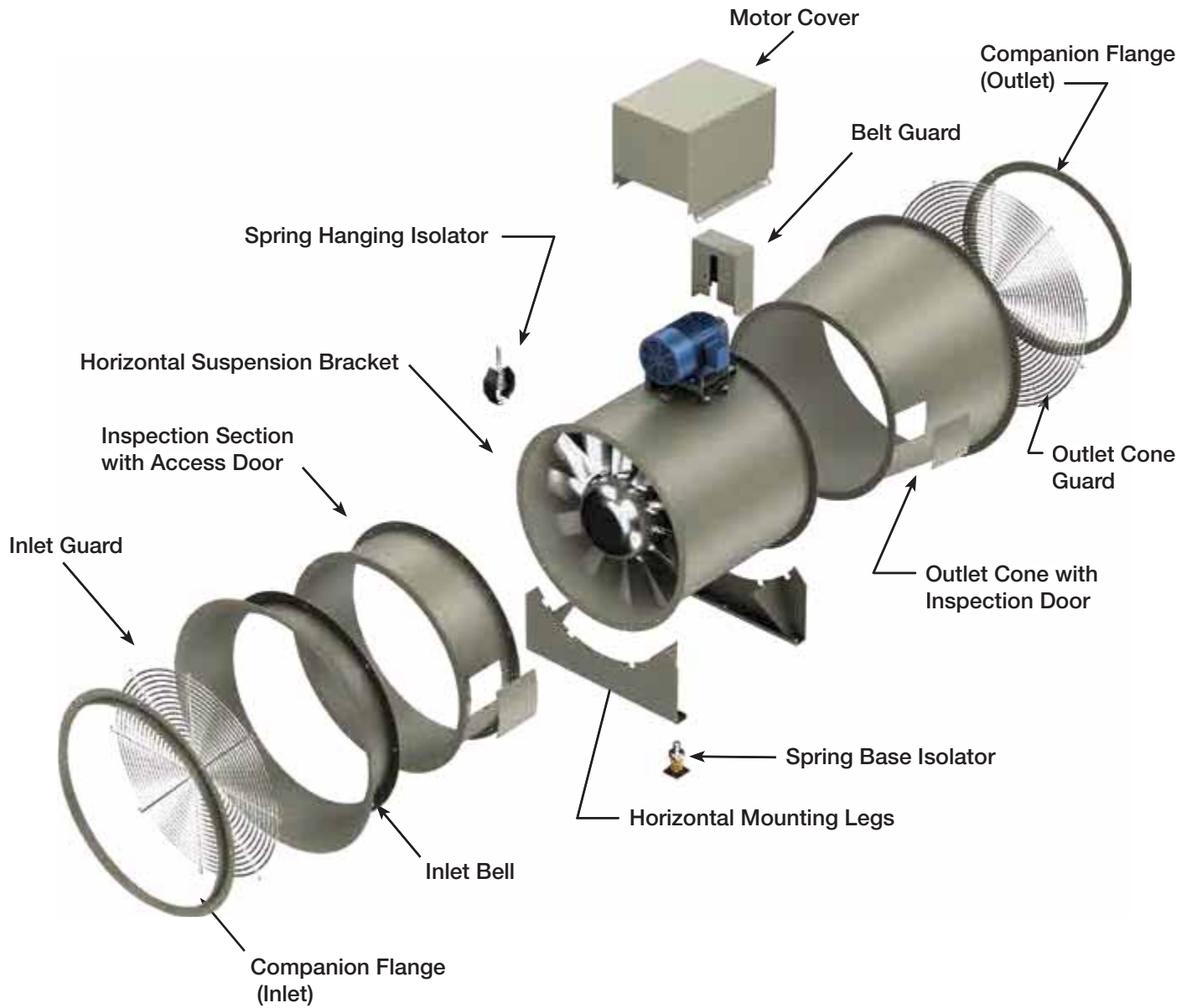

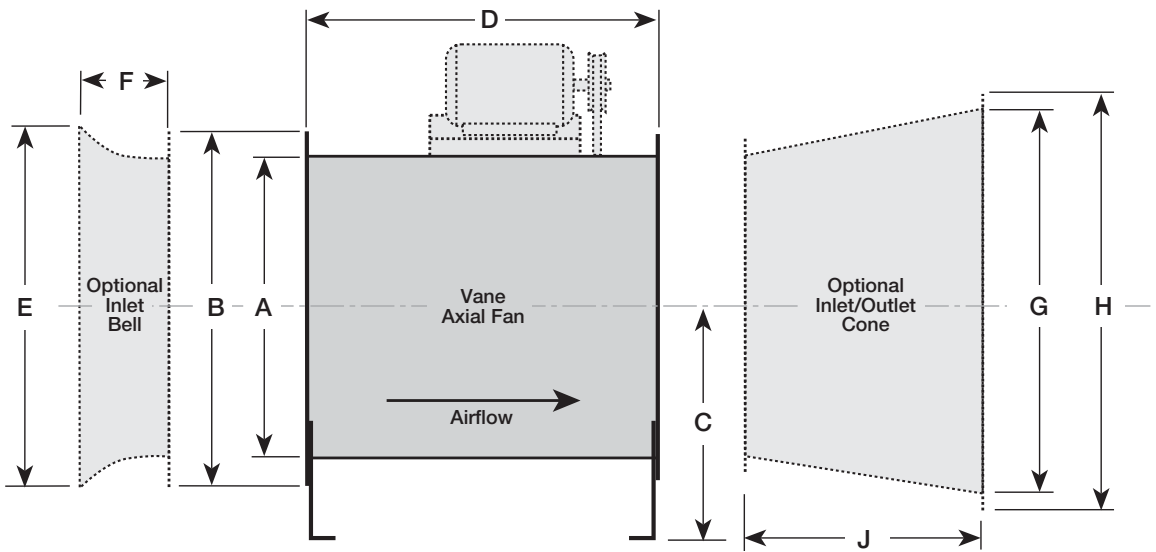

Fan Size	A	B	C	D	E	F	G	H	J	K	L (inches sq.)
18	18 ³ / ₈	21 ³ / ₄	13 ¹ / ₂	SEE CHART BELOW	23 ¹ / ₂	4 ¹ / ₂	23	26 ¹ / ₄	16	14	7
20	20 ³ / ₈	23 ³ / ₄	15		26	4 ³ / ₄	25	28 ¹ / ₄	18	14	7
24	24 ³ / ₈	27 ³ / ₄	17 ¹ / ₂		30	5 ³ / ₄	30 ³ / ₈	33 ¹ / ₂	21	14	7
30	30 ³ / ₈	33 ³ / ₄	21 ¹ / ₄		36	6 ⁵ / ₈	36 ³ / ₈	39 ¹ / ₂	26	14	7
36	36 ³ / ₈	39 ³ / ₄	25		46	8 ¹ / ₂	44	47 ¹ / ₄	31	14	7
42	42 ¹ / ₂	47	29		54 ⁵ / ₈	10 ¹ / ₂	52	56 ¹ / ₄	36	17	10
48	48 ¹ / ₂	53	34		60 ⁵ / ₁₆	11 ¹ / ₂	61 ¹ / ₄	66 ¹ / ₂	42	17	10
54	55	59 ¹ / ₂	37		68	12	67 ¹ / ₄	72 ¹ / ₂	47	22	15
60	61	66 ¹ / ₂	41		78	14 ¹ / ₄	75	80 ³ / ₈	52	22	15
66	67	72 ¹ / ₂	44 ¹ / ₂		85	15 ³ / ₄	82	88 ³ / ₈	57	22	15
72	73	78 ¹ / ₂	48 ¹ / ₂		93	17	89	95 ³ / ₈	62	22	15

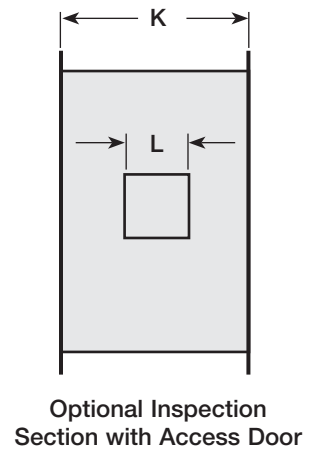

Dimensions shown are in inches. For direct drive fans, Dimension D varies with motor frame size.

D Housing Length

Fan Size	Direct Drive					Belt Drive	Sound Trap
	Adjustable Pitch – VAD						
	182T - 215T	254T - 286T	324T - 365T	404T - 405T	444T - 445T	VAB	VADS VABS
18	32	36	-	-	-	32	40
20	32	36	-	-	-	32	44
24	32	36	40	-	-	36	48
30	32	36	40	-	-	40	52
36	32	40	44	48	52	40	56
42	32	40	44	48	52	44	61
48	32	40	44	48	52	48	65
54	32	40	44	48	52	48	69
60	-	40	44	48	52	52	73
66	-	40	44	48	52	52	77
72	-	40	44	48	52	52	80

Dimensions shown are in inches.

Fan Weights (lbs.)

Fan Size	Direct Drive – VAD					VAB	VADS	VABS	Housing Material Thickness
	182T - 215T	254T - 286T	324T - 365T	404T - 405T	444T - 445T				
18	169	181	-	-	-	213	342	385	10 ga.
20	189	200	-	-	-	237	398	446	10 ga.
24	239	254	268	-	-	419	508	575	10 ga.
30	334	352	369	-	-	477	691	799	10 ga.
36	473	597	627	656	685	776	1050	1230	3/16 inch
42	626	703	737	772	805	942	1290	1490	3/16 inch
48	730	833	872	911	949	1190	1550	1830	3/16 inch
54	-	1220	1280	1340	1400	1830	2140	2630	1/4 inch
60	-	1370	1440	1510	1580	2160	2490	3070	1/4 inch
66	-	1470	1550	1620	1700	2360	2790	3460	1/4 inch
72	-	1690	1780	1860	1940	2690	3190	3930	1/4 inch

Motor Weights (lbs.)

Motor Frame Size	Open	TEFC
143T	30	50
145T	38	54
182T	58	90
184T	84	110
213T	110	163
215T	136	193
254T	247	251
256T	300	306
284T	358	362
286T	387	409
324T	469	520
326T	516	583
364T	595	864
365T	643	968
404T	847	1091
405T	942	1222
444T	1145	1606
445T	1380	1880
447T	1748	2950

Accessory Weights (lbs.)

Fan Size	Inlet Bell	Inlet/Outlet Cone	Inlet/Outlet Guard	Belt Guard	Motor Cover	Inspection Section	Horizontal Base	Vertical Brackets	Horizontal Ceiling Hung Brackets
18	10	38	9	5	29	33	20	33	6
20	11	44	11	5	29	36	22	33	6
24	13	58	14	7	42	43	27	33	6
30	24	82	17	10	54	54	33	33	6
36	33	146	22	11	64	64	60	33	10
42	53	205	32	13	64	112	92	33	10
48	64	268	39	14	64	128	147	46	10
54	80	408	46	17	76	178	176	46	16
60	191	507	60	20	76	197	199	46	16
66	208	603	69	22	76	217	237	46	16
72	249	695	78	23	76	236	261	46	16

Rotor Blades per Hub Size – Full Bladed Hubs

Hub Size	14	17	21	26	30
Number of Blades	8	10	12	14	16

Specifications

Belt Drive

Vane axial fans shall be belt driven, Arrangement 9, with the motor attached to the exterior of the fan housing on an adjustable base. Turned, precision ground and polished steel shafts shall be sized so the first critical speed is at least 25% over the maximum operating speed. Bearings shall be grease lubricated, air handling quality ball or roller type selected for a minimum average (L₅₀) life in excess of 200,000 hours at maximum operating speed. Rotor blades and hub shall be heat treated cast aluminum alloy A356-T6 with blade bases and hub sockets precision machined. Blades shall be attached to the hub with steel studs and self-locking nuts. Hub shall be positively secured with a steel taper lock bushing keyed to the fan shaft. Rotor blade pitch shall be manually adjustable within horsepower limitations. Rotor shall be statically and dynamically balanced to within 0.0785 in./sec. peak vibration velocity as measured on the bearings. Fan housing shall be fabricated from heavy gauge steel with prepunched flanges at both ends. A minimum of seven heavy gauge straightening vanes shall be welded to the fan housing downstream from the rotor. (For optional Sound Trap construction insert the last paragraph). Vane axial fans shall be model VAB or VABS (select one) as manufactured by Greenheck Fan Corporation of Schofield, Wisconsin, and shall be supplied as shown on the plans and in the fan schedule.

Direct Drive

Vane axial fans shall be direct driven, Arrangement 4, with the fan rotor secured to the motor shaft. Motors shall be located downstream from the rotor for maximum cooling. Rotor blades and hub shall be heat treated cast aluminum alloy A356-T6 with blade bases and hub sockets

precision machined. Blades shall be attached to the hub with steel studs and self-locking nuts. Hub shall be positively secured with a steel taper lock bushing keyed to the motor shaft. (Add paragraph for appropriate rotor type here). Rotor shall be statically and dynamically balanced to within 0.0785 in./sec. peak vibration velocity as measured on the fan housing. Fan housing shall be fabricated from heavy gauge steel with prepunched flanges at both ends. A minimum of seven heavy gauge straightening vanes shall be welded to the fan housing downstream from the rotor. (For optional Sound Trap construction insert paragraph below here). Vane axial fans shall be model VAD or VADS (select one) as manufactured by Greenheck Fan Corporation of Schofield, Wisconsin, and shall be supplied as shown on the plans and in the fan schedule.

Adjustable Pitch Rotor

Blades shall be manually adjustable within horsepower limitations. A blade tip angle scale shall be machined into the base of the master blade and indexed to the hub. All blades shall be adjustable to align with the master blade pitch setting.

Sound Trap Construction

When specifying optional Sound Trap construction add the following in the locations noted above: fan construction shall be double-walled with two inches of sound absorbing material between the walls. The inner wall shall be constructed of perforated steel. Air performance ratings shall be equal to equivalent size fans with a single wall housing.



Our Commitment

As a result of our commitment to continuous improvement, Greenheck reserves the right to change specifications without notice.

Product warranties can be found online at Greenheck.com, either on the specific product page or in the literature section of the website at Greenheck.com/Resources/Library/Literature.

