



The Stancor Oil-Minder® Duplex Control and Pumps System is designed and approved for safe operation of pumping, alarming and monitoring of elevator sump pits, transformer vaults and other applications where oil and water must be detected.

The Stancor Oil-Minder® Duplex system will activate the pumps to remove water from elevator pits in accordance with ASME A17.1, and will provide pumping of water only, even if an oil condition is detected.

The Stancor Oil-Minder® Duplex cycles the pumps only in the water range. Oil and other harmful substances are not discharged into the environment. An alarm is activated in the event of a high water condition or high oil condition.



Oil-Minder® Description of Operation

As the liquid level rises in the sump, the pump ON float starts the pump provided the sensor probe detects water. The pump runs until the liquid level drops and the probe no longer senses water. Any oil layer will not be pumped out of the sump. If the water level rises in the sump and reaches the high alarm float, pump B and an alarm is activated. The pumps will continue to run until the liquid drops back to the minimum level. If the sensor detects oil, the pumps will stop and the oil will be contained. The Stancor Oil-Minder® Duplex Control and Pumps System are designed to alternate pumps, to prevent wear on one single pump.

Features:

- NEMA 4x weathertight corrosion resistant polycarbonate enclosures
• Stainless Steel sensor probe with patented electronic technology that repels dirt contamination.
• Single direct plug-in power source for operation of entire system.
• Solid state components.
• Alarms, lights, silence switch, and remote monitoring circuit for oil, high liquid, and high amperage conditions as well as many custom options are available.
• Complete factory assembly and testing insures quality of entire pump and control system.
• Patented - Pat. #4,715,785, #4,752,188, #6,203,281 and others pending.
• Oil-Minder® Duplex System can be combined with a variety of different pumps and valves.
• 115V, 208V or 220V (1 phase).
• 208/230V or /460/575V (3 phase).
• LED indicator lights for oil spill, power, high liquid level, overload and pumps run.
• UL 508 and 778 approved.
• Compliant with ASME A17.1 Elevator Code.

Performance Curve

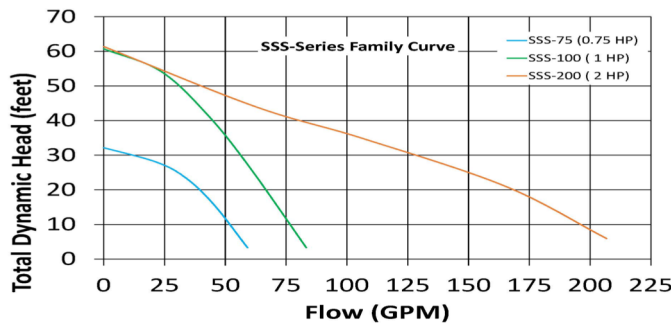

Electrical Data

Table with 10 columns: Model, Phase, BHP, Volts, FLA, LRA, NEMA Letter, Pole/Speed (rpm), Pump Weight, Discharge. Rows include SSS-75, SSS-100, and SSS-200 configurations.



Construction

Motor Design	Induction	Motor Housing	Stainless Steel
Motor Type	Enclosed submersible	Volute	Stainless Steel
Insulation Class	Class B	External Hardware	Stainless Steel
Motor Protection	Bi-metallic Thermal Switch	O-Rings	Nitrile (Buna N)
Bi-Metallic Temp Trip	120° C ± 5° C	Motor Shaft	Stainless Steel
Max Fluid temp	104°F (40°C)	Impeller	Stainless Steel
Upper Shaft Seal	carbon/ceramic	Lower Shaft Seal	Sic/Sic

Configurations

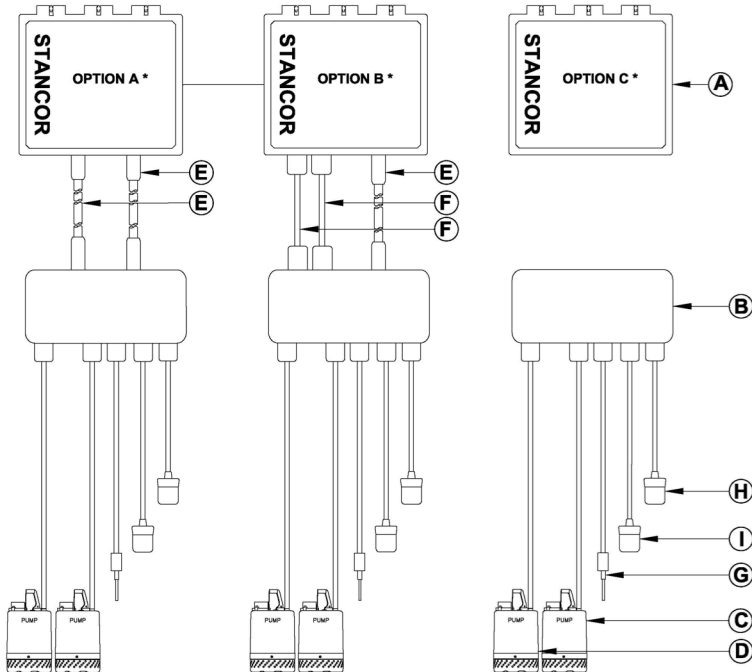

Item	Description
A	Control Panel
B	J-Box
C	Pump A
D	Pump B
E	8 Pin Cable
F	Pump Power Cable
G	Sensor Probe
H	High Float
I	ON Float

* See OM Configuration Sheet for specific option

Installation Dimensions

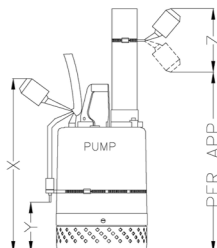
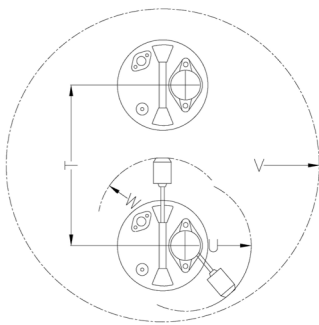

Item	Description
T	Min. Fitting Dist.**
U	High Float Radius
V	Min. Sump Ø
W	ON Float Radius
X	Pump ON
Y	Pump OFF
Z	High Alarm

* See OM Configuration Sheet for specific option and dimensions.

**Fitting dimensions are based on ANSI/ASME B16.3 standards.