

RoughDeck® PW-1 Stainless Steel

Low-profile Pallet Weighing Floor Scale

Specifications

End Load Capacity:
80% full scale at 2,500 lb
100% full scale at 5,000 lb

Cable Length:
20 ft (6.1 m) for connecting junction box to indicator

Warranty:
Load cells two years, all other components one year

Standard Features

- Low-profile design
- 20 feet SURVIVOR® EL147HE hostile environment load cell cable
- Top-access junction box
- TuffSeal JB4SS stainless steel, NEMA Type 4X junction box with signal trim card
- Four adjustable stainless steel SUREFOOT™ support feet
- Four stainless steel, IP66 shear beam load cells



APPROVALS



Part Number/Price

Part #	Size (W x L x H)	Capacity	Est. Weight	Price
177910	48 in x 48 in x 3 in	2,500 lb	200 lb	\$3,500.00
177911	48 in x 60 in x 3 in	2,500 lb	210 lb	\$3,700.00
177912	60 in x 60 in x 3 in	2,500 lb	235 lb	\$3,900.00
177913	48 in x 48 in x 3 in	5,000 lb	200 lb	\$3,500.00
177914	48 in x 60 in x 3 in	5,000 lb	210 lb	\$3,700.00
177915	60 in x 60 in x 3 in	5,000 lb	235 lb	\$3,900.00

Options/Accessories

Part #	Description	Price
18778	Floor anchor plates, stainless steel (set of 2)	\$45.00
28740	RoughDeck floor stand for indicator, 36.3 in high, stainless steel	\$310.00
178250	Wheel kit option	\$95.00
Consult	Stainless steel deck with RL32218S-HE hermetically sealed IP69K stainless steel cFMus approved load cells and hardware	+\$320.00 list price add-on

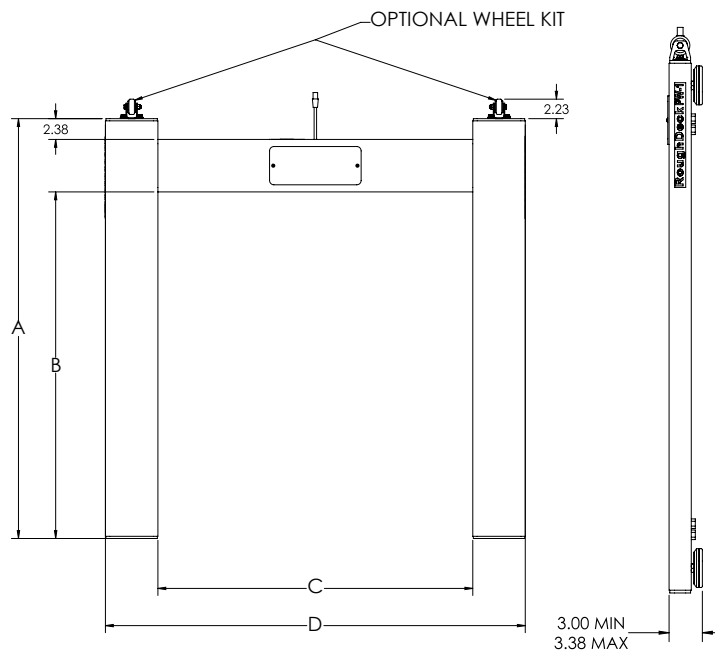

Dimensions	
4 ft x 4 ft (160 lb)	
A	48.00 in
B	39.63 in
C	36.00 in
D	48.00 in
4 ft x 5 ft (170 lb)	
A	48.00 in
B	39.63 in
C	48.00 in
D	60.00 in
5 ft x 5 ft (195 lb)	
A	60.00 in
B	51.63 in
C	48.00 in
D	60.00 in