

Bello Zon® Series

“Chlorine-Free” Chlorine Dioxide (ClO₂) Generation



Chlorine Dioxide is an environmentally friendly, economical, and highly effective disinfectant and oxidant. Chlorine Dioxide offers (compared to widely used Chlorine) a large range of advantages for the disinfection of drinking and process waters.

ProMinent® Bello Zon® generators provide reliable and maintenance-reduced production and metering of chlorine dioxide under the highest safety standards. Optimally tuned systems for water disinfection can be designed with **Dulcometer®/Dulcotest® analyzers** for corresponding measurement or control technology.

Features & Benefits

- More than 30 years of experience with ClO₂
- More than 8000 units installed globally!
- Safe, on-site generation: No need to store or transport dangerous chemical disinfectants!
- Proven two-chemical design: Hydrochloric acid and Sodium chlorite - chlorine free operation
- Flow proportional generation allows operator to dial in required feed rate in ppm
- New PVDF Reactor
- Safety features provide automatic generator shutdown upon alarm condition
- Integrated PID Control
- Data Logger and Screen Recorder
- Direct Monitoring of ClO₂ and Chlorite

Applications

- Disinfection
- Odor removal
- Municipal drinking water
- Legionella control
- Industrial wastewater treatment
- Metal oxidation
- Bottle Washing
- CIP Systems
- Cooling Towers
- Vegetable and Fruit Washing

Bello Zon® Series

Capacity data

Capacity Data								
Model	Capacity	Max Pressure	*Chemical Usage	Temp	Dimensions	Weight	Voltage	Current Draw
	(Lbs/day)	(psi)	(gal/day)	(°F)	(HxWxD)	(lbs)	(volts)	(amps)
CDV								
CDVc 20	1	116	3.2	50-104	53"x40"x8"	57	115	1
CDVc 45	2.4	116	7.1	50-104	53"x40"x8"	59	115	1
CDVc 120	6	116	19	50-104	53"x40"x8"	62	115	1
CDVc 240	13	116	38	50-104	53"x39"x10"	99	115	1.2
CDVc 600	31	116	95	60-104	67"x47"x11"	165	115	1.4
CDVc 2000	106	73	317	60-104	75"x55"x15"	264	115	3.2
CDK								
CDKc 150	8	116	43	50-104	55"x35"x13"	187	115	9.5
CDKc 400	21	116	120	60-104	67"x38"x18"	253	115	5.1
CDKc 900	48	116	310	60-104	79"x41"x20"	286	115	13.8
CDKc 2000	105	73	864	60-104	79"x48"x22"	429	115	12.8
CDKc 2800	146	73	864	60-104	79"x48"x22"	429	115	6.7
CDKc 7300	384	44	2314	60-104	90"x60"x22"	475	115	6.7
CDKc 12000	636	29	4248	64-104	90"x60"x22"	475	115	6.7

*Volumes are total of each precursor

Designs to Fit Your Application

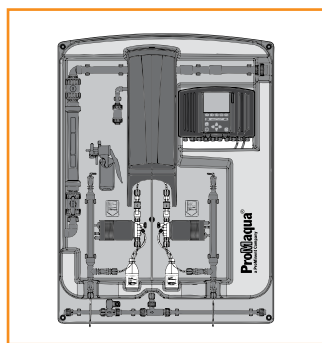

Bello Zon® CDVc 20-240

Precursors: 9% HCl and 7.5% Sodium Chlorite
Capacity Range: 0.25 lbs/day to 13 lbs/day

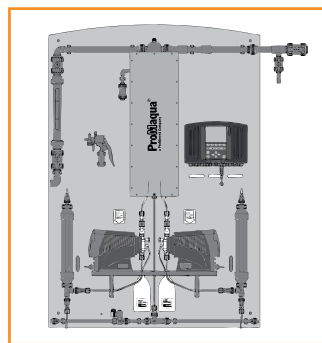

Bello Zon® CDVc 600-2000

Precursors: 9% HCl and 7.5% Sodium Chlorite
Capacity Range: 0.75 lbs/day to 106 lbs/day

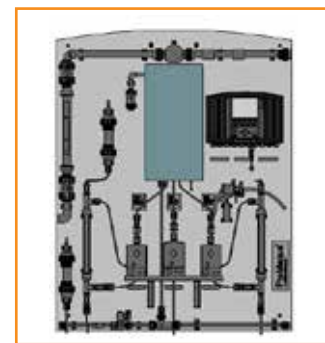

Bello Zon® CDKc

Precursors: 30-33% HCl and 25% Sodium Chlorite
Capacity Range: 9 lbs/day to 634 lbs/day



ProMinent Fluid Controls, Inc.
136 Industry Drive • Pittsburgh, PA 15275 USA
(412) 787-2484 • Fax: (412) 787-0704
email: sales@prominent.us • www.prominent.us

© 2018 ProMinent Fluid Controls, Inc. All Rights Reserved.

PN: 7750236
BelloZon.indd rev4 10/02/2018