

NEW 350-10-3M Dual-ramp Wheelchair Scale

Metal Platform

Specifications

Capacity:

1,000 lb x 0.2 lb (450 kg x 0.1 kg)

Platform Dimensions:

(W x L x H) 31.5 in x 29.5 in x 3.15 in

Power:

9VDC, provided by six AA alkaline batteries (included) or AC adaptor (optional)

Battery Type:

Six AA alkaline (included)

Battery Use:

25 hours continuous use with batteries
Automatic power-off can be configured

Operating Temperature:

50° F to 104° F (14° C to 40° C)

Display:

5-digit LCD display, 0.75 in (1.9 mm) digit height

Approvals:

c-Met, E113986

Warranty:

Two-year limited warranty



Model 350-10-3M



Wheelchair scale in folded position

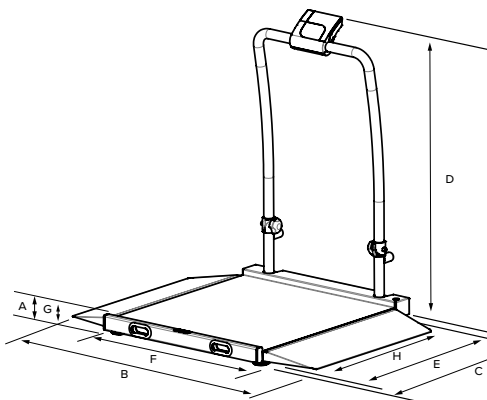

Standard Features

- Metal platform with slip resistant surface
- Dual ramp for on/off access
- Integrated wheels for easy transport
- Large, stable scale base
- Push-button LCD display
- BMI (body mass index) function
- Hold function
- Ability to manually enter the tare weight of additional items, such as a wheelchair or oxygen tank
- Units of measure: lb only, kg only, lb/kg
- Motiontrap™ movement compensation technology
- EHR capable

Part Number/Price

Part #	Model #	Capacity	Price
193956	350-10-3M	1,000 lb x 0.2 lb (450 kg x 0.1 kg)	\$1,933.00

Shipping Weight

Part #	Model #	L (in)	W (in)	H (in)	Package Wgt. (lb)	Dim Wgt. (lb)	Shipping Wgt. (lb)
193956	350-10-3M	51	42	14	102	216	216

Options/Accessories

Part #	Description	Price
115655 †	9 VDC adaptor, 120 V/230 V auto switching c-MET medical grade power supply	\$33.00
133077 †	9 VDC adaptor, 120 V/230V auto switching	\$15.00
102508 ††	9 VDC adaptor, 230 V	\$20.00
81076	Epson TM-U220 tape printer	\$420.00
186830	Printer cable, 25-pin D-Sub male to RJ-45, 6 ft	\$65.00

Dimensions

	Inches	Centimeters
A	3.15	8.0
B	47.7	121
C	37.8	96
D	45.3	115
E	31.5	80
F	29.5	75
G	2.4	6
H	27.2	69



† NEMA 1-15 Plug

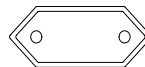

†† CEE 7/16 Plug