

Minebea Intec Contego-Hygienic Weigh Module Kits

Top Cable Outlet



Junction Box not shown

The protective cover made of FDA-compliant silicone ensures a reliable encapsulation of the module and prevents the intrusion of dirt and microorganisms. The connecting geometry between protective cover and mounting plates guarantees a safe fitting and, together with the already excellent resistance to aging of the silicone, ensures reliable protection over years.

The Contego® weighing module therefore represents an absolutely hygienic unity of load cell and installation kit. As a result, you can refrain from using other expensive and complicated constructions to protect the weighing technology against dirt.

Besides the hygienic aspect, the Contego weighing module provides all the other important mechatronic functions for a fast operational startup and reliable results. The integrated constraint holds the process vessel in the proper position and, at the same time, allows movement through thermal expansion of the vessel. The integrated lift-off protector is a reliable safety feature to protect the vessel from tilting. At the same time, this feature can be used as a lifting system as well. This way, the vessel leg can be raised a few millimeters without using supplemental tools.

A PR6241 S-type load cell is used with this module. This series is distinguished by its unmatched reliability, robustness and stability, enabling years of undisturbed usage without any readjustment, in addition to the high measuring accuracy and reproducibility.

Standard Features

- Compact and absolute hygienic weighing solution for a load range up to 2 t
- Quick and seamless installation
- Easy cleaning without residue High chemical resistance
- Protective cover made of FDA-compliant silicone
- Integrated S-like lift-off protector and jack-up function with constrainer for horizontal forces
- Proven rocker pin principle for accurate repeatability
- 10,000 divisions
- Load cell, 2 mV/V
- 15-year load cell warranty
- 30 kN destructive lateral force and 8 kN permissible lift-off protection

LOAD CELL CERTIFICATIONS



Options/Accessories

Part #	Type	Minebea Part #	Description	Price
160438	PR6041/805	9405 36041802	Bottom plate, tank leg connection	\$380.28

Top Cable Outlet Options

Total Capacity	Load Cell Capacity	RLWS Part #	Minebea Part #	Price
3-Module Kit				
660 lb	300 kg	220 lb	100 kg	158843 CTG-332B-U \$8,816.60
1,300 lb	600 kg	440 lb	200 kg	158845 CTG-632B-U \$8,816.60
1,900 lb	900 kg	660 lb	300 kg	158847 CTG-932B-U \$8,816.60
3,300 lb	1,500 kg	1,100 lb	500 kg	158849 CTG-1532B-U \$8,816.60
6,600 lb	3,000 kg	2,200 lb	1,000 kg	158851 CTG-3032B-U \$8,816.60
13,200 lb	6,000 kg	4,400 lb	2,000 kg	158853 CTG-6032B-U \$8,816.60
4-Module Kit				
880 lb	400 kg	220 lb	100 kg	158844 CTG-442B-U \$11,556.43
1,700 lb	800 kg	440 lb	200 kg	158846 CTG-842B-U \$11,556.43
2,500 lb	1,200 kg	660 lb	300 kg	158848 CTG-1242B-U \$11,556.43
4,400 lb	2,000 kg	1,100 lb	500 kg	158850 CTG-2042B-U \$11,556.43
8,800 lb	4,000 kg	2,200 lb	1,000 kg	158852 CTG-4042B-U \$11,556.43
17,600 lb	8,000 kg	4,400 lb	2,000 kg	158854 CTG-8042B-U \$11,556.43

Complete Kit Includes:
Contega load cell, junction box, load cell extension cable

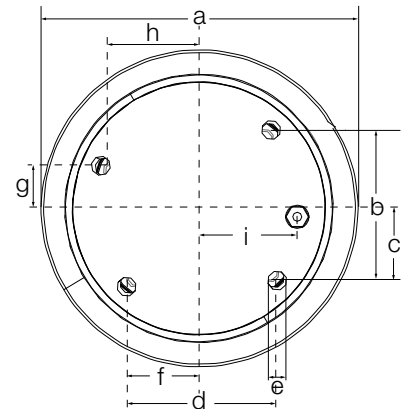

Dimensions

Rated Capacity	A	B	C	D	E	F	G	H	I
in/mm									
Top cable	8.3 in (210 mm)	3.7 in (94 mm)	1.9 in (47 mm)	3.7 in (94 mm)	0.5 in (12 mm)	1.9 in (47 mm)	1.1 in (29 mm)	2.4 in (60 mm)	2.2 in (55 mm)