

Specifications

Conveyor Widths:

18 in to 72 in

Capacity:

Up to 10,000 tons per hour

Belt Speed:

Up to 1,200 feet per minute

Accuracy Guidelines:

Single-two idler system: 0.5%-1% total error

Three-four idler system: <0.5% total error

System Accuracy:

Guidelines assume clean belt with automatic tensioning system. Accuracy guidelines are typical. System accuracy may vary depending on environmental influences.



Note: Idler not included. Customer is responsible for mounting idler to weigh frame.

Standard Features

- Experience durability and accuracy with Rice Lake's rugged BCI belt scale weigh frame. Built to last, the BCI is one of the most accurate belt scales in its class. Ideal for mining, quarries, bulk material blending, process control operations and load-out applications, the BCI easily handles capacities up to 10,000 tons per hour with unsurpassed accuracy.

Applications

- Mining, quarries, bulk material blending, process control, utilities, truck/barge/rail loading and retrofit

Part Number/Price

Part #	Description	Est. Belt Width	Capacity	Price
Mild Steel Weigh Frames				
94968	24 in weigh frame	18 in	500 lb	\$2,177.00
95208	30 in weigh frame	24 in	500 lb	\$2,177.00
95209	36 in weigh frame	30 in	500 lb	\$2,177.00
95210	42 in weigh frame	36 in	500 lb	\$2,177.00
95211	48 in weigh frame	42 in	500 lb	\$2,177.00
95212	54 in weigh frame	48 in	500 lb	\$2,177.00
96717	60 in weigh frame	54 in	1,000 lb	\$2,177.00
96718	66 in weigh frame	60 in	1,000 lb	\$2,177.00
96719	72 in weigh frame	66 in	1,000 lb	\$2,177.00
Consult	Light-capacity weigh frames			\$2,943.00
Stainless Steel Weigh Frames				
110839	24 in weigh frame	18 in	500 lb	\$3,156.00
105246	30 in weigh frame	24 in	500 lb	\$3,156.00
110841	36 in weigh frame	30 in	500 lb	\$3,156.00
110842	42 in weigh frame	36 in	500 lb	\$3,156.00
110843	48 in weigh frame	42 in	500 lb	\$3,156.00
110844	54 in weigh frame	48 in	500 lb	\$3,156.00
110845	60 in weigh frame	54 in	500 lb	\$3,156.00
110846	66 in weigh frame	60 in	500 lb	\$3,156.00
110847	72 in weigh frame	66 in	500 lb	\$3,156.00
Consult	Light-capacity weigh frames			\$4,248.00
Weigh Frame Accessories				
97413	Shim, plastic 1/16 in thick			\$0.35
97414	Shim, plastic 1/8 in thick			\$0.40
97415	Shim, plastic 1/4 in thick			\$0.60
97416	Kit, shim 50 each 1/16 in, 1/8 in and 1/4 in thick			\$55.00

Please complete the Belt Scale Application on page 173 to obtain a quote

BCi

In-Motion Belt Scale System

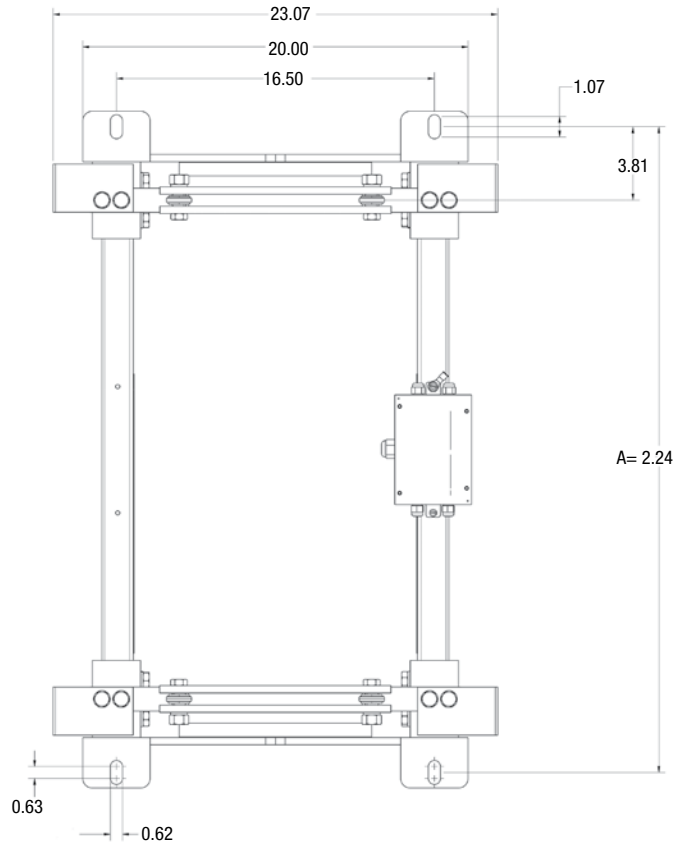
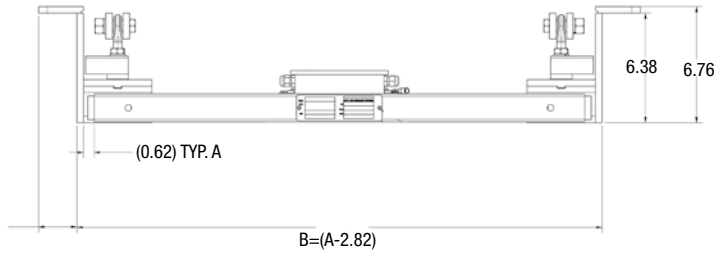

Note: Cables on drawings removed for clarity. Idler mounting hardware is not included in weigh frame, see idler mounting bolts above.