

Kiosk Safety Swing-away Arm

Self Centering Kiosk Mount



Standard Features

- Protects all kiosks from truck mirrors, fenders and cabs
- Swings away freely and returns to center position
- Universal mount accommodates a wide variety of kiosks
- Includes mounting pole and base stand
- Adjustable vertical and horizontal mounting

Part Number/Price

| Part # | Description | Price |
|--------|--|------------|
| 109164 | Complete kit for pit type scale (10 ft pole, red paint) | \$1,330.00 |
| 109163 | Complete kit for aboveground scale (12 ft pole, red paint) | \$1,360.00 |
| 105939 | Weldment, swing arm, kiosk (red) | \$715.00 |
| 105941 | Pole weldment, 10 ft supported/free standing, 4.5 in o.d. (red paint) | \$575.00 |
| 105940 | Pole weldment, 12 ft supported/free standing, 4.5 in o.d. (red paint) | \$640.00 |
| 110606 | Weldment, swing arm 24 x 24 x 16 in side discharge printer kiosk (red paint) | \$695.00 |
| 155435 | Weldment, swing arm 30 x 24 x 16 in side discharge printer kiosk (red paint) | \$945.00 |
| 178074 | Complete kit for pit type scale (10 ft pole, yellow paint) | \$1,330.00 |
| 178073 | Complete kit for aboveground scale (12 ft pole, yellow paint) | \$1,360.00 |
| 178077 | Pole weldment, 10 ft supported free standing 4.5 in outer dimension (yellow) | \$575.00 |
| 178076 | Pole weldment, 12 ft supported free standing 4.5 in outer dimension (yellow) | \$640.00 |
| 178075 | Weldment, swing arm kiosk (yellow) | \$715.00 |

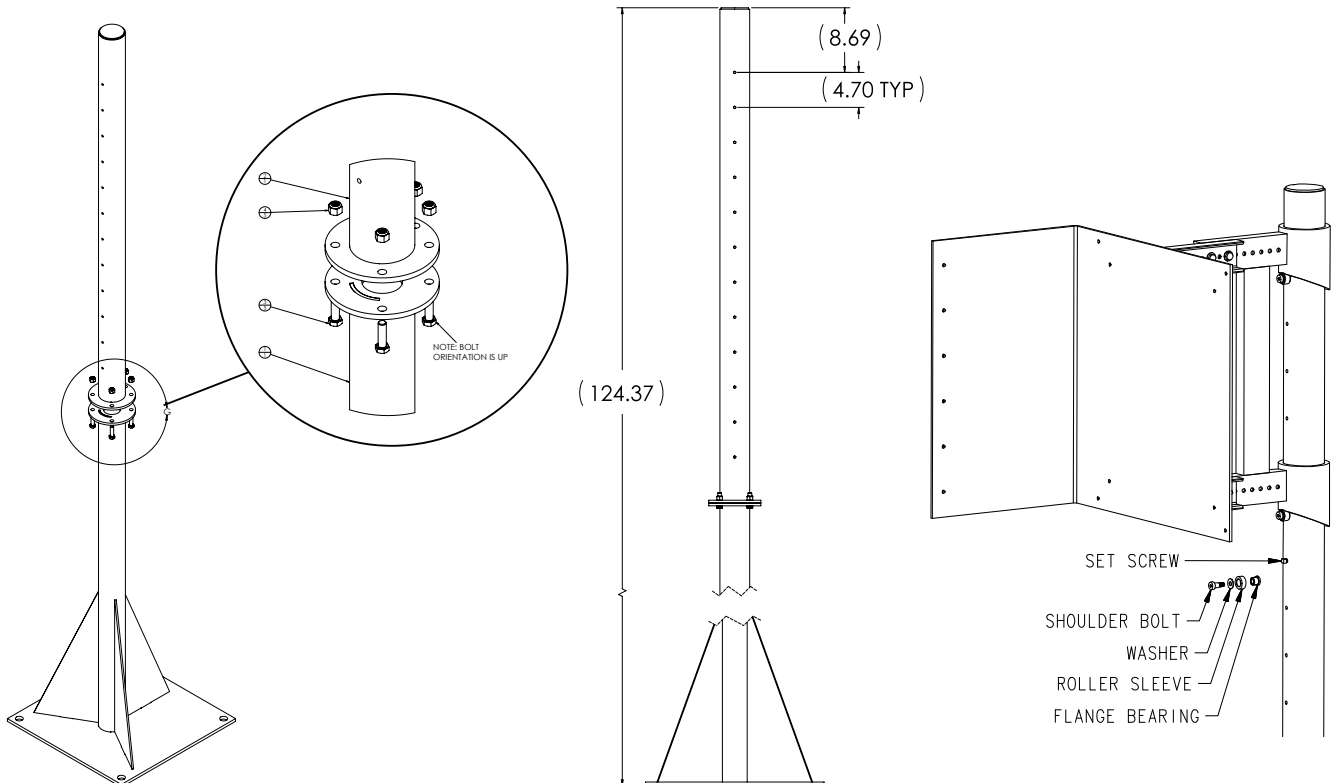

Kiosk Safety Swing-away Arm

Self Centering Kiosk Mount

