



## DD-500 DUAL DUCT AIR TERMINAL UNIT

### SPECIFIABLE FEATURES

- 22 ga. galvanized steel casing, mechanically sealed, low leakage construction.
- Damper construction of double layer 18 gauge equivalent with integral blade seal.
- Butt welded round primary inlet duct to minimize leakage.
- Metal inlet flow sensor with extra balancing taps.

INDEX OF SECTIONS	PAGE
Dimensional Data	4
AHRI Certified Rating Points	5
Sound Performance Data	6
Casing Leakage / Damper Leakage	8
Certifications and Standards	8
Recommended Min/Max Airflow Ranges	9
Control Sequence Offerings	10



## DD-500 DUAL DUCT AIR TERMINAL UNIT

The METALAIRE DD-500 air terminal units are designed to regulate the flow of conditioned air in a dual duct air distribution system. Both heated and cooled air are provided to the air terminal and mixed in a plenum provided by others to reach the desired discharge temperature.

### STANDARD FEATURES

- Available in multiple unit sizes to handle 30–5020 CFM.
- Unequal inlet sizes are available as an option.
- Variable or constant volume applications.
- 22 ga. galvanized steel casing, mechanically sealed, low leakage construction.
- Mechanically fastened damper assembly is double layer, 18 gauge equivalent, galvanized steel with integral blade seal. (<1% at 3" static pressure).
- Optional factory calibrated controls per each job requirement.
- Multi-quadrant, averaging flow sensor for highly accurate (+/-5%) flow readings with varying inlet duct configurations after certified balancer has balanced terminal.
- Externally accessible, steel balancing taps.
- External control cabinets for hot and cold deck with offset mounting plate.
- 3-beaded inlet connection tube for added rigidity and secure flex duct connections.
- 1/2" thick, dual density (1.5lb / ft<sup>3</sup> min.) fiberglass insulation with edges coated. Meets NFPA 90A and UL 181.
- Rectangular discharge with slip and drive cleat duct connection.
- Independently tested and certified laboratory performance data.
- Full range of liners / insulation available.

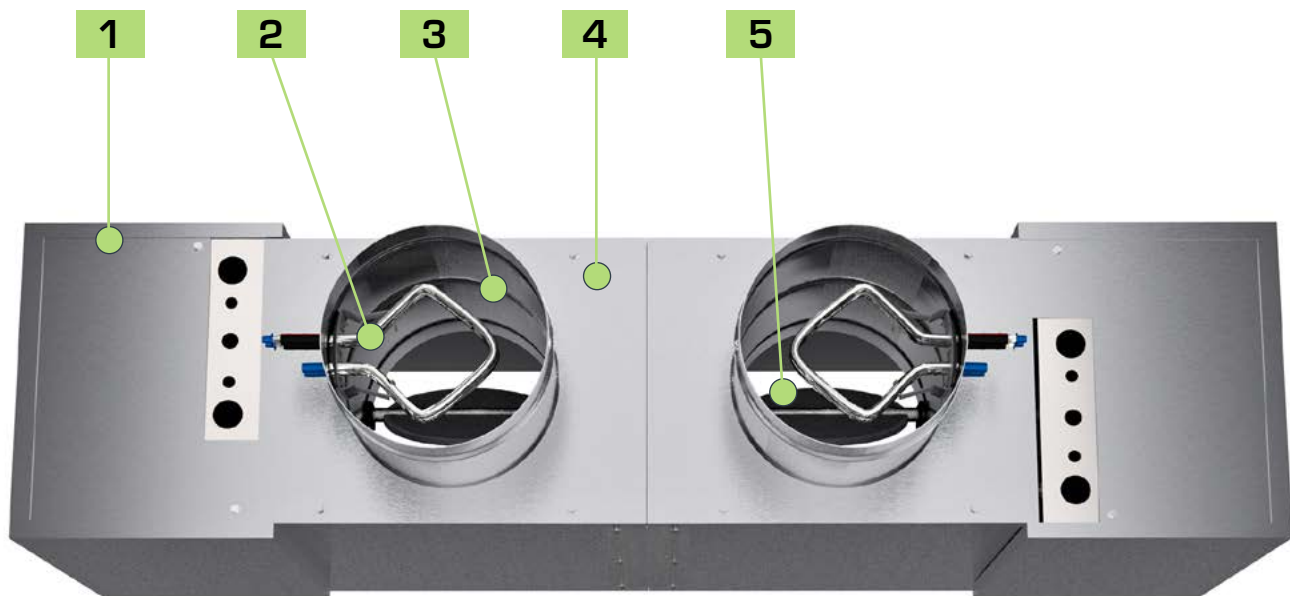

## DD-500 DUAL DUCT AIR TERMINAL UNIT

### FEATURES AND BENEFITS

- 1** NEMA TYPE 1 rated control enclosures for both hot and cold decks with stand-off to prevent penetration of casing are standard on all terminal units.
- 2** All metal constructed inlet flow sensor with extra balancing taps.
- 3** Continuous welded primary inlet duct to minimize leakage with three stiffening beads for added rigidity.
- 4** Galvanized steel casing, mechanically sealed for low leakage construction.
- 5** Damper rotates in a self-lubricating, long life, low friction thermoplastic bearing.

## DD-500 DUAL DUCT AIR TERMINAL UNIT

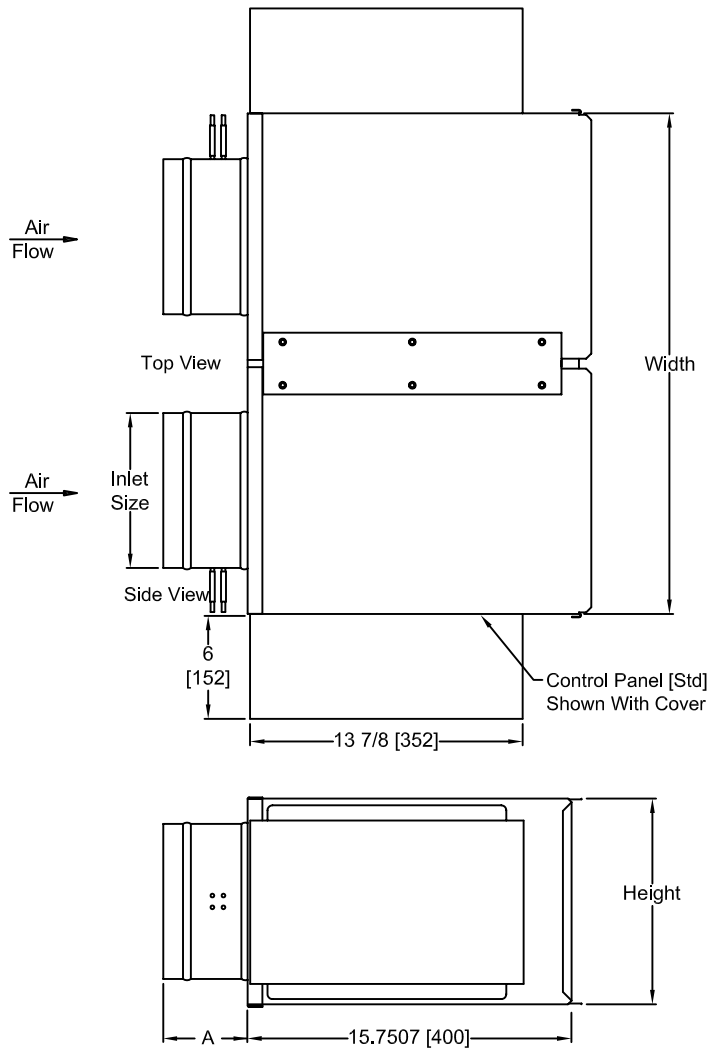

The control panels will overhang the top and bottom of Models DD504–DD506 1 13/16" (46 mm) or 13/16" (20 mm) on DD508. Control Panel Mounting Surface width by height is 13 7/8" x 9 3/4".

Unit Size	Inlet Size		A		Width		Height		Unit wt.	
	in.	mm.	in.	mm.	in.	mm.	in.	mm.	lb.	kg.
4	3 7/8	99	10	254	24 1/4	305	8	203	24	11
5	4 7/8	124	5	127	24 1/4	305	8	203	24	11
6	5 7/8	149	5	127	24 1/4	305	8	203	24	11
7	7 7/8	200	5	127	24 1/4	305	10	254	30	14
8	7 7/8	200	5	127	24 1/4	305	10	254	30	14
9	9 7/8	251	5	127	28 1/4	356	12 1/2	318	36	16
10	9 7/8	251	5	127	28 1/4	356	12 1/2	318	36	16
12	11 7/8	302	5	127	32 1/4	406	15	381	44	20
14	13 7/8	353	5	127	40 1/4	508	17 1/2	445	48	22
16	15 7/8	403	5	127	48 1/4	610	18	457	58	26

## DD-500 AHRI CERTIFIED RATING POINTS



### RADIATED SOUND

Power Levels @ 1.5" w.g. ΔPs

Unit Size	CFM	Min Ps	Octave Band						
			2	3	4	5	6	7	
4	150	0.03	48	40	32	28	23	20	
5	250	0.06	54	46	42	34	31	30	
6	400	0.08	56	52	46	40	38	36	
7	550	0.08	59	53	46	41	34	31	
8	700	0.10	62	56	48	44	36	32	
9	900	0.02	56	57	51	43	37	31	
10	1100	0.02	58	58	52	44	38	32	
12	1600	0.01	64	58	54	46	42	36	
14	2100	0.01	62	52	50	42	38	38	
16	2800	0.03	64	63	58	52	48	46	

### DISCHARGE SOUND

Power Levels @ 1.5" w.g. ΔPs

Unit Size	CFM	Min Ps	Octave Band						
			2	3	4	5	6	7	
4	150	0.03	61	57	54	49	43	37	
5	250	0.06	63	59	56	50	46	41	
6	400	0.08	62	58	54	46	42	44	
7	550	0.08	69	66	60	57	52	47	
8	700	0.10	70	68	62	59	56	52	
9	900	0.02	69	66	62	58	54	50	
10	1100	0.02	71	68	63	59	55	52	
12	1600	0.01	72	72	62	63	58	54	
14	2100	0.01	68	64	62	58	56	54	
16	2800	0.03	77	77	73	70	65	60	

### PERFORMANCE NOTES

- 1) Radiated sound is the noise transmitted through the unit casing
- 2) Discharge sound is noise emitted from unit discharge into downstream ductwork
- 3) Sound power levels expressed in decibels, (dB) re 10<sup>-12</sup> Watts
- 4) Min ΔPs is the min. operating pressure requirement of the unit with the damper full open and is the static pressure drop from the unit inlet to the unit discharge
- 5) Performance data based on laboratory tests conducted in accordance with ASHRAE 130-2016 and AHRI 880-2017
- 6) Discharge sound power levels include duct end reflection corrections per AHRI Standard 880-2017
- 7) Sound performance based on units lined with standard dual density fiberglass insulation

DUAL DUCT

DD-500 DUAL DUCT





## DD-500 STANDARD CONSTRUCTION CASING AND DAMPER LEAKAGE

Standard Construction				
Inlet Diameter	Static Pressure " w.g.	Maximum Airflow	Max Casing Leakage	Max Damper Leakage
4	3	300	5	5
5	3	375	5	5
6	3	540	5	5
7	3	760	7	7
8	3	990	9	9
9	3	1250	12	12
10	3	1640	16	16
12	3	2350	22	22
14	3	3250	32	32
16	3	4100	41	41
20	3	6430	64	64
24	3	7270	72	72

### PERFORMANCE NOTES

- 1) Leakage testing conducted in accordance with ASHRAE 130-2016
- 2) Per ASHRAE Standard 130-2016 "terminal casing leakage: the amount of the air in ft<sup>3</sup>/min (L/s) leaking from the terminal unit at a given inlet pressure with the outlet(s) and inlet(s) blocked and with the damper/valve fully opened"
- 3) Per ASHRAE Standard 130-2016 "terminal damper leakage: the amount of air in ft<sup>3</sup>/min (L/s) leaking through a fully closed damper/valve of a supply/exhaust terminal unit at a given inlet pressure"opened"
- 4) Casing and Damper leakage shall not exceed 1% of the maximum rated airflow at 3" w.g.
- 5) 4" and 5" inlets are built with 6" casings

### CERTIFICATIONS AND STANDARDS

- Units tested per ASHRAE Standard 130-2016.
- All model sizes certified in accordance with AHRI 880-2017 certification program.
- ETL listed to meet requirements of UL 1995 and CSA 236.
- Dual-density fiberglass insulation meets UL 181 and NFPA 90A/90B.
- Insulation meets ASHRAE 62.1 requirements for resistance to mold growth and erosion.
- Hot water coils are manufactured in accordance to AHRI Standard 410.



## DD-500 RECOMMENDED MIN/MAX AIRFLOW RANGES

DD-500 Recommended Minimum and Maximum Airflow Ranges						
Unit Size	Pneumatic / Analog		Digital Controls - DDC			
			Transducer Min $\Delta P$ / Min CFM		Transducer Max $\Delta P$ / Max CFM	
	Min CFM	Max CFM	0.01	0.03	1	1.5
4	50	300	30	50	300	370
5	65	375	40	65	375	460
6	95	540	55	95	540	660
7	130	760	75	130	760	930
8	170	990	100	170	990	1210
9	220	1250	125	220	1250	1530
10	285	1640	165	285	1640	2010
12	410	2350	235	410	2350	2880
14	565	3250	325	565	3250	3980
16	710	4100	410	710	4100	5020

### PERFORMANCE NOTES

- 1) Actual minimum and maximum airflow ranges depend on the transducer differential pressure range and accuracy.
- 2) Contact the manufacturer of installed DDC equipment for transducer minimum and maximum differential pressure,  $\Delta P$ , limits.
- 3) Minimum CFM for Pneumatic and Analog controls are based on a sensor differential pressure of 0.03 in. w.g.
- 4) Maximum CFM for Pneumatic and Analog controls are based on a sensor differential pressure of 1.00 in. w.g.
- 5)  $CFM = (\sqrt{\Delta P}) * K$  Factor
- 6) K Factor is the airflow at 1"  $\Delta P$
- 7) Recommendations are for pressure independent units.
- 8) Pressure dependent units minimum CFM is always zero and there is no maximum.

## DD-500 CONTROL SEQUENCE OFFERINGS



### PPD-PNEUMATIC PRESSURE DEPENDENT

- 210 Direct Acting / Normally Closed (DA / NC)
- 212 Reverse Acting / Normally Open (RA / NO)



### PPI-PNEUMATIC PRESSURE INDEPENDENT

- 238 NO Cold Duct – NC Hot Duct – DA Thermostat
- 239 NO Cold Duct – NC Hot Duct – RA Thermostat
- 240 NC Cold Duct – NO Hot Duct – DA Thermostat
- 241 NC Cold Duct – NO Hot Duct – RA Thermostat

*NO = Normally Open, NC = Normally Closed  
DA = Direct Acting, RA = Reverse Acting*



### EPD-ELECTRIC PRESSURE DEPENDENT

- 257 Actuator Only
- 258 Sensors in Hot / Cold Inlets and Actuator



### API-ANALOG PRESSURE INDEPENDENT

- 263 Hot and Cold Actuators Operate in Sequence



### DDC-DIRECT DIGITAL CONTROL

#### BACnet

- Consult Factory for Direct Digital Controls (DDC)

*Refer to ACC 24 for complete description.*