



Zephyr Revolution

Exhaust Fan Catalog

BULLETIN ZR17

TABLE OF CONTENTS

Introduction	3
Features & Benefits	4
Certifications & Listings	4
Options & Accessories	6
Installation	13
Dimensional & Performance Data	14
Engineering Specifications	19

INTRODUCTION

Zephyr Revolution ZRB Model

With the highest CFM/W for its size, Zephyr Revolution precision ceiling and inline exhaust fans are the most energy efficient as well as some of the quietest commercial and residential airflow management systems on the market. Featuring direct-drive totally enclosed EC motors, precision-tuned centrifugal wheels and a CFD optimized inlet, Zephyr Revolution exhaust fans deliver precision, performance, and versatility. Figure 1 illustrates some of the key features.

All Zephyr Revolution model configurations are easy to install and come with AMCA and UL certifications. Available installation accessories include motion sensors, a humidity sensor, ceiling radiation damper, as well as a number of grille options. Figure 2 shows the ceiling and inline configuration options.

The units utilize quick access wiring, making them easy to install and are offered with variable speed motor control, allowing for easy balancing. All models are AMCA Air and Sound rated, UL705 and UL507 listed.

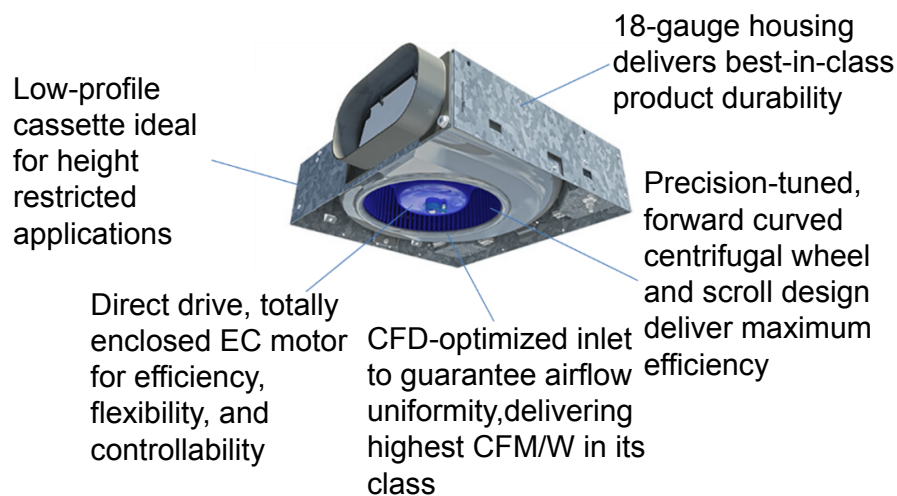

Figure 1 Zephyr Revolution

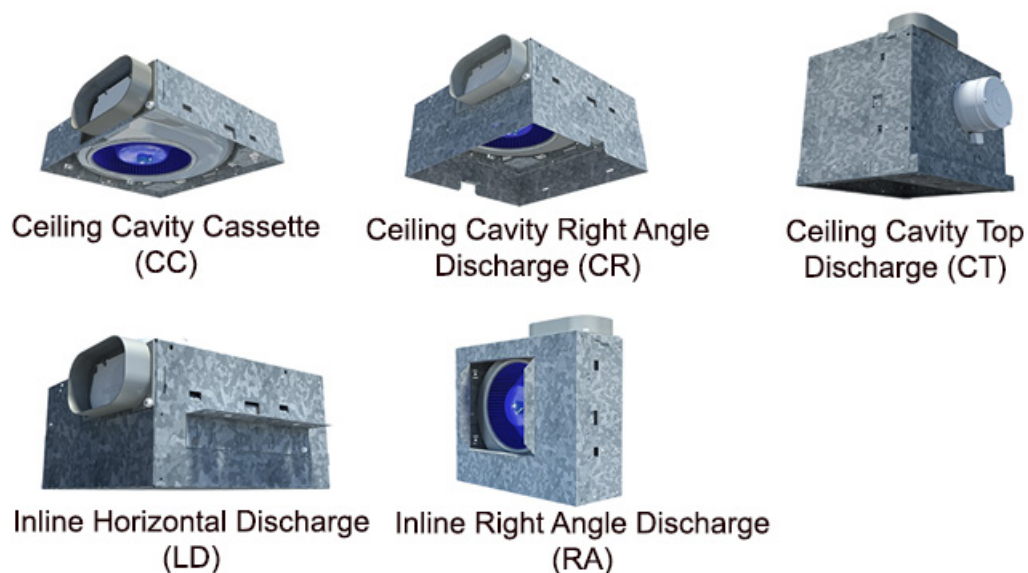

Figure 2 Zephyr Revolution Configurations

FEATURES & BENEFITS

Zephyr Revolution Ceiling Fans

Zephyr Revolution ceiling fans are available in five configurations, consisting of three ceiling configurations: ceiling cavity cassette, ceiling cavity right-angle discharge, ceiling cavity top discharge, and two inline configurations: inline horizontal discharge and inline right-angle discharge. The low-profile ceiling cavity cassette is ideal for height-restricted installations. See Figure 3.

Each ceiling unit comes with a white ABS grille and utilizes a quiet centrifugal blower wheel. All units have a direct-drive, totally enclosed EC motor, serviceable from the room side. For durability, the housing is made from 18ga galvanized steel. The exhaust outlet is a 6" ABS oval duct connector that has a damper to eliminate backdrafts and produces no metallic clatter. All ceiling units are UL705 and UL507 listed for use over bathtubs and showers when connected to a GFCI protected branch circuit. Zephyr Revolution fans are AMCA certified for Sound and Air performance.

Model: ZRB

- Static pressure performance beyond 1.0" w.g.
- Flow capacity from 100 to 500 CFM

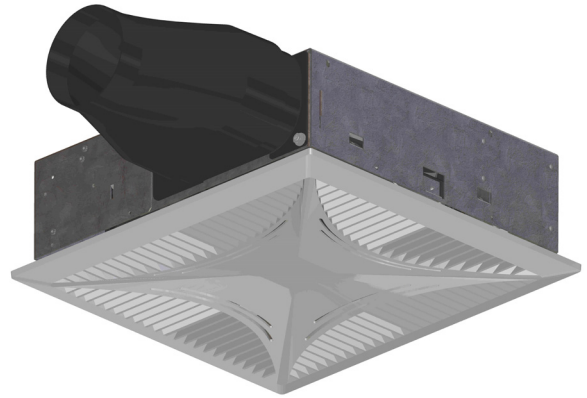

Figure 3 Ceiling Cavity Cassette

Zephyr Revolution Fans with Light

Two architectural designed styles are available, a 12 Watt, 1,000 lumens grille and a 25 Watt, 2,100 lumens panel grille. The units are supplied with a totally enclosed motor that utilizes sealed bearings. They utilize quiet centrifugal blower wheels with plug in receptacles for the fan and light. For durability, the housing is made from 18ga galvanized steel. The exhaust outlet is a 6" ABS oval duct connector that has a damper to eliminate backdrafts and produces no metallic clatter. See Figure 4. All ceiling units are UL705 and UL507 listed for use over bathtubs and showers when connected to a GFCI protected branch circuit. Zephyr Revolution fans are AMCA certified for Sound and Air performance.

CR, CT – Lighted ArtDeco Grille

CC, CR, CT – Lighted Panel

Model: ZRB

- Static pressure performance beyond 1.0" w.g.
- Flow capacity from 100 to 500 CFM

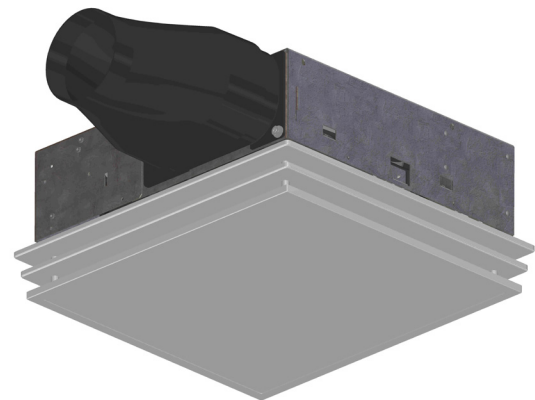

Figure 4 Lighted Panel Grille

CERTIFICATIONS & LISTINGS



AMCA Certification

PennBarry certifies that the Zephyr Revolution models are licensed to bear the AMCA Seal. The ratings shown are based on tests and procedures performed in accordance with AMCA Publication 211 and AMCA Publication 311 and comply with the requirements of the AMCA Certified Ratings Program.



UL and cUL Certification

Zephyr fans carry the UL label, UL705, (ZACT/ZACT7), file #E28413 and UL507 file #E39313. Zephyr fan radiation dampers carry the UL label UL555C, (CABS), file #R8039.

FEATURES & BENEFITS

Low Sound

For sound critical applications, the Zephyr Revolution offers select models delivering down to 0.3 sones. All Zephyr Revolution sleeves are acoustically insulated, and feature custom designed scroll and motor pairings designed to minimize sound.

High Static Pressures

When higher static pressures are encountered, the Zephyr Revolution fans excel. Built in EC motor logic allows the fans to better sustain airflow as static pressure increases. This makes them well suited for inline applications.

Housings

Housings are fabricated using 18ga galvanized steel for durability, increasing the protection against corrosion and greatly expanding the life of the products. Acoustical installation in the sleeves is used to minimize sound.

Speed Selection

All Zephyr Revolution models are provided with an on-board speed control which simplifies system balancing and can be used to accommodate system deficiencies upon installation. If an optional remote speed control is used, the on-board speed control will need to be deactivated. System deficiencies can be accommodated in the field quickly and without the added cost of replacing a fan.

Motors

All units have permanently lubricated totally enclosed direct drive EC motors manufactured to PennBarry's exacting specifications. Two motors are available in 26W and 106W. Motors feature built-in overload protection compliant with agency requirements.

Grilles

Engineered to lessen restrictions and increase efficiencies, six aesthetically pleasing grille designs are available. Three styles are constructed using ultra-lightweight polymer, compliant with agency requirements. Extensive ABS flow analysis was conducted to guarantee the highest quality of surface finish and no witness lines. Optional grilles include a perforated all-aluminum grille with an appliance white finish and two lighted grilles, employing state-of-the art LED technology. For ease of removal and cleaning, the grilles are held in place with spring clips.

Wheels

Precision-tuned, forward-curved centrifugal wheels are dynamically balanced and performance matched with the motor to deliver maximum efficiency. Comprised of ultra-lightweight polymer, the wheels yield a lighter, high-performance product. The scroll inlet and outlet are optimized via CFD to achieve the highest energy efficiency and the lowest sound signature possible while guaranteeing airflow uniformity.

Quick Access Wiring

Zephyr Revolution's internal wiring ensures ease of service and assures a single point connection to facilitate the installation process.

Ease of Serviceability

All Zephyr Revolution models are easy to install. The ceiling units are fully serviceable from the interior space.

OPTIONS & ACCESSORIES

Grilles

Several aesthetically pleasing grille designs are available. All Zephyr Revolution grilles come in “appliance white” color. See Figure 5 below.



Full Diagonal



Patchwork Diagonal

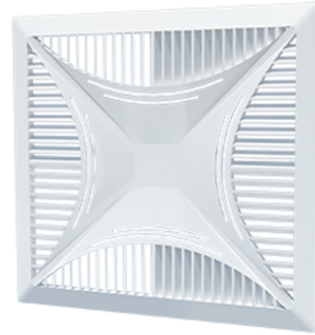

ArtDeco

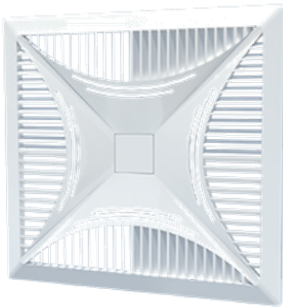

Lighted ArtDeco LED 12W
 • 12W
 • 1000 lumens
 • 3000K color temperature



Lighted Panel LED 25W
 • 25W
 • 2100 lumens
 • 4000K color temperature



Perforated Aluminum

Figure 5 Grille Options

Dimensional Data for Accessory Grilles

Model	Grille	
	L	W
ZRB -- All Configurations	15.5"	14.25"

OPTIONS & ACCESSORIES

Figure 6 Accessory Matrix

Figure 6 provides a list of the standard and optional accessories for each of the configurations.

Model	Ceiling Cavity Cassette (CC)	Ceiling Cavity Right Angle Discharge (CR)	Ceiling Cavity Top Discharge (CT)	Inline Horizontal Discharge (LD)	Inline Right Angle Discharge (RA)
Grille – Full diagonal - plastic	S	S	S	-	-
Grille – Patchwork diagonal - plastic	O	O	O	-	-
Grille – ArtDeco - plastic	O	O	O	-	-
Grille – Perforated aluminum	-	O	O	-	-
Grille – Lighted ArtDeco LED 12W	-	O	O	-	-
Grille – Lighted panel LED 25W	O	O	O	-	-
Housing brackets	-	O	O	S	-
Mounting channel assembly	S	S	S	O	O
Vibration isolation hanger	-	O	O	O	-
Duct transition – 4”	O	O	O	O	O
Duct transition – 6”	S	S	S	S	S
Washable air filter	-	O	O	-	-
Ceiling radiation damper‡	O	O	O	-	-
Brick vent	O	O	O	O	O
Roof cap – flat	O	O	O	O	O
Roof cap – curb mount	O	O	O	O	O
Roof cap - slope	O	O	O	O	O
Wall cap	O	O	O	O	O
Humidity sensor – wall mount	O	O	O	O	O
Motion sensor – ceiling mount	O	O	O	O	O
Motion sensor – wall mount	O	O	O	O	O

S Standard

O Option

‡ Damper is field installed, shipped separate from fan; damper cannot be installed with lighted grille options

OPTIONS & ACCESSORIES

Motion Sensors

For applications where automated operation of the fan is required, a motion detector can be used to turn the fan on or off. The sensor features full scanning capabilities and is available in ceiling and wall mount configurations. The sensor also offers adjustable shutoff feature with delays of up to 15 minutes. See Figure 7.

Humidity Sensors

For automatic detection of excess humidity in a room, a wall mounted humidity sensor can be installed to activate the fan. The sensor is a microprocessor controlled with state-of-the-art digital sensing technology to continuously monitor and manage humidity levels in rooms prone to condensation and mildew. Contemporary in design, the sensor features user-friendly controls to adjust sensitivity, humidity level and time-out settings. The sensor time settings can be custom set to 10, 20, 30 or 45 minute intervals. The sensor helps reduce energy usage by automatically operating the fan only when needed to control excess humidity. See Figure 8.

Step Down Transformer

To meet certain job requirements or retrofit applications, a 277V to 120V stepdown transformer is available to enable the use of the 26W motor on a 277V circuit. The transformer is shipped loose for field installation.



Figure 7 Ceiling and wall mount motion detectors



Figure 8 Humidity Sensor

OPTIONS & ACCESSORIES

Housing Brackets

Housing brackets are recommended for use with the vibration isolation hanger kit. See Figure 9.

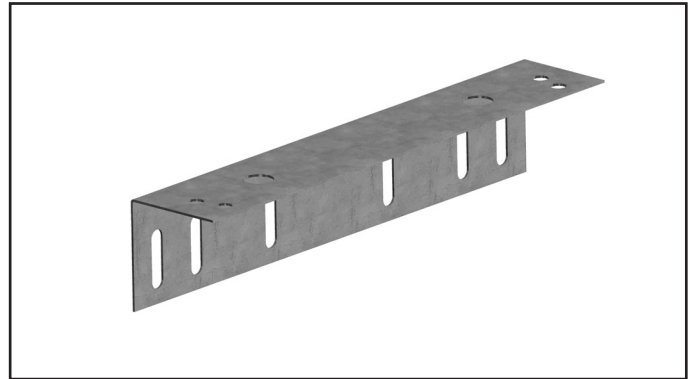

Figure 9 Housing Brackets

Mounting Channel Assembly

The Mounting Channel Assembly comes standard with the three ceiling configurations. Designed for ease of installation, the mounting channels are adjustable from 18 inches to 27.5 inches. See Figure 10.

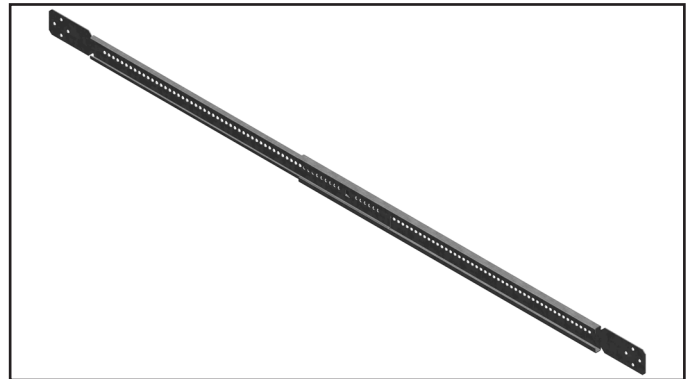

Figure 10 Mounting Channel Assembly

Vibration Isolation Hanger Kit

Vibration Isolation Hangers feature rubber-in-shear type and are available for use on select units. See Figure 11.

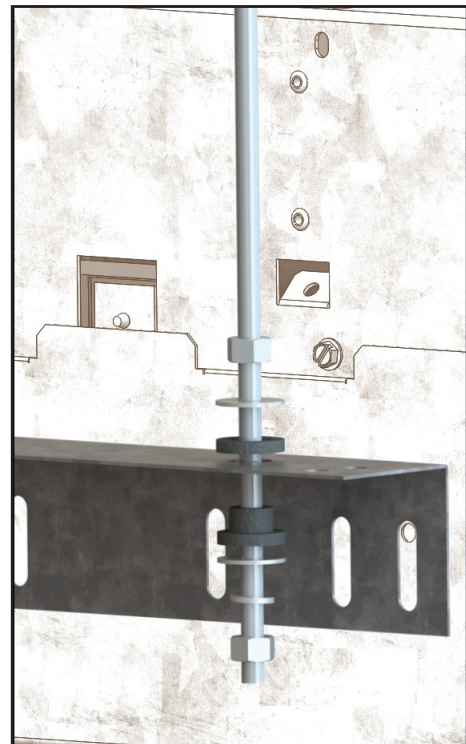
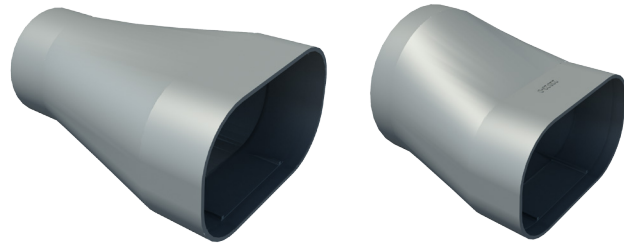

Figure 11 Vibration Isolation Hanger

OPTIONS & ACCESSORIES

Duct Transitions

Designed to make the installation of flex duct quick and easy, duct transitions are available in two sizes to accommodate the most common flex duct sizes. See Figure 12.



4" Duct Transition

6" Duct Transition

Figure 12 4" and 6" Duct Transitions

Duct Transition	Part No.	Outlet	Duct
ZRB	22023-0	7.05" x 4.35"	6"
ZRB	22027-0	7.05" x 4.35"	4"

Washable Air Filter

Constructed with aluminum for strength and durability, the washable air filter delivers high overall performance at velocities up to 650 fpm. The air filter meets UL Class 2 filter requirements. The unique baffle design provides high dust holding capacity for longer service life and increased overall performance. See Figure 13.

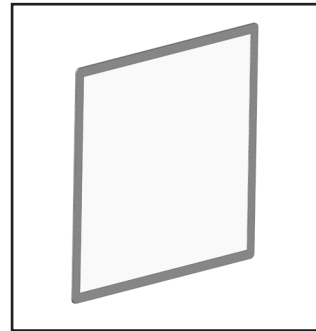

Figure 13 Washable Air Filter

Ceiling Radiation Damper

For areas where local codes require fire dampers for compliance with National Fire Protection Standard 90A, PennBarry offers a UL approved damper, UL555C, (CABS), file #R8039. The dampers are rated for 3 hours and are activated at 165°F. Compact in design, the dampers add only 6.25" or 7.25" in height when mounted between the fan and the grille. Static pressure created by the damper is negligible.

Brick Vents

Sized to replace the standard size brick or concrete block. Made of extruded aluminum with insect screens, storm proof features and a protective finish, it is a superior vent and ideal for installation in masonry walls. See Figure 14.

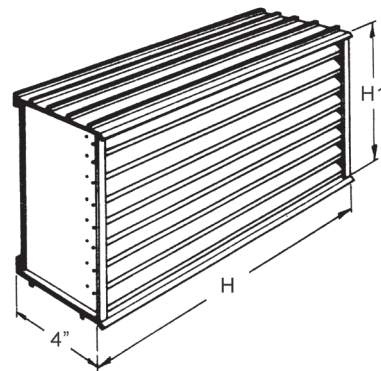

Figure 14 BRICK VENT B68

Brick Vent Model

Brick Vent Model	Zephyr Model	H	H1	S
B68	ZRB	16 1/2"	4 3/4"	4"

OPTIONS & ACCESSORIES

Sloped Roof Caps

Caps are available for sloped roof applications. Minimum height model SL20 is durable and has a backdraft damper. See Figure 15.



Figure 15 Roof Caps

Roof Caps

These spun aluminum, rustproof, seamless vents provide a discharge cap for flat roof mounting. Unobtrusive and furnished with integral bird screen, they are designed for simple, safe flashing directly to the roof. Mounting flanges are also available turned down as cap flashing when installation on roof curbs is desired. See the PennBarry Weathercap Bulletin for more information. See Figure 16.

Wall Caps

Inconspicuous but efficient wall outlets for the Zephyr Revolution fans are provided through the use of the Wall Cap. Architectural values are not diminished by this tastefully designed accessory. When properly installed, it is both watertight and effective. See Figure 17. Figure 18 provides a list of the roof and wall cap models.

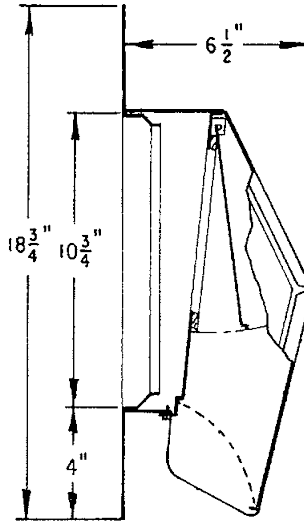

SL20 Roof Cap - Slope

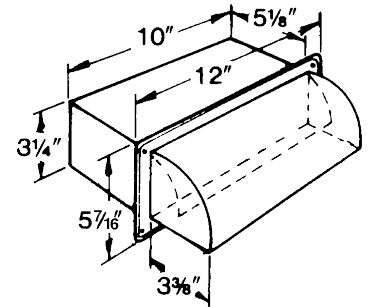

WC10 Wall Cap

Figure 17 Roof and Wall Caps

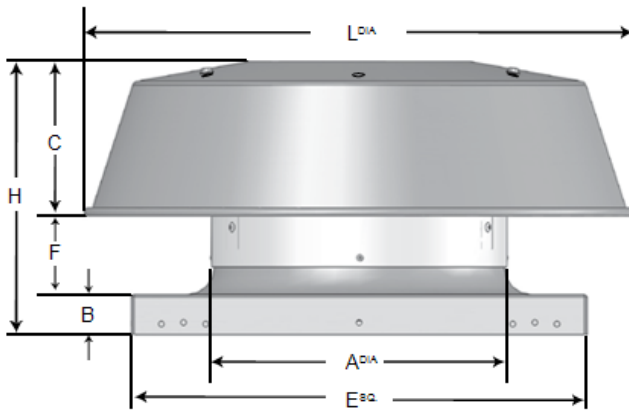

WCC ROOF CAP (CURB MOUNTED)

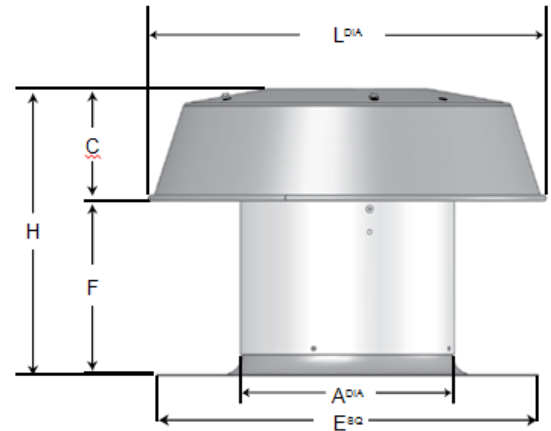

WCF ROOF CAP (SELF FLASHING)

Figure 16 WCC and WCF Roof Caps

Item	Model	A (Throat) Dia	B	C	E SQ	F	H	L-Dia	Damper SQ
ZRB Roof Cap - Flat	WCF06	7"	N/A	3 1/2"	16 7/8"	8"	11 1/2"	12"	NA
ZRB Roof Cap - Curb Mount	WCC06	7"	1	3 1/2"	15"	4"	8 1/2"	12"	8 3/4"
ZRB Roof Cap - Slope	SL20	-	-	-	-	-	-	-	-
ZRB Wall Cap	WC10	-	-	-	-	-	-	-	-

Figure 18 Roof and Wall Cap Models

©PENNBARRY 2017

Guide Lines for Selecting the Zephyr Revolution for Vents

When optional accessories are selected, it may be necessary to address the increase in system pressure. In this section, guidelines are provided to assist you in properly selecting the Zephyr Revolution model to properly account for the added pressure.

Static Pressure Calculators for Vents

Figure 19 provides a means to calculate the pressure drop in inches water gauge for the accessories on pg. 11-12, namely the Brick Vent B68, WCC Roof Cap, and WCF Roof Cap.

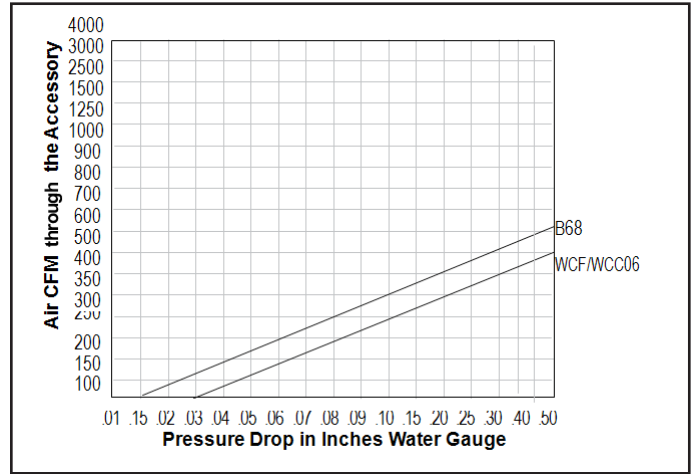

Figure 19 Static Pressure Drop Chart for Accessories

Static Pressure Calculator for 4” Ducts

Zephyr Revolution catalog performance table data are rated for 6” ducts. To select the proper Zephyr Revolution model for 4” duct applications, a system pressure correction factor, ΔP, must be added to the desired operating pressure. The pressure correction factor is calculated by :

Where Q is the desired flow in CFM

$$\Delta P = 8 \times 10^{-6} \times Q^2$$

Example: Given an application with a 4” duct system requiring an operating point of 200 cfm and 0.25 in-wg., the pressure correction factor is calculated as follows:

$$\Delta P = 8 \times 10^{-6} \times (200)^2 = 0.32 \text{ in-wg.}$$

Therefore, the pressure needed to select the correct Zephyr Revolution model is 0.25 in-wg. (desired operating pressure) + 0.32 in-wg.(the correction factor) = 0.57 in-wg.

Therefore in selecting the right Zephyr Revolution model, you would enter 200 CFM @ .57 in-wg.

This will assure that the selected model will perform in the 4” duct application at the desired operating point of 200 CFM and 0.25 in-wg.

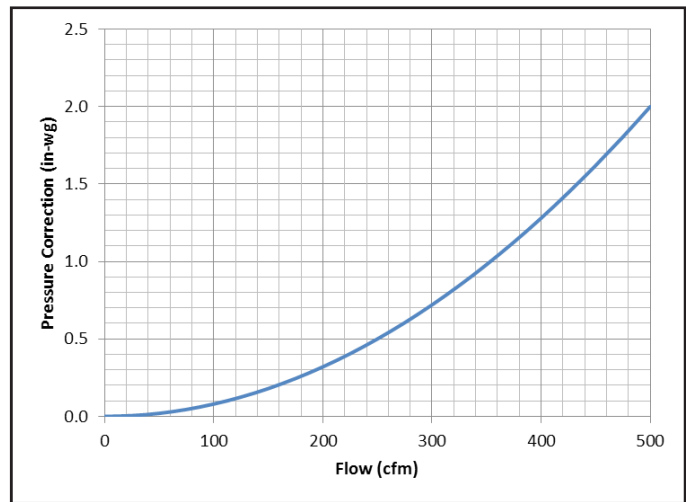

Figure 20 Static Pressure Adjustment for 4” Ducts

INSTALLATION

Typical configuration installations are shown in Figures 21-22.

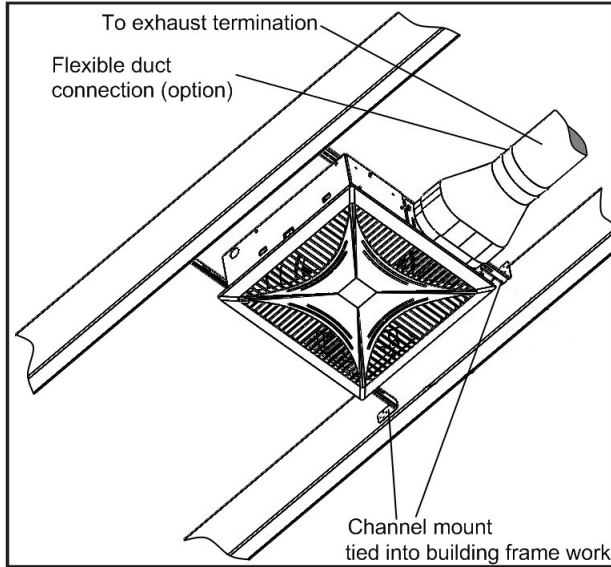

Figure 21 Ceiling Cavity Cassette Installation

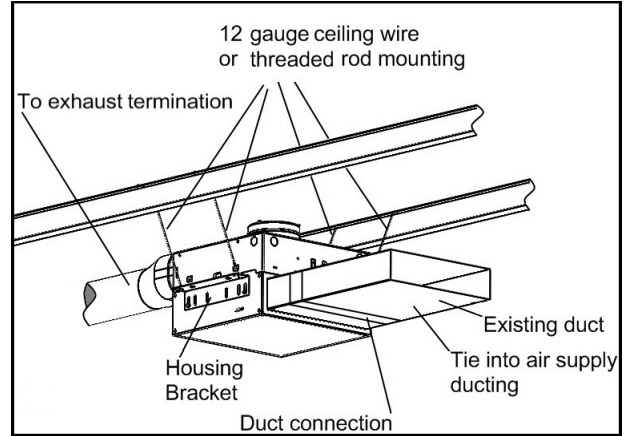
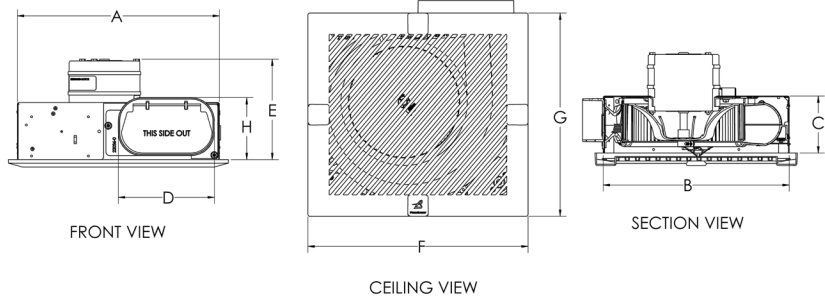

Figure 22 Hanging Inline Unit Installation

CEILING CAVITY CASSETTE | ZRB-CC

- AMCA Air & Sound certified
- Sound levels under one sone available on select models
- UL Listed for UL705 and UL507
- Direct drive, totally enclosed EC motor
- Variable speed control
- All motors with thermal overload protection
- Low profile units available
- Quick access wiring



Dimensional Data										
A	B	C	D	E		F	G	H	Est. Shipping Wt. (Lbs.)	
14.23	13.10	4.00	6.73	26 W (1/28 HP)	106 W (1/7 HP)	15.50	14.25	4.31	26 W (1/28 HP)	106 W (1/7 HP)
				4.00	7.04				22.0	29.0

Model	RPM	CFM/Watt @ .1SP	0.0 SP		.100 SP		.125 SP		.250 SP		.375 SP		.500 SP		.625 SP		.750 SP		.875 SP		1.00 SP		
			CFM	Sones	CFM	Sone	CFM	Sones	CFM	Sones	CFM	Sones	CFM	Sones	CFM	Sones	CFM	Sones	CFM	Sones	CFM	Sones	CFM
ZRB6-CC120	585	16.92	146	1.1	124	0.9	118	0.9	94	1.5	62	2.5											
ZRB6-CC140	670	15.08	159	1.5	141	1.2	136	1.1	116	1.5	85	2.5	59	3.5									
ZRB6-CC150	730	13.85	169	1.3	149	1.2	145	1.2	127	1.5	100	2.5	74	3.5									
ZRB6-CC180	805	12.00	198	2.5	181	2.0	176	2.0	159	2.5	136	2.5	107	3.5	83	4.5							
ZRB6-CC210	865	9.43	221	3.0	209	3.0	207	3.0	191	3.0	171	3.0	150	3.5	126	4.5	100	5.0	81	5.5			
ZRB6-CC240	965	9.58	255	3.5	245	3.5	242	3.5	227	3.5	206.5	3.5	186	3.5	150.5	3.5	115	3.5	91	3	67	5	
ZRB6-CC280	1000	8.24	284	4.5	278	4.5	275.5	4.5	263	4.5	245.5	4.5	228	4.5	205.5	4.5	183	4.5	163.5	4.5	144	4.5	
ZRB6-CC310	1055	7.34	323	5.5	313	5.5	310.1	5.5	296	5.5	279.5	5.5	263	5.5	246	6	229	6.5	207	6.5	185	7.5	
ZRB6-CC370	1145	5.57	380	7.0	373	7.0	370.6	7.0	359	7.0	348	7.0	337	7.0	324	7.0	311	7.5	297	8.0	283	8.5	
ZRB6-CC410	1210	4.77	419	8.0	411	8.0	409.5	8.0	402	8.0	389.5	8.0	377	8.0	366	8	355	8	342.5	8.5	330	9	
ZRB6-CC510	1371	3.34	516	11.0	512	11.0	510	11.0	502	11.0	492	10.5	482	10.5	471	10.5	460	10.5	447.5	10.5	435	10.5	

Catalogued performance shown is for Installation Type B: Free Inlet, Ducted Outlet. Catalogued data for each unit listed include the effects of inlet grille, 6 inch outlet and backdraft damper. Listed speed is nominal (RPM). Performance shown is at the actual speed of the test. The sound ratings shown are for loudness values in spherical sones at 1.5 m (5 ft) in a spherical free field calculated per Annex B of AMCA 311. Values shown are for installation type B: free inlet spherical sone levels.

CEILING CAVITY RIGHT ANGLE DISCHARGE | ZRB-CR

- AMCA Air & Sound certified
- Sound levels under one sone available on select models
- UL Listed for UL705 and UL507
- Direct drive, totally enclosed EC motor
- Variable speed control
- All motors with thermal overload protection
- Low profile units available
- Quick access wiring

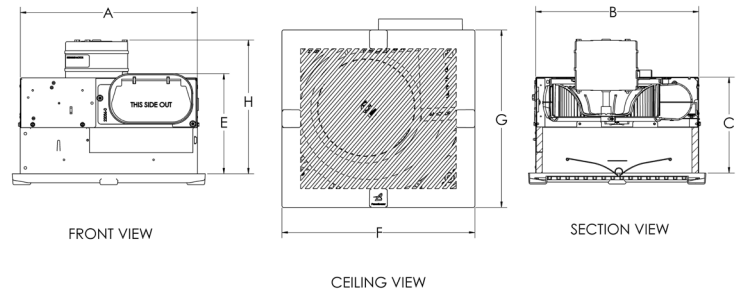

Dimensional Data									
A	B	C	D	E	F	G	H		Est. Shipping Wt. (Lbs.)
14.25	13.10	7.70	6.73	8.04	15.50	14.25	26 W (1/28 HP)	106 W (1/7 HP)	26 W (1/28 HP) 106 W (1/7 HP)
							7.70	10.74	24.0 31.0

Model	RPM	CFM/ Watt @ .1SP	0.0 SP		.100 SP		.125 SP		.250 SP		.375 SP		.500 SP		.625 SP		.750 SP		.875 SP		1.00 SP		
			CFM	Sones	CFM	Sone	CFM	Sones	CFM	Sones	CFM	Sones	CFM	Sones	CFM	Sones	CFM	Sones	CFM	Sones	CFM	Sones	CFM
ZRB6-CR120	655	15.89	147	1.0	126	0.9	121	1.1	100	1.4	77	2.0											
ZRB6-CR140	685	14.52	160	1.3	141	1.2	137	1.3	117	1.5	85	2.5	66	3.5									
ZRB6-CR150	780	13.53	168	1.5	150	1.4	146	1.4	130	2.0	105	2.5	80	3.5									
ZRB6-CR180	810	11.42	190	2.0	175	2.0	172	2.0	157	2.0	134	2.5	112	3.5	89.5	3.5	67	4.5					
ZRB6-CR210	920	8.94	218	2.5	210	2.5	207	2.5	190	2.5	171	3.0	153	3.5	131	4.0	109	4.5	88	5.0	67	5.5	
ZRB6-CR240	940	9.80	260	3.0	249	3.0	245.5	3.0	228	3.0	206	3.5	184	4.0	153	4.5	122	5	101	5.5	80	6	
ZRB6-CR280	985	8.40	296	4.0	285	4.0	282.3	4.0	269	4.0	253	4.0	237	4.0	216.5	4.5	196	4.5	174.5	5.0	153	5.0	
ZRB6-CR310	1010	7.85	317	4.0	307	4.0	304.5	4.0	292	4.0	276.5	4.5	261	4.5	243.5	5	226	5	209	5	192	5	
ZRB6-CR370	1120	5.76	389	6.0	380	6.0	377.3	6.0	364	5.5	353.5	6.0	343	6.0	328	6.0	313	6.0	299	6.5	285	6.5	

Catalogued performance shown is for Installation Type B: Free Inlet, Ducted Outlet. Catalogued data for each unit listed include the effects of inlet grille, 6 inch outlet and backdraft damper. Listed speed is nominal (RPM). Performance shown is at the actual speed of the test. The sound ratings shown are for loudness values in spherical sones at 1.5 m (5 ft) in a spherical free field calculated per Annex B of AMCA 311. Values shown are for installation type B: free inlet spherical sone levels.

CEILING CAVITY RIGHT TOP DISCHARGE | ZRB-CT

- AMCA Air & Sound certified
- Sound levels under one sone available on select models
- UL Listed for UL705 and UL507
- Direct drive, totally enclosed EC motor
- Variable speed control
- All motors with thermal overload protection
- Low profile units available
- Quick access wiring

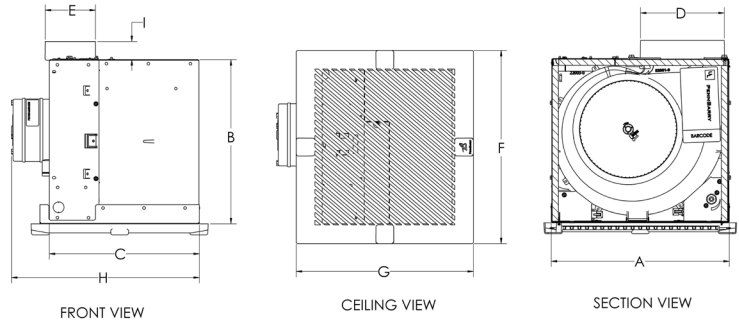

Dimensional Data											
A	B	C	D	E	F	G	H		I	Est. Shipping Wt. (Lbs.)	
14.24	13.18	12.03	6.73	4.04	15.2	14.25	26 W (1/28 HP)	106 W (1/7 HP)	1.45	26 W (1/28 HP)	106 W (1/7 HP)
							12.03	15.1		28.0	35.0

Model	RPM	CFM/ Watt @ .1SP	0.0 SP		.100 SP		.125 SP		.250 SP		.375 SP		.500 SP		.625 SP		.750 SP		.875 SP		1.00 SP		
			CFM	Sones	CFM	Sone	CFM	Sones	CFM	Sones	CFM	Sones	CFM	Sones	CFM	Sones	CFM	Sones	CFM	Sones	CFM	Sones	CFM
ZRB6-CT120	595	16.61	146	0.6	123	0.3	115	0.3	92	0.8	58	2.0											
ZRB6-CT140	665	15.43	161	0.6	140	0.5	133	0.5	111	1.0	81	2.0	55	2.5									
ZRB6-CT150	740	13.92	170	0.9	151	0.8	145	0.8	126	1.2	99	2.0	73	2.5									
ZRB6-CT180	790	12.47	195	1.5	177	1.1	171	1.1	155	1.3	131	2.0	101	2.5	79	3.5	58	4					
ZRB6-CT210	875	9.63	223	2.0	209	2.0	206	2.0	190	2.0	170	2.0	147	3.0	122	3.5	95	4.5	71	5.0	51	5.5	
ZRB6-CT240	965	8.89	271	2.5	262	2.5	259	2.5	244	3.0	226	3.5	207	4.0	178	4.5	149	5	129	5	109	5	
ZRB6-CT280	1000	8.19	291	3.5	283	3.5	280	3.5	267	3.5	250	4.0	232	4.0	213	4.5	194	5.0	172	5.5	149	5.5	
ZRB6-CT310	1055	7.19	322	4.0	310	4.0	307	4.0	291	4.0	276	4.5	261	4.5	241	5	220	5	200	6	179	6.5	
ZRB6-CT370	1145	5.78	385	5.5	376	5.5	374	5.5	361	5.5	350	5.5	339	6.0	326	6.0	313	6.5	298	6.5	283	7.0	
ZRB6-CT410	1210	4.84	424	6.5	414	6.5	413	6.5	405	6.5	393	6.5	381	6.5	368	6.5	355	7	341	7	326	7.5	
ZRB6-CT510	1402	3.36	520	9.0	515	9.0	513	0.0	503	8.5	492	0.0	480	8.5	469	0.0	458	8.5	444	0.0	429	8.5	

Catalogued performance shown is for Installation Type B: Free Inlet, Ducted Outlet. Catalogued data for each unit listed include the effects of inlet grille, 6 inch outlet and backdraft damper. Listed speed is nominal (RPM). Performance shown is at the actual speed of the test. The sound ratings shown are for loudness values in spherical sones at 1.5 m (5 ft) in a spherical free field calculated per Annex B of AMCA 311. Values shown are for installation type B: free inlet spherical sone levels.

INLINE HORIZONTAL DISCHARGE | ZRB-LD

- AMCA Air & Sound certified
- Sound levels under one sone available on select models
- UL Listed for UL705 and UL507
- Direct drive, totally enclosed EC motor
- Variable speed control
- All motors with thermal overload protection
- Low profile units available
- Quick access wiring

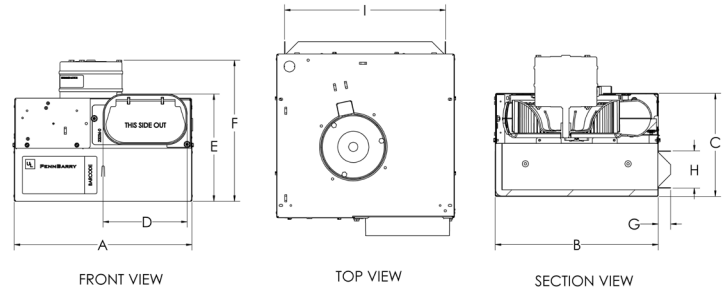

Dimensional Data											
A	B	C	D	E	F		G	H	I	Est. Shipping Wt. (Lbs.)	
14.29	13.10	8.25	6.73	8.59	26 W (1/28 HP)	106 W (1/7 HP)	1.00	2.97	12.94	26 W (1/28 HP)	106 W (1/7 HP)
					8.25	11.29				24.0	31.0

Model	RPM	CFM/ Watt @ .1SP	0.0 SP		.100 SP		.125 SP		.250 SP		.375 SP		.500 SP		.625 SP		.750 SP		.875 SP		1.00 SP			
			CFM	Sones	CFM	Sone	CFM	Sones	CFM	Sones	CFM	Sones	CFM	Sones	CFM	Sones	CFM	Sones	CFM	Sones	CFM	Sones	CFM	Sones
ZRB6-LD140	705	14.47	163	0.7	142	0.6	136	0.7	115	1.2	84	2.0	63	3.0										
ZRB6-LD150	770	13.17	173	0.9	155	0.8	151	0.9	133	1.2	104	2.0	78	3.0	56	3.5								
ZRB6-LD180	860	11.00	208	1.5	195	1.5	192	1.5	176	1.5	151	2.0	121	3.0	95	3.5	76	4.5						
ZRB6-LD220	925	8.49	237	2.0	226	2.0	221	2.0	203	2.0	185	2.5	163	3.0	135	3.5	112	4.0	93	4.5				
ZRB6-LD250	1025	8.96	270	2.5	258	3.0	255	3.0	237	3.0	217	3.0	197	3.0	169	3.5	141	4	120	4.5	98	5		
ZRB6-LD280	1000	8.05	284	3.0	278	3.0	276	3.0	263	3.5	246	3.5	228	3.5	206	3.5	183	4.0	164	4.5	144	5.0		
ZRB6-LD310	1090	7.03	328	4.0	317	4.0	314	4.0	299	4.0	286	4.0	272	4.0	255	4.5	237	4.5	221	4.5	204	5		
ZRB6-LD370	1195	5.31	383	5.5	375	5.5	374	5.5	367	5.5	353	5.5	339	5.0	326	5.5	312	5.5	298	5.5	284	5.5		

Catalogued performance shown is for Installation Type B: Free Inlet, Ducted Outlet. Catalogued data for each unit listed include the effects of inlet grille, 6 inch outlet and backdraft damper. Listed speed is nominal (RPM). Performance shown is at the actual speed of the test. The sound ratings shown are for loudness values in spherical sones at 1.5 m (5 ft) in a spherical free field calculated per Annex B of AMCA 311. Values shown are for installation type B: free inlet spherical sone levels.

INLINE RIGHT ANGLE DISCHARGE | ZRB-RA

- AMCA Air & Sound certified
- Sound levels under one sone available on select models
- UL Listed for UL705 and UL507
- Direct drive, totally enclosed EC motor
- Variable speed control
- All motors with thermal overload protection
- Low profile units available
- Quick access wiring

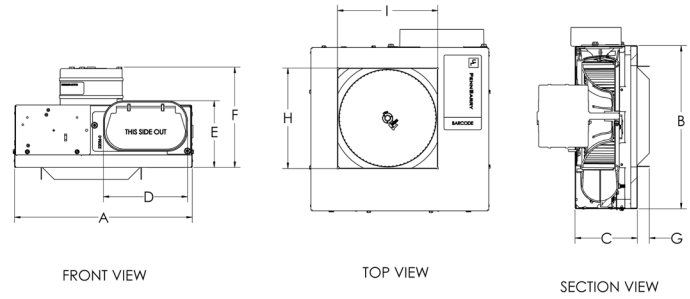

Dimensional Data											
A	B	C	D	E	F		G	H	I	Est. Shipping Wt. (Lbs.)	
14.29	13.10	5.01	6.73	5.34	26 W (1/28 HP)	106 W (1/7 HP)	1.00	8.07	8.07	26 W (1/28 HP)	106 W (1/7 HP)
					5.01	8.04				22.0	29.0

Model	RPM	CFM/ Watt @ .1SP	.0.0 SP		.100 SP		.125 SP		.250 SP		.375 SP		.500 SP		.625 SP		.750 SP		.875 SP		1.00 SP		
			CFM	Sones	CFM	Sone	CFM	Sones	CFM	Sones	CFM	Sones	CFM	Sones	CFM	Sones	CFM	Sones	CFM	Sones	CFM	Sones	CFM
ZRB6-RA120	575	17.62	146	0.6	126	0.7	118	0.7	92	1.5	56	2.5											
ZRB6-RA140	660	15.60	164	1.0	143	1.0	138	1.0	111	1.5	85	2.5	57	4.0									
ZRB6-RA150	710	14.42	171	1.2	152	1.1	147	1.2	127	1.5	100	2.5	71	3.5	48	4.5							
ZRB6-RA180	790	12.03	192	1.5	175	1.5	169	1.5	152	2.0	131	2.5	107	3.5	82	4.5	57	5					
ZRB6-RA220	870	9.27	233	2.5	218	2.5	214	2.5	200	2.5	180	3.0	158	3.5	131	4.0	105	5.0	84	5.5			
ZRB6-RA250	960	10.07	269	3.0	249	3.0	246.3	3.0	233	3.0	211	3.5	189	4.0	158.5	4.5	128	5	103	5.5	78	6	
ZRB6-RA280	985	8.41	295	3.5	286	3.5	283.5	3.5	271	3.5	253.5	4.0	236	4.0	214	4.5	192	5.0	169	5.5	146	6.0	
ZRB6-RA310	1010	8.05	316	4.0	307	4.0	304.3	4.0	291	4.0	276	4.0	261	4.5	244.5	5	228	5	210.5	5.5	193	5.5	
ZRB6-RA370	1100	5.72	388	6.0	378	6.0	375.5	6.0	363	5.5	352.5	5.5	342	6.0	325	6.0	308	6.0	296	6.0	284	6.5	

Catalogued performance shown is for Installation Type B: Free Inlet, Ducted Outlet. Catalogued data for each unit listed include the effects of inlet grille, 6 inch outlet and backdraft damper. Listed speed is nominal (RPM). Performance shown is at the actual speed of the test. The sound ratings shown are for loudness values in spherical sones at 1.5 m (5 ft) in a spherical free field calculated per Annex B of AMCA 311. Values shown are for installation type B: free inlet spherical sone levels.

ENGINEERING SPECIFICATIONS

Model
ZR = Ceiling Fan

Unit Size
B

Nominal CFM (@ 0.1 ESP)
A = 120
C = 140
D = 150
F = 180
H = 210
J = 220
L = 240
N = 250
P = 280
Q = 310
T = 370
W = 410
Y = 510

Discharge Configuration
CC = Ceiling Cavity Cassette
CR = Ceiling Cavity Right Angle Discharge
CT = Ceiling Cavity Top Discharge
LD = Inline Horizontal Discharge*
RA = Inline Right Angle Discharge*
* Grille option not available in these configurations

Motor Enclosure
1 = TE w/overload

Horsepower
0.035 = 1/28 (26W)
0.140 = 1/7 (106W)

Voltage
B = 110V/1PH/50HZ
C = 115V/1PH/60HZ
D = 120V/1PH/60HZ
F = 208V/1PH/60HZ
H = 220V/1PH/50HZ
K = 230V/1PH/60HZ
M = 240V/1PH/60HZ**
P = 277V/1PH/60HZ +
** Available only on 1/7 HP motor option
+ To use 277 V with 26 W motor option, use voltage code "D" and select transformer

Outlet Duct
0 = None
4 = 4" outlet duct
6 = 6" outlet duct

Damper
0 = None
FD = Ceiling radiation damper*
* Only available for CC, CR and CT discharge configurations; not available in combination with lighted grilles

Curb Cap
0 = None
C = Curb mounted
F = Flat roof
S = Sloped roof
W = Wall Mount

Brick Vent
0 = None
B = Brick vent

Grille
0 = None**
A = Full diagonal – plastic
B = Patchwork diagonal – plastic
C = ArtDeco – plastic
D = Perforated aluminum*
E = Lighted ArtDeco LED 12 Watt*
F = Lighted panel LED 25 Watt
* Grille not available with CC discharge configuration
** Grille option not available for LD and RA discharge configurations

Vibration Isolation
0 = None
R = Rubber hanger*
* Vibration option for LD, CR and CT discharge configurations only

Transformer
0 = None
B = 277Vx115V*
* Transformer option only required for 277V with 1/28 (26W) motor option

Motion Sensor
0 = None
C = Ceiling mount motion sensor
W = Wall mount motion sensor

Humidity Sensor
0 = None
H = Humidity sensor

Air Filter
0 = None
A = Washable air filter*
* Filter available only with CR and CT discharge configurations

Mounting Accessories
0 = None
H = Housing brackets*
M = Mounting channel assembly+
* Housing bracket included in LD configuration
+ Mounting channels included on CC, CR, and CT configurations

Zephyr Revolution (ZRB)

Fan housings shall be 18 ga galvanized steel and include integral backdraft damper which shall be chatter proof. Grille face for ceiling fans shall be of aerodynamic appliance white design. Fans shall be provided with cord, plug, and receptacle inside the housing wheel. Fan motors shall be multi-speed, direct drive ECM and have thermal overload protection.

Each fan shall bear the AMCA Licensed Rating -Seal for Air and Sound Performance and shall be UL705 and UL507 listed for use over bathtubs and showers.

From office buildings and manufacturing plants to schools, hospitals and other commercial applications, PennBarry is defining the next level of air movement for the industry. Contact your PennBarry representative or visit PennBarry.com to learn more about why the Zephyr Revolution should be your first choice for reliable and efficient airflow management.

Find out more about the full line of PennBarry fan products for commercial and industrial applications at www.PennBarry.com.



Moving Your Way

PennBarry | www.pennbarry.com | pennbarrysales@pennbarry.com | Tel: 972.212.4700 | Fax: 972.212.4702

PennBarry reserves the right to make changes at any time, without notice, to models, construction, specifications, options or availability. This bulletin illustrates the appearance of PennBarry products at the time of publication. View the latest updates on the PennBarry website.

© Copyright 2017 PennBarry. All Rights Reserved. MAY 2017