

SR-502B

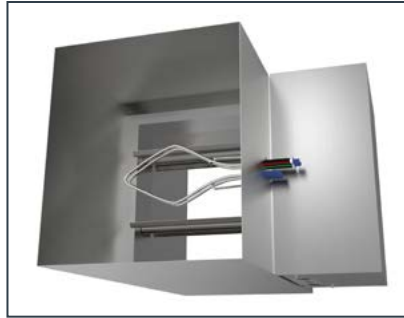

SR-502D

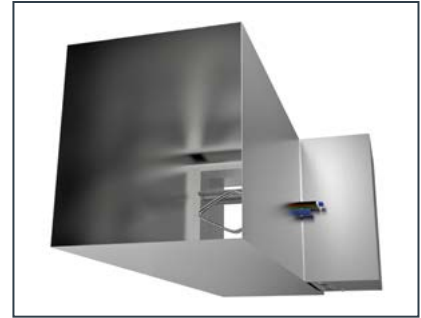

SR-502EX

## SR-500 SQUARE RETROFIT AIR TERMINAL UNITS

The METALAIRE series SR-500 products are designed to fit into existing low pressure square or rectangular duct systems. The SR-500 is available in three versions: Model 502B is a slip-in unit for existing ductwork. Model 502D is designed for use in 24" duct sections as a basic VAV terminal. Model 502EX is a 46" exhaust unit with inlet sound attenuator and flow sensor.

### STANDARD FEATURES

- SR-500 is available in multiple sizes up to 24" x 36" to handle 100–18,000 CFM.
- Minimum 20 ga. galvanized steel casing.
- Galvanized steel damper with minimum 20 ga. 3V style opposed blades.
- Optional blade seals and jamb seals available.
- Optional factory calibrated controls per each job requirement.
- Multi-quadrant, averaging flow sensor for highly accurate (+/-5%) flow readings with varying inlet duct configurations after certified balancer has balanced terminal.
- Externally accessible, steel balancing taps.
- External control cabinet with offset mounting plate as standard.

## SR-500 SQUARE RETROFIT

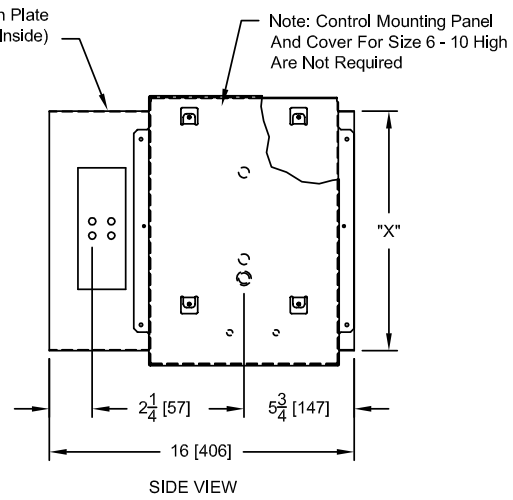
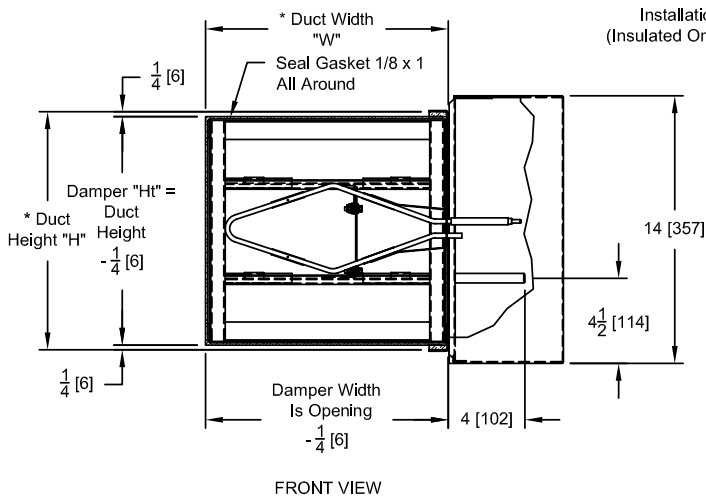
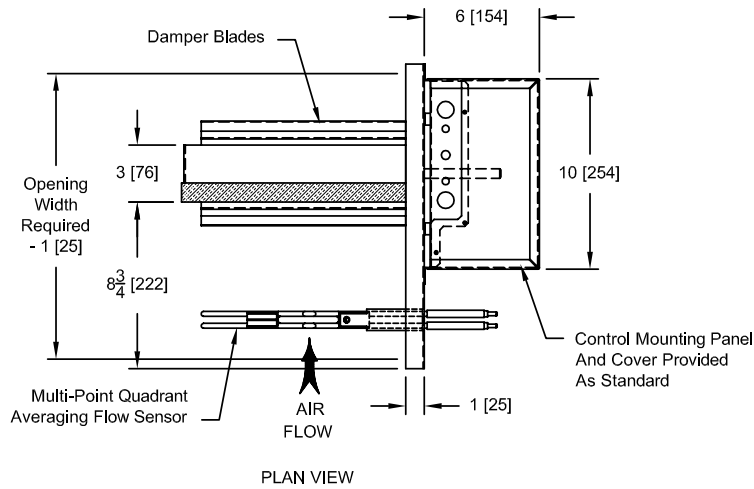

Duct Height "H"		Duct Width "W"	
Min.	Max.	Min.	Max.
6 (152)	24 (610)	10 (254)	36 (914)

1. X = Nominal duct height + 1/2 (8" Minimum)
2. Installation plate material – 20 ga. steel
3. Dampers available in 1" increments between minimum / maximum limits.
4. When ordering, specify nominal duct width (W) first, then height (H).  
Example: Series SR-500 20" x 12" = 20" wide x 12" high unit.

## SR-502-D RECTANGULAR RETROFIT

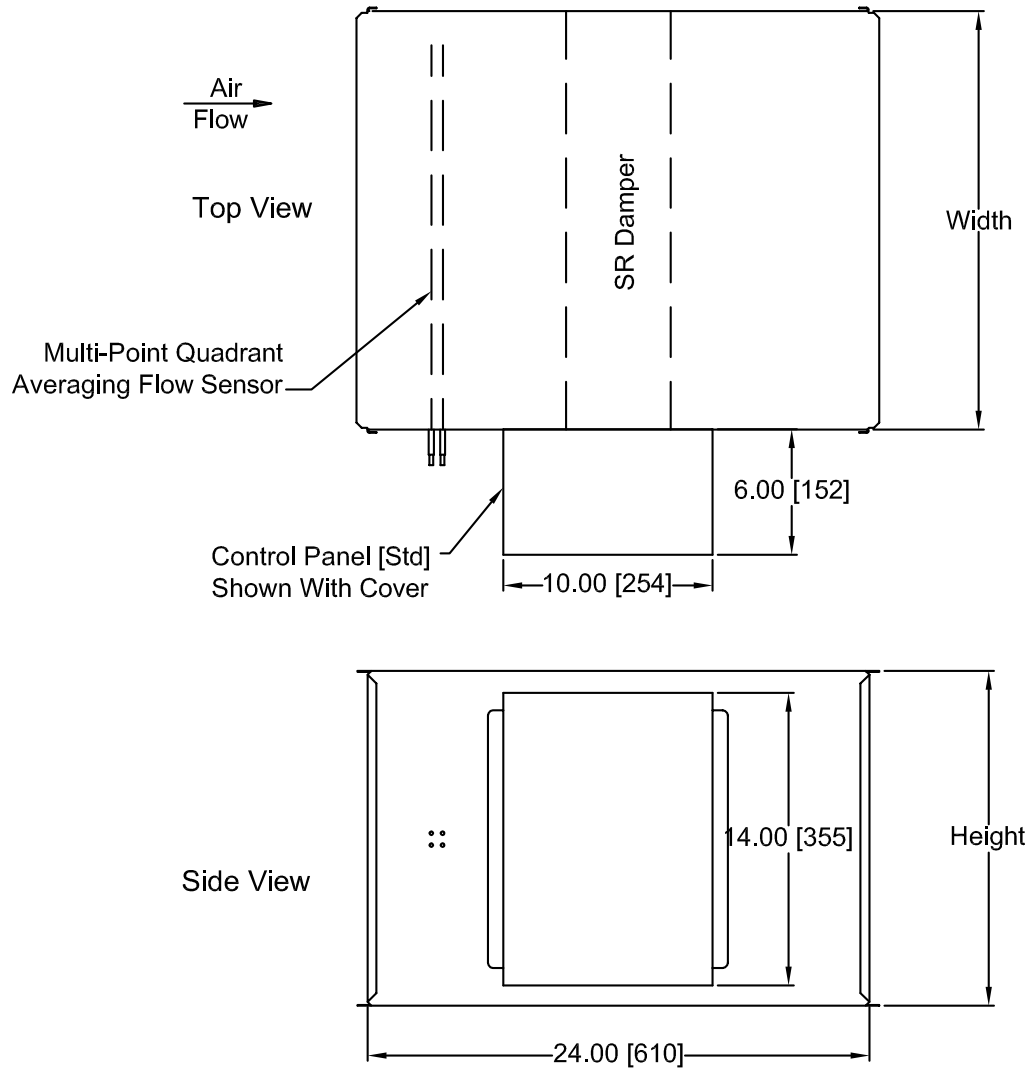

*The standard location for control panel is Right Hand on Model SR-502-D.  
Looking in the direction of airflow, the control panel is on the right.*

## SR-502-EX SQUARE RETROFIT WITH INLET SOUND ATTENUATOR FOR EXHAUST APPLICATIONS

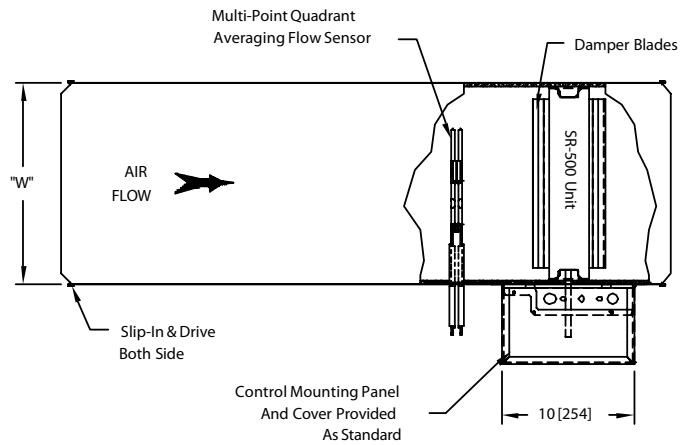

PLAN VIEW

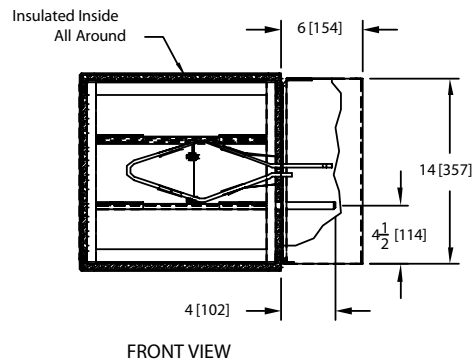

FRONT VIEW

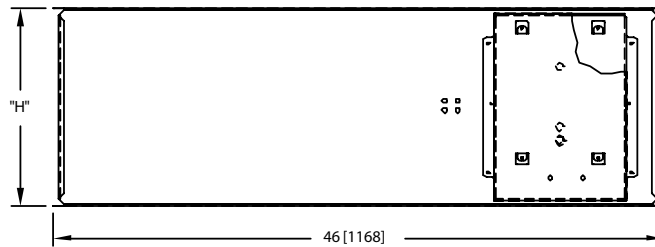

SIDE VIEW

Duct Height "H"		Duct Width "W"	
Min.	Max.	Min.	Max.
6 (152)	24 (610)	10 (254)	36 (914)

## SR-500 CONTROL SEQUENCE OFFERINGS



### PPD-PNEUMATIC PRESSURE DEPENDENT

- 410N Direct Acting / Normally Closed (DA / NC)
- 412N Reverse Acting / Normally Open (RA / NO)



### PPI-PNEUMATIC PRESSURE INDEPENDENT

- 414M Direct Acting / Normally Closed (DA / NC)
- 415M Direct Acting / Normally Open (DA / NO)
- 416M Reverse Acting / Normally Closed (RA / NC)
- 417M Reverse Acting / Normally Open (RA / NO)
- 440M Static Pressure Control



### EPD-ELECTRIC PRESSURE DEPENDENT

- 452 Cooling Only
- 453 Cooling with Reheat
- 456 Static Control
- 457 Actuator Only



### API-ANALOG PRESSURE INDEPENDENT

- 460 Cooling Only
- 461 Cooling with Heat
- 464 Night Setback / Morning Warm-up
- 465 Heating / Cooling Changeover
- 473 Static Pressure Control



### DDC-DIRECT DIGITAL CONTROL

#### BACnet

- 490 Cooling Only
- 491 Cooling or Heating
- 492 Hot Water Reheat
- 493-E Electric Reheat

Refer to page ACC-24 for a complete description of all control sequences