

DIBD2SS CURTAIN TYPE DYNAMIC FIRE DAMPERS 1½ HOUR UL555 RATED FOR USE IN DYNAMIC OR STATIC SYSTEMS

APPLICATION

Ruskin Model DIBD2SS is a 1½ hour UL classified dynamic (fans on) or static (fans off) curtain style fire damper for use in HVAC systems that remain in operation during a fire. Fire dampers used for the protection of openings in walls, partitions, or masonry floors with fire resistance ratings of less than 3 hours and shall have a 1½ hour fire protection rating. The DIBD2SS can be installed vertically in walls or horizontally in masonry floors and is rated for airflow in either direction.

DYNAMIC CLOSURE RATINGS

2000 fpm (10.2 m/s) vertical or horizontal mount on all sizes.

4 in. w.g. (1 kPa) maximum pressure on all sizes.

STANDARD CONSTRUCTION

Frame and Blade Material

Stainless steel (in gauges required by UL listing R-5531).
Available in 304 or 316 stainless steel.

Closure Springs

301 stainless steel constant force type.

Fusible Link

165°F (74°C) is standard. 212°F (100°C) and 285°F (141°C) are available as options.

DAMPER SIZES

See pages 2 - 5 for minimum and maximum UL sizes.

See pages 6 - 9 for construction details on multiple section assemblies.

OPTIONS

- **True Round Fire Damper** - See model FDR25SS
- **SP200** Switch Package to allow remote indication of damper blade position
- **FAST Angles** factory supplied one-side installation. Other angles of various sizes and gauges also available for one-side or two-side installation
- **Factory Sleeves** of various lengths and gauges to ensure field compliance with UL installation requirements
- **MCP** Control panels for monitoring purpose
- **Grille Mounting** See (D)IBD2G or (D)IBD20G models
- **'GA' Grille Access** See (D)IBD2GA models
- **'OW' Out of Wall** See (D)IBD2/OW models

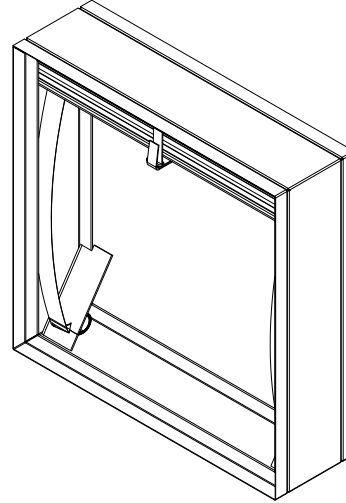

Models DIBD2SS series meet the requirements for fire dampers established by:

- **National Fire Protection Association** NFPA Standards 80, 90A, 92A, 92B, and 101
- **ICC International Building Codes**
- **CSFM California State Fire Marshal**
DIBD2 #3225-0245:0005
- **New York City** MEA 450-06-M



UL CLASSIFIED
UL555 Listing R5531

NOTES:

1. Dimensions shown in parentheses () indicate millimeters.

DAMPER STYLES AND SIZES

A Style

Frame and blades in air stream

Sleeve optional

75 - 85% free area

MINIMUM SIZE 2000 fpm (10.2 m/s)

Vertical Installation – 6"w x 6"h (152 x 152)

Horizontal Installation – 6"w x 6"h (152 x 152)

MAXIMUM SIZE 2000 fpm (10.2 m/s)

Single Section

Vertical Installation – 24"w x 24"h (610 x 610)

Horizontal Installation – 24"w x 24"h (610 x 610)

Multiple Section Assembly

Vertical Installation – 72"w x 48"h (1829 x 1219) or

48"w x 72"h (1219 x 1829) or 90"w x 24"h (2286 x 610)

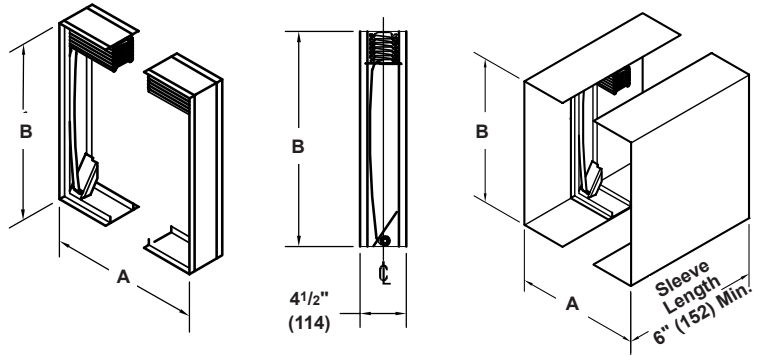

A Style w/o Sleeve

A Style w/Sleeve

Vertical Mount Units 24" x 24" (610 x 610) and Multiple Section Assemblies

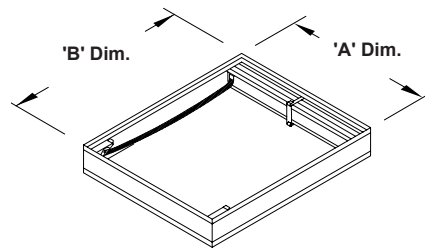

**Horizontal Mount Detail used in
Single Section Assemblies**

Note: See page 7 for overall dimensional information

For round duct sizes 24" and under consider:

FDR25SS True Round Fire Damper 1 1/2 hour UL 555 Listed

Recommended to replace square to round transitions for Increased Performance

APPLICATION

Ruskin FDR25SS is a true round fire damper designed for use in fire rated walls and floors and is the perfect choice when using round duct.

The FDR25SS is rated for maximum velocity of 2,000 fpm (10.2 m/s) and 4" w.g. (1 kPa) static pressure. The integral frame and unique "cinch plate" design provides a low cost, high performing damper.

DAMPER SIZES

MINIMUM SIZE

6" (152) diameter

MAXIMUM SIZE

Vertical/Horizontal – 24" (610) diameter

MATERIAL

- 304 or 316 Stainless Steel Construction



Visit RUSKIN.com for more details

DAMPER STYLES AND SIZES

B Style

Blades out of air stream

Sleeve optional

80 - 90% free area

MINIMUM SIZE 2000 fpm (10.2 m/s)

Vertical Installation – 6"w x 4"h (152 x 102)

Horizontal Installation – 6"w x 4"h (152 x 102)

MAXIMUM SIZE 2000 fpm (10.2 m/s)

Single Section

Vertical Installation – 24"w x 21"h (610 x 533)

Horizontal Installation – 24"w x 21"h (610 x 533)

Multiple Section Assembly

Vertical Installation – 72"w x 45"h (1829 x 1143) or

48"w x 69"h (1219 x 1753) or 90"w x 21"h (2286 x 533)

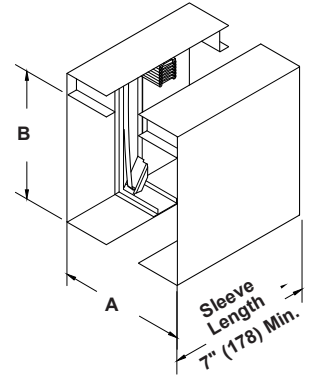

B Style w/Sleeve

A = Duct Width
B = Duct Height
H = Overall Damper Height

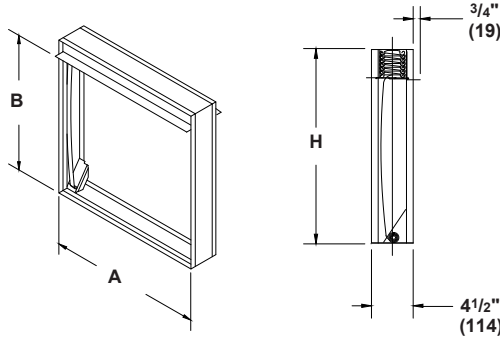

B Style w/o Sleeve

Note: See page 8 for overall dimensional information

BC and WB Style

Blades out of air stream Fully

BC style: fully sealed sleeve

WB style: fully welded sleeve

80 - 90% free area

MINIMUM SIZE 2000 fpm (10.2 m/s)

Vertical Installation – 6"w x 4"h (152 x 102)

Horizontal Installation – 6"w x 4"h (152 x 102)

MAXIMUM SIZE 2000 fpm (10.2 m/s)

Single Section

Vertical Installation – 24"w x 21"h (610 x 533)

Horizontal Installation – 24"w x 21"h (610 x 533)

Multiple Section Assembly

Vertical Installation – 72"w x 45"h (1829 x 1143) or

48"w x 69"h (1219 x 1753) or 90"w x 21"h (2286 x 533)

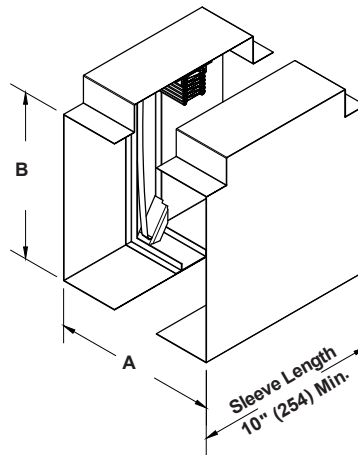

BC & WB Style w/Sleeve

A = Duct Width
B = Duct Height
H = Overall Damper Height

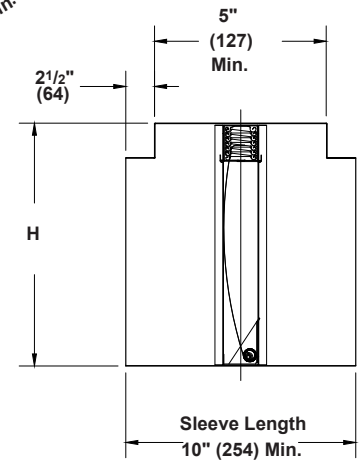

Note: See page 8 for overall dimensional information

DAMPER STYLES AND SIZES

CR AND WR Style – Round Transition

Frame and blades out of air stream

Sleeve required

95 - 100% free area

CR Style – sealed assembly

WR Style – fully welded

MINIMUM SIZE 2000 fpm (10.2 m/s)

Vertical Installation – 4" diameter (102)

Horizontal Installation – 4" diameter (102)

MAXIMUM SIZE 2000 fpm (10.2 m/s)

Single Section

Vertical Installation – 20" diameter (508)

Horizontal Installation – 20" diameter (508)

Multiple Section Assembly

Vertical Installation – 46" diameter (1118)

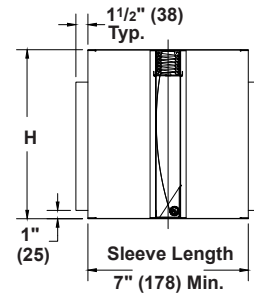
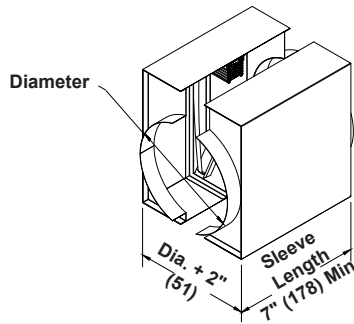

CR Style

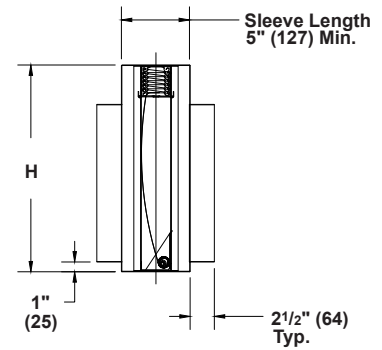

WR Style

D = Diameter
H = Overall Damper Height
X = Blade Package Height

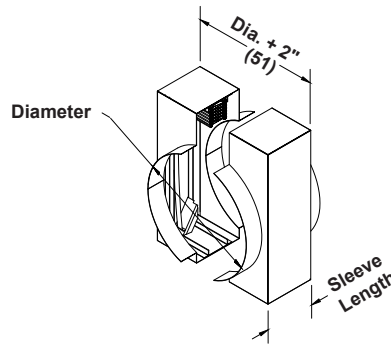

Note: See page 10 for "X" dimension and overall dimensional information

C AND WC Style – Square or Rectangle Transition

Frame and blades out of air stream

Sleeve required

95 - 100% free area

C Style – sealed assembly

WC Style – fully welded

MINIMUM SIZE 2000 fpm (10.2 m/s)

Vertical or Horizontal Installation – 4"w x 3"h (102 x 76)

MAXIMUM SIZE 2000 fpm (10.2 m/s)

Single Section

Vertical Installation – 22"w x 20"h (559 x 508)

Horizontal Installation – 22"w x 20"h (559 x 508)

Multiple Section Assembly

Vertical Installation – 70"w x 44"h (1778 x 1118) or

46"w x 68"h (1168 x 1727) or 88"w x 20"h (2235 x 508)

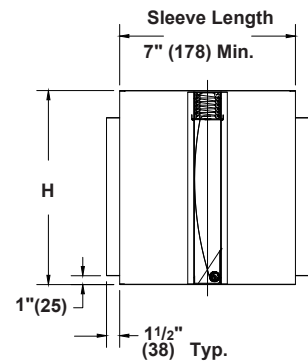
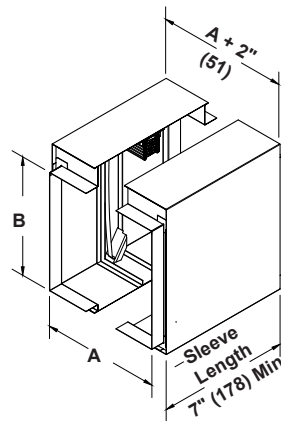

C Style w/Sleeve

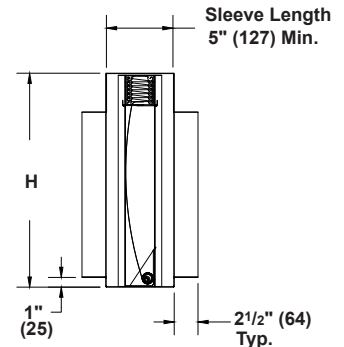

A = Duct Width
B = Duct Height
H = Overall Damper Height

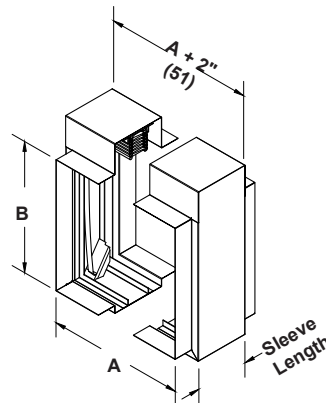

Note: See page 9 for overall dimensional information

WC Style w/Sleeve

DAMPER STYLES AND SIZES

CO AND WO Style – Oval Transition

Frame and blades out of air stream

Sleeve required

95 - 100% free area

CO Style – sealed assembly

WO Style – fully welded

MINIMUM SIZE 2000 fpm (10.2 m/s)

Vertical or Horizontal Installation – 4"w x 3"h (102 x 76)

MAXIMUM SIZE 2000 fpm (10.2 m/s)

Single Section

Vertical Installation – 22"w x 20"h (559 x 508)

Horizontal Installation – 22"w x 20"h (559 x 508)

Multiple Section Assembly

Vertical Installation – 70"w x 44"h (1778 x 1118) or

46"w x 68"h (1168 x 1727) or 90"w x 20"h (2286 x 508)

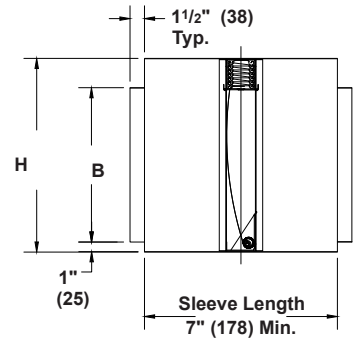
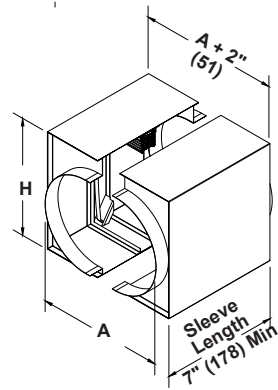

CO Style

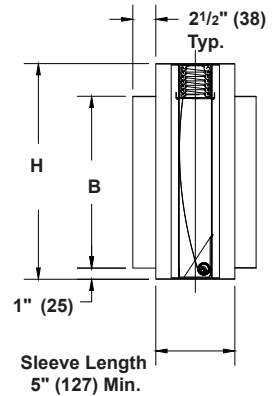

WO Style

A = Duct Width
B = Duct Height
H = Overall Damper Height

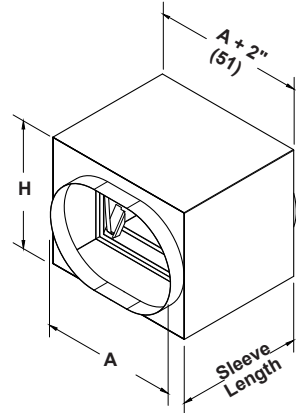

Note: See page 9 for overall dimensional information

LR Style – Round Transition

Round enclosure - frame and blades out of air stream

Sleeve optional non-sealed assembly

95 - 100% free area

MINIMUM SIZE 2000 fpm (10.2 m/s)

Vertical Installation – 4" diameter (102)

Horizontal Installation – 4" diameter (102)

MAXIMUM SIZE 2000 fpm (10.2 m/s)

Single Section

Vertical Installation – 20" diameter (508)

Horizontal Installation – 20" diameter (508)

Multiple Section Assemblies

Not available in style LR. See Style CR for larger assemblies.

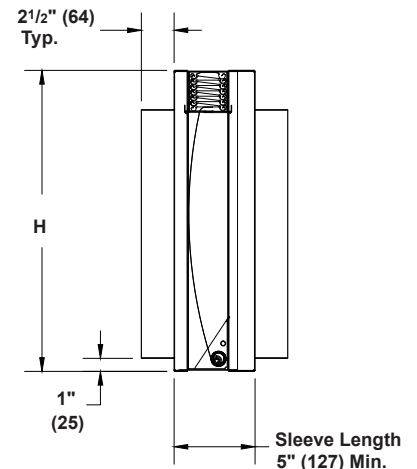
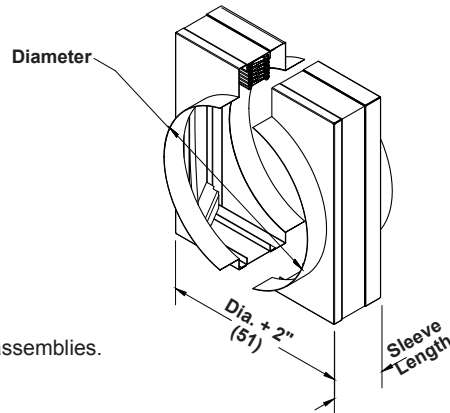

LR Style

D = Diameter
H = Overall Damper Height
X = Blade Package Height

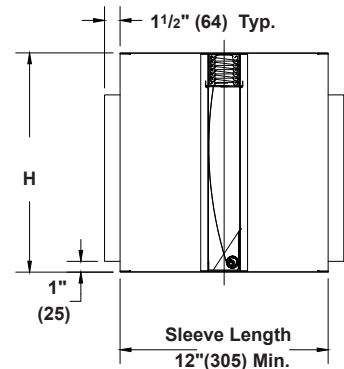
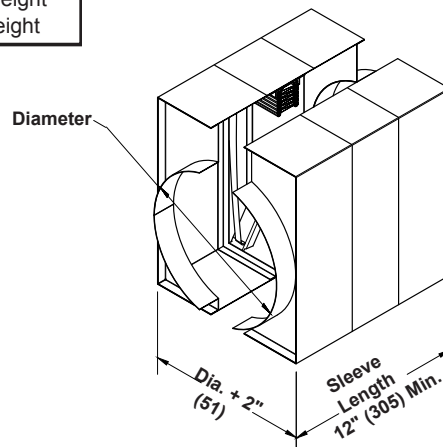

LR Style w/Sleeve

Note: See page 10 for "X" dimension and overall dimensional information

DAMPER STYLES AND SIZES

LO Style – Oval Transition

Frame and blades out of air stream
Sleeve optional non-sealed assembly
95 - 100% free area

MINIMUM SIZE 2000 fpm (10.2 m/s)

Vertical or Horizontal Installation – 4" w x 3" h (102 x 76)

MAXIMUM SIZE 2000 fpm (10.2 m/s)

Single Section

Vertical Installation – 22" w x 20" h (559 x 508)

Horizontal Installation – 22" w x 20" h (559 x 508)

Multiple Section Assembly

Not available in Style LO. See Style CO for larger assemblies

A = Duct Width
B = Duct Height
H = Overall Damper Height

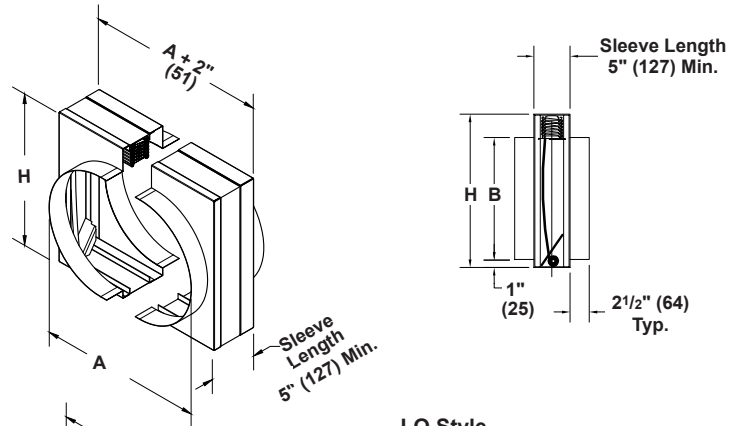

LO Style

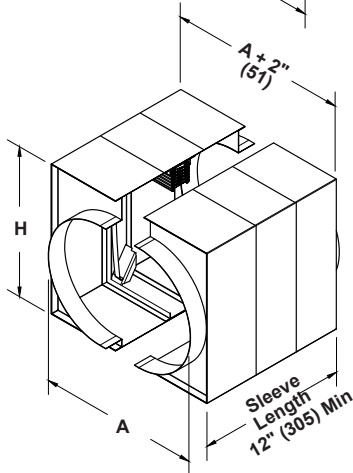

LO Style w/Sleeve

Notes:

1. Transition collars to be sealed (by others).
2. See page 7 for overall dimensional information

R Style – Round Transition

Round enclosure. Blades partially in the air stream
Sleeve optional non-sealed assembly
85 - 95% free area

MINIMUM SIZE 2000 fpm (10.2 m/s)

Vertical Installation – 4" diameter (102)

Horizontal Installation – 4" diameter (102)

MAXIMUM SIZE 2000 fpm (10.2 m/s)

Single Section

Vertical Installation – 22" diameter (559)

Horizontal Installation – 22" diameter (559)

Multiple Section Assemblies

Not available in Style R. See Style CR for larger assemblies

D = Diameter
H = Overall Damper Height

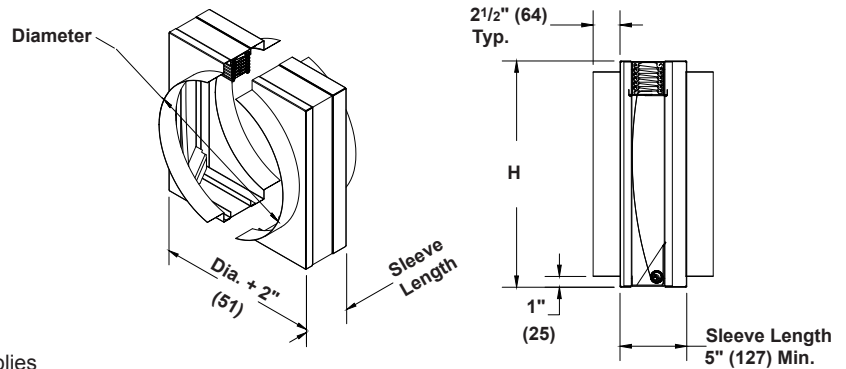

R Style

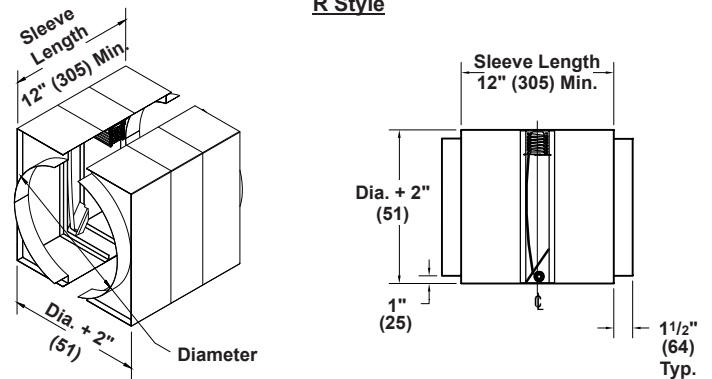

R Style w/Sleeve

Notes:

1. Transition collars to be sealed (by others).
2. See page 7 for overall dimensional information

ASSEMBLY AND DIMENSIONAL INFORMATION

Dampers normally fabricated approximately 1/4" (6) less than given duct dimensions. A (width) and B (height) dimensions shown describe maximum UL Classified sizes. Multiple section damper assemblies ordered without sleeves are shipped in individual sections, for field assembly. Multiple section dampers ordered with factory furnished sleeves are normally shipped in complete assemblies.

DIBD2SS A STYLE DAMPERS

VERTICAL INSTALLATION

Single Section Units 24" (610) wide and 24" (610) high and under	
'B' Damper Height	'x' Dim.
6" (152) thru 10" (254)	1 1/2" (39)
10.01" (255) thru 17" (432)	2" (51)
17.01" (433) thru 21" (533)	2 1/2" (64)
21.01" (534) thru 24" (610)	3" (76)

Multiple Section Wide and Single Section 24" (610) high and under	
'B' Damper Height	'x' Dim.
6" (152) thru 10" (254)	1 1/2" (39)
10.01" (254) thru 17" (432)	2" (51)
17.01" (433) thru 21" (533)	2 1/2" (64)
21.01" (534) thru 24" (610)	3" (76)

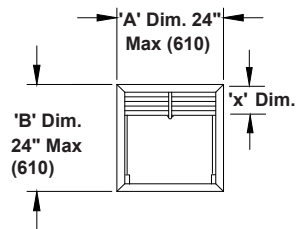
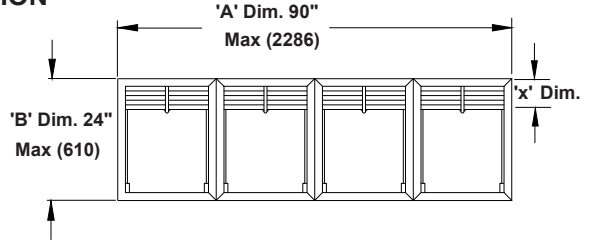

3 Section High Units	
'B' Damper Height	'x' Dim.
48.01" (1220) thru 51" (1295)	2" (51)
51.01" (1296) thru 63" (1600)	2 1/2" (64)
63.01" (1601) thru 72" (1829)	2 3/4" (70)

2 Section High Units	
'B' Damper Height	'x' Dim.
24.01" (611) thru 34" (864)	2" (51)
34.01" (865) thru 42" (1067)	2 1/2" (64)
42.01" (1068) thru 48" (1219)	3" (76)

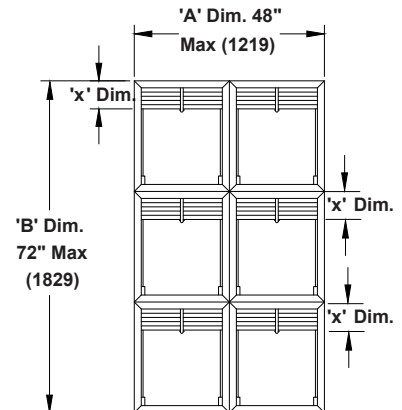
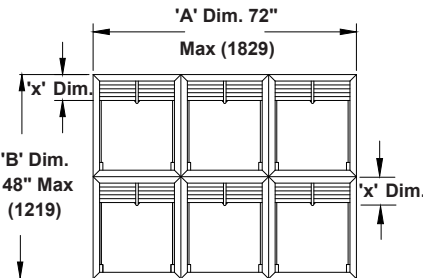

HORIZONTAL INSTALLATION

Single Section Units 24" (610) wide or high and under	
'B' Damper Height	'x' Dim.
6" (152) thru 10" (254)	1 1/2" (39)
10.01" (255) thru 17" (432)	2" (51)
17.01" (433) thru 21" (533)	2 1/2" (64)
21.01" (534) thru 24" (610)	3" (76)

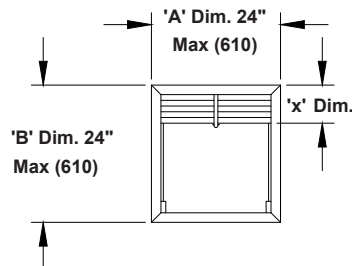

ASSEMBLY AND DIMENSIONAL INFORMATION

B, BC and WB DAMPERS VERTICAL INSTALLATION

'X' dim. + 'B' dim. = 'H' dim.

Multiple Section Wide and High Above 21" (533) thru 69" (1153) high	
'B' Damper Height	'x' Dim.
22" (559) thru 26" (660)	1 ³ / ₄ " (44)
26.01" (661) thru 69" (1753)	2 ³ / ₄ " (70)

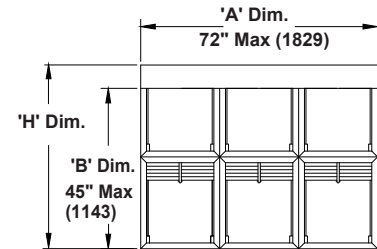
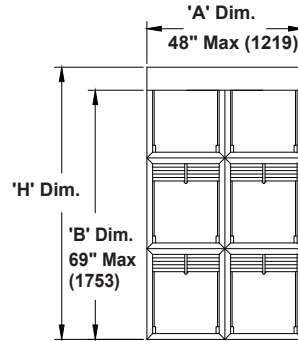
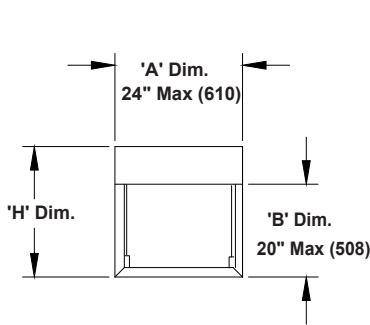

Single Section Units 24" (610) wide or 20" (508) high and under	
'B' Damper Height	'x' Dim.
4" (102) thru 12" (305)	1 ³ / ₄ " (44)
12.01" (306) thru 21" (533)	2 ³ / ₄ " (70)
21.01" (534) thru 32" (813)	3 ³ / ₄ " (95)

Multiple Section Wide and Single Section High 21" (533) and under	
'B' Damper Height	'x' Dim.
4" (102) thru 12" (305)	1 ³ / ₄ " (44)
12.01" (306) thru 21" (533)	2 ³ / ₄ " (70)

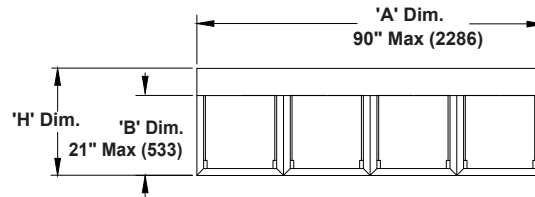

HORIZONTAL INSTALLATION

'X' dim. + 'B' dim. = 'H' dim.

Single Section Units 24" (610) wide and 20" (508) high and under	
'B' Damper Height	'x' Dim.
4" (102) thru 10" (254)	1 ³ / ₄ " (44)
10.01" (255) thru 21" (533)	2 ³ / ₄ " (70)

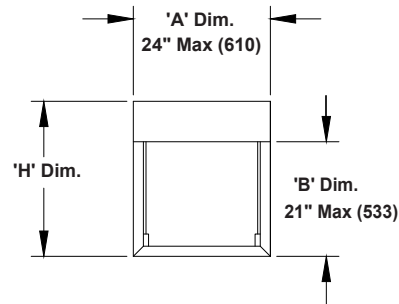

ASSEMBLY AND DIMENSIONAL INFORMATION

C, WC, CO, WO and LO STYLE DAMPERS VERTICAL INSTALLATION

'X' dim. + 'B' dim. = 'H' dim.

Single Section Units 22" (559) wide or 20" (508) high and under	
'B' Damper Height	'x' Dim.
4" (102) thru 11" (280)	2 ³ / ₄ " (70)
11.01" (281) thru 20" (508)	3 ³ / ₄ " (95)

Multiple Section Wide and Single Section High 20" (508) and under	
'B' Damper Height	'x' Dim.
4" (102) thru 11" (280)	2 ³ / ₄ " (70)
11.01" (280) thru 20" (508)	3 ³ / ₄ " (95)

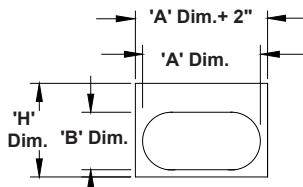
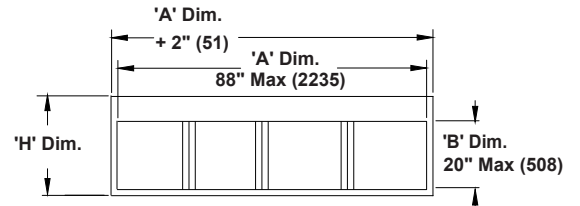
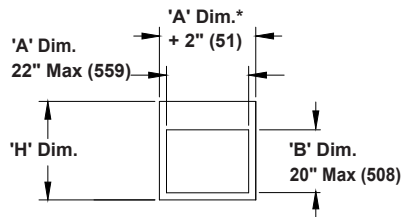

Typical Style CO, WO and LO Construction
Single section shown
(See C & WC construction for max. sizing)
LO Style is limited to single section only.

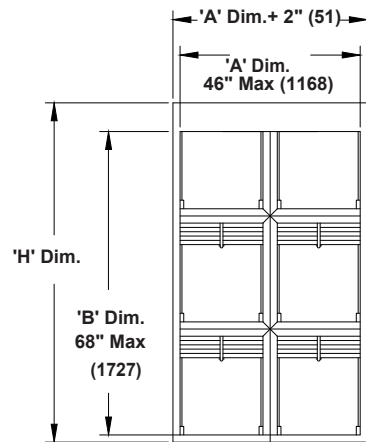

Typical Style C and WC Construction

Multiple Section Wide and High Above 20" (533) thru 68" (1727) high	
'B' Damper Height	'x' Dim.
20.01" (534) thru 25" (635)	2 ³ / ₄ " (70)
25.01" (636) thru 68" (1727)	3 ³ / ₄ " (95)

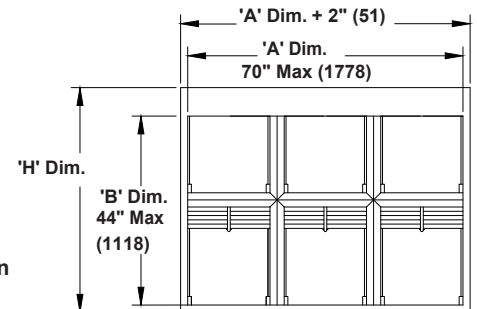

HORIZONTAL INSTALLATION

'X' dim. + 'B' dim. = 'H' dim.

Single Section Units 22" (559) wide and 20" (508) high and under	
'B' Damper Height	'x' Dim.
4" (102) thru 9" (229)	2 ³ / ₄ " (70)
9.01" (230) thru 20" (508)	3 ³ / ₄ " (95)

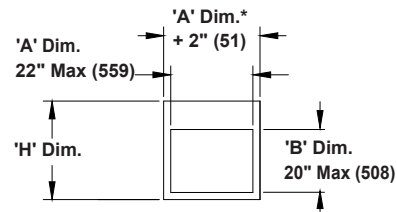

ASSEMBLY AND DIMENSIONAL INFORMATION

CR, WR and LR STYLE DAMPERS VERTICAL INSTALLATION

'X' dim. + 'Dia' dim. = 'H' dim.

SINGLE SECTION HIGH	
'H' DIMENSION	
'B' Damper Height	'x' Dim.
3" (76) thru 11" (279)	2 ³ / ₄ " (70)
11.01" (280) thru 20" (508)	3 ³ / ₄ " (95)

MULTI SECTION HIGH	
'H' DIMENSION	
'B' Damper Height	'x' Dim.
20.01" (509) thru 25" (635)	2 ³ / ₄ " (70)
25.01" (636) thru 46" (1168)	3 ³ / ₄ " (95)

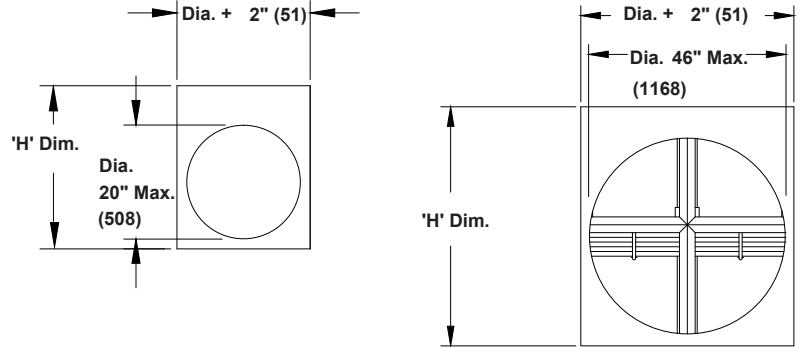

LR Style is limited to single section only.

HORIZONTAL INSTALLATION

'X' dim. + 'Dia' dim. = 'H' dim.

SINGLE SECTION HIGH	
'H' DIMENSION	
'B' Damper Height	'x' Dim.
4" (102) thru 9" (229)	2 ³ / ₄ " (70)
9.01" (230) thru 20" (508)	3 ³ / ₄ " (95)

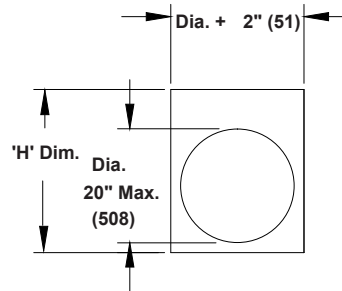

R STYLE DAMPERS VERTICAL AND HORIZONTAL INSTALLATION

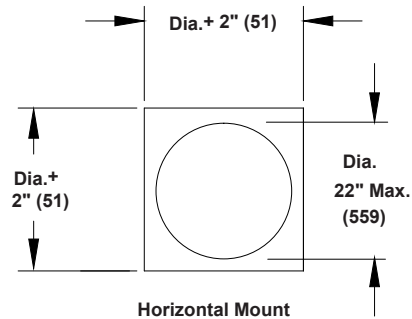
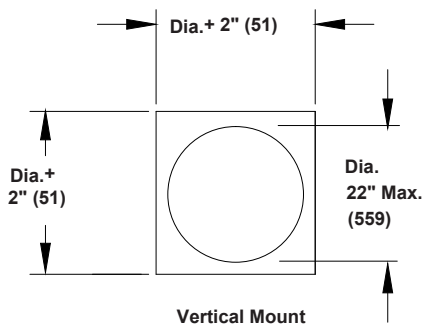

DIBD2SS SUGGESTED SPECIFICATION

Furnish and install at locations shown on the plans, or as described in schedules for curtain type fire dampers suitable for vertical wall or horizontal masonry floor or ceiling. Dynamic fire dampers tested, constructed and labeled in accordance with the latest edition of UL Standard 555. Dampers shall have a fire rating of 1½ hours and shall meet the requirements of the latest edition of NFPA90A. Fire dampers shall be produced in an ISO 9001 certified factory.

Damper frame and blades shall be stainless steel in gauges required by UL listing R5531 installed in a factory mounted sleeve and shipped loose mounting angle. Damper blades shall be steel interlock to provide fire shield in gauges required by UL listing R5531. Closure spring dampers shall be of 301 stainless steel and shall be constant force type.

Each dynamic fire damper shall include a steel sleeve and mounting angles furnished by the damper manufacturer to ensure appropriate installation. Submittal information shall include the fire protection rating, maximum velocity/pressure ratings and the manufac-

turer's UL installation instructions. The dampers shall be installed in accordance with the manufacturer's UL installation instructions. Dynamic fire dampers shall be in all respects equivalent to Ruskin model DIBD2SS.

Each damper shall include a 165°F (74°C), 212°F (100°C) or 285°F (141°C) fusible link and shall be labeled for use in dynamic systems. Dampers labeled for use in static systems only are not permitted. The damper shall be rated for dynamic closure at 2000 fpm (10.2 m/s) and 4 inches w.g. (1 kPa) static pressure and shall be rated to close with airflow in either direction

Dynamic fire dampers shall be Ruskin model DIBD2SS

(Consult www.ruskin.com for electronic version of this "Quick" spec as well as for complete 3-part CSI MasterFormat Specifications)



3900 Dr. Greaves Rd.
Kansas City, MO 64030
(816) 761-7476
FAX (816) 765-8955
www.ruskin.com