

MODEL UP-FALC

The Formations hemmed plenum, model UP-FALC, is designed to connect model FALC to the ducted supply or return system. The UP-FALC is constructed from coated steel and is offered with standard 6" round inlet and oval inlets up to 14". The overall height of the plenum is 10 1/2".

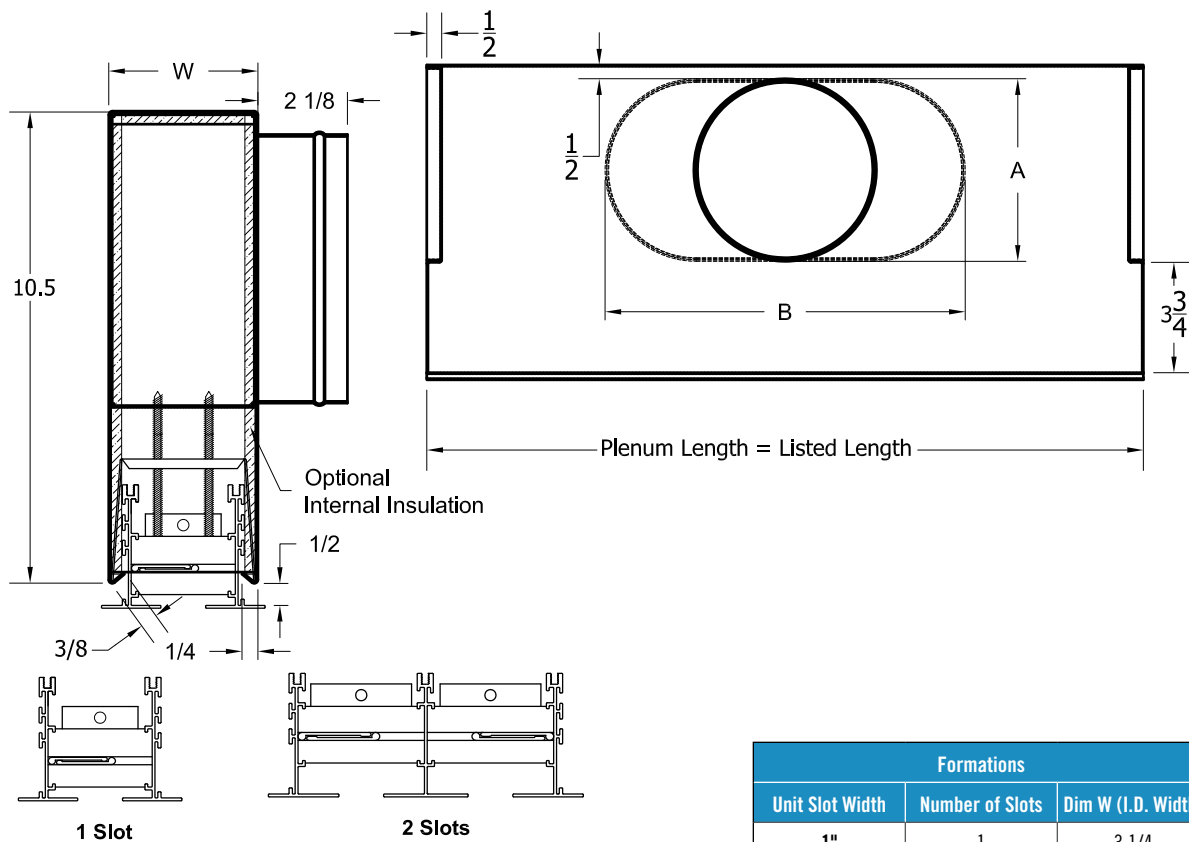

- Available with 1/2" insulation, model UPI-FALC
- Optional external insulation, EI, and internal closed cell insulation, CC, are also available
- Standard inlet sizes 6", 8", 10", 12", 14" or NI (no inlet)
- Available in 24", 36", 48", 60" and 72" lengths



Inlet Chart			
Size	Type	A	B
6	Round	5 7/8	
8	Oval	5 7/8	8 15/16
10	Oval	5 7/8	12 1/16
12	Oval	5 7/8	15 1/4
14	Oval	5 7/8	18 7/16

Formations		
Unit Slot Width	Number of Slots	Dim W (I.D. Width)
1"	1	3 1/4
1.5"	1	4 1/4
2"	1	5 1/4
2.5"	1	6 1/4
3"	1	7 1/4
1"	2	5 5/8
1.5"	2	7 5/8
2"	2	9 5/8
2.5"	2	11 5/8
3"	2	13 5/8

FORMATIONS MODEL SPECIFICATIONS

MODEL UP/UIP

Model	Slot Width	Frame Style	Inlet	# of Slots	Length	End Detail	Pattern Controller	Available Options	
UP-FAL	10-1"	- 1	NI - No Inlet	1	24"	2EB	C - Combo	FODR	Face Operated Damper
UPI-FAL	15-1.5"	- 6	06	2	36"	1EB	S - Straight	ID	Inlet Damper
UP-FALC	20-2"		08		48"	2EC		ROD	Remote Operated Damper
UPI-FALC	25-2.5"		10		60"	1EC		CC	Closed Cell Insualtion
	30-3"		12		72"	MM		EI	External Insulation
			14			00			
						MO			

FORMATIONS MITERED CORNER 90°

FMC - FORMATION MITERED CORNER UNIT

FMCC - FORMATION MITERED CORNER CONCEAL MOUNT UNIT

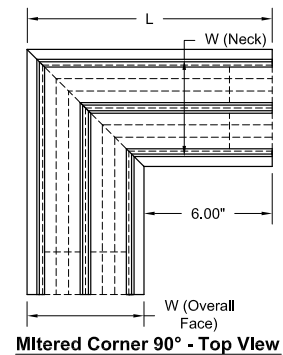
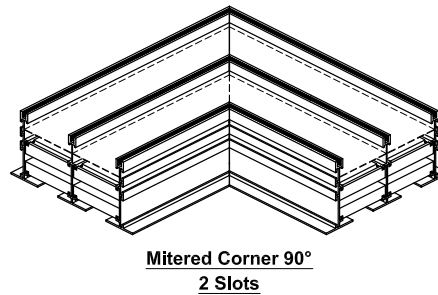
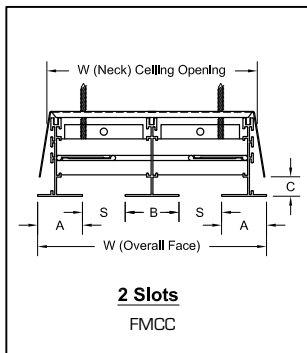
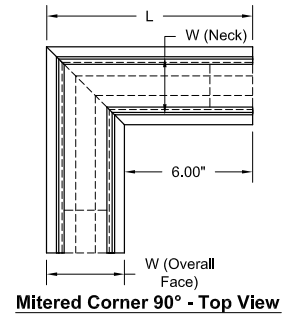
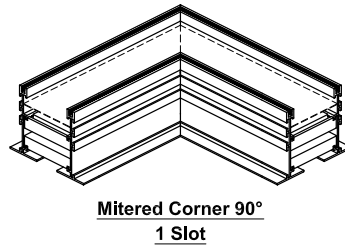
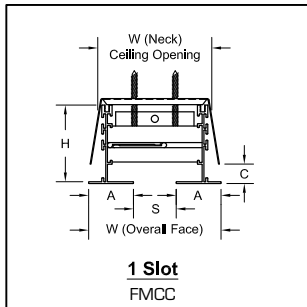

Model: FMC/FMCC 90					
Model	Number of Slots	Slot Width	L	W (Neck)	W (Face OA)
FMC-10/FMCC-10 90	1	1"	9 5/8	2 7/16	3 5/8
FMC-15/FMCC-15 90		1 1/2"	10 5/8	3 7/16	4 5/8
FMC-20/FMCC-20 90		2"	11 5/8	4 7/16	5 5/8
FMC-25/FMCC-25 90		2 1/2"	12 5/8	5 7/16	6 5/8
FMC-30/FMCC-30 90		3"	13 5/8	6 7/16	7 5/8
FMC-10/FMCC-10 90	2	1"	12	4 13/16	6
FMC-15/FMCC-15 90		1 1/2"	14	6 13/16	8
FMC-20/FMCC-20 90		2"	16	8 13/16	10
FMC-25/FMCC-25 90		2 1/2"	18	10 13/16	12
FMC-30/FMCC-30 90		3"	20	12 13/16	14

FORMATIONS MITERED CORNERS 135°

FMC - FORMATIONS MITERED CORNER UNIT

FMCC - FORMATIONS MITERED CORNER CONCEAL MOUNT UNIT

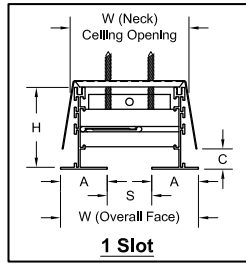

1 Slot

FMCC

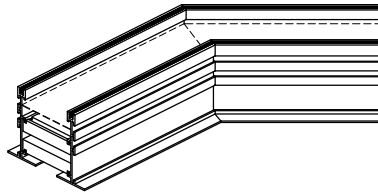

Mitered Corner 135°

1 Slot

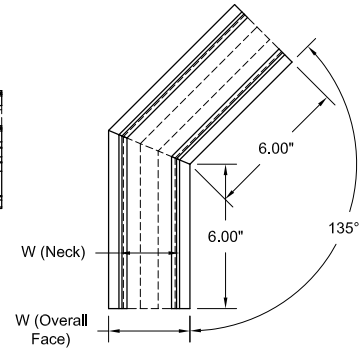

Mitered Corner 135° - Top View

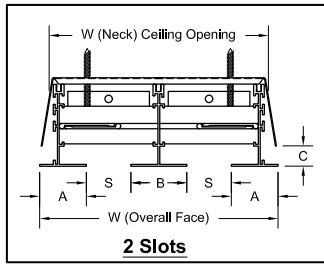

2 Slots

FMCC

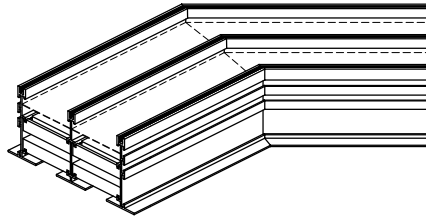

Mitered Corner 135°

2 Slot

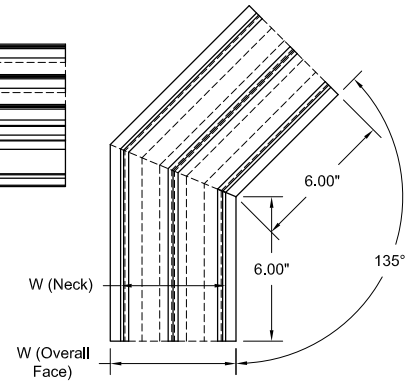

Mitered Corner 135° - Top View

Model: FMC/FMCC 135

Model	Number of Slots	Slot Width	W (Neck)	W (Face OA)
FMC-10/FMCC-10 135	1	1"	2 7/16	3 5/8
FMC-15/FMCC-15 135		1 1/2"	3 7/16	4 5/8
FMC-20/FMCC-20 135		2"	4 7/16	5 5/8
FMC-25/FMCC-25 135		2 1/2"	5 7/16	6 5/8
FMC-30/FMCC-30 135		3"	6 7/16	7 5/8
FMC-10/FMCC-10 135	2	1"	4 13/16	6
FMC-15/FMCC-15 135		1 1/2"	6 13/16	8
FMC-20/FMCC-20 135		2"	8 13/16	10
FMC-25/FMCC-25 135		2 1/2"	10 13/16	12
FMC-30/FMCC-30 135		3"	12 13/16	14

FORMATIONS MITERED UNIT

FAC - FORMATIONS MITERED CROSS UNIT

FACC - FORMATIONS MITERED CROSS CONCEAL MOUNT

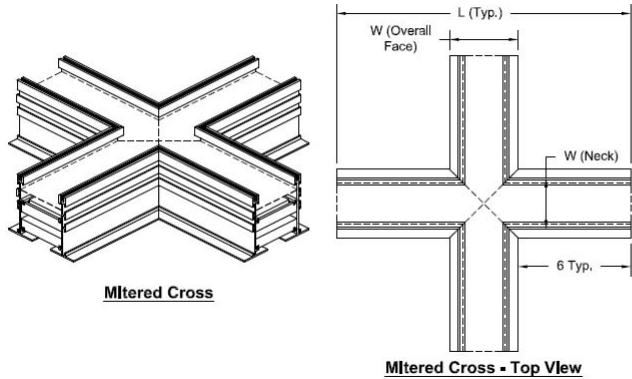

Mitered Cross					
Model	Number of Slots	Slot Width	L	W (Neck)	W (Face OA)
FAC/FACC-10	1	1"	15 5/8	2 7/16	3 5/8
FAC/FACC-15		1 1/2"	16 5/8	3 7/16	4 5/8
FAC/FACC-20		2"	17 5/8	4 7/16	5 5/8
FAC/FACC-25		2 1/2"	18 5/8	5 7/16	6 5/8
FAC/FACC-30		3"	19 5/8	6 7/16	7 5/8
FAC/FACC-10	2	1"	18	4 13/16	6
FAC/FACC-15		1 1/2"	20	6 13/16	8
FAC/FACC-20		2"	22	8 13/16	10
FAC/FACC-25		2 1/2"	24	10 13/16	12
FAC/FACC-30		3"	26	12 13/16	14

FORMATIONS MITERED TEE UNIT

FAT - FORMATIONS MITERED TEE UNIT

FATC - FORMATIONS MITERED TEE CONCEAL MOUNT

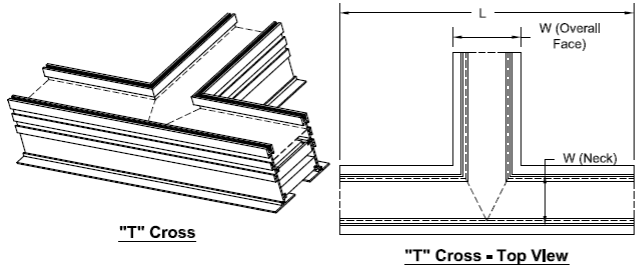

"T" Cross					
Model	Number of Slots	Slot Width	L	W (Neck)	W (Face OA)
FAT/FATC-10	1	1"	15 5/8	2 7/16	3 5/8
FAT/FATC-15		1 1/2"	16 5/8	3 7/16	4 5/8
FAT/FATC-20		2"	17 5/8	4 7/16	5 5/8
FAT/FATC-25		2 1/2"	18 5/8	5 7/16	6 5/8
FAT/FATC-30		3"	19 5/8	6 7/16	7 5/8
FAT/FATC-10	2	1"	18	4 13/16	6
FAT/FATC-15		1 1/2"	20	6 13/16	8
FAT/FATC-20		2"	22	8 13/16	10
FAT/FATC-25		2 1/2"	24	10 13/16	12
FAT/FATC-30		3"	26	12 13/16	14

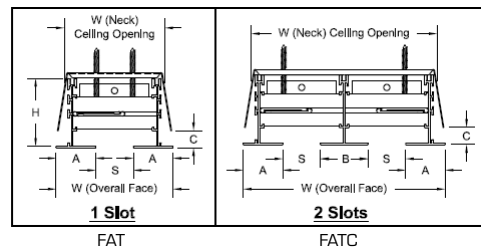

FORMATIONS ACCESSORIES

LIGHT SHIELD

Model: FAR-10 = 1" Slot = Non-Insulation

Model: FAR-15 = 1 1/2" Slot = Non-Insulation

Model: FAR-20 = 2" Slot = Non-Insulation

Model: FAR-25 = 2 1/2" Slot = Non-Insulation

Model: FAR-30 = 3" Slot = Non-Insulation

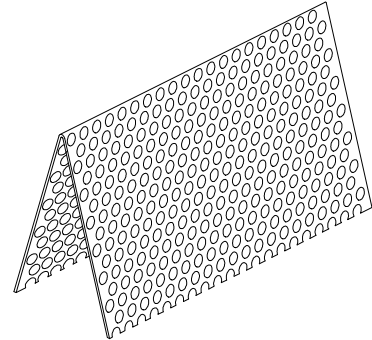
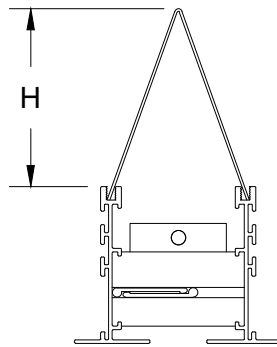

Slot Number	Slot Width	DIM H
1	1	3 1/8
	1 1/2	3 1/8
	2	3 1/8
	2 1/2	3 1/8
	3	3 1/8
Slot Number	Slot Width	DIM H
2	1	2 3/4
	1 1/2	3
	2	3 3/4
	2 1/2	5
	3	5 3/4

FORMATIONS ACCESSORIES

FODR — FACE OPERATED DAMPER ROD

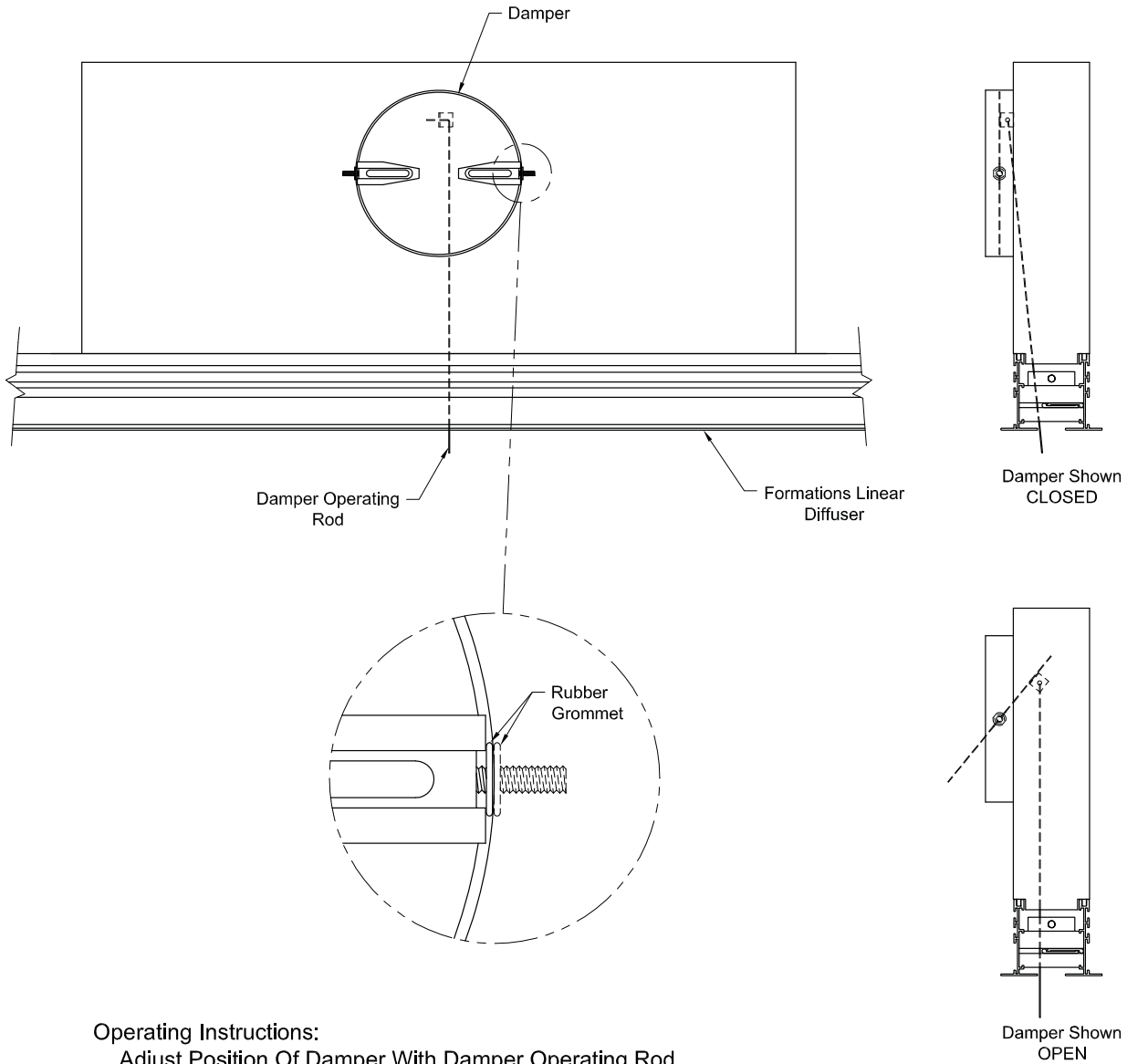

Operating Instructions:
Adjust Position Of Damper With Damper Operating Rod,
Bend Damper Operating Rod to Conceal Behind Face Slot.

FORMATIONS ACCESSORIES

ID - INLET DAMPER

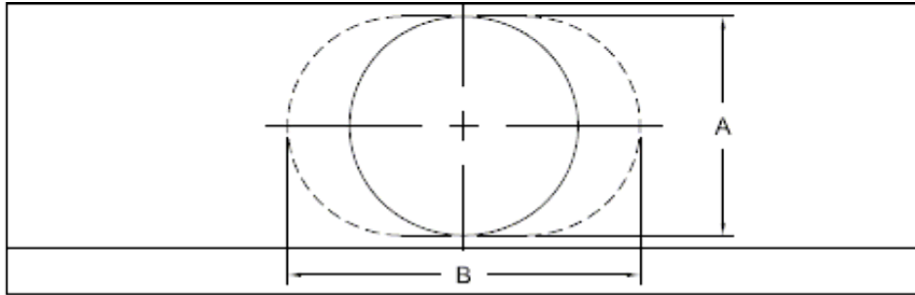

Available Inlets	Round Dim. (A)	Oval Dim. (A x B)
6	5 - 7/8	—
8	—	5 - 7/8 x 8 - 15/16
10	—	5 - 7/8 x 12 - 1/16
12	—	5 - 7/8 x 15 - 1/4
14	—	5 - 7/8 x 18 - 7/16

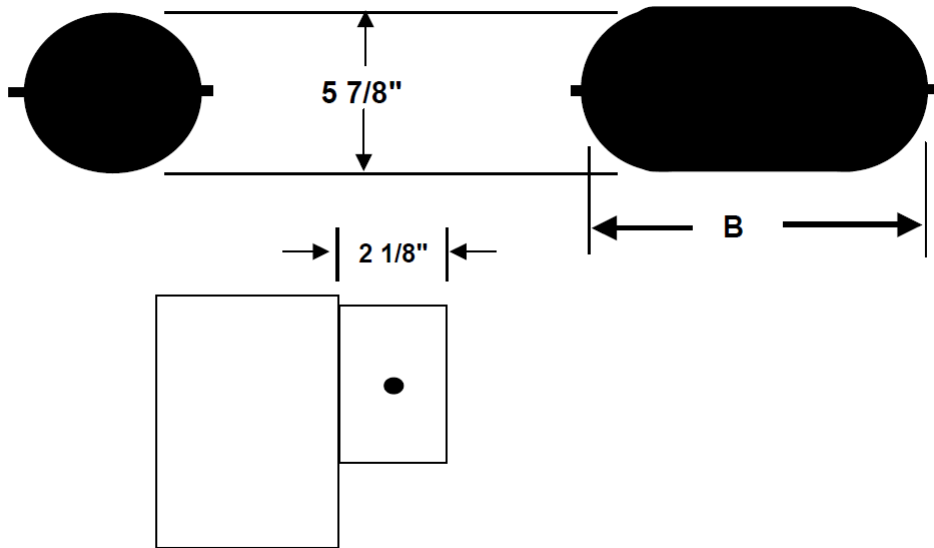

FORMATIONS ACCESSORIES ROD - REMOTE OPERATED DAMPER

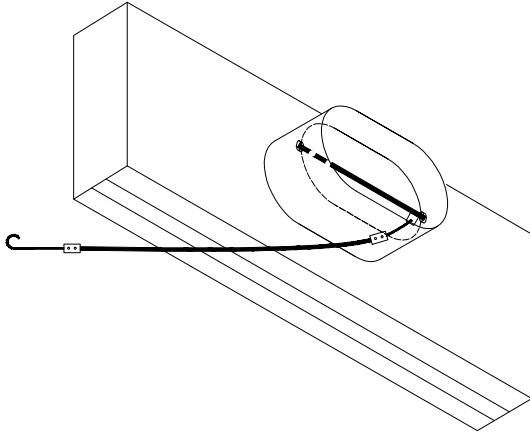

Damper Installed

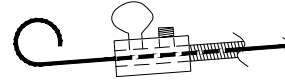

Operator with Locking Coupler

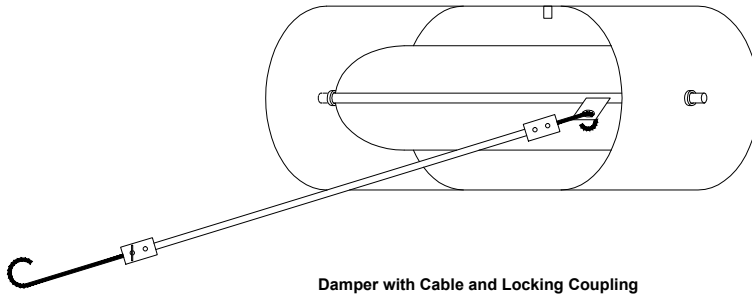

Damper with Cable and Locking Coupling

Available
6"
8"
10"
12"