

Precision LV® Hot Runner Bushings



The Precision LV Hot Runner system is an exclusive large shot-size system with the ability to process engineering and glass-filled resins. Acceptable for crystalline and amorphous materials, this system utilizes gate diameter, gate area cooling and temperature control at the tip to optimize the part quality.

The gate can be sunk into a round depression (referred to as a “recessed gate”) so that the vestige does not protrude above the part surface. The Precision LV is available with three different head styles and four gating options to suit a broad range of applications.

Gating Options for the Precision LV PLUS®



Spreader Needle Gate Insert Tips –

The Gate Insert tips can process all types of commodity and engineering grade resins while maintaining optimal performance, with a ring shaped minimal vestige on the part. Ideal for retrofitting into existing molds that may have larger gates, the tips are available in standard and wear resistant alloys. These tips are capable of processing up to 1900 grams of low viscosity resin (see engineering charts on pages 5, 9, and 13). The tips are also available in three different tip flats to suit specific application requirements. It is recommended to gate directly over the part.



Spreader Needle Collar Gate Tips –

The Collar Gate tips replace the standard Pinpoint style in large volume applications. The improved design leaves no dead spots. These tips are capable of processing up to 1900 grams of low viscosity resin (see engineering charts on pages 5, 9, and 13). The Collar Gate tips are available in standard or wear resistant alloys, and three different tip flats to suit specific application requirements.



Sprue Tips –

Tips can process all types of resins, from commodity to engineering grades, while maintaining optimal performance with minimal vestige. Ideal for retrofitting into existing molds that may have larger gates. Available in standard and wear resistant alloys, these tips are capable of processing up to 4000 grams of low viscosity resin (see engineering charts on pages 5, 9, and 13).



Extra Stock Sprue Tips –

Identical to the Sprue tip, except with extra stock steel at the tip that can be machined to meet customer specific requirements. Ideal for difficult access areas in the part, or for secondary runner applications. Available in standard and wear resistant alloys, these tips are capable of processing up to 4000 grams of low viscosity resin (see engineering charts on pages 5, 9, and 13).

Precision LV[®] Technical Specifications

DIRECT FEED APPLICATIONS

250 LV

All specifications are subject to change without notification.

Head Options

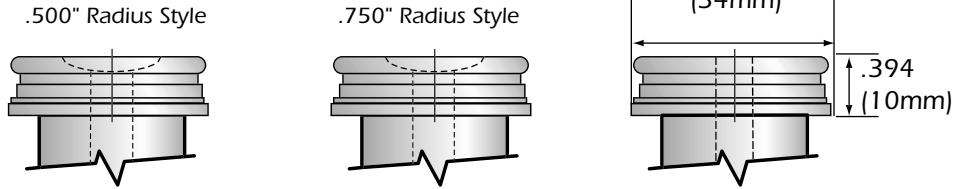

Gating Options / Bushing Dimensions

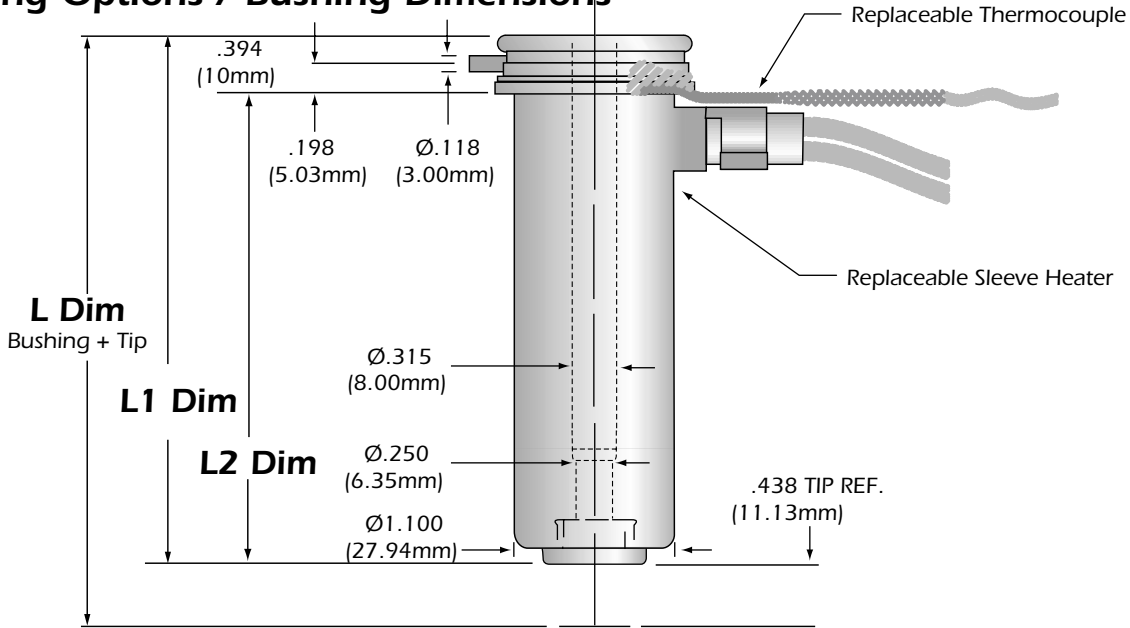

L Dim
Bushing + Tip

L Dim
Note*

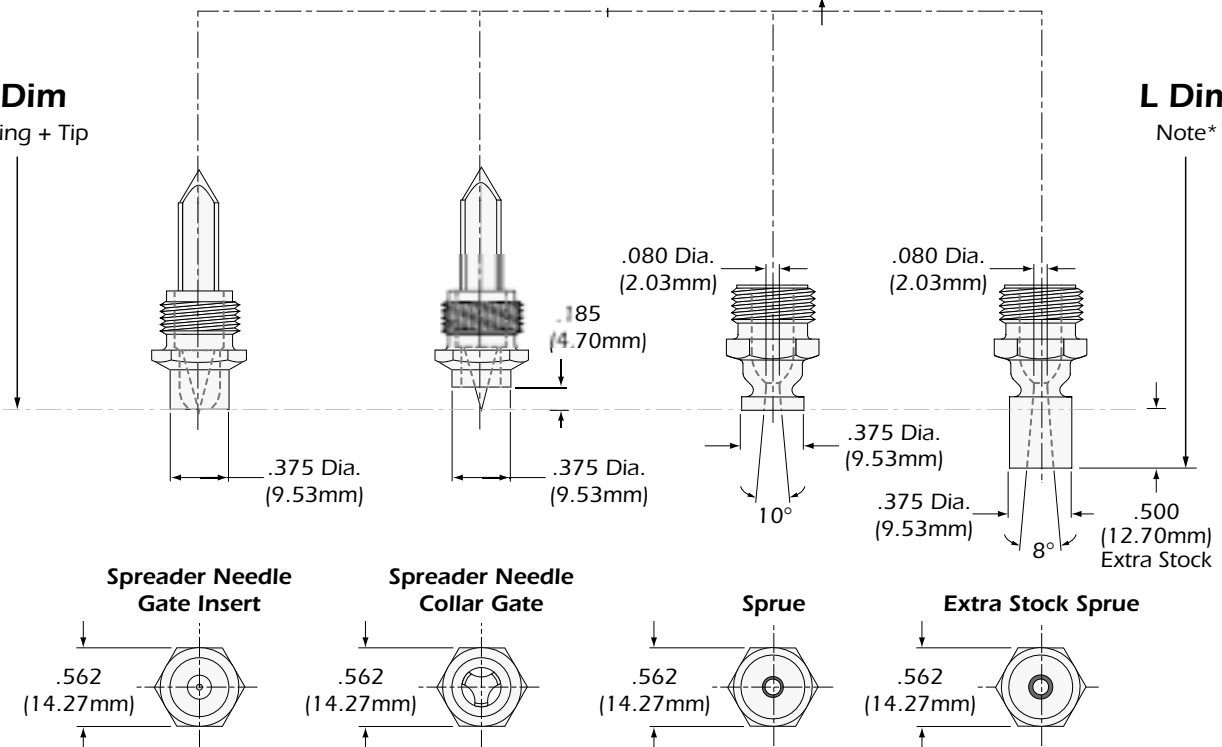

Precision LV® Technical Specifications

DIRECT FEED APPLICATIONS

Chart A

250 LV Ordering Charts

.500

Part Number	L Dim.		L Dim.		Body	Heater	L1 Dim.		L2 Dim.		T/C	Watts
	GI, CG, Sprue		Extra Stock	Sprue								
SV250000	2.563	(65.10)	3.063	(77.80)	MB250000	DS250000	2.125	(53.98)	1.731	(43.97)	MT020083	295
SV250003	3.063	(77.80)	3.563	(90.50)	MB250003	DS250001	2.625	(66.68)	2.231	(56.67)	MT020062	350
SV250006	3.563	(90.50)	4.063	(103.20)	MB250006	DS250002	3.125	(79.38)	2.731	(69.37)	MT020063	350
SV250009	4.063	(103.20)	4.563	(115.90)	MB250009	DS250003	3.625	(92.08)	3.231	(82.07)	MT020064	400
SV250012	4.563	(115.90)	5.063	(128.60)	MB250012	DS250004	4.125	(104.78)	3.731	(94.77)	MT020065	400
SV250015	5.063	(128.60)	5.563	(141.30)	MB250015	DS250005	4.625	(117.48)	4.231	(107.47)	MT020066	460
SV250018	6.063	(154.00)	6.563	(166.70)	MB250018	DS250006	5.625	(142.88)	5.231	(132.87)	MT020067	470
SV250021	7.063	(179.40)	7.563	(192.10)	MB250021	DS250007	6.625	(168.28)	6.231	(158.27)	MT020068	560
SV250024	8.063	(204.80)	8.563	(217.50)	MB250024	DS250008	7.625	(193.68)	7.231	(183.67)	MT020084	650
SV250027	9.063	(230.20)	9.563	(242.90)	MB250027	DS250009	8.625	(219.08)	8.231	(209.07)	MT020085	740
SV250030	10.063	(255.60)	10.563	(268.30)	MB250030	DS250010	9.625	(244.48)	9.231	(234.47)	MT020086	830

.750

SV250001	2.563	(65.10)	3.063	(77.80)	MB250001	DS250000	2.125	(53.98)	1.731	(43.97)	MT020083	295
SV250004	3.063	(77.80)	3.563	(90.50)	MB250004	DS250001	2.625	(66.68)	2.231	(56.67)	MT020062	350
SV250007	3.563	(90.50)	4.063	(103.20)	MB250007	DS250002	3.125	(79.38)	2.731	(69.37)	MT020063	350
SV250010	4.063	(103.20)	4.563	(115.90)	MB250010	DS250003	3.625	(92.08)	3.231	(82.07)	MT020064	400
SV250013	4.563	(115.90)	5.063	(128.60)	MB250013	DS250004	4.125	(104.78)	3.731	(94.77)	MT020065	400
SV250016	5.063	(128.60)	5.563	(141.30)	MB250016	DS250005	4.625	(117.48)	4.231	(107.47)	MT020066	460
SV250019	6.063	(154.00)	6.563	(166.70)	MB250019	DS250006	5.625	(142.88)	5.231	(132.87)	MT020067	470
SV250022	7.063	(179.40)	7.563	(192.10)	MB250022	DS250007	6.625	(168.28)	6.231	(158.27)	MT020068	560
SV250025	8.063	(204.80)	8.563	(217.50)	MB250025	DS250008	7.625	(193.68)	7.231	(183.67)	MT020084	650
SV250028	9.063	(230.20)	9.563	(242.90)	MB250028	DS250009	8.625	(219.08)	8.231	(209.07)	MT020085	740
SV250031	10.063	(255.60)	10.563	(268.30)	MB250031	DS250010	9.625	(244.48)	9.231	(234.47)	MT020086	830

Flat

Part Number	L Dim.		L Dim.		Body	Heater	L1 Dim.		L2 Dim.		T/C	Watts
	GI, CG, Sprue		Extra Stock	Sprue								
SV250002	2.563	(65.10)	3.063	(77.80)	MB250002	DS250000	2.125	(53.98)	1.731	(43.97)	MT020083	295
SV250005	3.063	(77.80)	3.563	(90.50)	MB250005	DS250001	2.625	(66.68)	2.231	(56.67)	MT020062	350
SV250008	3.563	(90.50)	4.063	(103.20)	MB250008	DS250002	3.125	(79.38)	2.731	(69.37)	MT020063	350
SV250011	4.063	(103.20)	4.563	(115.90)	MB250011	DS250003	3.625	(92.08)	3.231	(82.07)	MT020064	400
SV250014	4.563	(115.90)	5.063	(128.60)	MB250014	DS250004	4.125	(104.78)	3.731	(94.77)	MT020065	400
SV250017	5.063	(128.60)	5.563	(141.30)	MB250017	DS250005	4.625	(117.48)	4.231	(107.47)	MT020066	460
SV250020	6.063	(154.00)	6.563	(166.70)	MB250020	DS250006	5.625	(142.88)	5.231	(132.87)	MT020067	470
SV250023	7.063	(179.40)	7.563	(192.10)	MB250023	DS250007	6.625	(168.28)	6.231	(158.27)	MT020068	560
SV250026	8.063	(204.80)	8.563	(217.50)	MB250026	DS250008	7.625	(193.68)	7.231	(183.67)	MT020084	650
SV250029	9.063	(230.20)	9.563	(242.90)	MB250029	DS250009	8.625	(219.08)	8.231	(209.07)	MT020085	740
SV250032	10.063	(255.60)	10.563	(268.30)	MB250032	DS250010	9.625	(244.48)	9.231	(234.47)	MT020086	830

Dimensions are in inches. Millimeters are in parentheses.

* Precision 250 Adaptor from Elite 250 MA010047

* Retaining Ring 100101

Tip Ordering Numbers

Chart B



Gate Style		Spreader Needle Assembly Part Numbers		
Gate Insert	Tip Alloy	0.020" Flat	0.040" Flat	0.070" Flat
	Standard	TP250410	TP250411	TP250412
	Wear Resistant	TP250413	TP250414	TP250415
Gate Style		Spreader Needle Assembly Part Numbers		
Collar Gate	Tip Alloy	0.020" Flat	0.040" Flat	0.070" Flat
	Standard	TP250416	TP250417	TP250418
	Wear Resistant	TP250419	TP250420	TP250421

Chart C

Gate Style	Tip Alloy	Part Number
	Standard	TP250110
	Wear Resistant	TP250111
Gate Style	Tip Alloy	Part Number
	Standard	TP250210
	Wear Resistant	TP250211

All specifications are subject to change without notification.

Hot Runner Systems by Tutco, 500 Gould Drive, Cookeville, TN 38506
Tel (931) 432-4141 • Fax (931) 432-4140 • www.tutco.com

TUTCO
HEATING SOLUTIONS GROUP

Precision LV® Technical Specifications

250 LV Engineering Charts

Chart 1

Tip Alloy Reference: STD = Standard, WR = Wear Resistant

All specifications are subject to change without notification.

Tip Style	Part No.	Alloy	Commodity Resin	Engineering Resin	Glass-Filled Resin
Sprue	TP250110	STD	●	●	
	TP250111	WR	●	●	●
Extra Stock Sprue	TP250210	STD	●	●	
	TP250211	WR	●	●	●
Gate Insert 0.020" Flat	TP250410	STD	●	●	
	TP250413	WR	●	●	●
Gate Insert 0.040" Flat	TP250411	STD	●	●	
	TP250414	WR	●	●	●
Gate Insert 0.070" Flat	TP250412	STD	●	●	
	TP250415	WR	●	●	●
Collar Gate 0.020" Flat	TP250416	STD	●	●	
	TP250419	WR	●	●	●
Collar Gate 0.040" Flat	TP250417	STD	●	●	
	TP250420	WR	●	●	●
Collar Gate 0.070" Flat	TP250418	STD	●	●	
	TP250421	WR	●	●	●

Reference: ● = Recommended

Chart 2

Spreader Needle tips	Resin Viscosity		
	High	Medium	Low
Gate Insert 0.020" Flat	.082" to .114"	.060" to .082"	.040" to .060"
Collar Gate 0.020" Flat	(2.10mm to 2.90mm)	(1.50mm to 2.10mm)	(1.00mm to 1.50mm)
Gate Insert 0.040" Flat	.102" to .134"	.080" to .102"	.060" to .080"
Collar Gate 0.040" Flat	(2.60mm to 3.40mm)	(2.00mm to 2.60mm)	(1.50mm to 2.00mm)
Gate Insert 0.070" Flat	.132" to .164"	.110" to .132"	.090" to .110"
Collar Gate 0.070" Flat	(3.40mm to 4.20mm)	(2.80mm to 3.40mm)	(2.30mm to 2.80mm)
Sprue tips	High	Medium	Low
All Sprue	.081" to .125"*	.081" to .125"*	.081" to .125"*
Part Numbers	(2.10mm to 3.20mm)	(2.10mm to 3.20mm)	(2.10mm to 3.20mm)

Reference: High Viscosity = Melt Flow (0.02 – 6); Medium Viscosity = Melt Flow (7 – 16); Low Viscosity = Melt Flow (16 – up). The values expressed in grams are for reference purposes only. Part dimensions, wall thickness, mold condition, and molding parameters must also be considered.

*Re-machine gate diameter, if necessary, for larger shot weights.

Dimensions are in inches. Millimeters are in parentheses.

Chart 3

Resin Viscosity	Sprue Tips & Collar Gate Tip - Flats						
	Extra Stock Sprue Tips	Gate Insert Tip - Flats			Collar Gate Tip - Flats		
			0.020"	0.040"	0.070"	0.020"	0.040"
LOW	500	90	190	350	90	190	350
MEDIUM	300	70	150	250	70	150	250
HIGH	100	50	100	150	50	100	150

Consult Tutco Hot Runner Dept. when changing Max. shot weight.

DIRECT FEED APPLICATIONS

Precision LV® Technical Specifications

DIRECT FEED APPLICATIONS

375 LV

All specifications are subject to change without notification.

Head Options

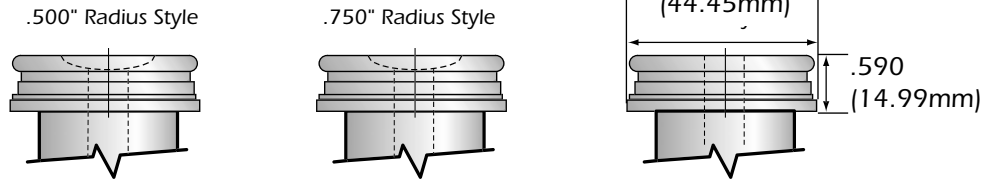

Gating Options / Bushing Dimensions

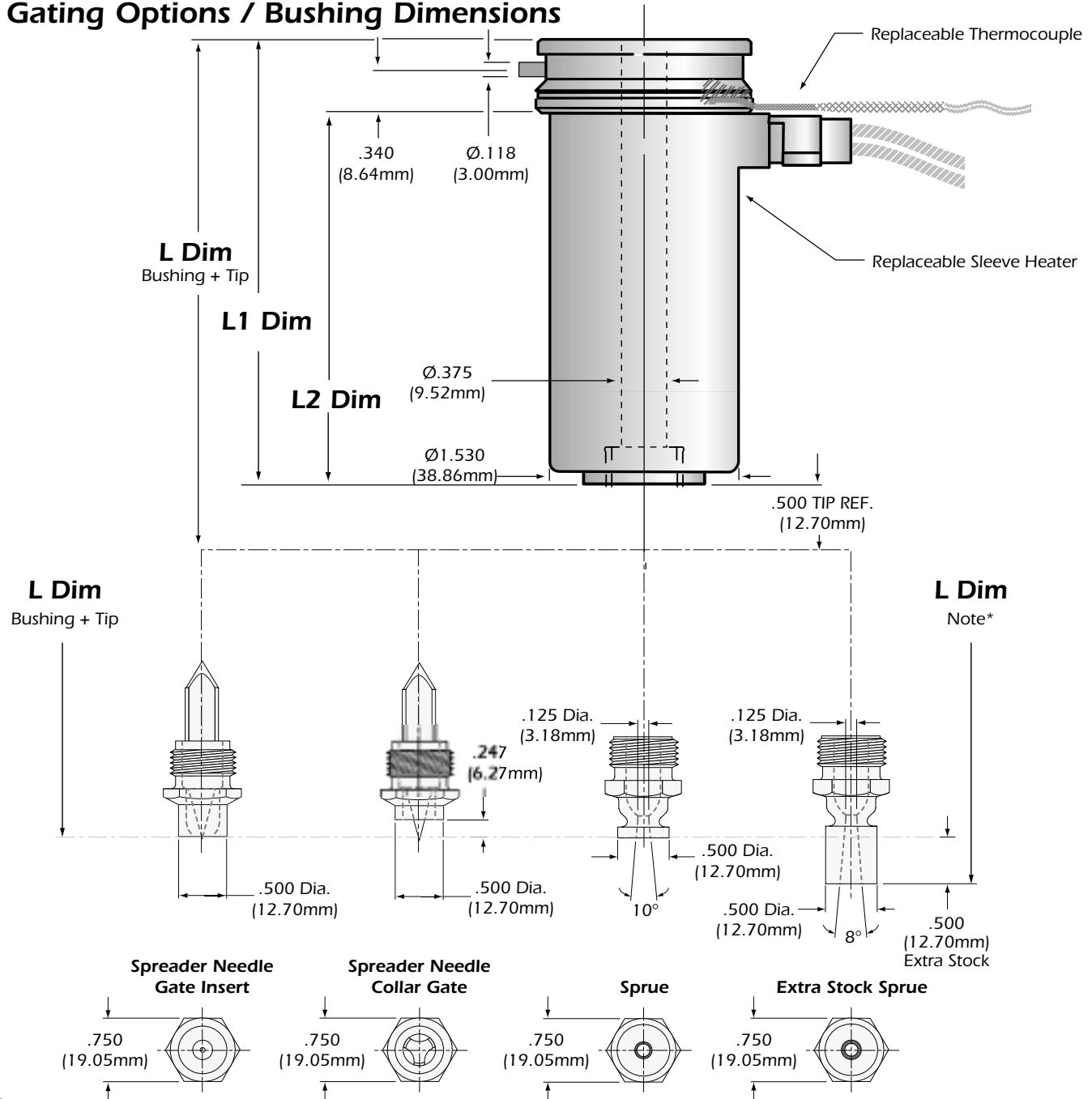

6

Precision LV® Technical Specifications

375 LV Ordering Charts

Chart A

Part Number	L Dim.		L Dim.		Body		Heater		L1 Dim.		L2 Dim.		T/C	Watts
	Gl, CG, Sprue		Extra Stock Sprue											
SV370000	2.625	(66.68)	3.125	(79.38)	MB370000	DS370000	2.125	(53.98)	1.535	(38.99)	MT020087	460		
SV370003	3.125	(79.38)	3.625	(92.08)	MB370003	DS370001	2.625	(66.68)	2.035	(51.69)	MT020088	460		
SV370006	3.625	(92.08)	4.125	(104.78)	MB370006	DS370002	3.125	(79.38)	2.535	(64.39)	MT020089	610		
SV370009	4.125	(104.78)	4.625	(117.48)	MB370009	DS370003	3.625	(92.08)	3.035	(77.09)	MT020090	610		
SV370012	4.625	(117.48)	5.125	(130.18)	MB370012	DS370004	4.125	(104.78)	3.535	(89.79)	MT020091	610		
SV370015	5.125	(130.18)	5.625	(142.88)	MB370015	DS370005	4.625	(117.48)	4.035	(102.49)	MT020092	690		
SV370018	6.125	(155.58)	6.625	(168.28)	MB370018	DS370006	5.625	(142.88)	5.035	(127.89)	MT020093	690		
SV370021	7.125	(180.98)	7.625	(193.68)	MB370021	DS370007	6.625	(168.28)	6.035	(153.29)	MT020094	765		
SV370024	8.125	(206.38)	8.625	(219.08)	MB370024	DS370008	7.625	(193.68)	7.035	(178.69)	MT020095	890		
SV370027	9.125	(231.78)	9.625	(244.48)	MB370027	DS370009	8.625	(219.08)	8.035	(204.09)	MT020096	1020		
SV370030	10.125	(257.18)	10.625	(269.88)	MB370030	DS370010	9.625	(244.48)	9.035	(229.49)	MT020097	1145		
SV370033	11.125	(282.58)	11.625	(295.28)	MB370033	DS370011	10.625	(269.88)	10.035	(254.89)	MT020098	1270		
SV370036	12.125	(307.98)	12.625	(320.68)	MB370036	DS370012	11.625	(295.28)	11.035	(280.29)	MT020099	1395		
SV370039	13.125	(333.38)	13.625	(346.08)	MB370039	DS370013	12.625	(320.68)	12.035	(305.69)	MT020100	1520		
SV370042	14.125	(358.78)	14.625	(371.48)	MB370042	DS370014	13.625	(346.08)	13.035	(331.09)	MT020101	1650		
SV370045	15.125	(384.18)	15.625	(396.88)	MB370045	DS370015	14.035	(371.48)	14.035	(356.49)	MT020102	1775		

SV370001	2.625	(66.68)	3.125	(79.38)	MB370001	DS370000	2.125	(53.98)	1.535	(38.99)	MT020087	460
SV370004	3.125	(79.38)	3.625	(92.08)	MB370004	DS370001	2.625	(66.68)	2.035	(51.69)	MT020088	460
SV370007	3.625	(92.08)	4.125	(104.78)	MB370007	DS370002	3.125	(79.38)	2.535	(64.39)	MT020089	610
SV370010	4.125	(104.78)	4.625	(117.48)	MB370010	DS370003	3.625	(92.08)	3.035	(77.09)	MT020090	610
SV370013	4.625	(117.48)	5.125	(130.18)	MB370013	DS370004	4.125	(104.78)	3.535	(89.79)	MT020091	610
SV370016	5.125	(130.18)	5.625	(142.88)	MB370016	DS370005	4.625	(117.48)	4.035	(102.49)	MT020092	690
SV370019	6.125	(155.58)	6.625	(168.28)	MB370019	DS370006	5.625	(142.88)	5.035	(127.89)	MT020093	690
SV370022	7.125	(180.98)	7.625	(193.68)	MB370022	DS370007	6.625	(168.28)	6.035	(153.29)	MT020094	765
SV370025	8.125	(206.38)	8.625	(219.08)	MB370025	DS370008	7.625	(193.68)	7.035	(178.69)	MT020095	890
SV370028	9.125	(231.78)	9.625	(244.48)	MB370028	DS370009	8.625	(219.08)	8.035	(204.09)	MT020096	1020
SV370031	10.125	(257.18)	10.625	(269.88)	MB370031	DS370010	9.625	(244.48)	9.035	(229.49)	MT020097	1145
SV370034	11.125	(282.58)	11.625	(295.28)	MB370034	DS370011	10.625	(269.88)	10.035	(254.89)	MT020098	1270
SV370037	12.125	(307.98)	12.625	(320.68)	MB370037	DS370012	11.625	(295.28)	11.035	(280.29)	MT020099	1395
SV370040	13.125	(333.38)	13.625	(346.08)	MB370040	DS370013	12.625	(320.68)	12.035	(305.69)	MT020100	1520
SV370043	14.125	(358.78)	14.625	(371.48)	MB370043	DS370014	13.625	(346.08)	13.035	(331.09)	MT020101	1650
SV370046	15.125	(384.18)	15.625	(396.88)	MB370046	DS370015	14.035	(371.48)	14.035	(356.49)	MT020102	1775

Part Number	L Dim.		L Dim.		Body		Heater		L1 Dim.		L2 Dim.		T/C	Watts
	Gl, CG, Sprue		Extra Stock Sprue											
SV370002	2.625	(66.68)	3.125	(79.38)	MB370002	DS370000	2.125	(53.98)	1.535	(38.99)	MT020087	460		
SV370005	3.125	(79.38)	3.625	(92.08)	MB370005	DS370001	2.625	(66.68)	2.035	(51.69)	MT020088	460		
SV370008	3.625	(92.08)	4.125	(104.78)	MB370008	DS370002	3.125	(79.38)	2.535	(64.39)	MT020089	610		
SV370011	4.125	(104.78)	4.625	(117.48)	MB370011	DS370003	3.625	(92.08)	3.035	(77.09)	MT020090	610		
SV370014	4.625	(117.48)	5.125	(130.18)	MB370014	DS370004	4.125	(104.78)	3.535	(89.79)	MT020091	610		
SV370017	5.125	(130.18)	5.625	(142.88)	MB370017	DS370005	4.625	(117.48)	4.035	(102.49)	MT020092	690		
SV370020	6.125	(155.58)	6.625	(168.28)	MB370020	DS370006	5.625	(142.88)	5.035	(127.89)	MT020093	690		
SV370023	7.125	(180.98)	7.625	(193.68)	MB370023	DS370007	6.625	(168.28)	6.035	(153.29)	MT020094	765		
SV370026	8.125	(206.38)	8.625	(219.08)	MB370026	DS370008	7.625	(193.68)	7.035	(178.69)	MT020095	890		
SV370029	9.125	(231.78)	9.625	(244.48)	MB370029	DS370009	8.625	(219.08)	8.035	(204.09)	MT020096	1020		
SV370032	10.125	(257.18)	10.625	(269.88)	MB370032	DS370010	9.625	(244.48)	9.035	(229.49)	MT020097	1145		
SV370035	11.125	(282.58)	11.625	(295.28)	MB370035	DS370011	10.625	(269.88)	10.035	(254.89)	MT020098	1270		
SV370038	12.125	(307.98)	12.625	(320.68)	MB370038	DS370012	11.625	(295.28)	11.035	(280.29)	MT020099	1395		
SV370041	13.125	(333.38)	13.625	(346.08)	MB370041	DS370013	12.625	(320.68)	12.035	(305.69)	MT020100	1520		
SV370044	14.125	(358.78)	14.625	(371.48)	MB370044	DS370014	13.625	(346.08)	13.035	(331.09)	MT020101	1650		
SV370047	15.125	(384.18)	15.625	(396.88)	MB370047	DS370015	14.625	(371.48)	14.035	(356.49)	MT020102	1775		

Dimensions are in inches. Millimeters are in parentheses.

* Precision 375 Adapter from Elite 375 MA010048

* Retaining Ring 100103

Tip Ordering Numbers

Chart B

Gate Style	Spreader Needle Assembly Part Numbers			
	Tip Alloy	0.065" Flat	0.080" Flat	0.100" Flat
Gate Insert	Standard	TP370410	TP370411	TP370412
	Wear Resistant	TP370413	TP370414	TP370415

Gate Style	Spreader Needle Assembly Part Numbers			
	Tip Alloy	0.065" Flat	0.080" Flat	0.100" Flat
Collar Gate	Standard	TP370416	TP370417	TP370418
	Wear Resistant	TP370419	TP370420	TP370421

Chart C

Gate Style	Tip Alloy	Part Number
Sprue	Standard	TP370110
	Wear Resistant	TP370111

Gate Style	Tip Alloy	Part Number
Extra Stock	Standard	TP370210
	Wear Resistant	TP370211

All specifications are subject to change without notification.

Hot Runner Systems by Tutco, 500 Gould Drive, Cookeville, TN 38506
Tel (931) 432-4141 • Fax (931) 432-4140 • www.tutco.com

TUTCO
HEATING SOLUTIONS GROUP

DIRECT FEED APPLICATIONS

Precision LV® Technical Specifications

DIRECT FEED APPLICATIONS

375 LV Bore & Gate Dimensions

All specifications are subject to change without notification.

Tol. "a" Chart

in:	+ 0.001
	- 0
mm:	+ 0.03
	- 0

Tol. "b" Chart

in:	+ 0.0003m
	- 0.0003m
mm:	+ 0.0008m
	- 0.0008m

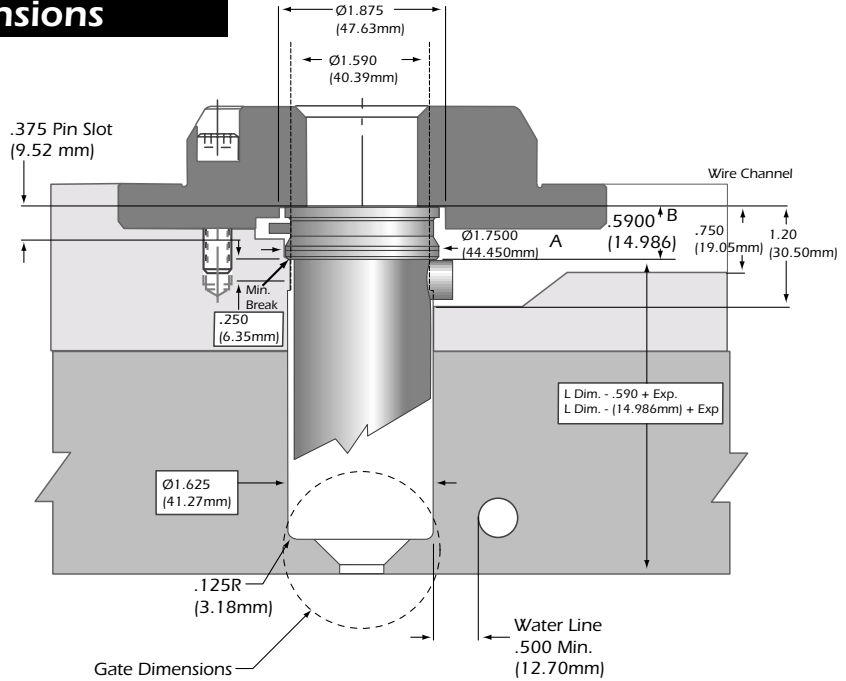

Thermal Expansion (Exp.) Formulas

$$\text{Exp. in} = (L \text{ in.} - .5900) \times 6.88 \times 10^{-6} \times (\text{Processing Temp.} - 70^\circ\text{F})$$

$$\text{Exp. mm} = (L \text{ mm.} - 14.99) \times 12.4 \times 10^{-6} \times (\text{Processing Temp.} - 21^\circ\text{C})$$

$$\text{Ref: } 10^{-6} = 0.000001$$

Dimensions are in inches. Millimeters are in parentheses.

Collar Gate

Non-Recessed Gate*

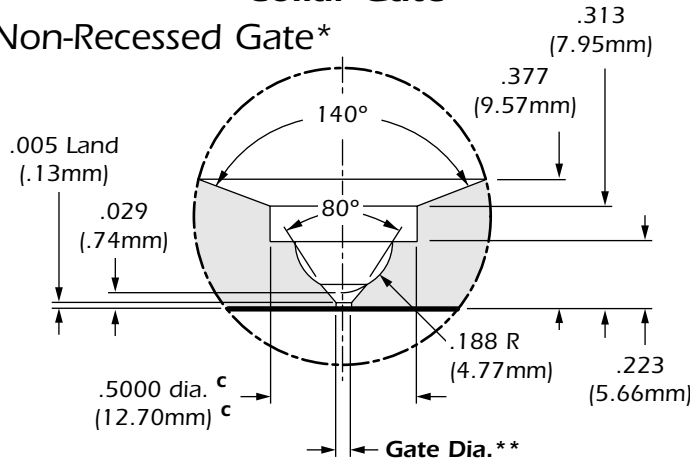

Gate Insert & Sprue Gate

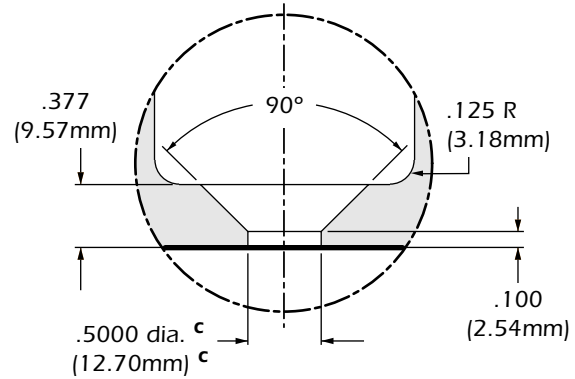

Recessed Gate*

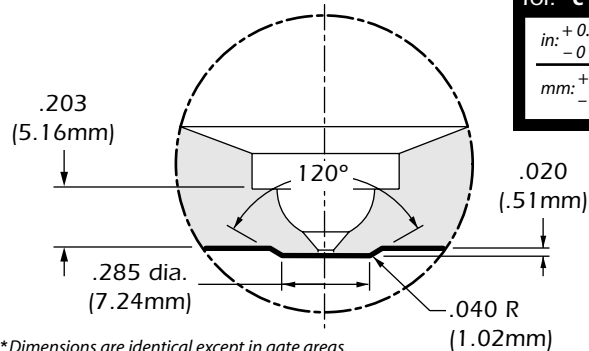

Tol. "c" Chart

in:	+ 0.0005
	- 0
mm:	+ 0.01
	- 0

Extra Stock Sprue Gate

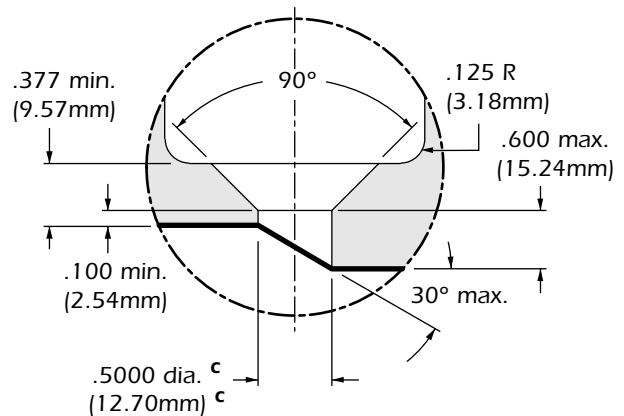

8

*Dimensions are identical except in gate areas.
**See Chart 2, page 9 for gate diameters.

Precision LV® Technical Specifications

375 LV Engineering Charts

Chart 1

Tip Alloy Reference: STD = Standard, WR = Wear Resistant

All specifications are subject to change without notification.

Tip Style	Part No.	Alloy	Commodity Resin	Engineering Resin	Glass-Filled Resin
Sprue	TP370110	STD	●	●	
	TP370111	WR	●	●	●
Extra Stock Sprue	TP370210	STD	●	●	
	TP370211	WR	●	●	●
Gate Insert 0.065" Flat	TP370410	STD	●	●	
	TP370413	WR	●	●	●
Gate Insert 0.080" Flat	TP370411	STD	●	●	
	TP370414	WR	●	●	●
Gate Insert 0.100" Flat	TP370412	STD	●	●	
	TP370415	WR	●	●	●
Collar Gate 0.065" Flat	TP370416	STD	●	●	
	TP370419	WR	●	●	●
Collar Gate 0.080" Flat	TP370417	STD	●	●	
	TP370420	WR	●	●	●
Collar Gate 0.100" Flat	TP370418	STD	●	●	
	TP370421	WR	●	●	●

Reference: ● = Recommended

Chart 2

Spreader Needle tips	Resin Viscosity		
	High	Medium	Low
Gate Insert 0.065" Flat	.127" to .159"	.105" to .127"	.085" to .105"
Collar Gate 0.065" Flat	(3.20mm to 4.00mm)	(2.70mm to 3.20mm)	(2.20mm to 2.70mm)
Gate Insert 0.080" Flat	.142" to .174"	.120" to .142"	.100" to .120"
Collar Gate 0.080" Flat	(3.60mm to 4.40mm)	(3.00mm to 3.60mm)	(2.50mm to 3.00mm)
Gate Insert 0.100" Flat	.162" to .194"	.140" to .162"	.120" to .140"
Collar Gate 0.100" Flat	(4.10mm to 4.90mm)	(3.60mm to 4.10mm)	(3.00mm to 3.60mm)
Sprue tips	High	Medium	Low
All Sprue	.125" to .250"*	.125" to .250"*	.125" to .250"*
Part Numbers	(3.20mm to 6.40mm)	(3.20mm to 6.40mm)	(3.20mm to 6.40mm)

Reference: High Viscosity = Melt Flow (0.02 – 6); Medium Viscosity = Melt Flow (7 – 16); Low Viscosity = Melt Flow (16 – up). The values expressed in grams are for reference purposes only. Part dimensions, wall thickness, mold condition, and molding parameters must also be considered.

*Re-machine gate diameter, if necessary, for larger shot weights.

Dimensions are in inches. Millimeters are in parentheses.

Chart 3

Resin Viscosity	Sprue Tips & Gate Insert Tip - Flats						
	Extra Stock Sprue Tips	Gate Insert Tip - Flats			Collar Gate Tip - Flats		
		0.065"	0.080"	0.100"	0.065"	0.080"	0.100"
LOW	2000	350	400	500	350	400	500
MEDIUM	1000	300	350	450	300	350	450
HIGH	500	250	300	400	250	300	400

Consult Tutco Hot Runner Dept. when changing Max. shot weight.

DIRECT FEED APPLICATIONS

Precision LV® Technical Specifications

DIRECT FEED APPLICATIONS

625 LV

All specifications are subject to change without notification.

Head Options

.500" Radius Style

.750" Radius Style

Plain Style

2.30

(58.420mm)

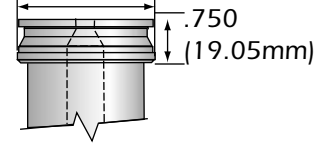
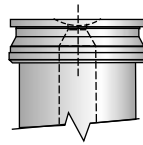
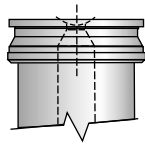

Gating Options / Bushing Dimensions

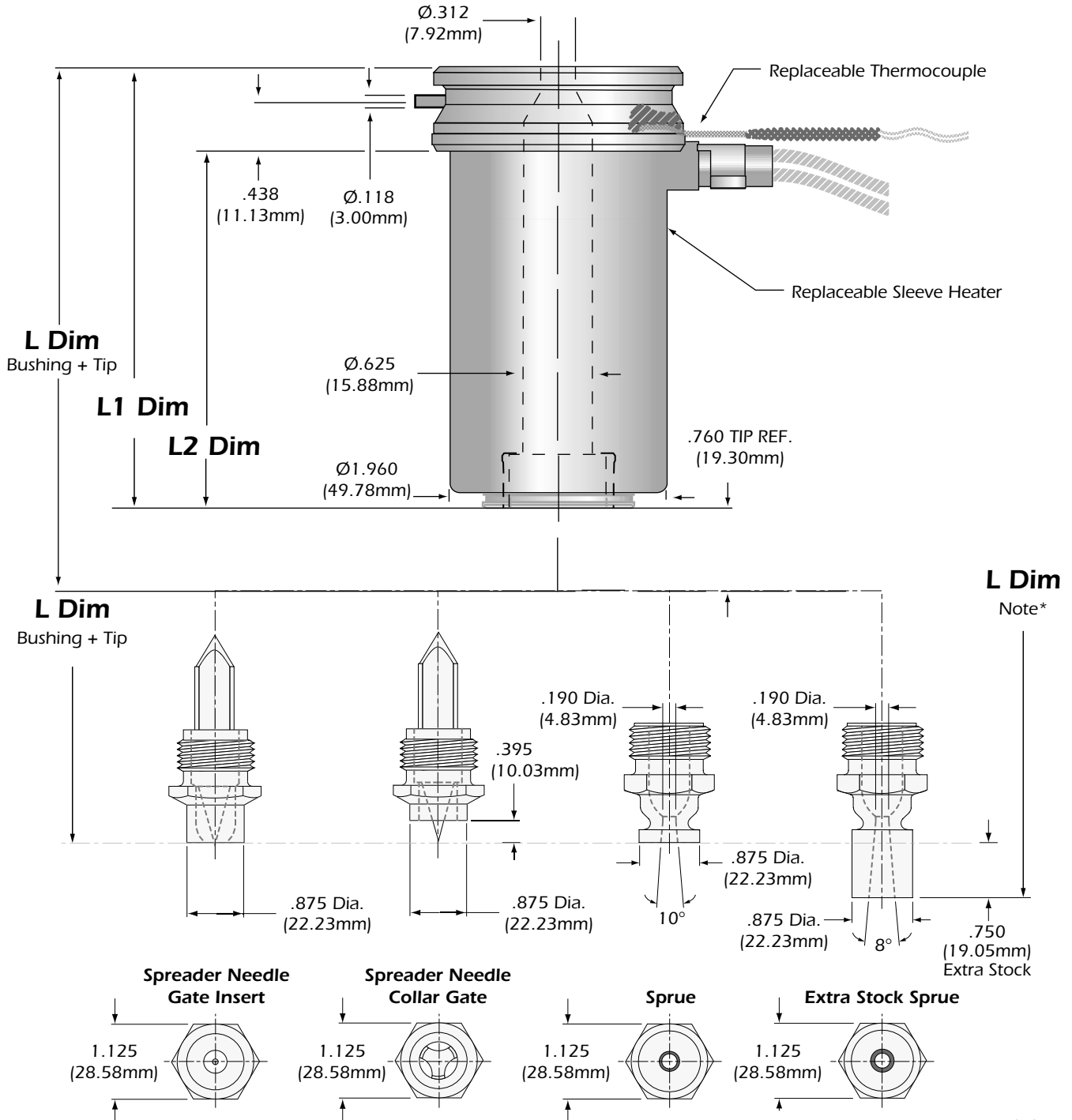

10

Dimensions are in inches. Millimeters are in parentheses.

*Note: Dimensions include extra stock.
**Note: For additional gate dimensions see page 12.

Precision LV® Technical Specifications

625 LV Ordering Charts

Chart A

.500

Part Number	L Dim.		L Dim.		Body Heater		L1 Dim.		L2 Dim.		T/C	Watts
	Gl, CG, Sprue	()	Extra Stock Sprue	()								
SV620001	3.750	(95.25)	4.500	(114.30)	MB620001	DS260000	2.990	(75.95)	2.240	(56.90)	MT020080	750
SV620005	4.750	(120.65)	5.500	(139.70)	MB620005	DS260001	3.990	(101.35)	3.240	(82.30)	MT020081	750
SV620009	5.750	(146.05)	6.500	(165.10)	MB620009	DS260002	4.990	(126.75)	4.240	(107.70)	MT020069	755
SV620013	6.750	(171.45)	7.500	(190.50)	MB620013	DS260003	5.990	(152.15)	5.240	(133.10)	MT020070	930
SV620017	7.750	(196.85)	8.500	(215.90)	MB620017	DS260004	6.990	(177.55)	6.240	(158.50)	MT020071	1100
SV620021	8.750	(222.25)	9.500	(241.30)	MB620021	DS260005	7.990	(202.95)	7.240	(183.90)	MT020072	1275
SV620025	9.750	(247.65)	10.500	(266.70)	MB620025	DS260006	8.990	(228.35)	8.240	(209.30)	MT020073	1450
SV620029	10.750	(273.05)	11.500	(292.10)	MB620029	DS260007	9.990	(253.75)	9.240	(234.70)	MT020074	1625
SV620033	11.750	(298.45)	12.500	(317.50)	MB620033	DS260008	10.990	(279.15)	10.240	(260.10)	MT020075	1795
SV620037	12.750	(323.85)	13.500	(342.90)	MB620037	DS260009	11.990	(304.55)	11.240	(285.50)	MT020082	1970

.750

SV620002	3.750	(95.25)	4.500	(114.30)	MB620002	DS260000	2.990	(75.95)	2.240	(56.90)	MT020080	750
SV620006	4.750	(120.65)	5.500	(139.70)	MB620006	DS260001	3.990	(101.35)	3.240	(82.30)	MT020081	750
SV620010	5.750	(146.05)	6.500	(165.10)	MB620010	DS260002	4.990	(126.75)	4.240	(107.70)	MT020069	755
SV620014	6.750	(171.45)	7.500	(190.50)	MB620014	DS260003	5.990	(152.15)	5.240	(133.10)	MT020070	930
SV620018	7.750	(196.85)	8.500	(215.90)	MB620018	DS260004	6.990	(177.55)	6.240	(158.50)	MT020071	1100
SV620022	8.750	(222.25)	9.500	(241.30)	MB620022	DS260005	7.990	(202.95)	7.240	(183.90)	MT020072	1275
SV620026	9.750	(247.65)	10.500	(266.70)	MB620026	DS260006	8.990	(228.35)	8.240	(209.30)	MT020073	1450
SV620030	10.750	(273.05)	11.500	(292.10)	MB620030	DS260007	9.990	(253.75)	9.240	(234.70)	MT020074	1625
SV620034	11.750	(298.45)	12.500	(317.50)	MB620034	DS260008	10.990	(279.15)	10.240	(260.10)	MT020075	1795
SV620038	12.750	(323.85)	13.500	(342.90)	MB620038	DS260009	11.990	(304.55)	11.240	(285.50)	MT020082	1970

Plain

Part Number	L Dim.		L Dim.		Body Heat		L1 Dim.		L2 Dim.		T/C	Watts
	Gl, CG, Sprue	()	Extra Stock Sprue	()								
SV620000	3.750	(95.25)	4.500	(114.30)	MB620000	DS260000	2.990	(75.95)	2.240	(56.90)	MT020080	750
SV620004	4.750	(120.65)	5.500	(139.70)	MB620004	DS260001	3.990	(101.35)	3.240	(82.30)	MT020081	750
SV620008	5.750	(146.05)	6.500	(165.10)	MB620008	DS260002	4.990	(126.75)	4.240	(107.70)	MT020069	755
SV620012	6.750	(171.45)	7.500	(190.50)	MB620012	DS260003	5.990	(152.15)	5.240	(133.10)	MT020070	930
SV620016	7.750	(196.85)	8.500	(215.90)	MB620016	DS260004	6.990	(177.55)	6.240	(158.50)	MT020071	1100
SV620020	8.750	(222.25)	9.500	(241.30)	MB620020	DS260005	7.990	(202.95)	7.240	(183.90)	MT020072	1275
SV620024	9.750	(247.65)	10.500	(266.70)	MB620024	DS260006	8.990	(228.35)	8.240	(209.30)	MT020073	1450
SV620028	10.750	(273.05)	11.500	(292.10)	MB620028	DS260007	9.990	(253.75)	9.240	(234.70)	MT020074	1625
SV620032	11.750	(298.45)	12.500	(317.50)	MB620032	DS260008	10.990	(279.15)	10.240	(260.10)	MT020075	1795
SV620036	12.750	(323.85)	13.500	(342.90)	MB620036	DS260009	11.990	(304.55)	11.240	(285.50)	MT020082	1970

Dimensions are in inches. Millimeters are in parentheses.

* Precision 625 Adapter from Elite LV 625 MA010049

* Retaining Ring 100105

Tip Ordering Numbers

Chart B



Gate Style	Tip Alloy	Spreader Needle Assembly Part Numbers		
	Tip Alloy	0.100" Flat	0.125" Flat	0.150" Flat
	Standard	TP620410	TP620411	TP620412
	Wear Resistant	TP620413	TP620414	TP620415
Gate Style	Tip Alloy	Spreader Needle Assembly Part Numbers		
	Tip Alloy	0.100" Flat	0.125" Flat	0.150" Flat
	Standard	TP620416	TP620417	TP620418
	Wear Resistant	TP620419	TP620420	TP620421

Chart C

Gate Style	Tip Alloy	Part Number
	Standard	TP620110
	Wear Resistant	TP620111
Gate Style	Tip Alloy	Part Number
	Standard	TP620210
	Wear Resistant	TP620211

All specifications are subject to change without notification.

Precision LV® Technical Specifications

DIRECT FEED APPLICATIONS

625 PLUS Bore & Gate Dimensions

All specifications are subject to change without notification.

Tol. "a" Chart

in:	+ 0.001
	- 0
mm:	+ 0.02
	- 0

Tol. "b" Chart

in:	+ 0.0003m
	- 0.0003m
mm:	+ 0.0008m
	- 0.0008m

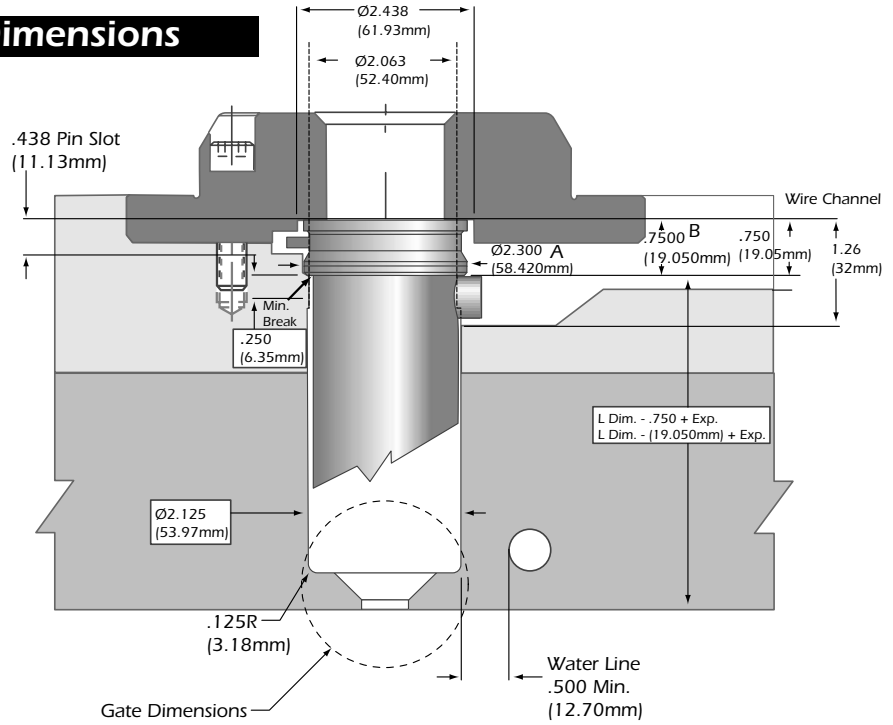

Thermal Expansion (Exp.) Formulas

$$\text{Exp. in} = (L \text{ in.} - .7500) \times 6.88 \times 10^{-6} \times (\text{Processing Temp.} - 70^\circ\text{F})$$

$$\text{Exp. mm} = (L \text{ mm.} - 19.05) \times 12.4 \times 10^{-6} \times (\text{Processing Temp.} - 21^\circ\text{C})$$

$$\text{Ref: } 10^{-6} = 0.000001$$

Dimensions are in inches. Millimeters are in parentheses.

Collar Gate

Non-Recessed Gate*

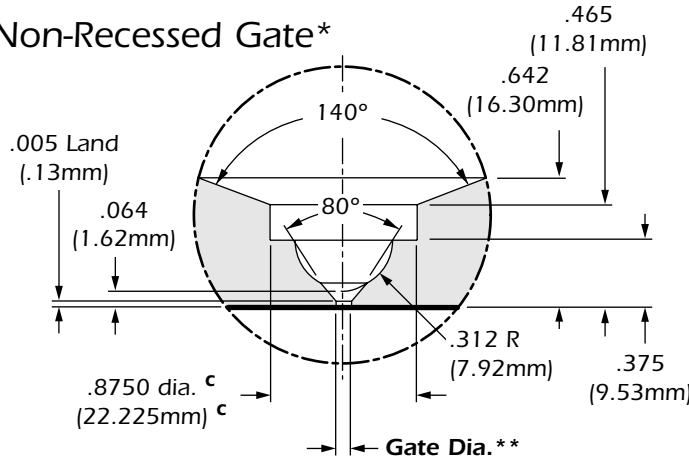

Gate Insert & Sprue Gate

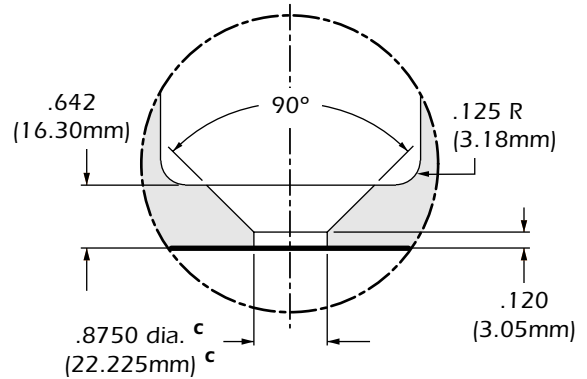

Recessed Gate*

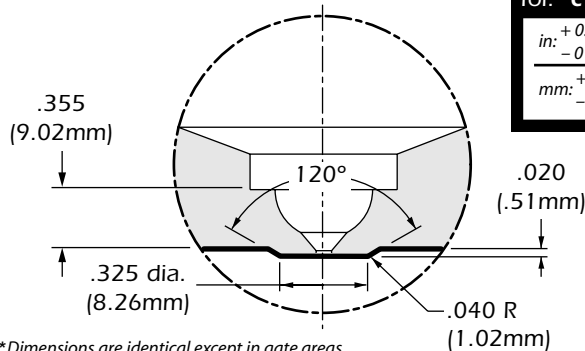

Tol. "c" Chart

in:	+ 0.0005
	- 0
mm:	+ 0.01
	- 0

Extra Stock Sprue Gate

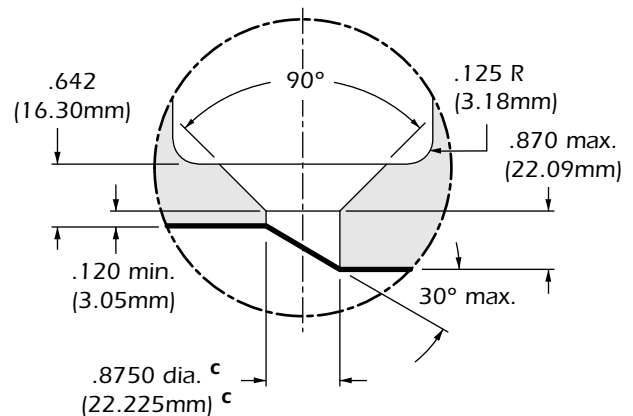

12

*Dimensions are identical except in gate areas.
**See Chart 2, page 9 for gate diameters.

Precision LV® Technical Specifications

625 PLUS Engineering Charts

Chart 1

Tip Alloy Reference: STD = Standard, WR = Wear Resistant

All specifications are subject to change without notification.

625 PLUS Resin Compatibility Chart						
Tip Style	Part No.	Alloy	Commodity Resin	Engineering Resin	Glass-Filled Resin	
Sprue	TP620110	STD	●	●		
	TP620111	WR	●	●	●	
Extra Stock Sprue	TP620210	STD	●	●		
	TP620211	WR	●	●	●	
Gate Insert 0.100" Flat	TP620410	STD	●	●		
	TP620413	WR	●	●	●	
Gate Insert 0.125" Flat	TP620411	STD	●	●		
	TP620414	WR	●	●	●	
Gate Insert 0.150" Flat	TP620412	STD	●	●		
	TP620415	WR	●	●	●	
Collar Gate 0.100" Flat	TP620416	STD	●	●		
	TP620419	WR	●	●	●	
Collar Gate 0.125" Flat	TP620417	STD	●	●		
	TP620420	WR	●	●	●	
Collar Gate 0.150" Flat	TP620418	STD	●	●		
	TP620421	WR	●	●	●	

Reference: ● = Recommended

Chart 2

625 PLUS Gate Diameters			
Spreader Needle tips	Resin Viscosity		
	High	Medium	Low
Gate Insert 0.100" Flat	.162" to .194"	.140" to .162"	.120" to .140"
Collar Gate 0.100" Flat	(4.10mm to 4.90mm)	(3.60mm to 4.10mm)	(3.00mm to 3.60mm)
Gate Insert 0.125" Flat	.187" to .219"	.165" to .187"	.145" to .165"
Collar Gate 0.125" Flat	(4.70mm to 5.60mm)	(4.20mm to 4.70mm)	(3.70mm to 4.20mm)
Gate Insert 0.150" Flat	.212" to .244"	.190" to .212"	.170" to .190"
Collar Gate 0.150" Flat	(5.40mm to 6.20mm)	(4.80mm to 5.40mm)	(4.30mm to 4.80mm)
Sprue tips	High	Medium	Low
All Sprue	.187" to .312"*	.187" to .312"*	.187" to .312"*
Part Numbers	(4.90mm to 7.90mm)	(4.70mm to 7.90mm)	(4.70mm to 7.90mm)

Reference: High Viscosity = Melt Flow (0.02 – 6); Medium Viscosity = Melt Flow (7 – 16); Low Viscosity = Melt Flow (16 – up). The values expressed in grams are for reference purposes only. Part dimensions, wall thickness, mold condition, and molding parameters must also be considered.

*Re-machine gate diameter, if necessary, for larger shot weights.

Dimensions are in inches. Millimeters are in parentheses.

Chart 3

625 PLUS Maximum Shot Weight in Grams							
Resin Viscosity	Sprue Tips & Gate Insert Tip - Flats						
	Extra Stock Sprue Tips	Gate Insert Tip - Flats			Collar Gate Tip - Flats		
		0.100"	0.125"	0.150"	0.100"	0.125"	0.150"
LOW	4000	600	900	1900	600	900	1900
MEDIUM	2000	500	800	1400	500	800	1400
HIGH	1000	400	700	1000	400	700	1000

Consult Tutco Hot Runner Dept. when changing Max. shot weight.

Precision LV® Technical Specifications

Operating/Service Instructions

All specifications are subject to change without notification.

Operating & Servicing Instructions

The Precision LV Nozzle bodies are identical in design, but differ in length, diameter and head style. All Precision LV nozzles feature: unique sleeve heater design; Type "J" thermocouple; 36" teflon wrap - 600 Volt leads; right angle lead exit; and 6" fiberglass sleeving.

Start-up/Operating Procedures

If the temperature controller does not utilize "soft start" technology, set the controller to 200°F (93.3°C) in automatic or 10% in manual. Allow bushing to "soak" for 15 minutes before increasing to processing temperature. This step will allow the unit to dissipate any moisture and prolong heater life.

Tip Removal/Installation

Removal

- 1) Secure the bushing firmly using a "V" block on the diameter or a vise against the flats machined on the head of the bushing
- 2) Use standard 9/16", 3/4", or 1-1/8" socket and remove tip by turning counter-clockwise.

Installation

- 1) Place bushing in "V" block and secure it firmly at the bushing head.
- 2) Apply anti-seize sparingly onto male threads of tip.
Note: Excess anti-seize may contaminate the resin being processed.
- 3) Use standard 9/16", 3/4", or 1-1/8" socket and install tip by turning clockwise.
- 4) **Torque to 30 ft./lbs. (41 Newton-Meters)**

Power Requirements

- 240 Volts AC – 15 amp fuse
- Grounding – Tutco brushings utilize the direct contact of the bushing, mold plates, and machine platens to establish a path for grounding.

WARNING

There must be a ground  present between the Mold "Hot Half" and the temperature control system or damage may occur to the bushing, thermocouple and/or temperature control system.