

**LC6375D COMBINATION LOUVER
DRAINABLE BLADE
ROLL FORMED STEEL**

STANDARD CONSTRUCTION

FRAME

6" (152) deep, 16 gage (1.5) galvanized steel. Downspouts provided.

BLADES

Front stationary blades – 18 (1.2) gage galvanized steel. Drainable blades are positioned at 37½° angle and spaced approximately 4½" (114) centers.

Rear adjustable blades – 16 (1.5) gage galvanized steel, positioned at 45° angle.

SEALS

Neoprene blade seals
Aluminum jamb seals

BEARINGS

Stainless steel sleeve pressed into frame.

AXLES

½" (13) plated steel hex.

LINKAGE

Concealed.

OPERATOR

Locking louver quadrant.

FINISH

Mill.

MINIMUM SIZE

12"w x 12"h (305 x 305).

MAXIMUM FACTORY ASSEMBLY SIZE

Sections shall not exceed 120" x 90" (3048 x 2286) and shall not exceed 75 sq ft unless otherwise specified. Maximum width shall not exceed 48" (1219) with seals and 60" (1524) without seals.

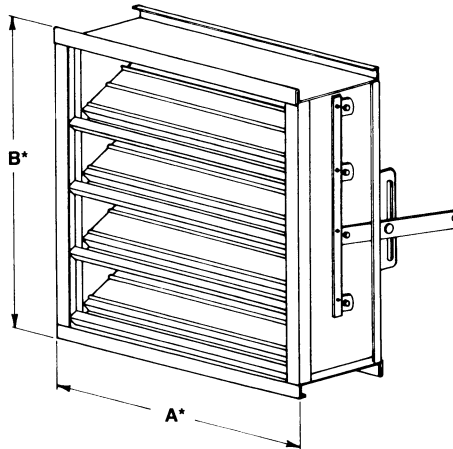

FEATURES

- Published performance ratings based on testing in accordance with AMCA Publication 511.
- Tight shut off in air intake and exhaust applications.
- Front stationary blades and adjustable rear blades in a 6" (152) frame.
- Drain gutter in each front stationary blade and downspouts in jamba and mullions for minimum water cascade.
- Architecturally styled hidden mullions allowing continuous line appearance up to 120".
- Blade and jamb seals provide tight closure

VARIATIONS

Variations to the basic design of this louver are available at additional cost. They include:

- A variety of bird and insect screens.
- Blade edge and jamb seals
- Selection of finishes: baked enamel (modified fluoropolymer), epoxy, PVDF, Fluoridize and prime coat.
- A selection of manual, electric, and pneumatic actuators.

Consult Ruskin for other special requirements.

FRAME CONSTRUCTION

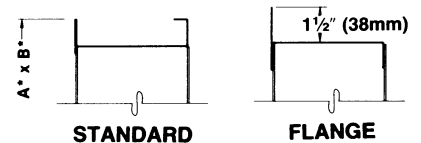

Dimensions in parenthesis () indicate millimeters.

*Units furnished ¼" (6) smaller than given opening dimensions.

FREE AREA GUIDE

Free Area Guide shows free area in ft² and m² for various sizes of LC6375D.
Width – Inches and Meters

Height – Inches and Meters	12	18	24	30	36	42	48	54	60	66	72	78	84	90	96
	.30	.46	.61	.76	.91	1.07	1.22	1.37	1.52	1.68	1.83	1.98	2.13	2.29	2.44
12	0.07	0.11	0.16	0.20	0.24	0.28	0.33	0.37	0.41	0.46	0.50	0.54	0.58	0.63	0.67
.30	.01	.01	.01	.02	.02	.03	.03	.03	.04	.04	.05	.05	.05	.06	.06
18	0.44	0.70	0.97	1.24	1.51	1.78	2.05	2.31	2.58	2.85	3.12	3.39	3.65	3.92	4.19
.46	.04	.07	.09	.12	.14	.17	.19	.21	.24	.26	.29	.31	.34	.36	.39
24	0.62	1.00	1.38	1.76	2.14	2.53	2.91	3.29	3.67	4.05	4.43	4.81	5.19	5.58	5.96
.6180	.06	.09	.13	.16	.20	.23	.27	.31	.34	.38	.41	.45	.48	.52	.55
30	0.80	1.30	1.79	2.29	2.78	3.28	3.77	4.27	4.76	5.26	5.75	6.25	6.74	7.24	7.73
.76	.07	.12	.17	.21	.26	.30	.35	.40	.44	.49	.53	.58	.63	.67	.72
36	1.17	1.89	2.61	3.33	4.05	4.77	5.49	6.21	6.93	7.65	8.37	9.09	9.81	10.53	11.25
.91	.11	.18	.24	.31	.38	.44	.51	.58	.64	.71	.78	.84	.91	.98	1.05
42	1.35	2.19	3.02	3.85	4.69	5.52	6.35	7.19	8.02	8.85	9.69	10.52	11.35	12.19	13.02
1.07	.13	.20	.28	.36	.44	.51	.59	.67	.75	.82	.90	.98	1.05	1.13	1.21
48	1.54	2.49	3.43	4.38	5.33	6.27	7.22	8.17	9.11	10.06	11.01	11.95	12.90	13.85	14.79
1.22	.14	.23	.32	.41	.49	.58	.67	.76	.85	.93	1.02	1.11	1.20	1.29	1.37
54	1.87	3.02	4.17	5.32	6.47	7.61	8.76	9.91	11.06	12.21	13.36	14.51	15.66	16.81	17.96
1.37	.17	.28	.39	.49	.60	.71	.81	.92	1.03	1.13	1.24	1.35	1.45	1.56	1.67
60	2.09	3.37	4.66	5.94	7.23	8.51	9.80	11.08	12.37	13.66	14.94	16.23	17.51	18.80	20.08
1.52	.19	.31	.43	.55	.67	.79	.91	1.03	1.15	1.27	1.39	1.51	1.63	1.75	1.87
66	2.27	3.67	5.07	6.47	7.87	9.27	10.67	12.07	13.46	14.86	16.26	17.66	19.06	20.46	21.86
1.68	.21	.34	.47	.60	.73	.86	.99	1.12	1.25	1.38	1.51	1.64	1.77	1.90	2.03
72	2.60	4.20	5.81	7.41	9.01	10.61	12.21	13.81	15.41	17.02	18.62	20.22	21.82	23.42	25.02
1.83	.24	.39	.54	.69	.84	.99	1.13	1.28	1.43	1.58	1.73	1.88	2.03	2.18	2.32
78	2.82	4.56	6.30	8.03	9.77	11.51	13.25	14.98	16.72	18.46	20.20	21.93	23.67	25.41	27.14
1.98	.26	.42	.59	.75	.91	1.07	1.23	1.39	1.55	1.71	1.88	2.04	2.20	2.36	2.52
84	3.01	4.86	6.71	8.56	10.41	12.26	14.11	15.96	17.81	19.66	21.51	23.37	25.22	27.07	28.92
2.13	.28	.45	.62	.80	.97	1.14	1.31	1.48	1.65	1.83	2.00	2.17	2.34	2.51	2.69
90	3.34	5.39	7.44	9.50	11.55	13.60	15.66	17.71	19.76	21.82	23.87	25.92	27.98	30.03	32.08
2.29	.31	.50	.69	.88	1.07	1.26	1.45	1.65	1.84	2.03	2.22	2.41	2.60	2.79	2.98
96	3.56	5.75	7.94	10.13	12.31	14.50	16.69	18.88	21.07	23.26	25.45	27.64	29.83	32.02	34.21
2.44	.33	.53	.74	.94	1.14	1.35	1.55	1.75	1.96	2.16	2.36	2.57	2.77	2.97	3.18



Ruskin Manufacturing Company certifies that the LC6375D Louvers shown herein are licensed to bear the AMCA Seal. The ratings shown are based on tests and procedures performed in accordance with AMCA Publication 511 and comply with the requirements of the AMCA Certified Ratings Program. The AMCA Certified Ratings Seal applies to air performance and water penetration ratings.

WATER PENETRATION

Test size 48" wide x 48" high (1219 x 1219)

Beginning point of water penetration at .01 oz./sq. ft. is 1046 fpm (319 m/min).

AMCA Standard 500 provides a reasonable basis for testing and rating louvers. Testing to AMCA 500 is performed under a certain set of laboratory conditions. This does not guarantee that other conditions will not occur in the actual environment where louvers must operate.

Designs should provide a reasonable safety factor for louver performance by selecting at some point below pressure drop or water penetration system requirements.

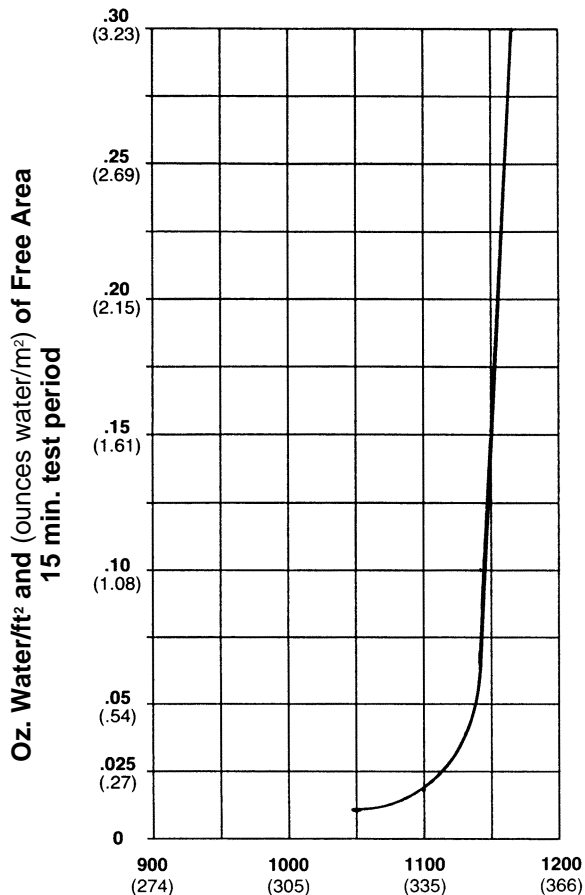

Free Area Velocity in feet and (meters) per minute
Standard air .075 lb/ft³

PRESSURE DROP

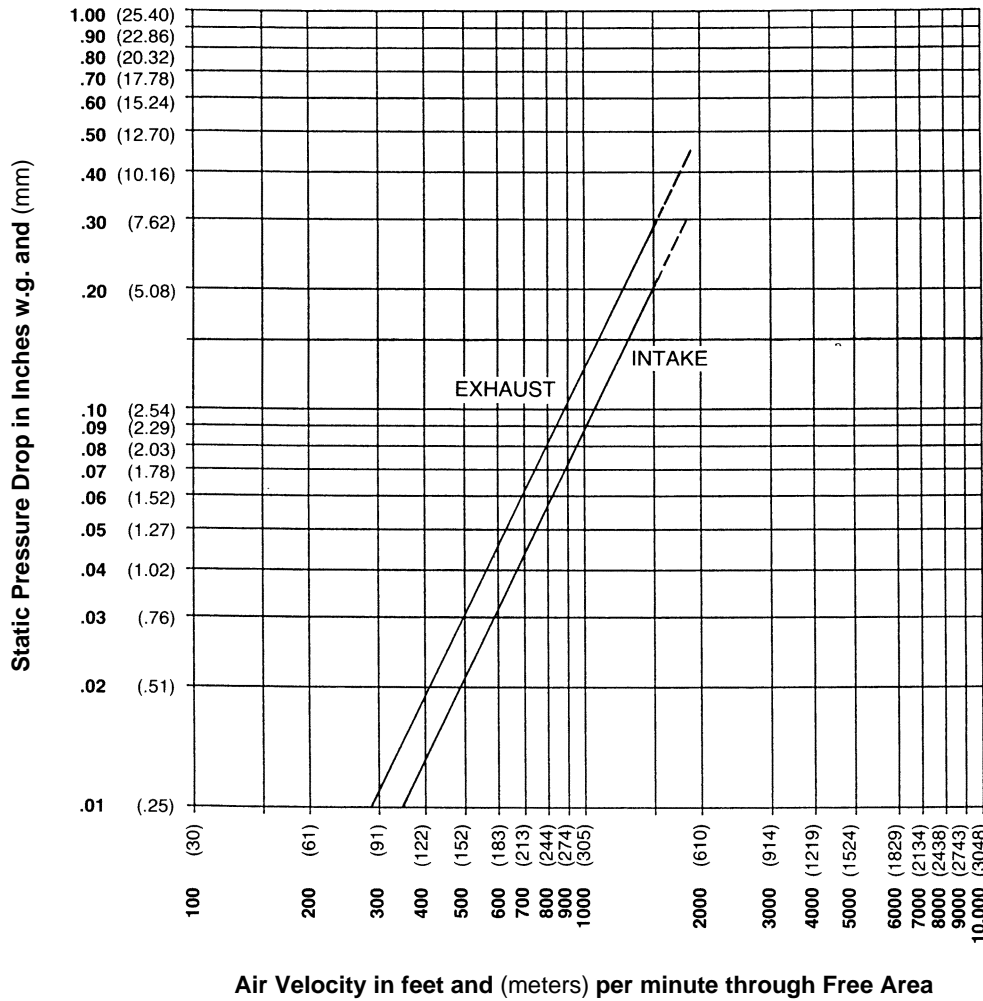

Ratings do not include the effect of a bird screen.

SUGGESTED SPECIFICATION

Furnish and install louvers as hereinafter specified where shown on plans or as described in schedules. Louvers shall be combination stationary adjustable drainable type with a drain gutter in each stationary blade and downspouts in jambs and mullions. Stationary blades and adjustable blades shall be contained within a single 6" (152) louver frame. Adjustable sections shall include low leakage blade and jamb seals. Louver components (heads, jambs, sills, blades, and mullions) shall be factory assembled by the louver manufacturer. Louver sizes too large for shipping shall be built up by the contractor from factory assembled louver sections to provide overall sizes required. Louver design shall incorporate structural supports required to withstand a wind load of 20 lbs. per sq. ft. (.96kPa) (equivalent of a 90 mph wind [145 KPH] - specifier may substitute any loading required).

Louvers shall be Ruskin Model LC6375D construction as follows:

Frame: 16 gage (1.6) galvanized steel.

Blades: Front stationary drainable blades are 18 gage (1.2) galvanized steel. Positioned at 37¹/₂° angle on approximately 4¹/₂" (114) centers.

Rear adjustable blades are 16 gage (1.6) galvanized steel. Positioned at 45° angle when fully open.

Each adjustable louver section shall include manual operating quadrant.

Finish: Select finish specification from Ruskin/Valspar Finishes Brochure.

