

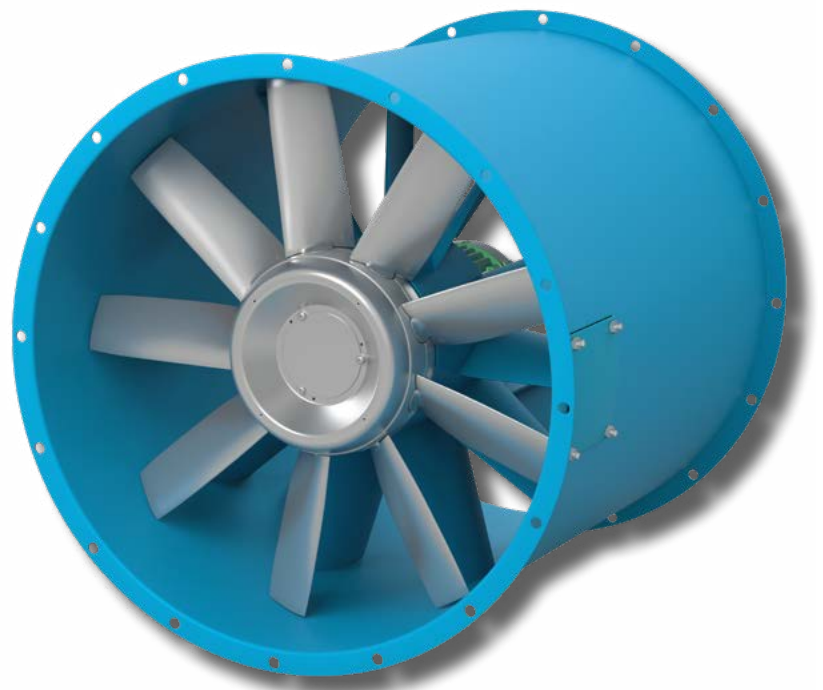

INDUSTRIAL PROCESS AND
COMMERCIAL VENTILATION SYSTEMS

AXIFAN[®] ADJUSTABLE BLADE VANE AXIAL FANS

Model TCVX



VANEAXIAL FANS

Overview

TCVX

Model TCVX,
Arrangement 9

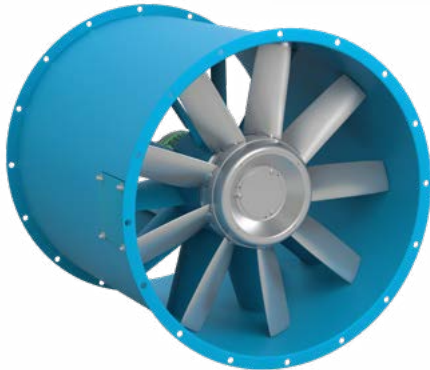

Model TCVX,
Arrangement 4

The TCVX AXIFAN® is a proven workhorse for industrial ventilation applications. The blade pitch of the impeller is factory set for optimal efficiency, reducing the lifetime energy cost of ownership. The patented hub design also allows for the blade pitch to be field adjusted when actual site conditions in the ventilation system do not match design parameters. Cast of high strength aluminum alloy, the TCVX AXIFAN® impeller provides efficiency and reliability for your air movement requirements.

Typical Applications Include

Gas Turbine Enclosure Exhaust, Generator Pressurization, Paint Spray Booth Exhaust, Paper and Pulp Process Exhaust, Mining Ventilation, Aerodynamic Wind Tunnels, Automotive Test Cells, General HVAC, Stairwell Pressurization

Configurations

Direct and Belt Driven – vertical & horizontal mount configurations

Impeller Type

Cast Aluminum

Optional Construction

Clamshell Design, Swingout Design, Spark Resistant Construction, Aluminum Housing, Hot Dip Galvanized Housing, 304SS Housing, 316SS Housing

Certifications

AMCA Sound/Air and FEG, UL 705 Listed for Electrical

Model Nomenclature

TCVX AXIFAN® model numbers are represented as follows.

36 D 5

Approximation of Hub-To-Tip Ratio
Where: 2 ≅ 37%, 3 ≅ 40%, 4 ≅ 43%, 5 ≅ 50%
6 ≅ 57%, 7 ≅ 66%, 8 ≅ 78%

Drive
B = Belt Driven (Arr. 9)
D = Direct Drive (Arr. 4)

Fan Diameter (inches)



Twin City Fan & Blower certifies that the models shown herein are licensed to bear the AMCA Seal for Sound and Air. The ratings shown are based on tests and procedures performed in accordance with AMCA Publication 211 and AMCA Publication 311 and comply with the AMCA Certified Ratings Program.

Refer to Catalog AX301 for sound power levels.



Model TCVX is available with the UL/cUL 705 listing for electrical, File No. E158680.



For complete product performance, drawings and available accessories, download our Fan Selector program at tcf.com.

Applications

TCVX

Ventilation

The TCVX AXIFAN® vaneaxial is a logical choice for any ventilation system, as either a supply or return fan. It can be ducted or provided with an inlet bell for open (or unducted) inlet installations. The ability to fine-tune the system performance through blade angle adjustment insures the user of a highly efficient, economical, versatile, quiet and long-running fan.

Industrial Process

The TCVX AXIFAN® is an ideal component for most industrial air systems. This unit is designed with a heavy-duty housing and large diameter shaft and bearings for rugged industrial service. The cast aluminum impeller alloy has strength qualities far exceeding common aluminum alloys, and the massive hub section makes the entire rotating assembly less sensitive to imbalance. The TCVX AXIFAN® vaneaxial housing and its accessories can also be provided in aluminum or stainless steel construction for corrosive applications.

Smoke Exhaust/Stairway Ventilation

The direct drive Model TCVX is the perfect choice for stairway ventilation. The requirement for stairway pressurization has increased due to more stringent public building codes. During an emergency exit, the need to create a positive pressure within the stairway enclosure ensures a safe exit way. For this application, the Model TCVX AXIFAN® uses a maintenance-free, direct drive motor and the blade adjustability allows fine-tuning of the system to the optimum point of rating.

ATEX

The TCVX AXIFAN® is available for explosive environment applications where fans must meet the European Union's ATEX Manufacturer's Directive (94/9/EC). Currently, Twin City Fan & Blower offers fans suitable for Zone 2 and 22, Category 3 environments with special modifications. Fans modified for ATEX environments are not AMCA certified.

Consult our website (<https://www.tcf.com/applications/atex>) or contact Twin City Fan & Blower for further information.

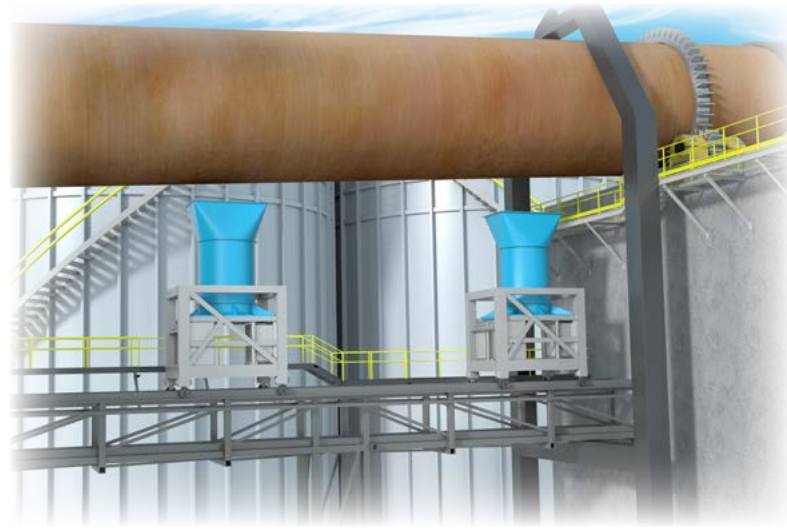

Cement Kiln Application

Sizes and Performance

- Sizes 18" to 84" impeller diameters
- Hub available in 14", 18", 21", 27" and 30" diameters for various hub-to-tip ratios
- Airflow to 233,000 CFM
- Static pressures to 6" w.g.

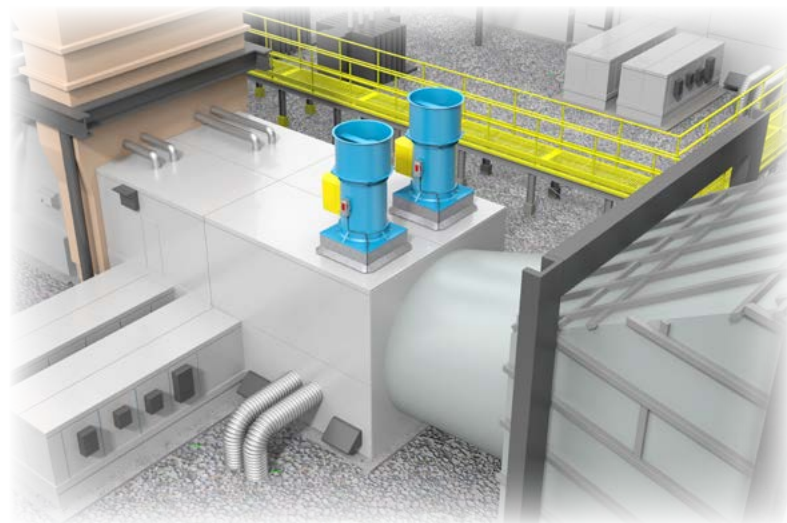

Gas Turbine Plant





Housings - Housings are constructed from one-piece, heavy-gauge, hot-rolled steel. Flanges are provided on both the inlet and outlet and are punched for attachment to ductwork or accessories. The seams are continuously-welded to prevent leakage, thus assuring maximum efficiency.

Impeller/Fan Size Combinations - Fan sizes range from 18" to 84" impeller diameters. Hubs are available in 14", 18", 21", 27" and 30" diameters. The blades can be cut to one of several diameters in order to provide various hub-to-tip ratios. Varying hub-to-tip ratios allow for different pressure and efficiency characteristics and the option of having several different impellers (different hub ratios) for a set diameter. For simplicity, this catalog provides one hub-to-tip ratio for a given fan size. Twin City Fan & Blower's Fan Selector Program can provide performance data for other hub-to-tip ratio combinations. Performance is in 5° blade angle increments. The Twin City Fan & Blower Fan Selector Program can be used to obtain selection for intermediate angles.

Bearings - Heavy-duty, grease lubricated, anti-friction ball or roller, self-aligning, pillow block type bearings, specifically designed for air handling applications to provide an average life (L-50) in excess of 200,000 hours at maximum cataloged operating speeds.

Shaft - AISI 1040 or 1045 hot rolled steel, accurately turned, ground, polished and ring gauged for accuracy.

Drive - Fixed or adjustable pitch V-belt drives with cast iron sheaves and anti-static conducting belts.

Motors - ODP, TEFC and explosion proof, single and three phase motors are carefully matched to the fan load.

Vibration Isolation - Fans can be provided with spring or rubber-in-shear isolators. Spring isolators are standard 1" deflection and can be provided for floor mount or ceiling hung orientation. Flexible connections are required on fans employing vibration isolation. Avoid collapsed flexible connections on the fan inlet.

Inlet/Outlet Screen - Safety screening can be provided for installation in the fan inlet, fan outlet, inlet/outlet cone or inlet bell.

Curb Cap - One-piece curb cap/inlet venturi assembly provides protection from weather. Prepunched mounting holes provide easy and accurate attachment to the roof curb.

Guide Vanes - The fan housing is fitted with airflow straightening guide vanes. These guide vanes are aerodynamically placed within the housing and are located downstream from the impeller. The vanes are stationary and welded to both the inner and outer cylinders to minimize turbulence downstream from the fan. This straightening effect aids the impeller in recovering rotative energy imparted to the air.

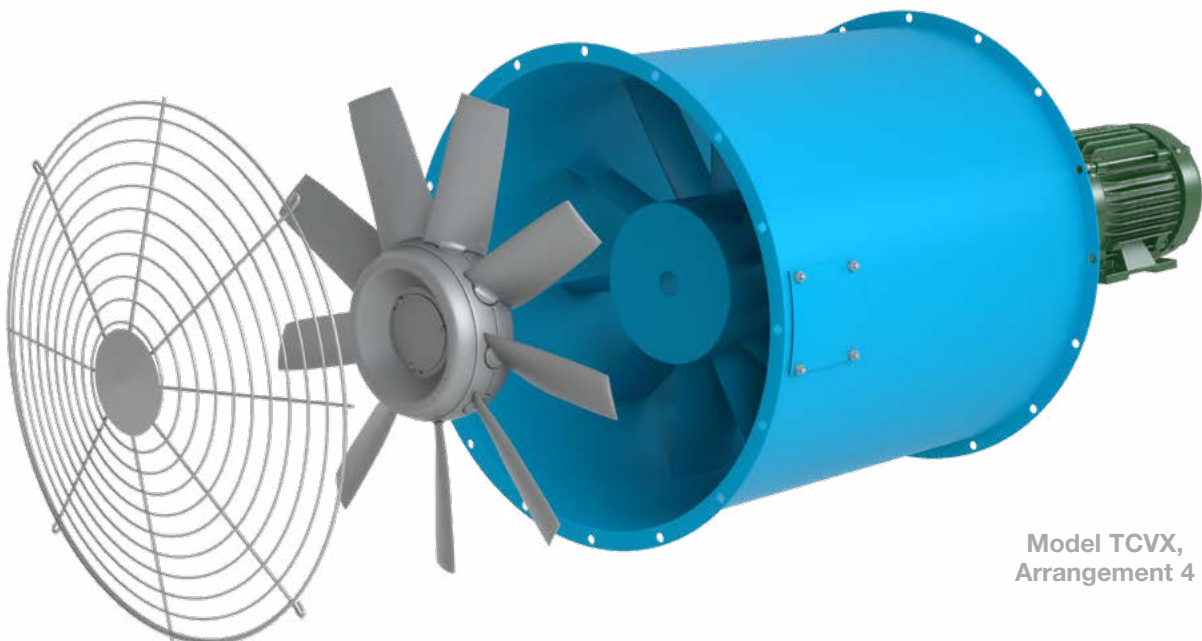

Model TCVX,
Arrangement 4

Spark Resistant Construction

Fan applications may involve the handling of fumes or vapors. Such applications require careful consideration by the system designer to ensure the safe handling of such gases. Twin City Fan & Blower offers spark resistant construction, type B per AMCA Standard 99-0401. It is the specifier's or the user's responsibility to specify the type of spark resistant construction with full recognition of the potential hazards and the degree of protection required.

Type B - The fan shall have a nonferrous impeller and nonferrous rub ring about the opening through which the shaft passes — usually aluminum impeller and rub ring and limited to 275°F. Consult factory for availability.

Swingout Construction

Swingout construction provides easy access to the fan for cleaning and general maintenance without removing it from the ductwork. When quickopen clamp latches are released, the door swings out on heavy-duty hinges to provide out of the airstream access to the impeller for cleaning. For additional access to the shaft and bearings, a split inner cylinder is provided. Available in Sizes 18-54.

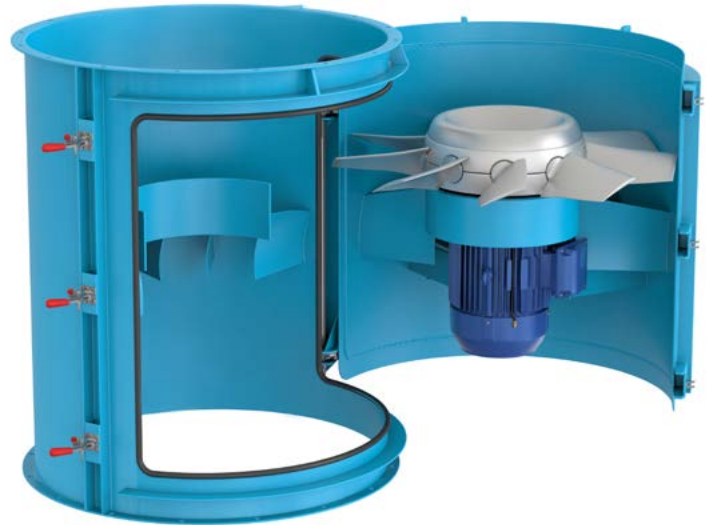

Swingout Construction

Clamshell Construction

Clamshell construction offers quick access to internal components of the fan without removing it from the system. Doors with heavy-duty hinges provide access to the impeller and inner cylinder for cleaning and general maintenance. A split inner cylinder is standard on all clamshell fans for easy access to the shaft and bearings. Available in Sizes 18-72.

Corrosion Resistant Construction

For handling corrosive fumes, etc. Fan casings can be constructed of hot dipped galvanized steel, stainless steel, aluminum or protected with a wide variety of suitable protective coatings such as Epoxy, Phenolic, Siloxane, etc.

High Moisture Modification

A shaft seal and added gaskets to the bearing housing protect the rotor assembly from damage due to moisture ingress. Ideal for steam and high humidity applications.

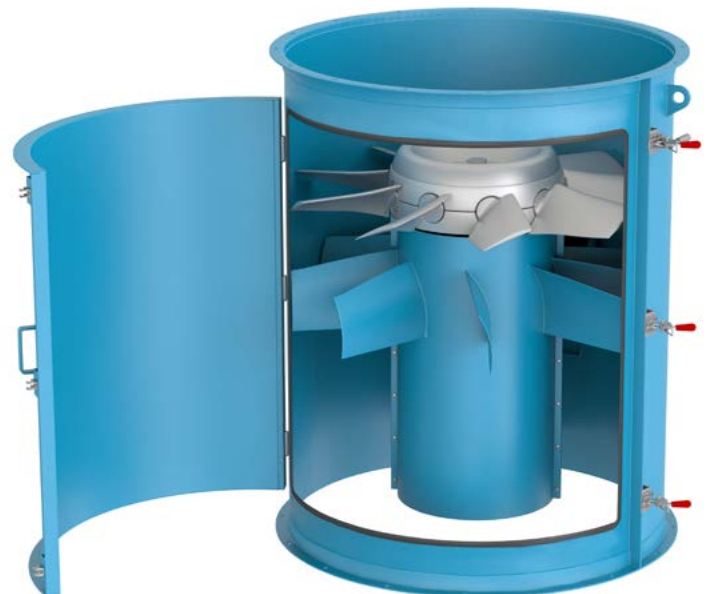

Clamshell Construction

BLADE ADJUSTMENT



The patented TCVX AXIFAN® blade design provides the customer with the ability to modify the blade angle in order to vary the performance when a speed adjustment is impractical or not feasible due to the absence of a variable frequency drive.

The blade angle is indexed in the area where the blade and hub meet. The ratings displayed in this catalog indicate the specific blade angle required and the blade should be set accordingly.

The fan name tag, supplied on the housing exterior, indicates the CFM, static pressure and corresponding blade angle setting for the specified flow rate and pressure.

Blade pitch adjustments can be accomplished by accessing the fan inlet, removing the aerodynamic hub cover and loosening the bolts that clamp the hub on either side of the blade sockets. See our installation and maintenance manual for specific instructions. When adjusting the blade angle, care must be taken not to overload the fan motor. Refer to the fan curves or consult your Twin City Fan & Blower sales representative to assure the fan is properly applied. Further care must be taken to be sure that all fan blades are adjusted to the same blade angle, thus ensuring proper airflow characteristics and balance.



TCVX Adjustable
Pitch Impeller



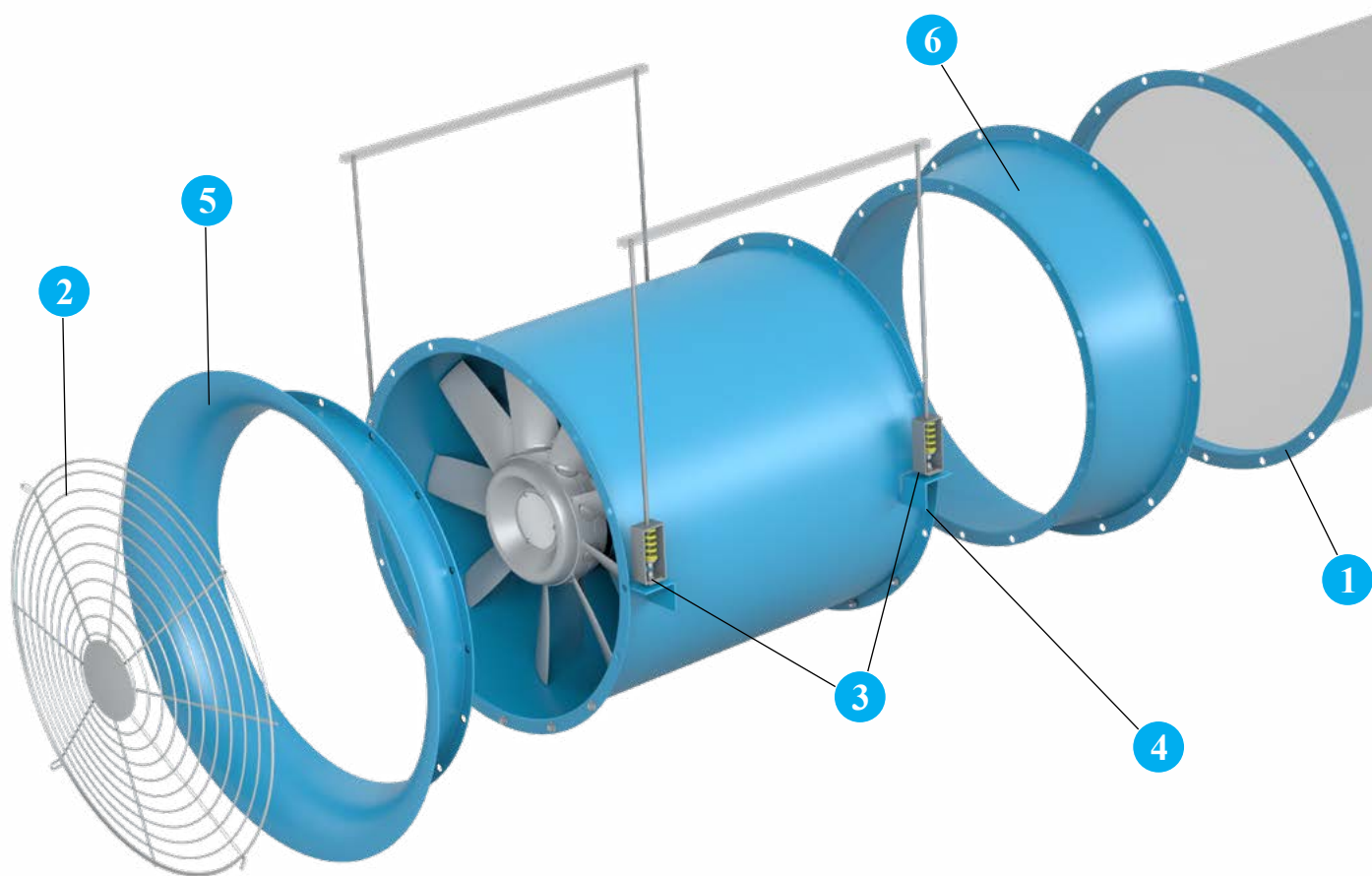

1 Outlet Companion Flange Companion flanges are commonly connected to a user's duct for easy installation of flexible connections between the fan and duct. Companion flanges and flex connectors are punched to match the fan's inlet or outlet hole patterns.

2 Inlet Screens Heavy-gauge screen mounted to fan inlet/outlet for easy removal.

3 Ceiling Spring Isolators All Model TCVX fans can be provided with spring or rubber-in-shear isolators. Spring isolators are standard 1" deflection and can be provided for floor mount or ceiling hung orientation. Flexible connections are required on fans employing vibration isolation. Avoid collapsed flexible connections on the fan inlet.

4 Suspension Clips For horizontal flow with ceiling mounting, four clips of formed angle are welded to the fan housing for suspension via tie rods to the ceiling support structure.

5 Inlet Bell An inlet bell is recommended to minimize entrance losses for installations where the inlet of the fan is nonducted. Inlet bell is flanged and punched to mate up with the standard flanged inlet.

6 Inlet/Outlet Cone Heavy-gauge and flanged to match the fan flange bolt pattern to ensure smooth airflow and regain of velocity pressure.

Other Accessories Include:

- Access Door (General Observation)
- Shaft Seal
- RIS Isolators
- Roof Ventilator Packages (Upblast/Hooded or Filtered/Non-Filtered)
- Support Legs



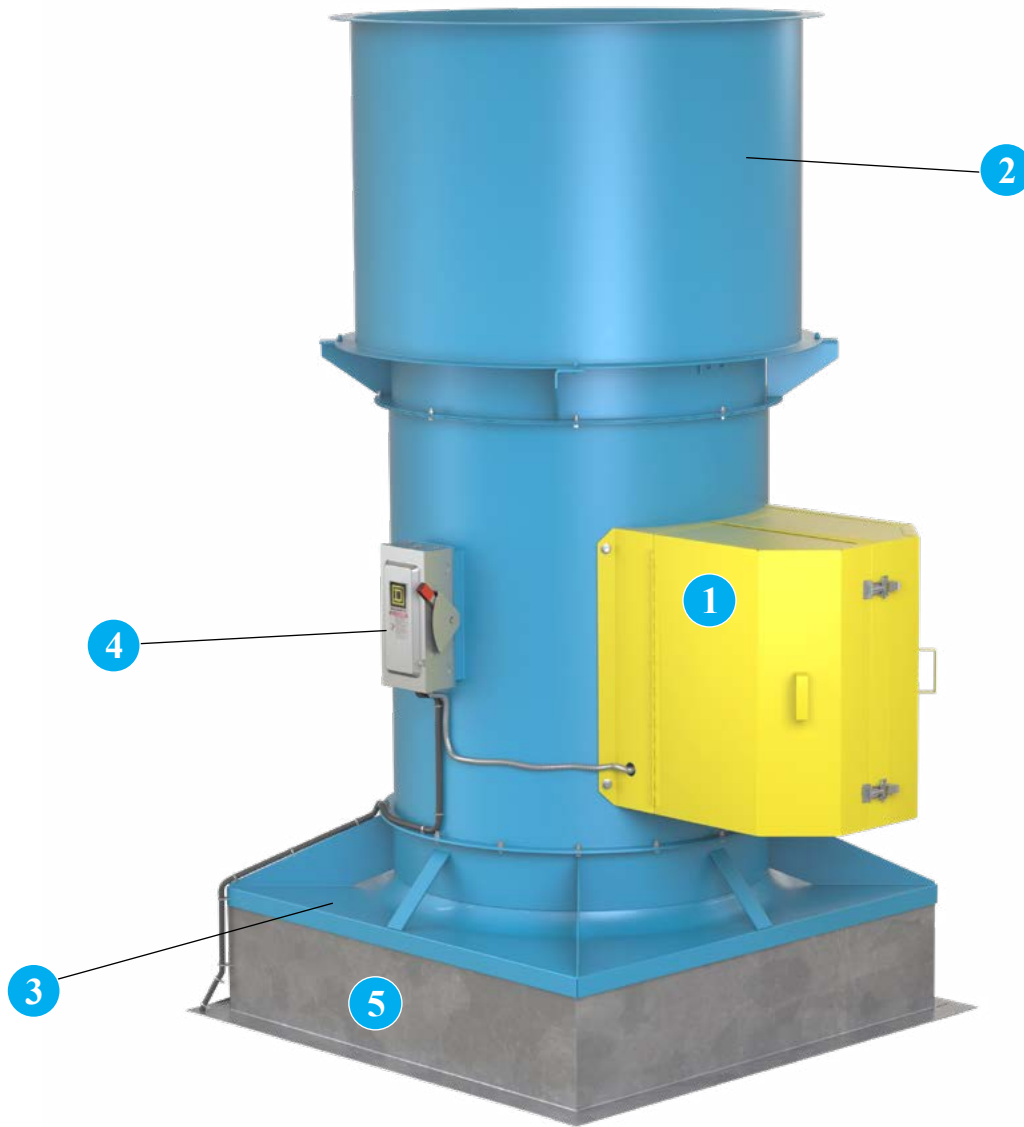

- 1 Weather Cover** For outdoor installations, the weather cover completely encloses the motor and V-belt drive from the elements. Available in one-piece or clamshell construction. Provided with slots for ventilation, the cover is easily removable for inspection and maintenance. Weather covers are available for either horizontal or vertical flow fans.
- 2 Stack Cap** Designed for vertical discharge with butterfly type dampers to seal out the weather when the fan is shut off and minimal flow obstruction when the fan is operating.
- 3 Curb Cap** Model TCVX units can be supplied with a base (curb cap), attached to the fan's flange for curb mounting. The combination of a curb cap and stack cap creates an upblast-style power roof ventilator.
- 4 NEMA 3R Disconnect Switch** Disconnect switches offer superior environmental protection. From waterproofing to hazardous environments, know that you and your equipment are safe. Positive electrical shutoff during fan cleaning or maintenance provides additional safety and peace of mind. For more information about disconnect switches, see page 11.
- 5 Self-Flashing Roof Curb** Prefabricated roof curbs are available in heavy-duty galvanized steel or aluminum construction, in heights of 8", 12" or 18". The self-flashing style curb is provided with a factory installed wood nailer. Curbs are provided with 1.5" of insulation as standard and feature continuously-welded seams for added rigidity and moisture protection. Prefabricated curbs are also available in raised cant, pitched and peak models.

Horizontal Construction

Horizontal construction is available in sizes 18 through 84.

Horizontal Base Mounted (HBM) — Support legs are provided at each end of the fan for floor mounting.

Horizontal Ceiling Hung (HCH) — For duct mounted fans, four suspension clips are welded to the fan casing to allow ceiling suspension using rod hangers.

Horizontal (HOR) — For mounting configurations where support legs and suspension clips are not required.

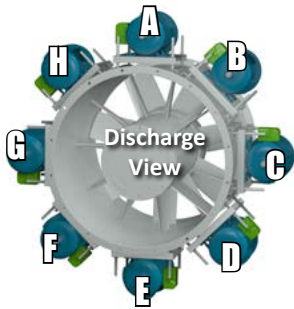

HCH
Horizontal
Ceiling Hung

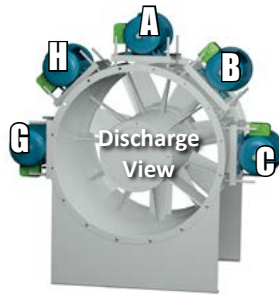

HBM
Horizontal Base
Mounted



HOR
Horizontal
Flange Mounted

Vertical Construction

Vertical construction is available in sizes 18 through 54. Consult factory for larger sizes.

Floor or Ceiling Mounted (VUI/VUO/VDI/VDO) — Four vertical brackets are welded to either end of the fan housing. Bracket location is determined by airflow direction and support details (see below).

Roof Mounted (VRM) — A curb cap provides weathertight seal for roof curb mounted fans. A stack cap and weather cover are also available for the upblast style roof ventilator.

Vertical (VUN/VDN) — For mounting configurations where support brackets are not required.



VUS
Vertical Upblast
with Stack Cap

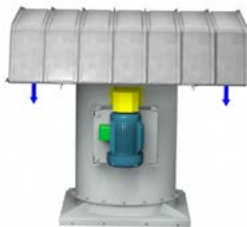

VUH
Vertical Upblast
with Hood and
Curb Cap

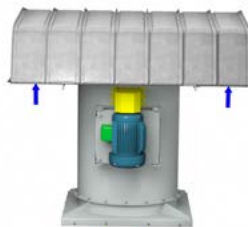

VDH
Vertical Downblast
with Hood and
Curb Cap

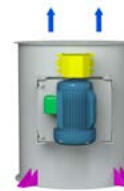

VUI
Vertical Discharge Up,
Floor Mount Support
Brackets On Inlet



VUO
Vertical Discharge Up,
Ceiling Hung Support
Brackets On Outlet



VUN
Vertical Up
No Brackets



VDI
Vertical Discharge Down,
Ceiling Hung Support
Brackets On Inlet



VDO
Vertical Discharge Down,
Floor Mount Support
Brackets On Outlet



VDN
Vertical Down
No Brackets

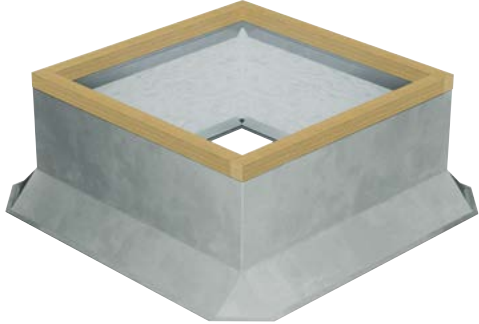

Canted Roof Curbs

- Constructed of galvanized steel with continuously-welded seams
- Large 3" built-in 45° cant to accommodate roofing material to top of curb. Cant is beveled at corners for better support of roofing material
- Wood nailer (1½") secured to top ledge
- Lined with 1½" fiberglass fire-resistant, sound-absorbing insulation
- Damper shelf standard
- Options: Aluminum construction, burglar security bars, metal liner (galvanized or aluminum), special heights up to 24".



Self-Flashing & Straight-Sided Roof Curbs

- Constructed of galvanized steel with continuously-welded seams
- Wide base plate (flashing) to ensure watertight seal to roof
- Top ledge covered with ¾" polystyrene gasket (self-flashing) for weather seal and to reduce metal-to-metal conducted noise
- Wood nailer secured to top ledge (straight-sided)
- Lined with 1½" fiberglass fire-resistant, sound-absorbing insulation
- Damper shelf standard
- Straight-sided roof curbs are constructed with the same features as the self-flashing curbs, but are one dimensional to allow for field supplied cants and roofing material to be brought up to the top of the curb
- Options: Aluminum construction, burglar security bars, metal liner (galvanized or aluminum), special heights up to 24", single- or double-pitched curbs for sloping roofs

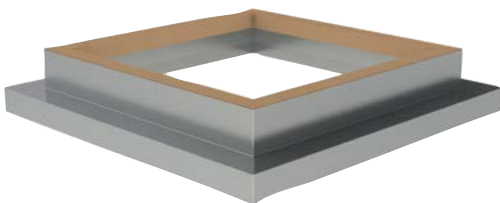

Curb Adapters

- Constructed of galvanized steel with continuously-welded seams
- Top ledge covered with ¾" polystyrene gasket to reduce metal-to-metal conducted noise and act as a weather seal
- Available in enlarger or reducer (shown) models



Disconnect switches provide positive electrical shutoff during fan cleaning or maintenance.

NEMA 3R Disconnect Switch

A NEMA 3R, rain proof, disconnect is available shipped loose for field mounting and wiring or factory mounted and wired externally.



NEMA 3R
Disconnect Switch



NEMA 4
Disconnect Switch

NEMA 4 Disconnect Switch

A NEMA 4, water and dust tight, disconnect is available shipped loose for field mounting and wiring or factory mounted and wired externally.

NEMA 7/9 Disconnect Switch

A NEMA 7/9 disconnect switch is recommended on fans with explosion proof motors. The NEMA 7/9 switch is designed for use with fans operating in hazardous environments. Available shipped loose for field mounting and wiring.



NEMA 7/9
Disconnect Switch



INSTALLATION PHOTOS



Paint Booth Exhaust



Cement Kiln Cooling



Paint Booth Exhaust

Bare Fan Weights (lb)

FAN SIZE	ARRANGEMENT 4																				
	CLASS I - HUB RATIO							CLASS II - HUB RATIO							CLASS III - HUB RATIO						
	2	3	4	5	6	7	8	2	3	4	5	6	7	8	2	3	4	5	6	7	8
18	—	—	—	—	—	—	169	—	—	—	—	—	—	198	—	—	—	—	—	—	208
21	—	—	—	—	—	—	226	—	—	—	—	—	276	—	—	—	—	—	—	290	—
24	—	—	—	—	267	—	—	—	—	—	—	303	—	—	—	—	—	318	—	—	—
28	—	—	—	296	—	417	—	—	—	—	348	—	465	—	—	—	372	—	471	—	—
32	—	—	328	—	443	612	—	—	—	378	—	497	670	—	—	—	395	—	519	692	—
36	—	—	—	498	650	—	—	—	—	—	566	716	—	—	—	—	594	752	—	—	—
42	—	—	688	845	—	922	—	—	—	824	998	—	1078	—	—	—	865	993	—	1152	—
48	—	—	950	—	1200	1380	—	—	—	1060	—	1315	1515	—	—	—	1113	—	1451	1691	—
54	—	1065	—	1135	1310	—	—	—	1270	—	1340	1545	—	—	—	1334	—	1388	1742	—	—
60	—	—	1325	1525	—	—	—	—	—	1490	1715	—	—	—	—	—	1543	1757	—	—	—
66	—	1560	1795	—	—	—	—	—	1560	1795	—	—	—	—	—	1618	1842	—	—	—	—
72	1675	1930	—	—	—	—	—	1675	1930	—	—	—	—	—	1739	1981	—	—	—	—	—
84	2100	—	—	—	—	—	—	2100	—	—	—	—	—	—	2159	—	—	—	—	—	—

FAN SIZE	ARRANGEMENT 9																				
	CLASS I - HUB RATIO							CLASS II - HUB RATIO							CLASS III - HUB RATIO						
	2	3	4	5	6	7	8	2	3	4	5	6	7	8	2	3	4	5	6	7	8
18	—	—	—	—	—	—	185	—	—	—	—	—	—	220	—	—	—	—	—	—	233
21	—	—	—	—	—	244	—	—	—	—	—	—	294	—	—	—	—	—	—	338	—
24	—	—	—	—	295	—	—	—	—	—	—	335	—	—	—	—	—	367	—	—	—
28	—	—	—	315	—	450	—	—	—	—	365	—	498	—	—	—	423	—	531	—	—
32	—	—	355	—	485	646	—	—	—	409	—	535	696	—	—	—	469	—	579	740	—
36	—	—	—	534	695	—	—	—	—	—	600	760	—	—	—	—	692	843	—	—	—
42	—	—	728	889	—	978	—	—	—	860	1037	—	1126	—	—	—	992	1169	—	1178	—
48	—	—	1027	—	1270	1460	—	—	—	1134	—	1380	1590	—	—	—	1284	—	1440	1670	—
54	—	1125	—	1160	1340	—	—	—	1330	—	1365	1570	—	—	—	1499	—	1432	1649	—	—
60	—	—	1537	1775	—	—	—	—	—	1735	2000	—	—	—	—	—	1809	2100	—	—	—
66	—	1935	2245	—	—	—	—	—	1995	2295	—	—	—	—	—	2077	2410	—	—	—	—
72	2135	2460	—	—	—	—	—	2235	2570	—	—	—	—	—	2324	2699	—	—	—	—	—
84	2675	—	—	—	—	—	—	2795	—	—	—	—	—	—	2935	—	—	—	—	—	—

Accessory Weights (lb)

FAN SIZE	BELT GUARD	MOTOR COVER	INLET / OUTLET SCREEN	INLET BELL	INLET / OUTLET CONE	COMPANION FLANGE	SUPPORT LEGS		INLET VANES	STACK CAP	CURB CAP	SUSPENSION CLIPS
							HORIZ. FLOW	VERT. FLOW				
18	8	18	4	16	12	10	12	10	60	55	17	3
21	10	21	5	21	13	11	20	10	62	65	23	3
24	11	23	7	30	20	13	24	17	68	78	26	4
28	12	26	8	40	22	15	32	17	71	98	34	4
32	14	32	10	54	25	17	47	17	80	120	45	4
36	16	34	11	82	52	19	58	17	89	165	51	4
42	18	40	13	100	62	25	83	19	98	230	64	4
48	21	45	18	114	70	33	97	19	107	288	72	4
54	25	56	24	128	76	37	126	26	116	384	82	5
60	30	68	33	139	86	41	265	26	134	400	133	5
66	50	93	48	157	101	48	295	36	160	450	195	7
72	70	125	68	186	121	57	370	36	178	500	270	7
84	70	132	98	490	260	70	425	36	365	700	310	8

Housing Gauges

FAN SIZE	ARRANGEMENT 4			ARRANGEMENT 9		
	CL I	CL II	CL III	CL I	CL II	CL III
18	10	7	7	12	7	7
21	10	7	7	12	7	7
24	10	7	7	10	7	7
28	10	7	7	10	7	7
32	10	7	7	10	7	7
36	10	7	7	10	7	7
42	7	0.25	0.25	7	0.25	0.25
48	7	0.25	0.25	7	0.25	0.25
54	7	0.25	0.25	7	0.25	0.25
60	0.25	0.25	0.25	7	0.25	0.25
66	0.25	0.25	0.25	0.25	0.25	0.25
72	0.25	0.25	0.25	0.25	0.25	0.25
84	0.25	0.25	0.25	0.25	0.25	0.25

Stack Cap Limits

FAN SIZE	MINIMUM CFM TO OPEN		MAXIMUM CFM
	STAINLESS	ALUMINUM	
18	3058	2339	5577
21	4163	3184	7592
24	5426	4150	9895
28	7400	5659	13494
32	9644	7375	17586
36	12184	9317	22218
42	16650	12732	30361
48	21709	16601	39587
54	27404	20956	49972
60	33779	25831	61597
66	—	—	—
72	—	—	—
84	—	—	—

ARR. 4 – HORIZONTAL

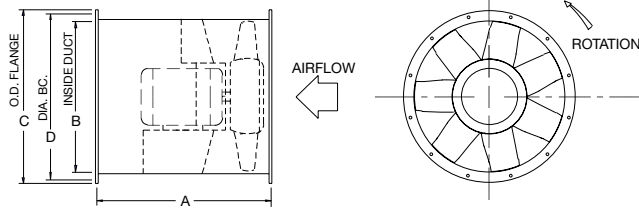

ARR. 9 – HORIZONTAL

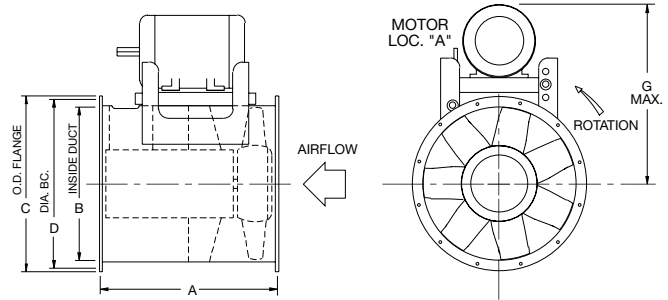

HORIZONTAL DISCHARGES

HOR = Horizontal – No Clips or Legs **HCH** = Horizontal Ceiling Hung with Suspension Clips **HBM** = Horizontal Base Mounted with Support Legs

ARR. 4 – VERTICAL

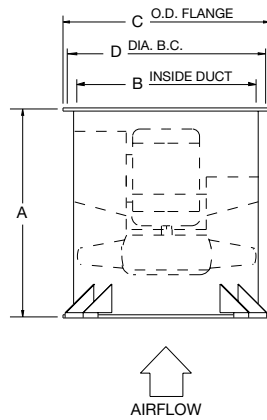

ARR. 9 – VERTICAL

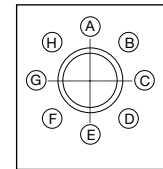
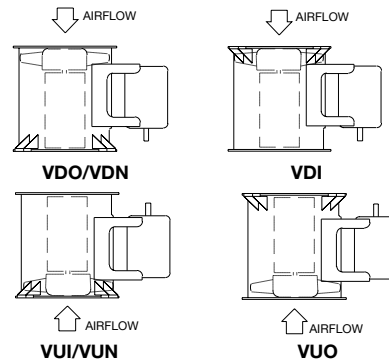
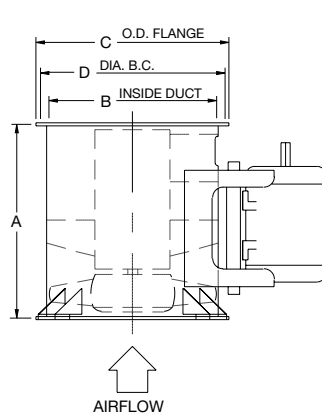

HORIZONTAL MOTOR LOCATIONS (VIEWED FROM FAN OUTLET)

VERTICAL DISCHARGES

VDO = Vertical Down Floor Mounted With Legs **VDI** = Vertical Down Ceiling Hung With Legs **VUN** = Vertical Up Discharge Without Legs
VDN = Vertical Down Discharge Without Legs **VUI** = Vertical Up Floor Mounted With Legs **VUO** = Vertical Up Ceiling Hung With Legs

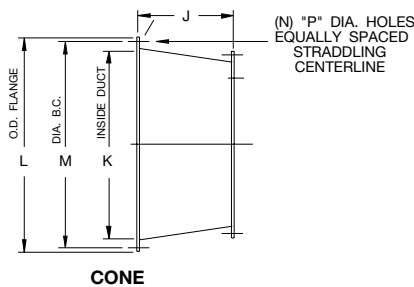

CONE

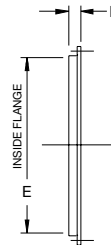

COMPANION FLANGE

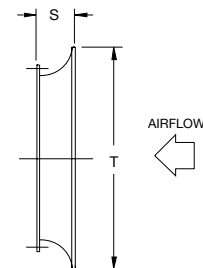

INLET BELL

FAN SIZE	COMPANION FLANGE		CONE						INLET BELL		FAN AREA (FT ²)	CONE AREA (FT ²)
	E	F	J	K	L	M	N	P	S	T		
18	18.16	1.50	8.50	21.19	24.50	22.88	8	0.56	3.71	23.72	1.80	2.45
21	21.19	1.50	8.50	24.19	27.50	25.88	12	0.56	4.31	27.67	2.45	3.19
24	24.19	1.50	11.50	28.25	31.56	30.00	12	0.56	4.96	31.63	3.19	4.35
28	28.25	1.50	11.50	32.25	35.56	34.00	12	0.56	5.75	36.90	4.35	5.67
32	32.25	1.50	11.50	36.25	39.56	38.00	16	0.56	6.54	42.17	5.67	7.17
36	36.25	1.50	17.00	42.38	46.81	44.63	16	0.69	7.39	47.44	7.17	9.80
42	42.38	2.00	17.00	48.38	52.81	50.63	16	0.69	8.59	55.34	9.80	12.77
48	48.38	2.00	17.00	54.38	58.69	56.63	16	0.69	9.76	63.25	12.77	16.13
54	54.38	2.00	17.00	60.38	64.94	63.38	20	0.69	10.98	71.16	16.13	19.88
60	60.38	3.00	17.00	66.44	70.94	69.38	24	0.69	12.20	79.06	19.88	24.08
66	66.44	3.00	17.00	72.94	76.94	75.50	24	0.81	11.75	78.88	24.08	29.02
72	72.44	3.00	33.00	84.50	91.13	88.00	24	0.81	12.00	84.00	28.62	38.94
84	CF	CF	34.00	96.63	103.00	100.00	24	0.75	12.00	96.19	38.94	50.79

CF = CONSULT FACTORY

AC13716M

DIMENSIONS ARE NOT TO BE USED FOR CONSTRUCTION. CERTIFIED DRAWINGS AVAILABLE UPON REQUEST.

FAN SIZE	A ARRANGEMENT 9 — HUB RATIO													
	2		3		4		5		6		7		8	
	CL I & II	CL III	CL I & II	CL III	CL I & II	CL III	CL I & II	CL III	CL I & II	CL III	CL I & II	CL III	CL I & II	CL III
18	—	—	—	—	—	—	—	—	—	—	—	—	—	—
21	—	—	—	—	—	—	—	—	—	—	—	—	—	—
24	—	—	—	—	—	—	—	—	—	—	—	—	—	—
28	—	—	—	—	—	—	—	—	—	—	—	—	—	—
32	—	—	—	—	36.25	47.00	—	—	—	—	—	—	—	—
36	—	—	—	—	—	—	40.25	55.00	47.00	60.25	—	—	—	—
42	—	—	—	—	47.00	60.25	47.00	60.25	—	—	—	—	—	—
48	—	—	—	—	47.00	60.25	—	—	—	—	—	—	—	—
54	—	—	47.00	60.25	—	—	55.00	60.25	60.25	60.25	—	—	—	—
60	—	—	—	—	55.00	60.25	60.25	60.25	—	—	—	—	—	—
66	—	—	55.00	60.25	60.25	60.25	—	—	—	—	—	—	—	—
72	55.00	60.25	60.25	60.25	—	—	—	—	—	—	—	—	—	—
84	60.25	60.25	—	—	—	—	—	—	—	—	—	—	—	—

AC13956D
AC13957D
AC13961G
AC13962H
AC16151B
AC16152C
AC16156C
AC16157D
AC1001172
AC1001173
AC1001176
AC1001177
AC1001178
AC1001179

FAN SIZE	A ARRANGEMENT 4 — HUB RATIO																				
	2			3			4			5			6			7			8		
	CL I	CL II	CL III	CL I	CL II	CL III	CL I	CL II	CL III	CL I	CL II	CL III	CL I	CL II	CL III	CL I	CL II	CL III	CL I	CL II	CL III
18	—	—	—	—	—	—	—	—	—	—	—	—	—	—	—	—	—	—	22.00	27.00	27.00
21	—	—	—	—	—	—	—	—	—	—	—	—	—	—	—	—	—	—	—	—	—
24	—	—	—	—	—	—	—	—	—	—	—	—	—	—	—	—	—	—	—	—	—
28	—	—	—	—	—	—	—	—	—	—	—	—	—	—	—	—	—	—	—	—	—
32	—	—	—	—	—	—	27.00	29.00	32.00	—	—	—	—	—	—	—	—	—	—	—	—
36	—	—	—	—	—	—	—	—	—	—	—	—	—	—	—	—	—	—	—	—	—
42	—	—	—	—	—	—	36.25	42.50	42.50	40.25	42.50	42.50	—	—	—	—	—	—	—	—	—
48	—	—	—	—	—	—	42.50	45.00	45.00	—	—	—	—	—	—	—	—	—	—	—	—
54	—	—	—	40.25	47.00	47.00	—	—	—	—	—	—	—	—	—	—	—	—	—	—	—
60	—	—	—	—	—	—	45.00	53.25	57.00	45.00	63.00	66.00	—	—	—	—	—	—	—	—	—
66	—	—	—	45.00	53.25	57.00	45.00	63.00	66.00	—	—	—	—	—	—	—	—	—	—	—	—
72	45.00	53.25	57.00	45.00	63.00	66.00	—	—	—	—	—	—	—	—	—	—	—	—	—	—	—
84	45.00	63.00	66.00	—	—	—	—	—	—	—	—	—	—	—	—	—	—	—	—	—	—

FAN SIZE	B	C (MAX.)	D	G (MAX.)		
				CL I	CL II	CL III
18	18.16	21.16	19.88	27.50	29.13	29.13
21	21.19	24.19	22.88	31.75	31.88	31.88
24	24.19	27.19	25.88	34.50	33.75	33.75
28	28.25	31.25	30.00	38.25	39.63	39.63
32	32.25	35.25	34.00	41.00	41.56	41.56
36	36.25	40.25	38.00	45.25	47.13	47.13
42	42.38	46.38	44.63	49.50	52.75	52.75
48	48.38	53.38	50.63	53.25	56.88	56.88
54	54.38	59.38	56.63	59.00	62.88	62.88
60	60.38	66.38	63.38	60.25	66.44	66.44
66	66.44	72.44	69.38	64.00	69.88	69.88
72	72.50	78.50	75.50	67.25	73.25	73.25
84	84.50	90.50	88.00	73.25	79.25	79.25

FAN SIZE	MAXIMUM MOTOR FRAME		
	ARRANGEMENT 9		
	CL I	CL II	CL III
18	215T	256T	256T
21	256T	256T	256T
24	256T	286T	286T
28	286T	326T	365T
32	286T	326T	405T
36	326T	365T	405T
42	326T	405T	445T
48	365T	405T	445T
54	365T	445T	445T
60	365T	445T	445T
66	365T	445T	445T
72	365T	445T	445T
84	365T	445T	445T

FAN SIZE	MAXIMUM MOTOR FRAME																							
	ARRANGEMENT 4 — CL I — HUB RATIO								ARRANGEMENT 4 — CL II — HUB RATIO															
	2	3	4	5	6	7	8	2	3	4	5	6	7	8	2	3	4	5	6	7	8			
18	—	—	—	—	—	—	145T	—	—	—	—	—	—	—	—	—	—	—	—	—	—	—	—	—
21	—	—	—	—	—	—	145T	—	—	—	—	—	—	—	—	—	—	—	—	—	—	—	—	—
24	—	—	—	—	184T	—	—	—	—	—	—	—	—	—	—	—	—	—	—	—	—	—	—	—
28	—	—	—	184T	—	215T	—	—	—	—	256T	—	286T	—	—	—	—	—	—	—	—	—	—	—
32	—	—	256T	—	256T	256T	—	—	—	256T	—	326T	326T	—	—	—	—	—	—	—	—	—	—	—
36	—	—	—	256T	256T	—	—	—	—	—	—	326T	326T	—	—	—	—	—	—	—	—	—	—	—
42	—	—	286T	326T	—	326T	—	—	—	326T	365T	—	405T	—	—	—	—	—	—	—	—	—	—	—
48	—	—	326T	—	326T	365T	—	—	—	365T	—	365T	405T	—	—	—	—	—	—	—	—	—	—	—
54	—	326T	—	365T	365T	—	—	—	405T	—	445T	445T	—	—	—	—	—	—	—	—	—	—	—	—
60	—	—	365T	365T	—	—	—	—	—	445T	449T	—	—	—	—	—	—	—	—	—	—	—	—	—
66	—	365T	365T	—	—	—	—	—	—	445T	449T	—	—	—	—	—	—	—	—	—	—	—	—	—
72	365T	365T	—	—	—	—	—	—	—	445T	449T	—	—	—	—	—	—	—	—	—	—	—	—	—
84	365T	—	—	—	—	—	—	—	—	449T	—	—	—	—	—	—	—	—	—	—	—	—	—	—

DIMENSIONS ARE NOT TO BE USED FOR CONSTRUCTION. CERTIFIED DRAWINGS AVAILABLE UPON REQUEST.



Model TCVX

Fans, where indicated on drawings and schedules, shall be Arrangement 9, Model TCVX AXIFAN® Adjustable Blade Vaneaxial with the impeller mounted on a separate shaft and bearings supported completely within an enclosed tube isolated from the high velocity airstream or Arrangement 4, Model TCVX AXIFAN® Adjustable Blade Vaneaxial with the impeller mounted directly on the motor shaft and with the impeller and motor assembly enclosed entirely within the fan casing.

PERFORMANCE — Fans shall be tested in accordance with AMCA 211 and AMCA 311 test codes for air moving devices and shall be guaranteed by the manufacturer to deliver rated published performance levels. Fans shall be licensed to bear the AMCA certified ratings seal for both sound and air.

CONSTRUCTION — Fan housings shall be of welded one-piece, hot rolled steel. The housing seam shall be continuously-welded and ground smooth for less resistance to airflow. Inlet and outlet flanges are standard.

GUIDE VANES — Fan housings shall be fitted with eleven aerodynamically designed stationary straightening guide vanes on the air discharge side of the fan impeller. Vanes shall be welded to both the housing and the inner cylinder and act to straighten the swirling motion of the air downstream of the fan blades, thereby recovering rotational energy losses, improving efficiency and static pressure capability, reducing power requirements, and reducing fan noise generation.

IMPELLER — The fan impeller shall be of individually manually adjustable blade pitch design and shall consist of a hub and blade assembly of aluminum alloy castings. The impeller shall have blades of airfoil shape designed with a variable hub ratio system to allow the selected fan to operate at the highest efficiency possible. The blade pitch angle shall be field adjustable by accessing the fan inlet. Blade angle markings shall be permanently cast into each blade socket on the hub and a corresponding index mark shall be permanently cast into the blade root. The fan impeller assembly shall be machined to the proper diameter so that blade tip clearance shall be within tolerance necessary to ensure certified fan performance. The fan impeller shall be secured to the fan/motor shaft with a taperlock bushing. The blade angle is to be factory set at the blade angle required to achieve the specified flow rate and pressure. This blade angle shall be indicated on the fan nameplate.

SHAFT (ARR. 9 ONLY) — Shafts shall be AISI 1040 or 1045 hot rolled steel, accurately turned, ground, polished, and ring gauged for accuracy. Shafts shall be sized for the first critical speed of at least 1.43 times the maximum speed.

BEARINGS (ARR. 9 ONLY) — Bearings shall be heavy-duty, grease lubricated, anti-friction ball or roller, self-aligning, pillow block type and selected for a minimum average bearing life (AFBMA L-50) in excess of 200,000 hours at the maximum fan RPM. All bearings shall be provided with pre-filled factory extended lubrication lines fitted with grease fittings terminating at the housing exterior.

DRIVE (ARR. 9 ONLY) — Fans shall be equipped with a (fixed/adjustable) pitch V-belt drive selected to operate at the required RPM. The V-belt drive is to consist of cast iron sheaves and anti-static conducting belts. Drives shall be selected with a (1.5) service factor based upon the required brake horsepower of the fan.

The complete fan shaft and bearing assembly is mounted within a steel fabricated inner cylinder. The V-belt drive assembly is extended through a two-piece belt fairing which is continuously-welded to both the housing and inner cylinder, thus avoiding any direct contact between the belts and high velocity airstream. The belt fairing is to be an aerodynamically shaped tube designed to maximize fan efficiency, minimize air blockage and reduce noise generation.



MOTOR — Motors for Arrangement 9 fans shall be manufactured in accordance with current applicable standards of IEEE and NEMA and, where applicable, shall meet current NEMA Premium Efficiency standards. Motors shall be foot-mounted, NEMA standard (ODP, TEFC, Explosion-Proof), continuous-duty, ball bearing type with class (B, F) insulation and of cast iron construction when commercially available.

Motors for Arrangement 4 fans shall be foot-mounted, NEMA standard, totally enclosed fan cooled (TEFC), continuous-duty, ball bearing type with class “F” insulation and of cast iron construction when commercially available. For ease in wiring the motor, wiring connections shall be extended to an exterior conduit box located on the exterior of the fan casing. A duplicate motor nameplate is to be mounted on the exterior of the fan adjacent to the fan nameplate. External grease fittings with pre-filled factory extended grease leads shall be supplied for lubrication of the motor bearings on all motors that provide grease fittings. Motor bearings shall have a minimum of L-10 life as defined by AFBMA of at least 40,000 hours (200,000 hours average life).

FINISH — All mild steel parts, excluding the rotor assembly, shall be thoroughly degreased and deburred per SSPC – SP1 before application of a polyester powder coating (1.8 to 3.0 mils DFT). The fan shaft shall be coated with a petroleum-based rust protectant. Aluminum components shall be unpainted. Impeller assembly hardware shall be protected from corrosion with an inorganic, zinc-aluminum finish per ASTM F2833.

ACCESSORIES — When specified, accessories shall be provided by Twin City Fan to maintain one-source responsibility.

FACTORY RUN TEST — All fans with motors and drives mounted by Twin City Fan shall be completely assembled and test run as a unit at the specified operating speed prior to shipment. Each impeller shall be statically and dynamically balanced in accordance with ANSI/AMCA 204-96 “Balance Quality and Vibration Levels for Fans” to Fan Application Category BV-3, Balance Quality Grade G6.3. Balance readings shall be taken by electronic type equipment in the axial, vertical, and horizontal directions on each of the bearings. Records shall be maintained and a written copy shall be available upon request.

GUARANTEE — The manufacturer shall guarantee the workmanship and materials for its Model TCVX adjustable blade vaneaxial fans for at least one (1) year from startup or eighteen (18) months from shipment, whichever occurs first.



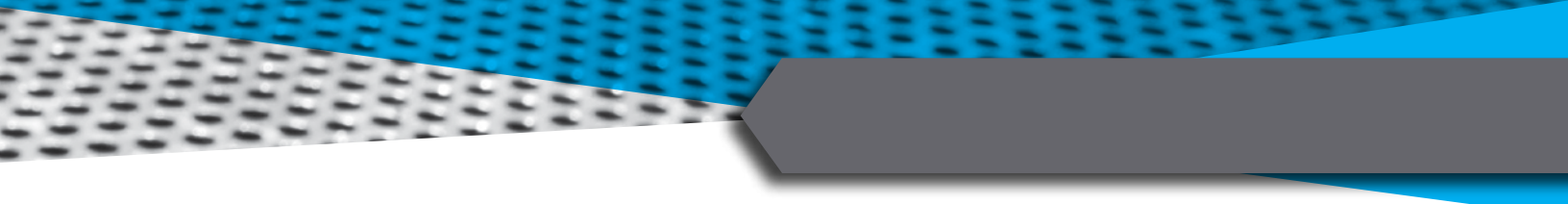

INDUSTRIAL PROCESS AND COMMERCIAL VENTILATION SYSTEMS

CENTRIFUGAL FANS | UTILITY SETS | PLENUM & PLUG FANS | INLINE CENTRIFUGAL FANS
MIXED FLOW FANS | TUBEAXIAL & VANEAXIAL FANS | WALL MOUNTED FANS | ROOF VENTILATORS
CENTRIFUGAL ROOF & WALL EXHAUSTERS | CEILING VENTILATORS | GRAVITY VENTILATORS | DUCT BLOWERS
RADIAL BLADED FANS | RADIAL TIP FANS | HIGH EFFICIENCY INDUSTRIAL FANS | PRESSURE BLOWERS
LABORATORY EXHAUST FANS | FILTERED SUPPLY FANS | MANCOOLERS | FIBERGLASS FANS | CUSTOM FANS



TWIN CITY FAN & BLOWER
WWW.TCF.COM

5959 TRENTON LANE N | MINNEAPOLIS, MN 55442 | PHONE: 763-551-7600 | FAX: 763-551-7601

©2020 Twin City Fan Companies, Ltd., Minneapolis, MN. All rights reserved. Catalog illustrations cover the general appearance of Twin City Fan & Blower products at the time of publication and we reserve the right to make changes in design and construction at any time without notice.