



INDUSTRIAL PROCESS AND
COMMERCIAL VENTILATION SYSTEMS

FIBERGLASS VENTILATORS

FA/FAB | WA/WAB | SA | HA/HAB | MA



FIBERGLASS ROOF VENTILATORS



Fiber-Aire®

**FA/FAB | WA/WAB | SA
I HA/HAB | MA**



Application

The Fiber-Aire® FA/FAB fiberglass centrifugal roof ventilator fans are available with direct drive or belt drive for general ventilation requirements where a low noise level exhaust is desired. The fiberglass housing of this fan is virtually dent, crack, and break proof and is highly resistant to a wide array of chemicals. The motor is completely separated from the airstream, as are the belts and drive components of the belt driven model.

The fiberglass housing actually absorbs noise and vibration, and the specially molded throat and outlet designs minimize loss from friction and turbulence.

Belt driven fans offer the versatility of changing air capacities by changing the sheaves during or after installation. Both direct drive and belt drive features have easy to remove motor covers for simple inspection and maintenance. Extra low contour makes them inconspicuous from street level.

The Fiber-Aire® series fiberglass centrifugal power roof ventilators are designed for the exhaust of moisture-laden, corrosive, or chemically contaminated air frequently associated with aquariums, indoor swimming pools, laboratories, waste water treatment plants, etc.

Sizes and Capacities

- Direct drive sizes 7" to 18"
- Belt driven size 12" to 40"
- Airflow to 19,500 CFM
- Static pressures to 1¾" w.g.

Construction Features

- Molded fiberglass housings are virtually impossible to dent, crack, or break and resist weather, salt spray, and most chemicals. Fiberglass housings also absorb noise and vibration.
- Designed for applications requiring the exhaust of chemical fumes or hazardous matter suspended in the air.
- Easy-to-remove motor covers for easy inspection and maintenance.
- Fan wheels are polypropylene, backward inclined, as standard.
- All structural mild steel components in contact with airstream are epoxy coated for additional corrosion resistance.
- A ½" x ½" PVC coated bird screen is standard on all units to prevent entry of birds and debris.
- Factory mounted and wired disconnect switch is standard on all units, except with EXP motors.
- A conduit chase extending through the curb cap and into the motor compartment is provided as standard on all units for field supply conductors.
- 304 SS fan shaft on belt driven unit.

Accessories

- Gravity (PVC) and motor operated (aluminum) backdraft dampers
- Fiberglass roof curbs
- Stainless steel birdscreen

Maximum Fan RPM

MODEL NO.	MOTOR HP	MAX FAN RPM
12FA•B	1/4	1676
	1/3	1844
	1/2	2112
14FA•B	1/4	1468
	1/3	1616
	1/2	1850
18FA•B	1/4	905
	1/3	993
	1/2	1140
24FA•B	1/4	568
	1/3	625
	1/2	716
	3/4	819
	1	902
30FA•B	1/3	436
	1/2	500
	3/4	572
	1	630
	1½	721
	2	793

MODEL NO.	MOTOR HP	MAX FAN RPM
36FA•B	1/2	369
	3/4	422
	1	464
	1½	532
	2	585
40FA•B	3	670
	1/2	320
	3/4	366
	1	403
	1½	461
	2	508
	3	581
	5	689



Model FA – Direct Drive

MODEL NO.	HP	PEAK BHP	MTR RPM	CFM VERSUS STATIC PRESSURE								SOUND POWER REFERENCE 10 ⁻¹² WATTS								SONES AT 0" SP
				0"	1/8"	1/4"	3/8"	1/2"	5/8"	3/4"	1"	OCTAVE BAND CENTER FREQUENCIES								
												63	125	250	500	1000	2000	4000	8000	
7FA1	1/15	0.06	1550	147	127	103	23													14.6
7FA2	1/15	0.09	1550	435	340	245														9.1
9FA1	1/15	0.08	1550	535	467	402	313	245	80											13.8
10FA1	1/8	0.06	1140	595	445	295	155													9.3
10FA2	1/6	0.19	1725	900	800	700	605	510	380	295	100									14.9
12FA1	1/12	0.03	860	682	570	362						72	73	66	59	54	48	43	41	6.2
12FA2	1/8	0.07	1140	904	836	725	576	328				76	82	75	68	62	58	50	48	10.9
12FA3	1/4	0.27	1725	1368	1329	1281	1220	1146	1059	963	733	84	87	88	81	75	69	64	58	20.0
14FA1	1/12	0.05	860	1084	914	725	424					75	72	65	62	57	59	49	50	7.4
14FA2	1/8	0.11	1140	1437	1308	1180	1040	861	658			82	81	73	70	64	65	61	54	12.2
14FA3	1/2	0.40	1725	2175	2090	2004	1920	1835	1747	1656	1459	94	90	87	80	77	72	74	64	23.0
18FA1	1/4	0.21	860	2361	2158	1944	1708	1387	885			75	80	81	76	69	64	56	50	13.5
18FA2	1/2	0.49	1140	3129	2979	2822	2661	2318	2107	1526		79	85	88	85	76	74	65	59	21.0

- Performance shown is for installation Type A: free inlet, free outlet.
- The sound power level ratings shown are in decibels, referred to 10⁻¹² watts calculated per AMCA Standard 301. Values shown are for Lwi sound power levels for installation Type A: free inlet, free outlet. Ratings do not include the effects of duct end correction for inlet and outlet ducts.
- Performance ratings do not include the effects of appurtenances in the airstream.

Model FAB – Belt Driven

MODEL NO.	HP	PEAK BHP	FAN RPM	CFM VERSUS STATIC PRESSURE											SOUND POWER REFERENCE 10 ⁻¹² WATTS								SONES AT 0" SP
				0"	1/8"	1/4"	3/8"	1/2"	5/8"	3/4"	1"	1 1/4"	1 1/2"	1 3/4"	OCTAVE BAND CENTER FREQUENCIES								
															63	125	250	500	1000	2000	4000	8000	
12FA1B	1/4	0.12	1331	1055	1001	922	815	684	521												10.0		
12FA2B	1/4	0.16	1465	1162	1114	1049	962	856	733	583											11.5		
12FA3B	1/4	0.25	1676	1329	1298	1238	1174	1094	1002	900	644										19.4		
12FA4B	1/3	0.33	1844	1462	1426	1383	1330	1266	1192	1108	915	791	653								23.0		
12FA5B	1/2	0.50	2112	1675	1644	1609	1568	1520	1465	1403	1259	1094	898	575							29.0		
14FA1B	1/4	0.12	1166	1470	1344	1219	1083	933	735												12.8		
14FA2B	1/4	0.16	1283	1618	1503	1389	1271	1144	1002	821											14.9		
14FA3B	1/4	0.25	1468	1851	1750	1651	1551	1447	1336	1217	911	1230	870								18.5		
14FA4B	1/3	0.33	1616	2037	1946	1855	1766	1674	1577	1476	1254										22.0		
14FA5B	1/2	0.50	1850	2332	2253	2173	2095	2016	1936	1852	1678										27.0		
18FA1B	1/4	0.16	790	2169	1946	1710	1418	969													11.8		
18FA2B	1/4	0.25	905	2484	2292	2090	1875	1605	1230	373											14.6		
18FA3B	1/3	0.33	993	2726	2552	2369	2181	1972	1708	1359											17.2		
18FA4B	1/2	0.50	1140	3129	2979	2822	2661	2496	2318	2107	1526										21.0		
24FA1B	1/4	0.16	496	3341	2809	2132	981														6.6		
24FA2B	1/4	0.25	568	3825	3367	2842	2158	980													8.2		
24FA3B	1/3	0.33	625	4209	3794	3344	2795	2078													9.6		
24FA4B	1/2	0.50	716	4822	4461	4088	3666	3172	2562	1725											12.2		
24FA5B	3/4	0.75	819	5516	5201	4880	4542	4163	3732	3241	1827										15.5		
24FA6B	1	1.0	902	6075	5791	5499	5204	4884	4528	4139	3189	1671									18.8		
30FA1B	1/3	0.33	436	5703	4962	4135	3003														8.8		
30FA2B	1/2	0.50	500	6540	5900	5219	4430	3372	1063												11.4		
30FA3B	3/4	0.75	572	7482	6926	6345	5725	5003	4103	2946											14.3		
30FA4B	1	1.0	630	8240	7738	7217	6673	6087	5408	4577											16.4		
30FA5B	1 1/2	1.5	721	9431	8993	8545	8082	7603	7095	6528	5128	3035									21.0		
30FA6B	2	2.0	793	10372	9974	9570	9155	8729	8290	7828	6758	5397	3501								24.0		
36FA1B	1/2	0.50	369	8644	7438	6135	4579														9.4		
36FA2B	3/4	0.75	422	9885	8839	7738	6541	5097	2348												12.1		
36FA3B	1	1.0	464	10869	9922	8937	7893	6751	5350	2853											14.8		
36FA4B	1 1/2	1.5	532	12462	11643	10792	9916	8996	8013	6893	2529										18.1		
36FA5B	2	2.0	585	13704	12964	12194	11413	10599	9753	8854	6659										21.0		
36FA6B	3	3.0	670	15695	15056	14386	13708	13022	12317	11587	10030	8191	5346								27.0		
40FA1B	1/2	0.50	320	9061	7681	6024	3256														6.7		
40FA2B	3/4	0.75	366	10363	9157	7878	6129	3433													8.6		
40FA3B	1	1.0	403	11411	10315	9200	7863	6009	2995												10.6		
40FA4B	1 1/2	1.5	461	13053	12095	11136	10116	8893	7302	5303											13.5		
40FA5B	2	2.0	508	14384	13516	12648	11760	10788	9619	8159	3505										15.8		
40FA6B	3	3.0	581	16451	15693	14932	14173	13392	12544	11580	9125	5655									18.7		
40FA7B	5	5.0	689	19509	18873	18227	17589	16949	16301	15623	14114	12224	9907	7200							26.0		

- Performance shown is for installation Type A: free inlet, free outlet.
- The sound power level ratings shown are in decibels, referred to 10⁻¹² watts calculated per AMCA Standard 301. Values shown are for Lwi sound power levels for installation Type A: free inlet, free outlet. Ratings do not include the effects of duct end correction for inlet and outlet ducts.
- Power rating (BHP) does not include drive losses.
- Performance ratings do not include the effects of appurtenances in the airstream.

Model FA - Direct Drive

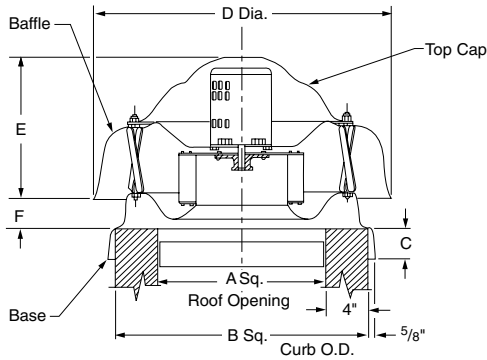

Model FAB - Belt Drive

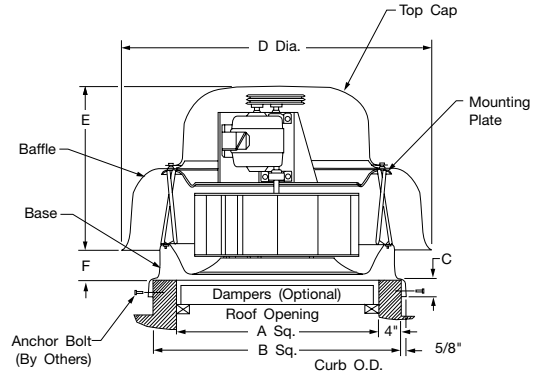

Model FA - Direct Drive

MODEL NO.	HP	RPM	WEIGHT (LBS.)	DIMENSIONS (INCHES)						BACKDRAFT DAMPER
				A	B	C	D	E	F	
7FA1	1/15	1550	23	12	20	2	21 ³ / ₈	10	3 ³ / ₁₆	10 x 10
7FA2	1/15	1550	20	12	20	2	21 ³ / ₈	10	2 ¹¹ / ₁₆	10 x 10
9FA1	1/15	1550	24	12	20	2	21 ³ / ₈	10	2 ¹ / ₂	10 x 10
10FA1	1/8	1160	43	16	24	2 ³ / ₄	28 ¹ / ₄	15 ¹ / ₂	3 ¹ / ₄	14 x 14
10FA2	1/6	1750	39	16	24	2 ³ / ₄	28 ¹ / ₄	15 ¹ / ₂	3 ¹ / ₄	14 x 14
12FA1	1/12	860	43	16	24	2 ³ / ₄	28 ¹ / ₄	15 ¹ / ₂	2 ¹ / ₈	14 x 14
12FA2	1/8	1160	45	16	24	2 ³ / ₄	28 ¹ / ₄	15 ¹ / ₂	2 ¹ / ₈	14 x 14
12FA3	1/4	1750	49	16	24	2 ³ / ₄	28 ¹ / ₄	15 ¹ / ₂	2 ¹ / ₈	14 x 14
14FA1	1/12	860	51	16	24	2 ³ / ₄	28 ¹ / ₄	15 ¹ / ₂	4 ⁵ / ₈	14 x 14
14FA2	1/8	1160	50	16	24	2 ³ / ₄	28 ¹ / ₄	15 ¹ / ₂	4 ⁵ / ₈	14 x 14
14FA3	1/2	1750	49	16	24	2 ³ / ₄	28 ¹ / ₄	15 ¹ / ₂	4 ⁵ / ₈	14 x 14
18FA1	1/4	860	78	20	28	3 ¹ / ₈	35 ¹ / ₈	21 ³ / ₄	4 ³ / ₄	18 x 18
18FA2	1/2	1160	83	20	28	3 ¹ / ₈	35 ¹ / ₈	21 ³ / ₄	4 ³ / ₄	18 x 18

D-3200-1

Model FAB - Belt Driven

MODEL NO.	HP	WEIGHT (LBS.)	DIMENSIONS (INCHES)						BACKDRAFT DAMPER	
			A	B	C	D	E	F		
12FA1B	1/4	42								
12FA2B	1/4	42								
12FA3B	1/4	42	16	24	2 ³ / ₄	28 ¹ / ₄	23 ³ / ₈	2 ¹ / ₈		14 x 14
12FA4B	1/3	44								
12FA5B	1/2	49								
14FA1B	1/4	44								
14FA2B	1/4	44								
14FA3B	1/4	47	16	24	2 ³ / ₄	28 ¹ / ₄	23 ³ / ₈	4 ⁵ / ₈		14 x 14
14FA4B	1/3	46								
14FA5B	1/2	51								
18FA1B	1/4	69								
18FA2B	1/4	70								
18FA3B	1/3	70	20	28	3 ¹ / ₈	35 ¹ / ₈	25 ³ / ₄	4 ³ / ₄		18 x 18
18FA4B	1/2	76								
24FA1B	1/4	142								
24FA2B	1/4	144								
24FA3B	1/3	143	28	36	3	42 ¹³ / ₁₆	26	5 ¹ / ₄		24 x 24
24FA4B	1/2	148								
24FA5B	3/4	154								
24FA6B	1	176								
30FA1B	1/3	188								
30FA2B	1/2	193								
30FA3B	3/4	202	36	44	3	53 ⁵ / ₁₆	31 ¹ / ₂	6		30 x 30
30FA4B	1	210								
30FA5B	1 ¹ / ₂	235								
30FA6B	2	236								
36FA1B	1/2	258								
36FA2B	3/4	261								
36FA3B	1	285	44	52	3	62 ¹ / ₂	34 ³ / ₄	8 ¹ / ₂		36 x 36
36FA4B	1 ¹ / ₂	296								
36FA5B	2	297								
36FA6B	3	329								
40FA1B	1/2	353								
40FA2B	3/4	356								
40FA3B	1	370	44	52	3	62 ¹ / ₂	34 ³ / ₄	8 ¹ / ₂		36 x 36
40FA4B	1 ¹ / ₂	379								
40FA5B	2	380								
40FA6B	3	405								
40FA7B	5	454								

D-3200-2

FIBERGLASS ROOF EXHAUSTERS

Whirlout® WA/WAB

Application

The Whirlout® Series WA/WAB fiberglass up-blast centrifugal roof exhausters are especially designed for applications requiring the exhaust of chemical fumes or cooking grease where the removal of exhaust away from the roof line is required.

Fiberglass roof exhausters are available as direct or adjustable capacity belt drive. Each configuration features an isolated motor and drive chamber with a neoprene shaft seal to protect motor and drive components from fumes or hazardous matter suspended in the air. The up-blast design makes it ideal for use with ducts, hoods or canopies over interior work areas. Basket type supports eliminate internal air shocks, reduce vibration and increase efficiency.

The fiberglass housing of the unit has excellent resistance to a wide range of chemicals and fumes. The corrosion resistant, backward inclined wheel provides quiet and efficient operation.

Whirlout® Series fiberglass upblast centrifugal roof exhausters are also used in natatoriums, aquariums, indoor swimming pools, laboratories, waste water treatment plants, and any other area, where corrosive fumes present a problem.

Sizes and Capacities

- Direct drive sizes 7" to 18"
- Belt driven sizes 14" to 40"
- Airflow to 21,500 CFM
- Static pressures to 2" w.g.

Construction Features

- Molded fiberglass housings are virtually impossible to dent, crack, or break, and resist weather, salt spray, and most chemicals. Fiberglass housings also absorb noise and vibration.
- Designed for applications requiring the exhaust of chemical fumes or contaminated air up and away from the roof.
- Ideal for use with ducts, hoods, or canopies over interior work areas.
- Fan wheels are polypropylene, backward inclined, as standard.
- All structural mild steel components in contact with airstream are epoxy coated for additional corrosion resistance.
- A neoprene shaft seal is standard on all belt drive units to protect motor and drives from fumes or hazardous matter suspended in the air.



- A 1/2" x 1/2" PVC coated bird screen is standard on all units to prevent entry of birds and debris.
- Factory mounted and wired disconnect switch is standard on all units, except with EXP motors.
- A conduit chase extending through the curb cap and into the motor compartment is provided as standard on all units for field wiring.
- 304 SS fan shaft on belt driven unit.

Accessories

- Gravity (PVC) and motorized (aluminum) backdraft dampers
- Fiberglass roof curbs
- Stainless steel bird screen

Maximum Fan RPM

MODEL NO.	MOTOR HP	MAX FAN RPM
14WA*B	1/4	1420
	1/3	1560
	1/2	1786
18WA*B	1/4	898
	1/3	988
	1/2	1131
24WA*B	1/4	559
	1/3	615
	1/2	704
	3/4	806
30WA*B	1	887
	1/3	434
	1/2	497
	3/4	569
	1	627
	1 1/2	717
2	790	

MODEL NO.	MOTOR HP	MAX FAN RPM
36WA*B	1/2	363
	3/4	416
	1	458
	1 1/2	524
	2	577
	3	660
40WA*B	5	782
	1/2	312
	3/4	357
	1	393
	1 1/2	450
	2	495
	3	567
5	672	
7 1/2	763	

WA/WAB

Model WA – Direct Drive

MODEL NO.	HP	PEAK BHP	MTR RPM	CFM VERSUS STATIC PRESSURE									SOUND POWER REFERENCE 10 ⁻¹² WATTS								SONES AT 0" SP
				0"	1/8"	1/4"	3/8"	1/2"	5/8"	3/4"	1"	OCTAVE BAND CENTER FREQUENCIES									
												63	125	250	500	1000	2000	4000	8000		
7WA2	1/15	0.04	1550	370	355	290	140														2.5
10WA1	1/12	0.02	860	600	465	200															2.2
10WA2	1/8	0.05	1140	800	700	580	420	50													3.7
10WA3	1/6	0.18	1725	1210	1145	1080	1005	930	845	740	370										7.2
12WA1	1/12	0.03	860	648	498	263						74	69	65	63	59	58	50	48		7.1
12WA2	1/8	0.07	1140	859	751	628	464					82	77	73	71	67	64	60	54	11.3	
12WA3	1/4	0.26	1725	1300	1229	1157	1082	1002	911	808	536	93	89	84	81	78	74	73	65	23.0	
14WA1	1/12	0.06	860	1060	883	658	298					73	72	68	64	60	60	48	50	7.7	
14WA2	1/8	0.13	1140	1405	1276	1135	970	768	501			79	81	76	72	67	67	60	54	12.6	
14WA3	1/2	0.45	1725	2127	2041	1955	1867	1774	1675	1568	1326	88	88	87	83	79	75	75	63	23.0	
18WA1	1/4	0.17	860	2011	1796	1566	1288	926				81	79	76	71	66	63	56	53	11.6	
18WA2	1/2	0.39	1140	2665	2505	2340	2170	1982	1770	1527	900	87	87	84	80	74	71	65	60	18.9	

1. Performance shown is for installation Type A: free inlet, free outlet.
2. The sound power level ratings shown are in decibels, referred to 10⁻¹² watts calculated per AMCA Standard 301. Values shown are for Lwi sound power levels for installation Type A: free inlet, free outlet. Ratings do not include the effects of duct end correction for inlet and outlet ducts.
3. Performance ratings do not include the effects of appurtenances in the airstream.

Model WAB – Belt Driven

MODEL NO.	HP	PEAK BHP	FAN RPM	CFM VERSUS STATIC PRESSURE											SOUND POWER REFERENCE 10 ⁻¹² WATTS								SONES AT 0" SP	
				0"	1/8"	1/4"	3/8"	1/2"	5/8"	3/4"	1"	1 1/4"	1 1/2"	1 3/4"	2"	OCTAVE BAND CENTER FREQUENCIES								
																63	125	250	500	1000	2000	4000		8000
14WA1B	1/4	0.12	1125	1387	1255	1112	943	732	442													11.9		
14WA2B	1/4	0.16	1238	1526	1406	1281	1137	973	772	507												14.0		
14WA3B	1/4	0.25	1418	1748	1644	1539	1423	1299	1155	989	538											17.6		
14WA4B	1/3	0.33	1560	1923	1832	1733	1632	1522	1406	1276	962	480										20.0		
14WA5B	1/2	0.50	1786	2201	2118	2037	1952	1864	1768	1664	1441	1185	850	205								24.0		
18WA1B	1/4	0.16	784	2084	1822	1521	1130	488														10.0		
18WA2B	1/4	0.25	898	2387	2160	1915	1626	1268	753													12.9		
18WA3B	1/3	0.33	988	2626	2420	2205	1964	1678	1334	858												15.4		
18WA4B	1/2	0.50	1131	3007	2827	2643	2448	2231	1987	1705	911											18.7		
24WA1B	1/4	0.16	488	3167	2603	1811																8.5		
24WA2B	1/4	0.25	559	3628	3146	2562	1735															10.7		
24WA3B	1/3	0.33	615	3992	3557	3067	2420	1567														12.9		
24WA4B	1/2	0.50	704	4569	4195	3791	3320	2720	1992													16.8		
24WA5B	3/4	0.75	806	5231	4910	4563	4195	3768	3253	2656												21.0		
24WA6B	1	1.00	887	5757	5469	5155	4834	4484	4079	3607	2465											25.0		
30WA1B	1/3	0.33	434	5284	4557	3690	2419															10.0		
30WA2B	1/2	0.50	497	6051	5424	4730	3886	2666														13.0		
30WA3B	3/4	0.75	569	6927	6384	5807	5158	4389	3377													16.5		
30WA4B	1	1.00	627	7634	7143	6629	6074	5451	4723	3805												19.0		
30WA5B	1 1/2	1.50	717	8729	8302	7861	7399	6908	6366	5763	4201											23.0		
30WA6B	2	2.00	790	9618	9231	8835	8427	7999	7544	7048	5914	4343										28.0		
36WA1B	1/2	0.50	363	8226	7108	5681	3663															10.0		
36WA2B	3/4	0.75	416	9428	8477	7347	5944	4006														13.1		
36WA3B	1	1.00	458	10379	9528	8551	7403	6001	4136													15.5		
36WA4B	1 1/2	1.50	524	11875	11143	10333	9426	8387	7181	5715												19.5		
36WA5B	2	2.00	577	13076	12417	11702	10921	10052	9082	7979	5087											23.0		
36WA6B	3	3.00	660	14957	14388	13780	13131	12433	11685	10867	8974	6544										28.0		
36WA7B	5	5.00	782	17722	17230	16761	16235	15688	15100	14432	13157	11650	9900	7899	4032							39.0		
40WA1B	1/2	0.50	312	8795	7263	5263	1099															10.5		
40WA2B	3/4	0.75	357	10064	8756	7170	5189															13.2		
40WA3B	1	1.00	393	11078	9899	8555	6941	4778														15.2		
40WA4B	1 1/2	1.50	450	12685	11657	10569	9286	7839	6065	2894												18.9		
40WA5B	2	2.00	495	13954	13019	12062	10983	9746	8394	6759												22.0		
40WA6B	3	3.00	567	15983	15164	14351	13480	12512	11438	10302	7517											28.0		
40WA7B	5	5.00	672	18943	18249	17567	16871	16139	15354	14496	12624	10537	7607	2000								37.0		
40WA8B	7 1/2	7.50	763	21508	20922	20300	19689	19092	18430	17748	16235	14586	12776	10788	7690							44.0		

1. Performance shown is for installation Type A: free inlet, free outlet.
2. The sound power level ratings shown are in decibels, referred to 10⁻¹² watts calculated per AMCA Standard 301. Values shown are for Lwi sound power levels for installation Type A: free inlet, free outlet. Ratings do not include the effects of duct end correction for inlet and outlet ducts.
3. Power rating (BHP) does not include drive losses.
4. Performance ratings do not include the effects of appurtenances in the airstream.

WA/WAB

Model WA - Direct Drive

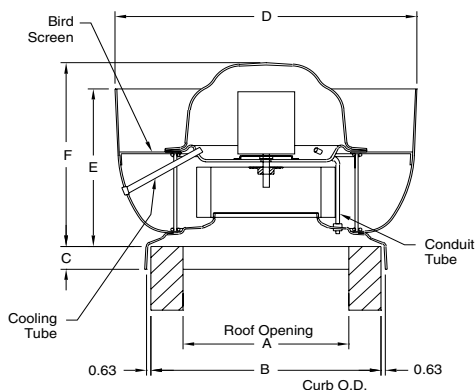

Model WAB - Belt Driven

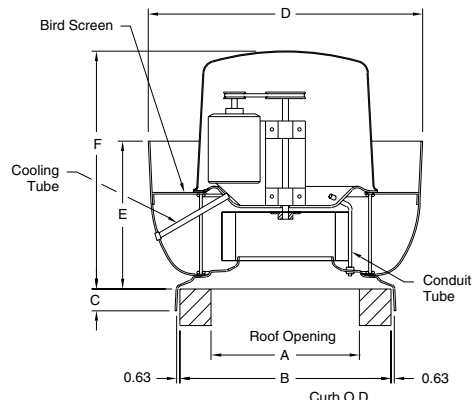

Model WA - Direct Drive

MODEL NO.	HP	RPM	WEIGHT (LBS.)	DIMENSIONS (INCHES)						BACKDRAFT DAMPER
				A	B	C	D	E	F	
7WA2	1/15	1550	18	8	16	2	17 ¹ / ₄	8	11 ¹¹ / ₁₆	6 x 6
10WA1	1/12	860	50	12	20	3	25 ¹ / ₄	12 ¹ / ₈	18 ⁵ / ₈	10 x 10
10WA2	1/8	1160	43							
10WA3	1/6	1750	44							
12WA1	1/12	860	50	12	20	3	25 ¹ / ₄	12 ¹ / ₈	19 ³ / ₈	10 x 10
12WA2	1/8	1160	43							
12WA3	1/4	1750	46							
14WA1	1/12	860	67	16	24	3	28 ⁷ / ₈	17 ¹ / ₂	28 ¹ / ₁₆	14 x 14
14WA2	1/8	1160	67							
14WA3	1/2	1750	73							
18WA1	1/4	860	118	20	28	3	36 ³ / ₄	25	32 ³ / ₈	18 x 18
18WA2	1/2	1160	130							

D-3300-1C

Model WAB - Belt Driven

MODEL NO.	HP	WEIGHT (LBS.)	DIMENSIONS (INCHES)						BACKDRAFT DAMPER
			A	B	C	D	E	F	
14WA1B	1/4	72	16	24	3	28 ⁷ / ₈	17 ¹ / ₂	28 ¹ / ₁₆	14 x 14
14WA2B	1/4	73							
14WA3B	1/4	75							
14WA4B	1/3	74							
14WA5B	1/2	76							
18WA1B	1/4	123	20	28	3	36 ³ / ₄	25	32 ³ / ₈	18 x 18
18WA2B	1/4	125							
18WA3B	1/3	129							
18WA4B	1/2	133							
24WA1B	1/4	185	28	36	3	45 ³ / ₄	31	34 ¹ / ₁₆	24 x 24
24WA2B	1/4	187							
24WA3B	1/3	192							
24WA4B	1/2	195							
24WA5B	3/4	202							
24WA6B	1	205							
30WA1B	1/3	265	36	44	3	59	34 ¹ / ₂	39 ⁵ / ₈	30 x 30
30WA2B	1/2	269							
30WA3B	3/4	287							
30WA4B	1	291							
30WA5B	1 ¹ / ₂	295							
30WA6B	2	307							
36WA1B	1/2	572	44	52	3	69 ¹ / ₂	45	46 ¹ / ₁₆	36 x 36
36WA2B	3/4	591							
36WA3B	1	595							
36WA4B	1 ¹ / ₂	599							
36WA5B	2	611							
36WA6B	3	615							
36WA7B	5	625							
40WA1B	1/2	632							
40WA2B	3/4	658							
40WA3B	1	675							
40WA4B	1 ¹ / ₂	671							
40WA5B	2	677							
40WA6B	3	681							
40WA7B	5	730							
40WA8B	7 ¹ / ₂	750							

D-3300-2C

FIBERGLASS WALL EXHAUSTERS

Fiber-Aire® SA

Application

The Fiber-Aire® Series SA fiberglass wall ventilators are ideal for applications where exhausting from the roof is impractical or impossible. Featuring the same high-volume, polypropylene backward inclined wheel as the standard Fiber-Aire®, the wall Fiber-Aire® effectively and efficiently pulls hazardous fumes, dust, or corrosive gases from the building interior and exhausts them away from the building and the exterior wall.

The wall Fiber-Aire® Series features the same virtually indestructible fiberglass housing, which is completely weatherproof and isolates the motor from the airstream. Its quiet operation allows the wall Fiber-Aire® to be placed in close proximity to work areas for maximum exhaust benefits and worker comfort. The exterior design and molded-in beige color blend in with most brick and exterior wall colors without detracting from overall building appearance. Wall shutters are available as accessories.

These fiberglass centrifugal ventilators are used in natatoriums, aquariums, indoor swimming pools, laboratories, and waste water treatment plants.

Sizes and Capacities

- Direct drive sizes 7" to 14"
- Airflow to 2,230 CFM
- Static pressures to 1" w.g.

Construction Features

- Molded fiberglass housings are virtually impossible to dent, crack or break and resist weather, salt spray, and most chemicals. Fiberglass housings also absorb noise and vibration.



- Designed for applications requiring the exhaust of chemical fumes or hazardous matter suspended in the air.
- Fan wheels are polypropylene, backward inclined, as standard.
- All structural mild steel components in contact with airstream are epoxy coated for additional corrosion resistance.
- A PVC coated bird screen is standard on all units.
- Factory mounted and wired disconnect switch is standard on all units, except with EXP motors.
- A conduit chase is provided as standard to allow field electrical wiring from inside the building, through the fiberglass inlet venturi, and to the disconnect switch.

Accessories

- Gravity (PVC) and motorized (aluminum) backdraft dampers
- Stainless steel bird screen

Model SA – Direct Drive

MODEL NO.	HP	PEAK BHP	FAN RPM	CFM VERSUS STATIC PRESSURE								SOUND POWER REFERENCE 10 ⁻¹² WATTS OCTAVE BAND CENTER FREQUENCIES						SONES AT 0" SP		
				0"	1/8"	1/4"	3/8"	1/2"	5/8"	3/4"	1"	63	125	250	500	1000	2000		4000	6000
				7SA1	1/15	0.02	1550	235	180	120										
7SA2	1/15	0.03	1550	360	290	190													6.1	
12SA1	1/12	0.03	860	652	502	296						71	60	59	59	56	56	45	48	5.7
12SA2	1/8	0.06	1140	864	756	634	497					78	71	65	65	65	62	56	52	8.9
12SA3	1/4	0.20	1725	1308	1238	1165	1090	1009	923	837	603	87	86	75	74	74	71	71	60	17.6
14SA1	1/12	0.06	860	1112	960	754	438					77	74	66	65	60	59	48	50	7.9
14SA2	1/8	0.15	1140	1474	1365	1241	1090	906	668	295		82	85	72	72	68	66	58	54	14.0
14SA3	1/2	0.51	1725	2230	2161	2087	2010	1929	1840	1742	1517	95	91	89	87	80	75	74	63	27.0

1. Performance shown is for installation Type A: free inlet, free outlet.
2. The sound power level ratings shown are in decibels, referred to 10⁻¹² watts calculated per AMCA Standard 301. Values shown are for Lwi sound power levels for installation Type A: free inlet, free outlet. Ratings do not include the effects of duct end correction for inlet and outlet ducts.
3. Performance ratings do not include the effects of appurtenances in the airstream.

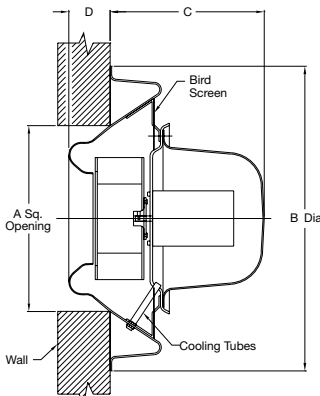

Model SA - Direct Drive

MODEL NO.	HP	FAN RPM	DIMENSIONS (INCHES)				NET WT. (LBS.)	BACKDRAFT DAMPER*
			A	B	C	D		
7SA1	1/15	1550	10	19½	9¾	1½	15	
7SA2	1/15	1550	10	19½	9¾	1½	15	10 x 10
12SA1	1/12	860	17	28	15	3½	45	
12SA2	1/8	1160	17	28	15	3½	43	17 x 17
12SA3	1/4	1750	17	28	15	3½	45	
14SA1	1/12	860	24	36½	18½	5	78	
14SA2	1/8	1160	24	36½	18½	5	78	24 x 24
14SA3	1/2	1750	24	36½	18½	5	80	

* PVC damper to have 7/8" flanges. Aluminum damper to have 1½" flanges.

D-3400

Hid-N-Aire® HA/HAB

Application

The Hid-N-Aire®, Model HA/HAB, fiberglass wall mount ventilators provide high performance ventilation without distracting from the architectural lines of a building's exterior. Only the aluminum fixed louver, which fits flush with the building's wall, is visible from the outside of the building. From the interior, the unit presents a clean, molded fiberglass venturi. All fiberglass components come in the standard beige color.

The Hid-N-Aire® fiberglass centrifugal wall ventilators are designed to mount compactly within an exterior wall and satisfy general building exhaust requirements.

Sizes and Capacities

- Direct drive sizes 7" to 18"
- Belt driven sizes 12" to 30"
- Airflow to 9,800 CFM
- Static pressures to 1" w.g.

Construction Features

- Rugged molded fiberglass inlet venturi.
- Rubber isolator motor mounts absorb vibration for quietness.
- Fan wheels are polypropylene, backward inclined, as standard.
- All structural mild steel components in contact with airstream are epoxy coated for additional corrosion resistance.
- Extruded fixed aluminum louver fits flush with the building's wall and is visible only from the exterior.
- Built-in PVC bird screen and fabric backdraft dampers within aluminum louver.
- Simple to install and maintain.
- Motor is prewired with plug and cord assembly (disconnect switch) and provided with a plug-in electrical receptacle mounted inside the motor housing for ease of maintenance and service.
- 304 SS fan shaft on belt driven unit.

Accessories

- An attractive grille is available for attachment to fiberglass venturi when ductwork to HA/HAB is not present.
- Duct adapter kit for use when HA/HAB is used as an inline centrifugal unit.
- Companion angles.



Static Pressure Drop Calculation

Performances shown for fiberglass wall ventilators are the capacities without the exterior wall louver. The following tables give the gross louver areas and the static pressure drop. An example is also shown to help you determine the correct size unit for a specific application.

Example:

Required 825 CFM @ 1/8" S.P. (.125) quiet duty.

1. Select a direct drive unit from the performance data on page 3 with a slightly higher capacity such as 14HA-1 (863 CFM @ 1/8" S.P.)
2. Divide the CFM by the gross louver area (see Table 1) to obtain gross velocity: $863 \div 3.84 = 225$ FPM
3. From Table 2, the static pressure drop is slightly more than .018 (approximately .023).
4. Add the specified static pressure to the static pressure drop through the louver: $.125 + .023 = .148$ in. w.g. total static pressure
5. Checking the capacity table on page 3, we now see that because the static pressure has increased slightly, the capacity has decreased slightly. The 14HA-1 unit will deliver 825 CFM @ .148 static pressure through the exterior flush-mounted louver.

Table 1.

SIZE	GROSS AREA OF LOUVER
7	1.13 sq. ft.
10, 12	2.92 sq. ft.
14	3.84 sq. ft.
18	4.69 sq. ft.
24	9.52 sq. ft.
30	14.71 sq. ft.

Table 2. Static Pressure Drop For Various Velocities

GROSS VEL. (FPM)	100	200	300	400	500	600	700
S.P. DROP (IN. W.G.)	.005	.018	.041	.073	.114	.164	.224

HA/HAB

Model HA – Direct Drive

MODEL NO.	HP	PEAK BHP	FAN RPM	CFM VERSUS STATIC PRESSURE								SOUND POWER REFERENCE 10 ⁻¹² WATTS								SONES AT 0" SP	
				0"	1/8"	1/4"	3/8"	1/2"	5/8"	3/4"	1"	OCTAVE BAND CENTER FREQUENCIES									
												63	125	250	500	1000	2000	4000	8000		
7HA1	1/15	0.02	1550	180	160	130	75	—	—	—	—	—	—	—	—	—	—	—	—	—	3.4
7HA2	1/15	0.03	1550	350	325	280	135	—	—	—	—	—	—	—	—	—	—	—	—	—	3.2
10HA1	1/8	0.05	1140	700	595	455	255	—	—	—	—	—	—	—	—	—	—	—	—	—	4.5
10HA2	1/6	0.18	1725	1060	990	910	830	745	645	520	110	—	—	—	—	—	—	—	—	—	9.0
12HA1	1/12	0.03	860	617	463	222	—	—	—	—	—	73	63	57	58	58	60	45	49	—	6.5
12HA2	1/8	0.07	1140	819	711	579	412	—	—	—	—	79	69	63	64	64	66	51	55	—	9.5
12HA3	1/4	0.24	1725	1239	1170	1098	1018	930	834	728	456	88	78	72	73	73	75	60	64	—	16.6
14HA1	1/12	0.05	860	1038	863	631	—	—	—	—	—	70	68	65	62	63	63	54	50	—	8.2
14HA2	1/8	0.11	1140	1376	1250	1108	938	729	400	—	—	76	74	71	68	69	69	60	56	—	11.9
14HA3	1/2	0.40	1725	2082	2001	1916	1828	1733	1633	1523	1271	85	83	80	77	78	78	69	65	—	21.0
18HA1	1/4	0.18	860	1982	1763	1510	1211	817	—	—	—	74	74	72	68	77	68	61	55	—	13.7
18HA2	1/2	0.43	1140	2627	2467	2295	2107	1898	1671	1416	—	80	80	78	74	83	74	67	61	—	19.7

1. Performance shown is for installation Type A: free inlet, free outlet.
2. The sound ratings shown are loudness values in fan sones at 5 ft. in a hemispherical free field calculated per AMCA Standard 301-90. Values shown are for installation Type A: free inlet fan sone levels.
3. Performance ratings do not include the effects of appurtenances in the airstream.

Model HAB – Belt Driven

MODEL NO.	HP	PEAK BHP	FAN RPM	CFM VERSUS STATIC PRESSURE								SOUND POWER REFERENCE 10 ⁻¹² WATTS								SONES AT 0" SP	
				0"	1/8"	1/4"	3/8"	1/2"	5/8"	3/4"	1"	OCTAVE BAND CENTER FREQUENCIES									
												63	125	250	500	1000	2000	4000	8000		
12HA1B	1/4	0.12	1380	991	904	806	692	559	390	—	—	84	74	68	69	71	56	60	—	12.9	
12HA2B	1/4	0.16	1518	1090	1012	926	829	720	594	439	480	86	76	70	71	73	58	62	—	14.7	
12HA3B	1/4	0.25	1738	1248	1180	1108	1030	943	848	743	—	89	79	73	74	76	61	65	—	17.6	
14HA1B	1/4	0.12	1165	1406	1283	1145	982	784	508	—	—	77	75	72	69	70	70	61	57	—	12.6
14HA2B	1/4	0.16	1283	1549	1438	1317	1180	1021	832	581	—	79	77	74	71	72	72	63	59	—	14.2
14HA3B	1/4	0.25	1468	1772	1676	1573	1463	1342	1203	1048	620	82	80	77	74	75	75	66	62	—	17.1
14HA4B	1/3	0.33	1615	1950	1863	1771	1675	1571	1457	1331	1036	84	82	79	76	77	77	68	64	—	19.3
14HA5B	1/2	0.50	1849	2232	2157	2078	1997	1911	1821	1725	1508	87	85	82	79	80	80	71	67	—	23.0
18HA1B	1/4	0.16	826	1903	1675	1405	1081	595	—	—	—	73	73	71	67	76	67	60	54	—	12.9
18HA2B	1/4	0.25	945	2178	1981	1761	1507	1213	817	—	—	76	76	74	70	79	70	63	57	—	15.5
18HA3B	1/3	0.33	1040	2397	2220	2027	1810	1565	1288	921	—	78	78	76	72	81	72	65	59	—	17.5
18HA4B	1/2	0.50	1191	2745	2592	2429	2252	2058	1848	1617	1003	81	81	79	75	84	75	68	62	—	21.0
18HA5B	3/4	0.75	1363	3141	3009	2869	2722	2567	2397	2218	1821	84	84	82	78	87	78	71	65	—	25.0
24HA1B	1/4	0.25	575	3418	2953	2398	1656	—	—	—	—	75	77	74	71	68	67	62	57	—	11.9
24HA2B	1/3	0.33	633	3763	3345	2871	2287	1505	—	—	—	77	79	76	73	70	69	64	59	—	13.5
24HA3B	1/2	0.	725	4310	3949	3557	3111	2579	1926	700	—	80	82	79	76	73	72	67	62	—	16.3
24HA4B	3/4	0.75	830	4934	4621	4291	3934	3535	3076	2544	—	83	85	82	79	76	75	70	65	—	19.6
24HA5B	1	1.00	913	5427	5143	4849	4537	4198	3825	3409	2375	85	87	84	81	78	77	72	67	—	22.0
30HA1B	1/3	0.33	436	5399	4594	3611	2177	—	—	—	—	80	78	74	70	65	59	54	50	—	10.1
30HA2B	1/2	0.50	500	6192	5503	4724	3744	2399	—	—	—	83	78	77	73	68	62	57	53	—	12.2
30HA3B	3/4	0.75	572	7084	6487	5841	5113	4206	3077	—	—	86	81	80	76	71	65	60	56	—	14.7
30HA4B	1	1.00	630	7802	7264	6689	6068	5358	4498	3462	—	88	83	82	78	73	67	62	58	—	16.7
30HA5B	1 1/2	1.50	721	8929	8461	7973	7457	6906	6292	5587	3823	91	86	85	81	76	70	65	61	—	20.0
30HA6B	2	2.00	793	9820	9395	8959	8501	8021	7511	6951	5601	93	88	87	83	78	72	67	63	—	23.0

1. Performance shown is for installation Type A: free inlet, free outlet.
2. The sound ratings shown are loudness values in fan sones at 5 ft. in a hemispherical free field calculated per AMCA Standard 301-90. Values shown are for installation Type A: free inlet fan sone levels.
3. Power rating (BHP) does not include drive losses.
4. Performance ratings do not include the effects of appurtenances in the airstream.

HA/HAB

Model HA - Direct Drive

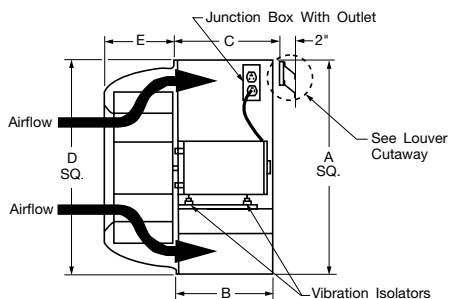

Model HAB - Belt Drive

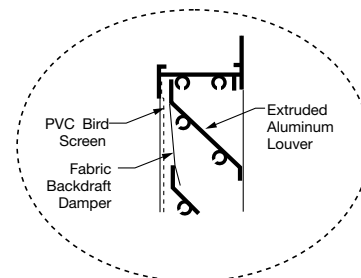
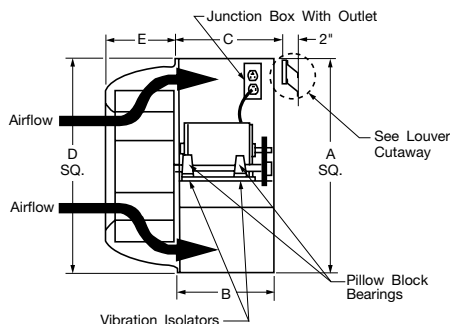

Louver Cutaway

Model HA - Direct Drive

MODEL NO.	HP	RPM	WEIGHT (LBS.)	DIMENSIONS (INCHES)					
				A SQ.	B	C MAX.		D SQ.	E
						STD. MOTOR	SPECIAL MOTOR		
7HA1	1/15	1550	30						
7HA2	1/15	1550	30	12 ³ / ₄	6 ¹ / ₈	6 ¹ / ₂	NA	13	3 ⁷ / ₈
10HA1	1/8	1160	70	20 ¹ / ₂	11 ³ / ₄	12 ¹ / ₈	13 ³ / ₄	20 ³ / ₄	6
10HA2	1/6	1750	75	20 ¹ / ₂	11 ³ / ₄	12 ¹ / ₈	13 ³ / ₄	20 ³ / ₄	6
12HA1	1/12	860	75	20 ¹ / ₂	11 ³ / ₄	12 ¹ / ₈	13 ³ / ₄	20 ³ / ₄	6
12HA2	1/8	1140	80	20 ¹ / ₂	11 ³ / ₄	12 ¹ / ₈	13 ³ / ₄	20 ³ / ₄	6
12HA3	1/4	1750	75	20 ¹ / ₂	11 ³ / ₄	12 ¹ / ₈	13 ³ / ₄	20 ³ / ₄	6
14HA1	1/12	860	90	23 ¹ / ₂	13	13 ³ / ₈	14 ¹ / ₄	23 ³ / ₄	7 ⁷ / ₈
14HA2	1/8	1160	90	23 ¹ / ₂	13	13 ³ / ₈	14 ¹ / ₄	23 ³ / ₄	7 ⁷ / ₈
14HA3	1/2	1750	105	23 ¹ / ₂	13	13 ³ / ₈	14 ¹ / ₄	23 ³ / ₄	7 ⁷ / ₈
18HA1	1/4	860	115	26	14	14 ³ / ₈	14 ³ / ₄	26 ¹ / ₄	8 ³ / ₄
18HA2	1/2	1160	115	26	14	14 ³ / ₈	14 ³ / ₄	26 ¹ / ₄	8 ³ / ₄

D-3100-1B

Dimension 'A' is the outside of the housing and the louver. Dimension 'D' is the outside of the trim angle.

Model HAB - Belt Driven

MODEL NO.	HP	WEIGHT (LBS.)	DIMENSIONS (INCHES)					
			A SQ.	B	C MAX.		D SQ.	E
					STD. MOTOR	SPECIAL MOTOR		
12HA1B	1/4	75						
12HA2B	1/4	80	20 ¹ / ₂	11 ³ / ₄	12 ¹ / ₈	16 ¹ / ₈	20 ³ / ₄	6
12HA3B	1/4	80	20 ¹ / ₂	11 ³ / ₄	12 ¹ / ₈	16 ¹ / ₈	20 ³ / ₄	6
14HA1B	1/4	90						
14HA2B	1/4	90	23 ¹ / ₂	13	13 ³ / ₈	18 ³ / ₈	23 ³ / ₄	7 ⁷ / ₈
14HA3B	1/4	90	23 ¹ / ₂	13	13 ³ / ₈	18 ³ / ₈	23 ³ / ₄	7 ⁷ / ₈
14HA4B	1/3	90	23 ¹ / ₂	13	13 ³ / ₈	18 ³ / ₈	23 ³ / ₄	7 ⁷ / ₈
14HA5B	1/2	105	23 ¹ / ₂	13	13 ³ / ₈	18 ³ / ₈	23 ³ / ₄	7 ⁷ / ₈
18HA1B	1/4	105						
18HA2B	1/4	115	26	14	14 ³ / ₈	17 ⁷ / ₈	26 ¹ / ₄	8 ³ / ₄
18HA3B	1/3	115	26	14	14 ³ / ₈	17 ⁷ / ₈	26 ¹ / ₄	8 ³ / ₄
18HA4B	1/2	115	26	14	14 ³ / ₈	17 ⁷ / ₈	26 ¹ / ₄	8 ³ / ₄
18HA5B	3/4	120	26	14	14 ³ / ₈	17 ⁷ / ₈	26 ¹ / ₄	8 ³ / ₄
24HA1B	1/4	155						
24HA2B	1/3	160	37	14 ¹ / ₂	14 ⁷ / ₈	17 ³ / ₈	37 ¹ / ₄	11 ¹¹ / ₁₆
24HA3B	1/2	160	37	14 ¹ / ₂	14 ⁷ / ₈	17 ³ / ₈	37 ¹ / ₄	11 ¹¹ / ₁₆
24HA4B	3/4	180	37	14 ¹ / ₂	14 ⁷ / ₈	17 ³ / ₈	37 ¹ / ₄	11 ¹¹ / ₁₆
24HA5B	1	180	37	14 ¹ / ₂	14 ⁷ / ₈	17 ³ / ₈	37 ¹ / ₄	11 ¹¹ / ₁₆
30HA1B	1/3	250						
30HA2B	1/2	255	46	16 ¹ / ₄	16 ⁵ / ₈	20 ³ / ₈	46 ¹ / ₄	15 ¹ / ₈
30HA3B	3/4	255	46	16 ¹ / ₄	16 ⁵ / ₈	20 ³ / ₈	46 ¹ / ₄	15 ¹ / ₈
30HA4B	1	260	46	16 ¹ / ₄	16 ⁵ / ₈	20 ³ / ₈	46 ¹ / ₄	15 ¹ / ₈
30HA5B	1 ¹ / ₂	260	46	16 ¹ / ₄	16 ⁵ / ₈	20 ³ / ₈	46 ¹ / ₄	15 ¹ / ₈
30HA6B	2	300	46	16 ¹ / ₄	16 ⁵ / ₈	20 ³ / ₈	46 ¹ / ₄	15 ¹ / ₈

D-3100-2B

Dimension 'A' is the outside of the housing and the louver. Dimension 'D' is the outside of the trim angle.



Fiber-Aire® MA



Series MA

Application

Fiber-Aire® Series MA (square) relief ventilators are molded of tough, chemical resistant polyester resins and heavy-weave glass cloth. All products are designed for simple installation and maintenance. The resulting products deliver superior performance, with minimal downtime and maintenance and the best full life value of any ventilation product available.

This unit can be used for three different ventilation applications:

- To provide relief for positive pressure.
- To provide gravity exhaust of heat and smoke.
- To provide air intake supply.

Pressure Drop Through Damper & Bird Screen

VELOCITY	STATIC PRESSURE DROP THROUGH	
	DAMPER	BIRD SCREEN
300	0.036	0.011
400	0.042	0.014
500	0.048	0.016
600	0.051	0.021
700	0.063	0.025
800	0.072	0.028
900	0.080	0.032
1000	0.089	0.035

The Relief Fiber-Aire® Series MA ventilators are often used in conjunction with air make-up units and unit ventilators, as well as duct weather caps to match other Fiber-Aire® powered units on the roof.

The simple, two-piece fiberglass housing is strong and efficient, never needs painting and remains unaffected by weather and most chemicals. The molded-in beige color and low silhouette make it inconspicuous from the street.

Sizes and Capacities

- Square throat sizes 6" to 60"
- Airflow to 40,000 CFM
- Static pressures to 1" w.g.

Construction Features

- Molded fiberglass housings are virtually impossible to dent, crack or break and resist weather, salt spray, and most chemicals.
- Simple, two-piece, low-silhouette fiberglass housing for strength and efficiency.
- Housing shock-resistant and sound-absorbing.
- Series FR outlet is molded venturi type with epoxy coated airflow guides.
- ½" x ½" PVC coated bird screen is standard on all units.

Accessories

- Gravity and motor operated backdraft dampers
- Fiberglass roof curbs

VELOCITY	STATIC PRESSURE DROP THROUGH	
	DAMPER	BIRD SCREEN
1250	0.111	0.045
1500	0.133	0.052
1750	0.156	0.062
2000	0.178	0.070
2500	0.222	0.089
3000	0.267	0.106
3400	0.302	0.122



MA

Model MA - Square

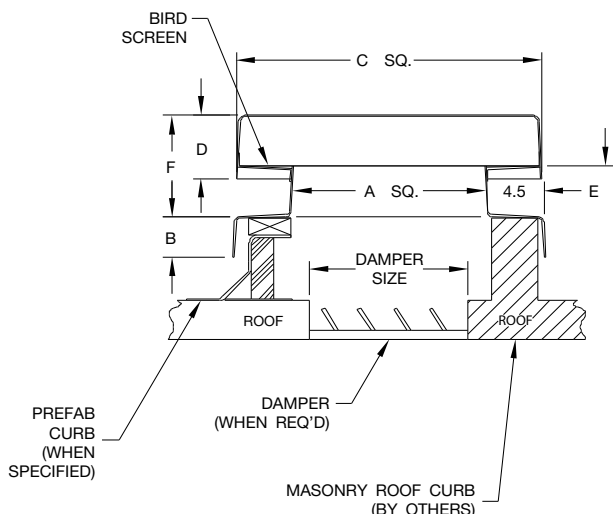

MODEL NO.	DIMENSIONS (IN.)						DAMPER (IN. x IN.)	CURB SQ. O.D.
	A	B	C	D	E	F		
MA 6	6.00	2.00	12.50	5.00	3.00	7.00	4 x 4	14
MA 8	8.00	2.00	12.50	5.00	3.00	7.00	6 x 6	16
MA10	10.00	2.00	17.50	8.00	4.00	11.00	8 x 8	18
MA12	12.00	2.00	22.00	8.00	4.00	11.00	10 x 10	20
MA15	15.00	3.00	24.00	8.00	4.00	11.00	14 x 14	24
MA18	18.00	3.00	30.00	8.00	4.00	11.00	16 x 16	26
MA20	20.00	3.00	31.50	12.00	6.00	16.00	18 x 18	28
MA24	24.00	3.00	38.00	12.00	6.00	16.00	22 x 22	32
MA30	30.00	3.00	47.50	14.69	6.00	18.69	28 x 28	38
MA34	34.00	3.00	54.00	14.69	6.00	18.69	32 x 32	42
MA36	36.00	3.00	57.00	15.00	7.00	20.00	34 x 34	44
MA38	38.00	3.00	64.50	15.00	7.00	20.00	36 x 36	46
MA42	42.00	3.00	66.00	15.00	7.00	20.00	40 x 40	50
MA48	48.00	3.00	75.00	18.00	8.00	24.00	46 x 46	56
MA54	54.00	3.00	85.00	20.00	13.00	31.00	52 x 52	62
MA60	60.00	3.00	85.00	20.00	13.00	31.00	58 x 58	68

D-3500-2A

MA PERFORMANCE DATA

Model MA - Square

MODEL NO.	SIZE (IN.)	AREA (FT.)	STATIC PRESSURE LOSS (IN. H ₂ O)																												
			500 CFM		1000 CFM		1500 CFM		2000 CFM		3000 CFM		4000 CFM		5000 CFM		6000 CFM		7000 CFM		8000 CFM		9000 CFM		10000 CFM		12000 CFM		15000 CFM		
			VEL	SP	VEL	SP	VEL	SP	VEL	SP	VEL	SP	VEL	SP	VEL	SP	VEL	SP	VEL	SP	VEL	SP	VEL	SP	VEL	SP	VEL	SP	VEL	SP	
MA6	6 x 6	0.250	2000	0.435																											
MA8	8 x 8	0.444	1125	0.137	2250	0.550																									
MA10	10 x 10	0.694	720	0.056	1440	0.225	2160	0.5070																							
MA12	12 x 12	1.000	500	0.027	1000	0.109	1500	0.2450	2000	0.435																					
MA15	15 x 15	1.560	320	0.011	640	0.045	960	0.1000	1280	0.178	1920	0.401	2560	0.712																	
MA18	18 x 18	2.250			445	0.021	667	0.0480	890	0.086	1333	0.193	1780	0.342	2220	0.536	2666	0.772													
MA20	20 x 20	2.780			360	0.014	540	0.0317	720	0.056	1080	0.127	1440	0.225	1800	0.352	2160	0.507	2520	0.690	2880	0.901									
MA24	24 x 24	4.000					375	0.0150	500	0.027	750	0.061	1000	0.109	1250	0.170	1500	0.245	1750	0.333	2000	0.435	2250	0.550	2500	0.680	3000	0.980	3750	0.153	

MODEL NO.	SIZE (IN.)	AREA (FT.)	STATIC PRESSURE LOSS (IN. H ₂ O)																												
			2000 CFM		3000 CFM		4000 CFM		5000 CFM		6000 CFM		8000 CFM		10000 CFM		12000 CFM		15000 CFM		20000 CFM		25000 CFM		30000 CFM		35000 CFM		40000 CFM		
			VEL	SP	VEL	SP	VEL	SP	VEL	SP	VEL	SP	VEL	SP	VEL	SP	VEL	SP	VEL	SP	VEL	SP	VEL	SP	VEL	SP	VEL	SP	VEL	SP	
MA30	30 x 30	6.250	320	0.011	480	0.025	640	0.045	800	0.070	960	0.100	1280	0.178	1600	0.278	1920	0.400	2400	0.626											
MA34	34 x 34	8.027			372	0.015	498	0.027	622	0.042	748	0.061	996	0.108	1245	0.170	1495	0.243	1868	0.379	2490	0.675									
MA36	36 x 36	9.000			333	0.012	444	0.021	555	0.033	666	0.048	888	0.086	1111	0.135	1333	0.193	1666	0.302	2222	0.536	2777	0.837							
MA38	38 x 38	10.050			300	0.010	400	0.017	500	0.027	600	0.039	800	0.070	1000	0.109	1200	0.157	1500	0.245	2000	0.435	2500	0.680	3000	0.980					
MA42	42 x 42	12.250					326	0.011	412	0.018	490	0.026	652	0.046	815	0.072	980	0.104	1225	0.163	1633	0.290	2040	0.452	2450	0.652	2855	0.886			
MA48	48 x 48	16.000									375	0.015	500	0.027	625	0.042	750	0.061	940	0.096	1250	0.170	1562	0.265	1875	0.382	2190	0.522	2500	0.680	
MA54	54 x 54	20.250									296	0.009	395	0.017	494	0.026	593	0.038	742	0.060	980	0.104	1235	0.166	1482	0.239	1730	0.325	1975	0.424	
MA60	60 x 60	25.000											320	0.011	400	0.017	480	0.025	600	0.039	800	0.070	1000	0.109	1200	0.157	1400	0.213	1600	0.278	

FIBERGLASS ROOF CURBS

Series EF (w/insulation)

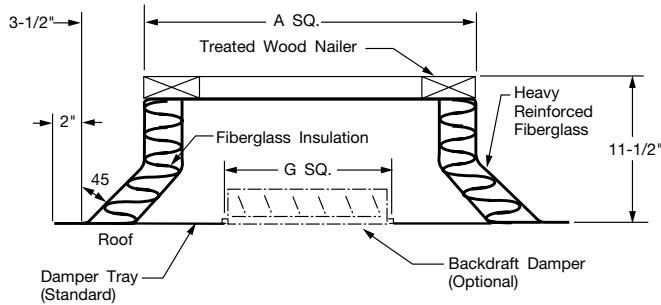

Series E

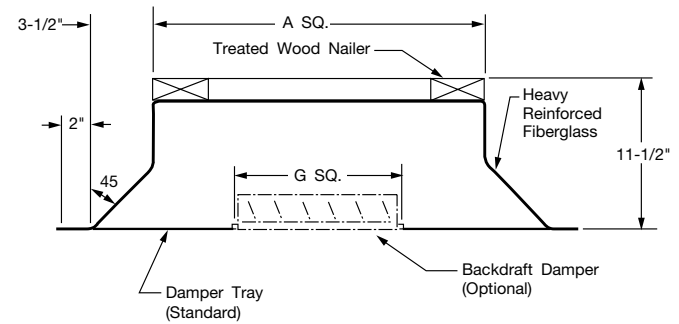

E12F — A 12" high, beige color, molded fiberglass, reinforced polyester resin, double shell, prefabricated roof curb with a 3½" cant, corner gussets, 2" thick fiberglass insulation, and incorporating a treated 1½" x 3½" treated wood nailer and damper tray.

E12 — A 12" high, beige color, molded fiberglass, reinforced polyester resin, single shell, prefabricated roof curb with a 3½" cant, corner gussets, and incorporating a treated 1½" x 3½" treated wood nailer and damper tray.

FAN / HOOD			ROOF CURB DIM. A (SQ)	12" HIGH CURB WITH INSULATION		12" HIGH CURB NON-INSULATED		G (SQ)	DAMPER SIZE WHEN REQ'D
MODEL	SIZE	BASE I.D.		PART NUMBER	APPROX. SHIP WT. (LB)	PART NUMBER	APPROX. SHIP WT. (LB)		
FA	7, 9	22 x 22	20 x 20	15025104	38	15025004	31	10.63	10 x 10
	10, 12, 14	26 x 26	24 x 24	15025105	46	15025005	38	14.63	14 x 14
	18	30 x 30	28 x 28	15025107	53	15025007	44	18.63	18 x 18
FAB	12, 14	26 x 26	24 x 24	15025105	46	15025005	38	14.63	14 x 14
	18	30 x 30	28 x 28	15025107	53	15025007	44	18.63	18 x 18
	24	37 x 37	36 x 36	15025109	68	15025009	56	24.63	24 x 24
	30	45 x 45	44 x 44	15025112	82	15025012	67	30.63	30 x 30
	36, 40	53 x 53	52 x 52	15025115	99	15025015	80	36.63	36 x 36
WA	7	17 x 17	16 x 16	15025102	31	15025002	26	6.63	6 x 6
	10, 12	21 x 21	20 x 20	15025104	38	15025004	31	10.63	10 x 10
	14	24.8 x 24.8	24 x 24	15025105	46	15025005	38	14.63	14 x 14
	18	29 x 29	28 x 28	15025107	53	15025007	44	18.63	18 x 18
WAB	14	24.8 x 24.8	24 x 24	15025105	46	15025005	38	14.63	14 x 14
	18	29 x 29	28 x 28	15025107	53	15025007	44	18.63	18 x 18
	24	37.5 x 37.5	36 x 36	15025109	68	15025009	56	24.63	24 x 24
	30	45.5 x 45.5	44 x 44	15025112	82	15025012	67	30.63	30 x 30
	36, 40	53 x 53	52 x 52	15025115	99	15025015	80	36.63	36 x 36
MA	6	15 x 15	14 x 14	15025101	28	15025001	24	4.63	4 x 4
	8	17 x 17	16 x 16	15025102	31	15025002	26	6.63	6 x 6
	10	19 x 19	18 x 18	15025103	34	15025003	28	8.63	8 x 8
	12	21 x 21	20 x 20	15025104	38	15025004	31	10.63	10 x 10
	15	24.3 x 24.3	24 x 24	15025105	46	15025005	38	14.63	14 x 14
	18	27 x 27	26 x 26	15025106	49	15025006	41	16.63	16 x 16
	20	29 x 29	28 x 28	15025107	53	15025007	44	18.63	18 x 18
	24	33 x 33	32 x 32	15025108	60	15025008	49	22.63	22 x 22
	30	39 x 39	38 x 38	15025110	72	15025010	59	28.63	28 x 28
	34	43 x 43	42 x 42	15025111	76	15025011	63	32.63	32 x 32
	36	45.5 x 45.5	44 x 44	15025112	82	15025012	67	34.63	34 x 34
	38	47.5 x 47.5	46 x 46	15025113	86	15025013	71	36.63	36 x 36
	42	51.5 x 51.5	50 x 50	15025114	92	15025014	75	40.63	40 x 40
	48	57.5 x 57.5	56 x 56	15025116	108	15025016	88	46.63	46 x 46
	54	63.5 x 63.5	62 x 62	15025117	119	15025017	96	52.63	52 x 52
60	69.5 x 69.5	68 x 68	15025118	130	15025018	105	58.63	58 x 58	

NOTE: Damper to be flanged.

Dimensions are not to be used for construction.

Fiberglass centrifugal roof and wall ventilators shall be Fiber-Aire® downblast Model FA direct drive / FAB belt driven, Whirlout® upblast Model WA direct drive / WAB belt driven, Hid-N-Aire® wall flush mounted Model HA direct drive / HAB belt driven, Fiber-Aire® wall Model SA direct drive or Fiberglass relief and gravity roof ventilators shall be Module-Aire® Model MA (square) as manufactured by Twin City Fan & Blower, Minneapolis, MN. Ventilators shall be specifically designed for the exhaust of moisture-laden, corrosive, or chemically contaminated air. Fiberglass, non-powered roof ventilators shall be molded with aerodynamically shaped venturi to provide minimum system resistance within gravity or positive pressure systems.

PERFORMANCE — Fans shall be tested in accordance with AMCA test codes for air moving devices and shall be guaranteed by the manufacturer to deliver rated published performance levels.

CONSTRUCTION — (All Models Except MA) - Fan housings including aerodynamically shaped inlet venturi, windband skirt, and motor cover (FA, FAB, WA, WAB, SA) shall be molded of high quality, beige-colored, fiberglass reinforced plastic resulting in assemblies that are virtually impossible to dent, crack, or break and are highly resistant to the effects of weather, salt spray, and most chemicals. Polyester resin shall be used to provide high strength and chemical resistance. The resin shall provide fire retardancy with a flame spread rating of 25 or less as tested per ASTM-E84. Further, all component plastic surfaces shall be gel coated to provide UV protection and added corrosion protection. All fan housings shall have PVC encapsulated ½" x ½" mesh screens or guards fitted to the ventilator to keep out birds, leaves, or other debris.

After fabrication all structural mild steel components in contact with the exhaust airstream (including the wall box on HA/HAB) shall be black epoxy coated (2 mils DFT minimum) for additional chemical resistance.

(MA) - Ventilators shall be a simple two-piece assembly that includes a curb cap base and top cap and ½" x ½" PVC birdscreen.

(HA/HAB) - The Hid-N-Aire® ventilator shall consist of a fiberglass inlet venturi panel bolted to a wall box that contains a belt driven impeller assembly prewired with a plug and cord, a plug-in electrical receptacle mounted to the inside of the wall box and an extruded aluminum exterior louver with integral PVC bird screen and automatic fabric backdraft damper. The entire power assembly including the motor, mounting plate on vibration isolation, fan shaft and bearings and impeller assembly shall be easily removable from either the interior or exterior of the building by removing the exterior louver or the fiberglass inlet venturi panel. Only four bolts must be removed to easily slide the power assembly out from the wall box.

WHEELS — (All Models Except MA) - Fan impellers shall be of the flat bladed, backward inclined type, polypropylene construction, securely fixed to a cast aluminum hub. Blade is of the non-overloading design to couple non-overloading power limiting characteristics with performance of the highest efficiency and lowest noise generation.

The fan impeller shall be secured to the motor or fan shaft with knurled cup point setscrews. All recommended lubrication and maintenance shall be accomplished without removal or disassembly of the fan impeller.

DRIVES & BEARINGS (FAB, WAB, HAB) — All motors and drives for belt driven fans (except HAB) shall be located outside of the exhaust airstream, covered and protected from the weather by the fiberglass fan top cap, and cooled by fresh air separate from the exhaust. Belt driven fan drives shall be sized for a minimum of 150% of driven horsepower. Belt driven fans shall be provided with machined, cast iron motor sheaves that shall be adjustable for final system balance. Fan shafts shall be precision ground and polished 304 SS. Shafts shall have a first critical speed of at least 125% of the fan's maximum operating speed. Bearings for belt driven fans shall be of the one-piece, cast iron, pillow block type with relubricable zerk fittings. Bearings shall be designed for service with a minimum L-10 life as defined by AFBMA in excess of 40,000 hours (200,000 hours L-50 average life) at the maximum cataloged operating speed.

MOTORS — (All Models Except MA) - All fan motors shall be closely matched to the fan load and located outside of the exhaust airstream, covered and protected from the weather by the fiberglass fan motor cover, and cooled by fresh air separate from the exhaust (except HA, HAB). All motors shall be cULus recognized.

(FA, FAB, WA, WAB, SA) - Electrical wire leads of the motor shall be extended by the factory through an airtight vinyl coated flexible metal conduit and be wired to a properly sized nonfused disconnect switch contained within a terminal junction box mounted under the fan motor cover. To simplify installation, a conduit chase constructed of airtight vinyl coated flexible metal conduit shall be provided through fiberglass curb cap (FA, FAB, WA, WAB) or fiberglass inlet venturi (SA) to the motor compartment for field supply conductors.

(HA/HAB) - Motors shall be prewired with a plug and cord for insertion into a properly sized terminal junction box mounted inside the wall housing.

FACTORY RUN TEST — (All Models Except MA) - All fans prior to shipment shall be completely assembled and test run as a unit at the specified operating speed or maximum RPM allowed for the particular construction type. Each wheel shall be statically and dynamically balanced in accordance with ANSI/AMCA 204-96 "Balance Quality and Vibration Levels for Fans" to Fan Application Category BV-3, Balance Quality Grade G6.3. Balance readings shall be taken by electronic type equipment in the axial, vertical, and horizontal directions on each of the bearings. Records shall be maintained and a written copy shall be available upon request.

GUARANTEE — The manufacturer shall guarantee the workmanship and materials for its fiberglass ventilators for at least one (1) year from startup or eighteen (18) months from shipment, whichever occurs first.

INDUSTRIAL PROCESS AND COMMERCIAL VENTILATION SYSTEMS

CENTRIFUGAL FANS | UTILITY SETS | PLENUM & PLUG FANS | INLINE CENTRIFUGAL FANS
MIXED FLOW FANS | TUBEAXIAL & VANEAXIAL FANS | PROPELLER WALL FANS | PROPELLER ROOF VENTILATORS
CENTRIFUGAL ROOF & WALL EXHAUSTERS | CEILING VENTILATORS | GRAVITY VENTILATORS | DUCT BLOWERS
RADIAL BLADED FANS | RADIAL TIP FANS | HIGH EFFICIENCY INDUSTRIAL FANS | PRESSURE BLOWERS
LABORATORY EXHAUST FANS | FILTERED SUPPLY FANS | MANCOOLERS | FIBERGLASS FANS | CUSTOM FANS



TWIN CITY FAN & BLOWER
WWW.TCF.COM

5959 TRENTON LANE N | MINNEAPOLIS, MN 55442 | PHONE: 763-551-7600 | FAX: 763-551-7601

©2018 Twin City Fan Companies, Ltd., Minneapolis, MN. All rights reserved. Catalog illustrations cover the general appearance of Twin City Fan & Blower products at the time of publication and we reserve the right to make changes in design and construction at any time without notice.