



3900 Dr. Greaves Rd. • Kansas City, MO 64030 • (816) 761-7476 • FAX (816) 765-8955

TED50
EXTRUDED ALUMINUM INSULATED AIRFOIL BLADE DAMPER
AMCA Class IA Leakage Rated

APPLICATION

Ruskin model TED50 is a low leak, thermally efficient damper with insulated extruded aluminum blades specially designed for reliable performance in cold temperature conditions. Each blade has a thermal break that is strategically placed between twin blade edge seals. The twin seals create a neutral zone to ensure there is no thermal path. This feature eliminates thermal transfer and reduces potential for condensation. TED50 satisfies the leakage requirements of the International Energy Conservation Code (IECC).



STANDARD CONSTRUCTION

FRAME

Standard Channel:

5" (127) x 1" (25) x .125 (3) thick 6063T6 high yield aluminum.

Optional T-Flange:

6" (152) x 1 3/8" (35) x .125 (3) thick 6063T6 high yield aluminum with quick connect "T" flange frame

Optional Thermal Break:

6" (152) x 1" (25) thick 6063T6 high yield aluminum with thermal breaks in frame.

BLADE(S)

5/64" (2) 6063T6 high yield extruded aluminum with thermal break.

AXLES

7/16" (11) nominal hexagonal plated steel.

BEARINGS

Dual action polycarbonate internal hex rotating inside an Acetal Copolymer outer sleeve.

BLADE SEALS

Mechanically fastened extruded Ruskiprene™.

JAMB SEALS

Ribbed extruded Ruskiprene™.

LINKAGE

Swedgelock™ assembly plated steel concealed out of airstream. No field adjustment required.

OPERATOR SHAFT

- 1/2" (13) dia. x 6" (152) long plated steel shaft single section units.
- 1/2" (13) dia. jackshaft on multi-section assemblies up to 12 1/2 ft.² (3.8m²).
- 1" (25) dia. jackshaft multi-section assemblies over 12 1/2 ft.² (3.8m²) (1" dia shaft required on all multisection T-Flange units)

PRESSURE

Up to 8.0" water gage (2 kPa) pressure. (Refer to Chart)

VELOCITY

Up to 4,000 fpm (20.3 m/s). (Refer to Chart)

LEAKAGE

- Class 1A at 1" water gage (.25 kPa).
- Class 1 at 4" water gage (1 kPa).

TEMPERATURE RANGE

-45°F to 185°F (-43°C to 85°C).

MINIMUM SIZE

- Parallel blade unit: 6" x 6" (152 x 152). (T-Flange)
- Parallel blade unit: 8" x 8" (203 x 203). (Channel and break frame.)

Opposed blade unit: 8" x 11 1/2" (203 x 292).

MAXIMUM SIZE

- Single section: 60" x 72" (1524 x 1829) single section.
- Multiple section assembly: Unlimited size
- (Units over 60" w or 72" h (1524 x 1829) are built in multiple equal size sections)

NOTES

1. Values shown in parentheses () are millimeters unless otherwise indicated.



Highlights

- ▶ AMCA Class IA Leakage Rated
- ▶ Insulated airfoil blade, low pressure drop
- ▶ Twin seals isolate blade thermal break
- ▶ R Value = 2.16 (tested to ASTM 1363)

VARIATIONS

Ruskin model TED50 is available with the following variations at additional cost

- Front or rear flange frame
- Thermal break in frame
- Quick connect "T" flange frame (reduces pressure drop)
- Stainless steel linkage
- Stainless axles and bearings
- Clear anodized finish (On some frame options)
- Factory furnished and commissioned actuators

DIMENSIONAL DETAILS

Frame styles dimensioned to O.D. of frame

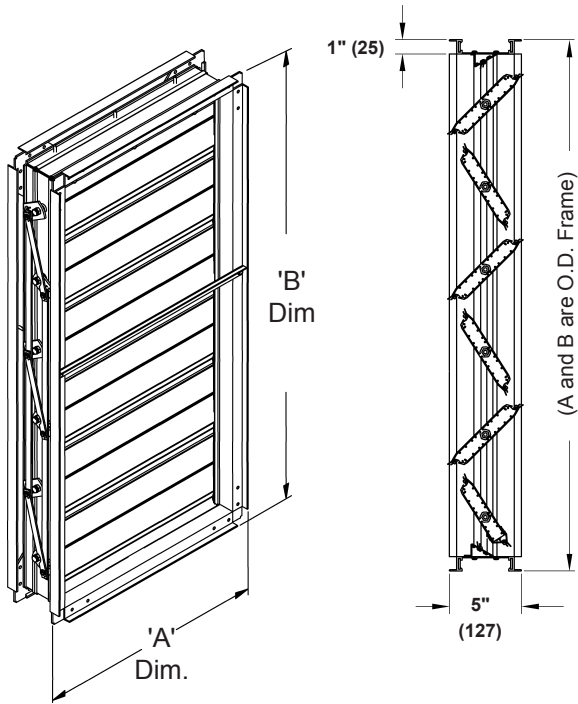

CHANNEL FRAME

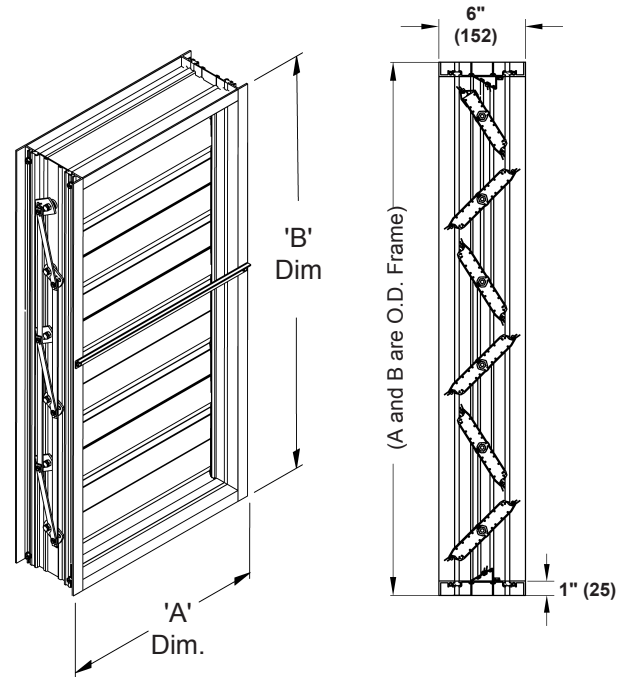

THERMAL BREAK FRAME

Frame style dimensioned to I.D. of frame

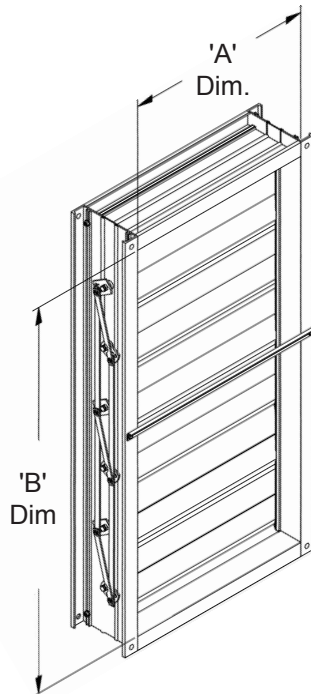

T-FLANGE FRAME

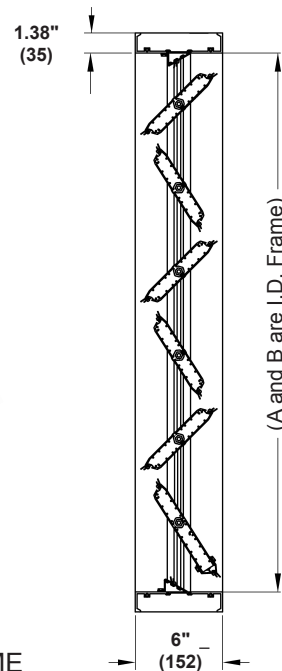

ADDITIONAL DETAILS

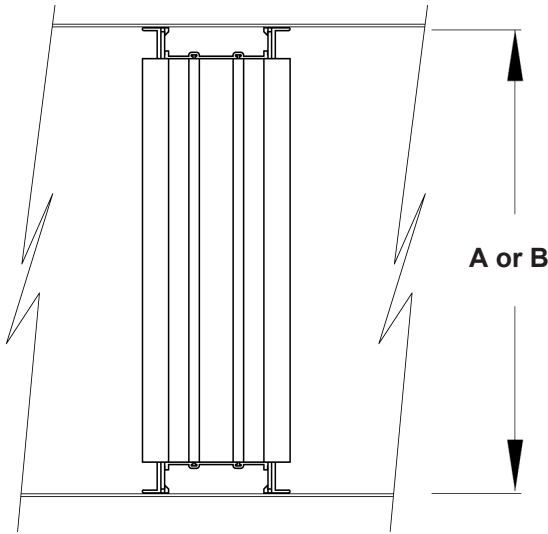

Channel Frame In Duct Mounted
A x B dimensions are to O.D. of damper frame

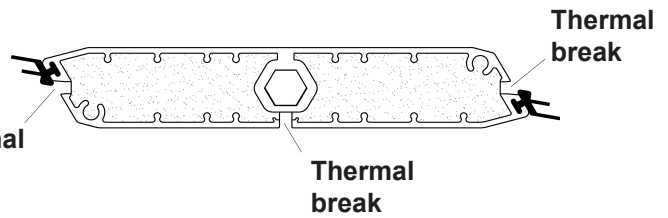

Blade Detail

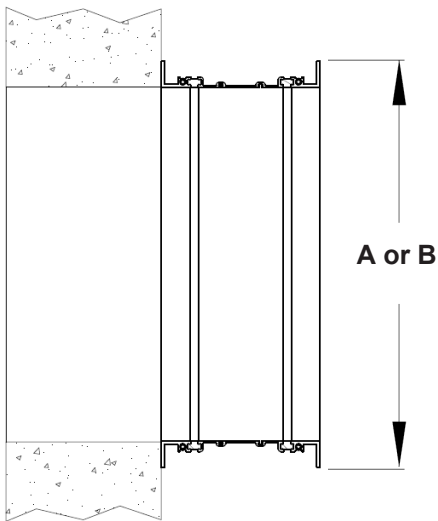

Thermal Broke Frame On Wall Opening
A x B dimensions are to O.D. of damper frame

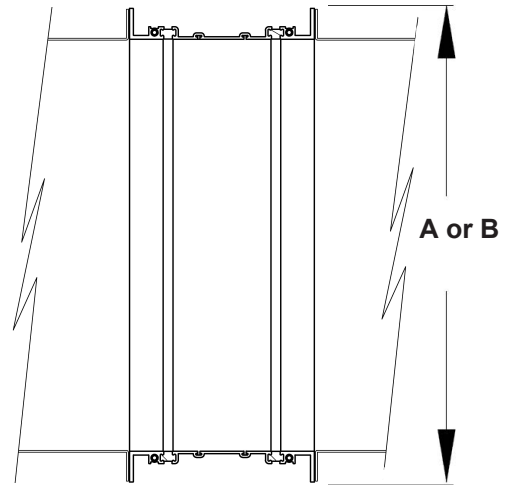

Thermal Broke Frame Flange Mounted

Add 2" to duct size dimensions when ordering.
Ex.
Duct size 24" x 24" = Damper A x B of 26" x 26"

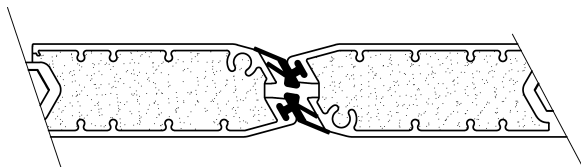

Blade Seal Detail

No thermal path from conditioned side to non-conditioned side of damper.

NOTES

1. Refer to Installation Instructions for additional details.

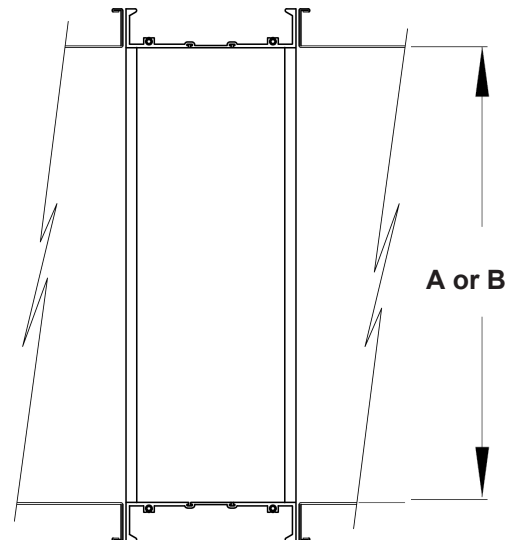

T-Flange Frame Mounting
A x B dimensions are to I.D. of damper frame

AIR PERFORMANCE DATA

TED50 air performance testing is performed in accordance with AMCA Standard 500-D configurations 5.2, 5.3 and 5.5 as illustrated below. All data has been corrected to standard air density of .075 lb/ft³ (1.201 kg/m³).

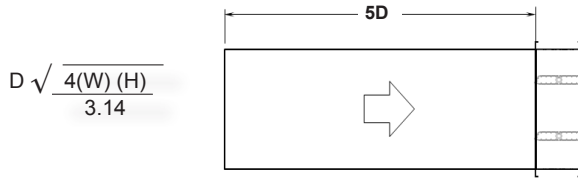

AMCA figure 5.2 was established to represent a ducted damper that is exhausting into an open area. In this configuration entrance losses are minimized by a straight duct run upstream of the damper.

12 x 12 (305 x 305)		24 x 24 (610 x 610)		36 x 36 (914 x 914)		12 x 48 (305 x 1219)		48 x 12 (1219 x 305)	
Velocity (fpm)	Pressure Drop (in.wg)	Velocity (fpm)	Pressure Drop (in.wg)	Velocity (fpm)	Pressure Drop (in.wg)	Velocity (fpm)	Pressure Drop (in.wg)	Velocity (fpm)	Pressure Drop (in.wg)
500	0.09	500	0.03	500	0.02	500	0.03	500	0.05
1000	0.38	1000	0.11	1000	0.08	1000	0.13	1000	0.21
1500	0.85	1500	0.25	1500	0.18	1500	0.30	1500	0.47
2000	1.50	2000	0.44	2000	0.33	2000	0.52	2000	0.83
2500	2.35	2500	0.69	2500	0.51	2500	0.82	2500	1.30
3000	3.41	3000	1.00	3000	0.74	3000	1.18	3000	1.87
3500	4.64	3500	1.36	3500	1.02	3500	1.60	3500	2.51
4000	6.06	4000	1.78	4000	1.33	4000	2.09	4000	3.28

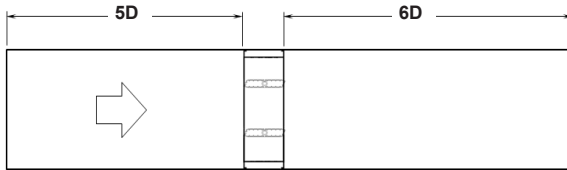

AMCA figure 5.3 was established to represent a fully ducted damper with straight duct upstream and downstream. With entrance and exit losses minimized by this straight duct arrangement, this configuration has the lowest pressure drop of all three configurations

12 x 12 (305 x 305)		24 x 24 (610 x 610)		36 x 36 (914 x 914)		12 x 48 (305 x 1219)		48 x 12 (1219 x 305)	
Velocity (fpm)	Pressure Drop (in.wg)	Velocity (fpm)	Pressure Drop (in.wg)	Velocity (fpm)	Pressure Drop (in.wg)	Velocity (fpm)	Pressure Drop (in.wg)	Velocity (fpm)	Pressure Drop (in.wg)
500	0.06	500	0.01	500	0.01	500	0.02	500	0.03
1000	0.24	1000	0.06	1000	0.03	1000	0.08	1000	0.10
1500	0.54	1500	0.13	1500	0.08	1500	0.16	1500	0.24
2000	0.97	2000	0.22	2000	0.13	2000	0.28	2000	0.41
2500	1.51	2500	0.34	2500	0.20	2500	0.44	2500	0.54
3000	2.18	3000	0.49	3000	0.29	3000	0.62	3000	0.93
3500	2.96	3500	0.65	3500	0.39	3500	0.84	3500	1.27
4000	3.86	4000	0.86	4000	0.51	4000	1.07	4000	1.65

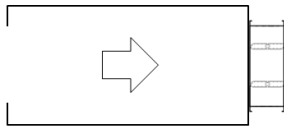

AMCA figure 5.5 was established to represent a damper installed on a plenum wall. Sudden area changes entering and exiting the damper create extreme losses, making this the highest pressure drop of the three configurations tested

12 x 12 (305 x 305)		24 x 24 (610 x 610)		36 x 36 (914 x 914)		12 x 48 (305 x 1219)		48 x 12 (1219 x 305)	
Velocity (fpm)	Pressure Drop (in.wg)	Velocity (fpm)	Pressure Drop (in.wg)	Velocity (fpm)	Pressure Drop (in.wg)	Velocity (fpm)	Pressure Drop (in.wg)	Velocity (fpm)	Pressure Drop (in.wg)
500	0.11	500	0.05	500	0.05	500	0.05	500	0.07
1000	0.45	1000	0.19	1000	0.19	1000	0.20	1000	0.28
1500	0.95	1500	0.42	1500	0.42	1500	0.45	1500	0.62
2000	1.68	2000	0.77	2000	0.74	2000	0.79	2000	1.09
2500	2.66	2500	1.17	2500	1.16	2500	1.24	2500	1.71
3000	3.84	3000	1.67	3000	1.66	3000	1.78	3000	2.46
3500	5.22	3500	2.29	3500	2.26	3500	2.42	3500	3.35
4000	6.82	4000	2.96	4000	2.95	4000	3.16	4000	4.37

Ruskin Company certifies that model TED50 shown herein is licensed to bear the AMCA seal. The AMCA Certified Ratings Seal applies to Air Leakage, Air Performance and Energy Efficiency ratings. The ratings shown are based on tests and procedures performed in accordance with AMCA publication 511 and comply with the requirements of the AMCA Certified Ratings Program



LEAKAGE DATA

Leakage testing is performed in accordance with ANSI/AMCA Standard 500-D, figure 5.
 Air performance testing is performed in accordance with ANSI/AMCA Standard 500-D, figures 5.2, 5.3 and 5.
 Data are based on a closing torque of 7 inch pounds /ft² (.79 N.m./m²) and operation between 32°-120°F (0°-49°C).

* Leakage Class Definition

As defined by AMCA, the maximum allowable leakage is as follows.

Leakage Class 1A (is only defined @ 1" wg
 - 3 cfm/ft² (.92 cmm/m²) @ 1" wg (0.25 kPa)

Leakage Class 1
 - 4 cfm/ft² (1.22 cmm/m²) @ 1" wg (0.25 kPa)
 - 8 cfm/ft² (2.44 cmm/m²) @ 4" wg (1 kPa)
 - 11 cfm/ft² (3.35 cmm/m²) @ 8" wg (2 kPa)

TED50	LEAKAGE CLASS*				
	Maximum Damper Height	1" w.g. (0.25 kPa)	4" w.g. (1 kPa)	8" w.g. (2 kPa)	10" w.g. (2.5 kPa)
60" (1524)	1A	1	1	1	1



Ruskin Company certifies that model TED50 shown herein is licensed to bear the AMCA seal. The AMCA Certified Ratings Seal applies to Air Leakage and Air Performance ratings. The ratings shown are based on tests and procedures performed in accordance with AMCA Publication 511 and comply with the requirements of the AMCA Certified Rating Program.

SUGGESTED SPECIFICATION

Furnish and install, where shown on plans and/or as indicated in schedules thermally efficient control dampers meeting the following minimum specifications

Damper shall be Ruskin TED50. Damper frame shall be constructed of 6063T6 high yield extruded aluminum with a minimum wall thickness of .07" (2) and a yield stress of no less than 30,000psi. Low pressure drop aerodynamically shaped blades shall be constructed of 6063T6 high yield extruded aluminum with a minimum wall thickness of .07 (2) and a yield stress of no less than 30,000psi. Blades shall be filled with Polyurethane structural foam with a minimum density of 15 pcf. Insulated blades shall include a thermal break positioned between two blade seals to completely eliminate a thermal path from one side of the damper to the other. Thermal breaks on the blade edges shall not be visible when the damper is in the closed position. Damper assembly shall have a symmetrical design to ensure the resistance to airflow is identical from either direction. Axles shall be 1/2" (13) hexagonal plated steel material. Stainless steel axles shall be utilized when noted on the plans. Polycarbonate bearings shall be formed to the shape of the axle to reduce leakage through the frame. Bearings shall rotate inside an Acetyl Copolymer outer bearing surface to reduce torque and promote a smooth operation throughout the stroke of the damper. Zero tolerance Swedgelock™ linkage arms shall be permanently and mechanically secured to each axle, eliminating future need for field adjustment of the linkage assembly. Linkage assembly shall be set to predetermined parameters ensuring leakage performance for the life of the product. Linkage shall be completely concealed within the damper frame, out of the airstream. Stainless steel linkage of the same design shall be used when specified on the plans. Blade edge seals shall be extruded Ruskiprene™ and shall be mechanically fastened to the blades. Jamb seals shall be low profile, light prohibiting, extruded Ruskiprene™ secured in extruded pockets of the damper frame. Stainless steel jamb seals creating a thermal path from one side of the blade to the other are not permitted. Damper shall be suitable for pressures up to 8 inches water gage (2kPa), velocities up to 4,000 fpm (20.3 m/s), standard air leakage of less than 8 cfm/ft² at 4 inches water gage (2.44 cmm/m² at 1 kPa), temperature range of -45°F to 185°F (-43°C to 85°C) and a thermal efficiency ratio no less than 345%. All performance data shall be submitted to engineer of record for approval. Damper leakage, performance, and thermal efficiency shall be developed in accordance with the latest edition of AMCA 500-D. Damper shall be licensed to bear the AMCA certified ratings seal for Class 1A Performance.



3900 Dr. Greaves Rd.
 Kansas City, MO 64030
 (816) 761-7476
 FAX (816) 765-8955
 www.ruskin.com