

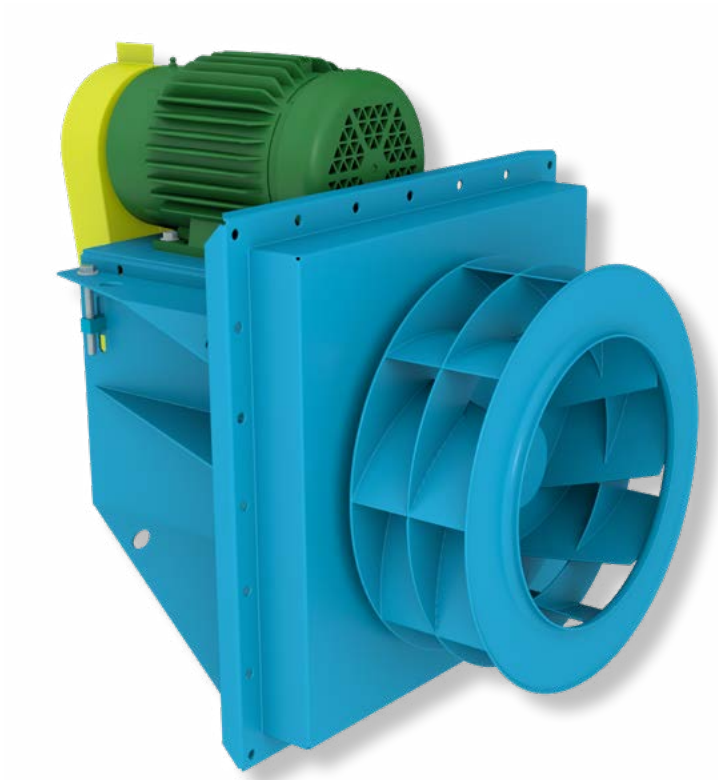

INDUSTRIAL PROCESS AND
COMMERCIAL VENTILATION SYSTEMS

HIGH EFFICIENCY PLUG FANS

MODEL BFPL



HIGH EFFICIENCY PLUG FANS



Overview

BFPL



Model BFPL,
Arrangement 9

Plug fans offer great versatility for complex system configurations. Equipped with a gusseted mounting panel, they are mounted directly to the plenum wall separating the motor and drive components from the process air. Plug fans provide high efficiency recirculation air with the benefit of easy installation and removal.

Typical Applications Include

Air Curtains, Dyers, Freezers, High Temperature, Kilns, Ovens, Process Applications, Product Cooling, Re-Circulation, Air Heaters, Ceiling, Wall and Floor Panel Plenums, Degreasers, Dryers, Dust Collectors, Evaporators, Packaged Air Handlers, Parts Washers, Penthouses, Smoke Houses, Space Heaters, Spray Booths and other High Temperature Applications

Wheel Types

Backward Curved

Arrangements

Available in Arrangement 1P, 9 and 9P (Belt Driven) and Arrangement 4, 4P and 8P (Direct Drive) configurations

Optional Construction

High-Temperature Construction to 1000° F, Insulated Plug, Pedestal Design for Floor Mounting, Spark Resistant Construction, Special Materials, All Welded Housing, Variable Inlet Vanes, Integral Inlet Cone Assembly, Shallow Depth Inlet Cone, Special Wheel Width and Diameter

Certifications

ATEX Construction

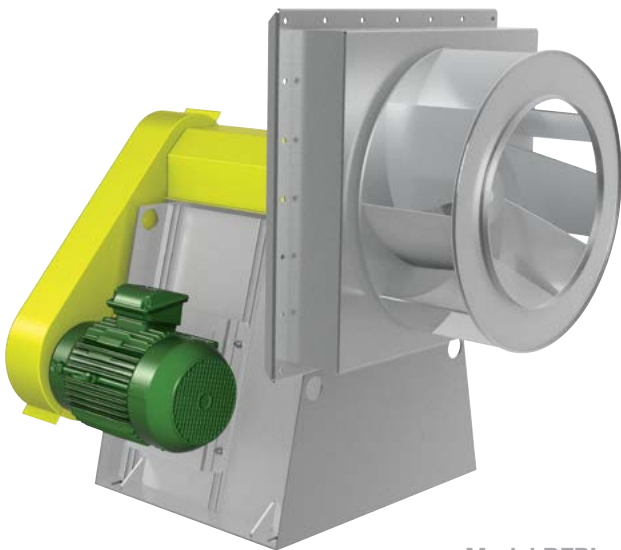

Model BFPL,
Arrangement 9P



For complete product performance, drawings and available accessories, download our Fan Selector program at tcf.com.

Overview

BFPL

BFPL plug fans from Twin City Fan & Blower are compact, versatile and offer the highest efficiency in the industry. Their versatility allows them to be used for air circulation in a variety of commercial and industrial applications including air curtains, air heaters, ceiling, wall and floor panel plenums, degreasers, dryers, dust collectors, evaporators, freezers, kilns, ovens, packaged air handlers, parts washers, penthouses, smoke houses, space heaters, spray booths and other high temperature applications.

Plug fans are housed in the customer's enclosure in applications where the system plenum acts as the fan housing. This configuration saves space since connecting ductwork and motor support pedestals are generally not needed. More space savings can be obtained by utilizing the wheel compartment as a pressurized chamber in lieu of a fan scroll. The use of multiple discharges from the pressurized chamber allows for additional savings by reducing ducting requirements.

BFPL plug fans feature SWSI backward curved, non-overloading, single thickness airfoil type wheels. The unique wheel offers increased efficiency over competitor's airfoil blade designs yet can handle airstreams not conducive to traditional hollow airfoil shapes.

The plug fan's motor and drive are protected from high temperatures by the customer's chamber wall or the optional 4" or 6" insulated plug. The motor and drive are mounted to the plug panel which may be bolted or welded in place. The plug assembly may be mounted with the shaft in either the vertical or horizontal position for maximum flexibility. Horizontal construction is standard. Vertical mounting can be provided when specified. An all welded housing and an integral inlet cone are available as options.

Sizes and Performance

12" to 49" wheel diameters (305 mm to 1,245 mm)
Airflow to 76,000 CFM (129,100 m³/hour)
Static pressure to 12" w.g. (2,980 Pa)



Paint Booth Ventilation

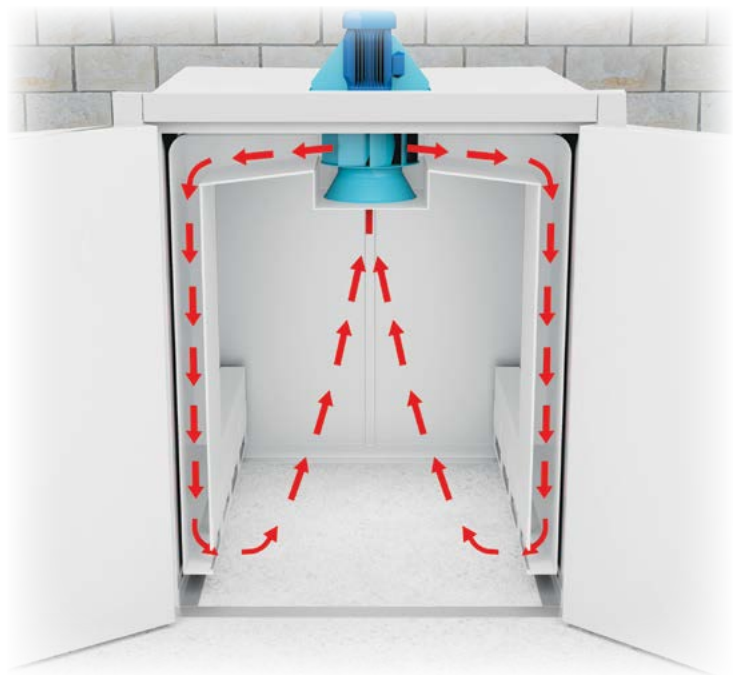

Oven Airflow

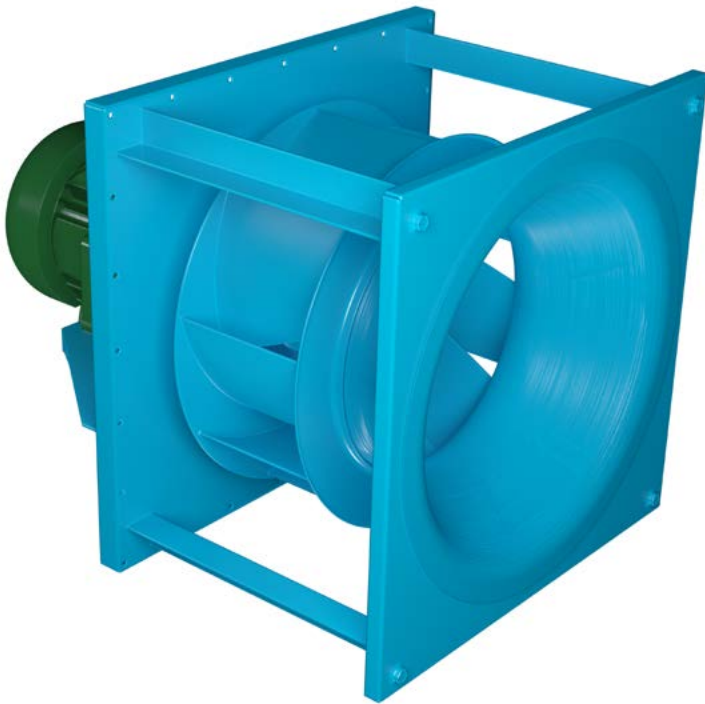

Non-Insulated,
Arrangement 4 BFPL

Plug Panel

Constructed of minimum 7-gauge steel with formed flanges to maintain flatness and rigidity. Panel is prepunched for bolt mounting. Panel assembly may also be welded in place. The “cross frame” bearing support is designed for maximum stability and load spreading. Bearings are serviceable without disassembly of panel or frame.

Plug Assembly

Available for both horizontal and vertical applications. Horizontal construction is standard. Vertical construction will be provided when specified.

Adjustable Motor Base

The motor base is standard with leveling and tension adjustment to ensure proper drive belt alignment. The motor base is heavy-gauge steel and prepunched to accept the standard motor frame specified.

Wheels

Wheels are assembled of die-formed, matched components, welded to both back plate and rim. Wheels are statically and dynamically balanced.

Inlet Cones

Heavy-gauge and spun to match the wheel intake rim to ensure smooth airflow. Inlet cone flange is prepunched for mounting. Inlet cones are shipped loose as standard. An integral inlet cone is optional.

Shafts

Standard shaft diameters are sized for plug thicknesses to 6 inches and 1000°F operation.

Bearings

Either ball or spherical roller, heavy-duty, self-aligning, pillow block type bearings are provided. Bearing selection is based on L-10 minimum life of 40,000 hours or average life of 200,000 hours. Split roller bearings are not recommended.

High Temperature Construction

301-500°F: Includes high temperature grease, expansion and non-expansion bearings, shaft seal and shaft cooler.

501-800°F: Includes the modifications above with the addition of high temperature aluminum paint. Minimum 4" insulation is required and is available as an optional item from TCF. Be sure to apply derating factors for high temperature construction. See Table 8 on page 11.

801-1000°F: Includes the modifications above with the addition of 316 stainless steel wheel and shaft. Also includes shaft extension for the required 6" insulation. 6" insulated plug is available as an optional item. Be sure to apply stainless steel derating factors for temperature. See Table 7 on page 11.

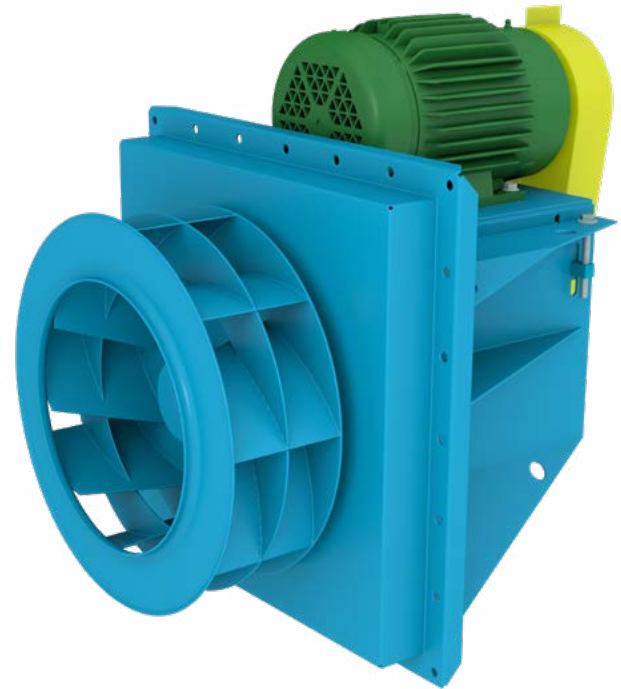

High Temperature,
Arrangement 9 BFPL

Insulated Plug

Protects motor and drive components from heat. An insulated plug is recommended for temperatures above 300°F. Available in 2", 4" and 6" thicknesses. Special thicknesses to match customer's insulated wall are available. Plug is assembled to mounting panel when ordered. See Table 1 on page 10 for maximum RPMs.

Spark Resistant Construction

Fan applications may involve the handling of potentially explosive or flammable particles, fumes or vapors. Such applications require careful consideration by the system designer to ensure the safe handling of such gases. Twin City Fan & Blower offers the following classifications of spark resistant construction per AMCA Standard 99-0401-86. It is the specifier or the user's responsibility to specify the type of spark resistant construction with full recognition of the potential hazards and the degree of protection required.

Type C - The fan shall be so constructed that a shift of the wheel or shaft will not permit two ferrous parts of the fan to rub or strike.

All Welded Housing

Heavy-gauge steel housing is provided with wheel opening on each side and weld studs on the inlet side for cone mounting. Specify rotation and discharge as viewed from drive side to ensure proper stud placement. Housing supports and attachments for wall mounting to be provided by others. See page 19 for dimensions.

Variable Inlet Vanes

Vane blades are cantilever design or center supported, equipped with permanently lubricated bearings and ball joints for smooth and easy operation. Vane assemblies are external type for sizes 121 through 161 and nested for sizes 181 through 491. Standard inlet vanes are applicable to 300°F. Consult factory for higher temperatures.

Integral Inlet Cone Assembly

Includes four pieces of angle, welded to the insulated plug or mounting panel, which serve to pre-align the inlet funnel within the wheel. The entire unit can be installed or removed through the same hole in the customer's enclosure, without the need for additional mounting or alignment of the inlet cone.

Shallow Depth Inlet Cone

The shallow inlet cone can shorten the overall length of the plug fan, providing extra space where needed. See dimensional data on page 19 for comparison between standard inlet cone and the shallow depth cone. Fan performance in smaller sizes must be derated for the modification. See Table 7 on page 11 for performance derates.

Arrangement 1P

Belt drive arrangement where the fan is mounted to grade and the motor is mounted separate from the fan. Typically used on larger fans and/or larger HP motors where the customer's wall may not be sufficient by itself. Mounting to the foundation also makes it better for meeting lower vibration requirements. Mounting panel is optional on arrangement 1P.



Arrangement 4

Direct drive arrangement where the wheel is mounted to the motor shaft. The design is more compact and requires less maintenance due to not having fan shaft, bearings or belts. High airstream temperatures may limit the use of this arrangement.



Arrangement 4P

Same as the arrangement 4 fan except the fan is mounted to grade. Typically used where the customer's wall may not be sufficient by itself. Mounting to the foundation also makes it better for meeting lower vibration requirements. Mounting panel is optional.



Arrangement 8P

Direct drive arrangement where the motor shaft is coupled to the fan shaft. The entire assembly is mounted to grade. Typically used on larger fans and/or larger HP motors where the customer's wall may not be sufficient by itself. Mounting to the foundation also makes it better for meeting lower vibration requirements. Mounting panel is optional.

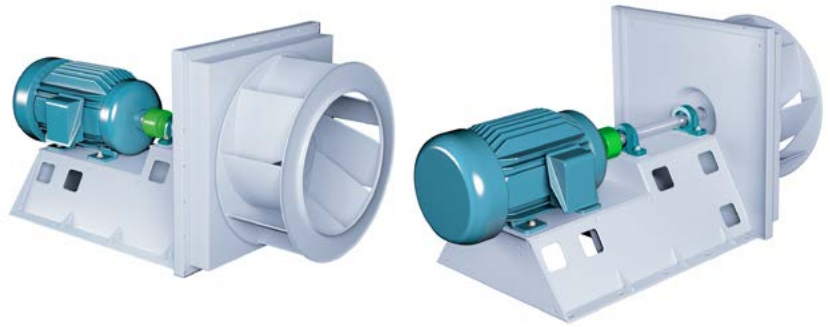
**Arrangement 9**

Arrangement 9 is the most common plug fan arrangement. It is fully supported by the customer's wall. Plug fans are housed in the customer's enclosure in applications where the system plenum acts as the fan housing. Unlike the plenum fan, motor, shaft and bearings are outside of the process airstream.

**Arrangement 9P**

Same as the arrangement 9 fan except the fan is mounted to grade. Typically used on larger fans and/or larger HP motors where the customer's wall may not be sufficient by itself. Mounting to the foundation also makes it better for meeting lower vibration requirements. Mounting panel is optional.

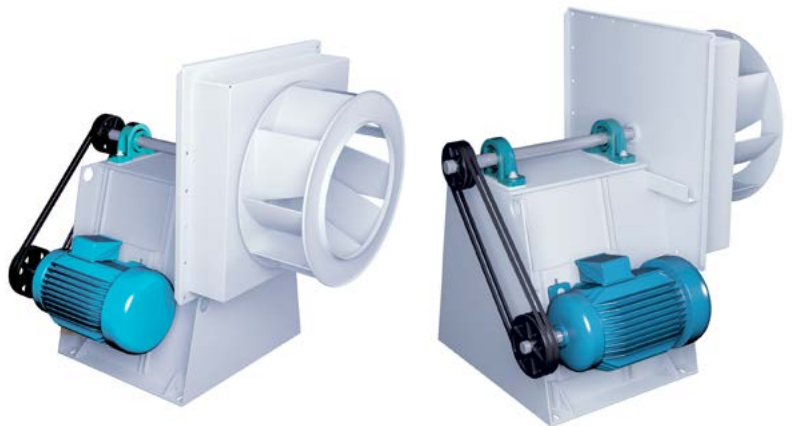

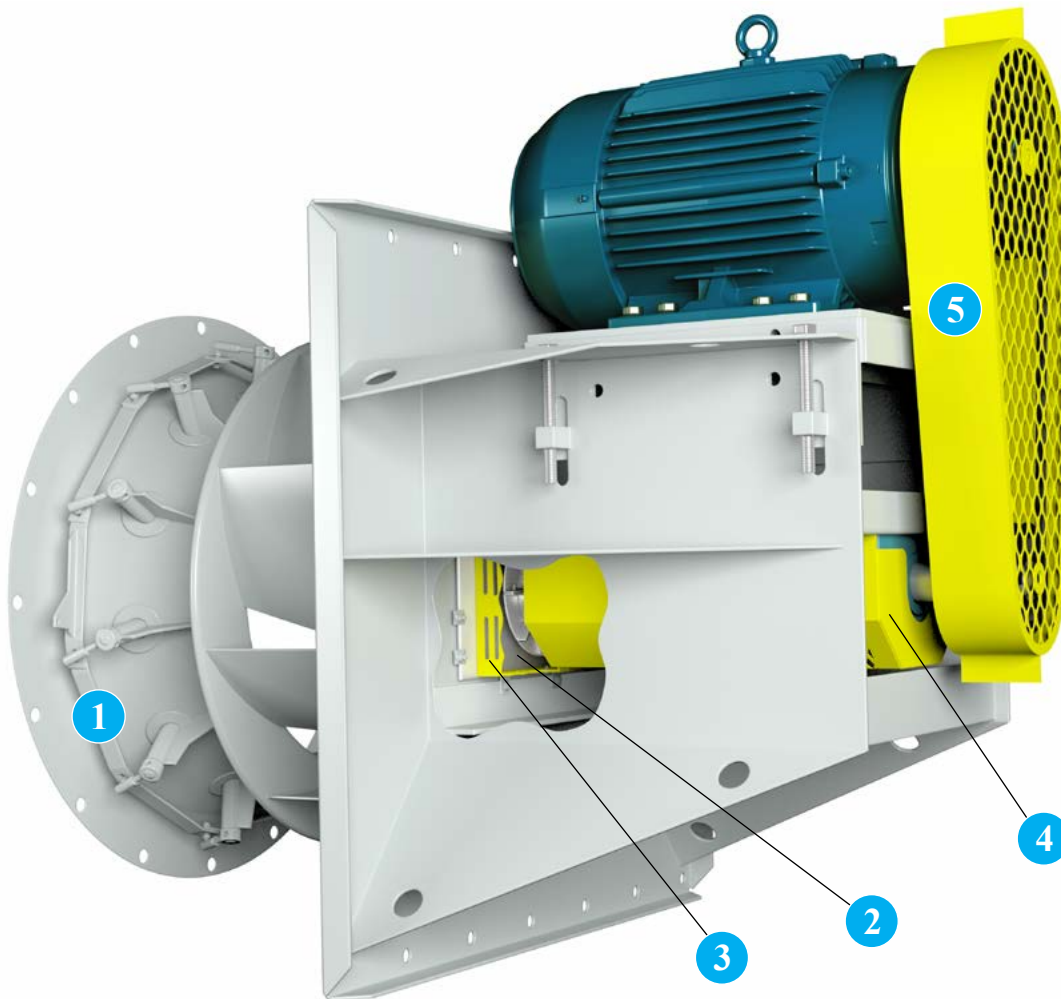

1 Inlet Vanes For reduced flow situations with relatively clean air, inlet vane type dampers are available to maintain fan efficiency. The inlet vanes are external type attached to the inlet of the fan. Standard construction inlet vanes are suitable in applications up to 300°F. High temperature inlet vanes are also available for temperatures up to 600°F.

2 Shaft Coolers Cast aluminum shaft cooler dissipates the heat transferred to the shaft from the airstream protecting the fan bearings. Recommended for applications over 300°F.

3 Shaft Seals reduce leakage and protect the bearings from a contaminated airstream. Standard seals are constructed of Tetraglas compressed between an aluminum cover plate and the fan housing. The standard shaft seal is not gas tight. Special seals are available for low leakage applications requiring more protection.

4 Shaft and Bearing Guards Sheet metal guards cover shaft and bearings and come with extended lube lines to a common point outside of the guard. A guard spanning the shaft between the bearings is available to provide open access to bearings for lubrication and vibration monitoring.

5 Belt Guards Belt guard protects personnel from the moving drive parts. OSHA and quick access guards are available.

Other Accessories Include:

- Piezometer Ring
- Inlet Screens
- Special Wheel Widths

Mounting is accomplished by providing a hole larger than the wheel diameter through the chamber wall. The wheel, shaft, motor and drive assembly is then positioned to the inlet cone (mounted in opposite wall) and secured in place. See Figure A.

Another method is to provide a hole sized only for the wheel drive shaft. The wheel is then positioned through the opening for the inlet cone after the drive and panel assembly has been securely mounted. See Figure B.

Plug fans may be applied with open wheel (unhoused) or with a housing as shown in Figure C. Performance data in this catalog is for unhoused wheel application.

Walls must be designed by the users to support the dynamic loads of the fan without resonance to eliminate vibration and bearing failure.

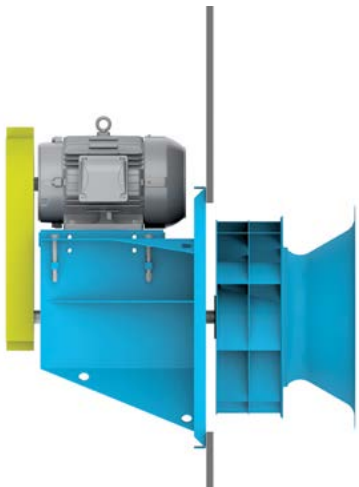

Figure A

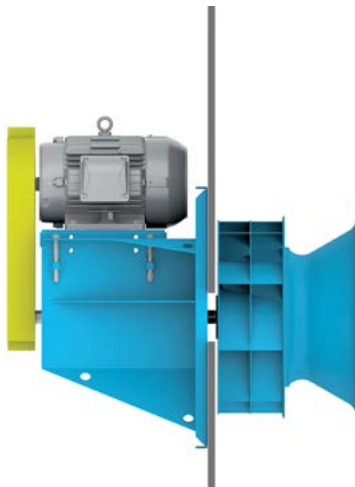

Figure B

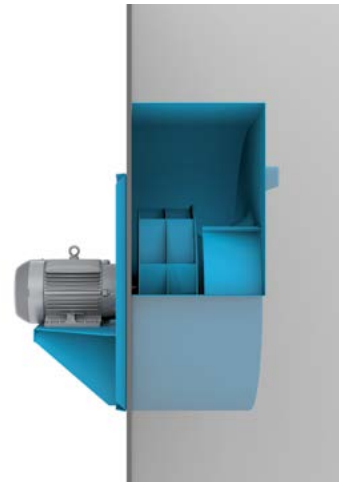

Figure C
(shown with optional housing)

MOUNTING ARRANGEMENTS



Horizontal



Vertical Down



Vertical Up

To ensure proper motor selection, consideration must be given to starting torque requirements (fan wheel inertia WR^2) along with the operating BHP. Table 1 lists the WR^2 factors for different wheel sizes to be used in evaluating

the capability of a selected motor. In some cases it may be necessary to provide a larger horsepower motor, even though it may not be dictated by the operating BHP, to bring the fan to speed.

Table 1. Maximum Fan RPMs, Wheel Weights and WR^2

FAN SIZE	CLASS II					CLASS III				
	MAXIMUM RPM			WHEEL WT. (LBS)	WR^2 (LBS-FT ²)	MAXIMUM RPM			WHEEL WT. (LBS)	WR^2 (LBS-FT ²)
	NO PLUG	4" PLUG	6" PLUG			NO PLUG	4" PLUG	6" PLUG		
121	3778	3000	3000	21	3	-	-	-	-	-
141	3352	3000	2875	24	4	-	-	-	-	-
161	2975	2975	2425	32	7	-	-	-	-	-
181	2644	2644	2275	52	13	3557	3000	3000	62	14
201	2380	2380	2200	58	18	3202	3000	2900	70	20
221	2125	2125	1850	75	31	2859	2859	2650	84	33
251	1889	1889	1700	96	50	2541	2541	2303	111	51
281	1676	1676	1676	140	94	2255	2255	1936	156	104
321	1487	1487	1487	173	152	2001	2001	1729	195	167
351	1322	1322	1322	211	241	1779	1779	1483	236	266
391	1190	1190	1190	254	376	1601	1601	1578	283	413
441	1062	1062	1062	361	613	1429	1429	1429	482	880
491	952	952	952	465	1025	1281	1281	1281	613	1450

Table 2. Bare Fan and Accessory Weights

FAN SIZE	APPROXIMATE WEIGHTS (LBS.)				
	BARE FAN		INSULATED PLUG	HOUSING	INLET VANES
	CLASS II	CLASS III			
121	140	-	25	24	45
141	145	-	25	30	52
161	185	-	32	44	58
181	208	444	32	65	29
201	221	470	32	79	33
221	235	513	35	97	38
251	240	594	35	117	40
281	323	756	40	143	45
321	388	990	55	287	50
351	430	1118	55	350	50
391	575	1467	75	428	55
441	639	1745	75	522	60
491	950	1900	95	634	65

Table 3. Shallow Inlet Cone Derates

FAN SIZE	INCREASE DESIGN SPEED BY	INCREASE DESIGN BHP BY
121 - 141	Not Available	Not Available
161 - 201	2%	4%
221 - 491	0%	0%

NOTE: Maximum RPMs in Table 1 cannot be exceeded.

Table 4. High Temperature Applications

TEMP. RANGE	BEARING TYPE	LUBRICATION	OTHER REQUIREMENTS
TO 300°F	BALL OR ROLLER	GREASE	STANDARD CONSTRUCTION
301 TO 500°F	EXPANSION AND NON-EXPANSION	HIGH TEMPERATURE GREASE	CERAMIC SHAFT SEAL, SHAFT COOLER
501 TO 800°F	EXPANSION AND NON-EXPANSION	HIGH TEMPERATURE GREASE	HIGH TEMPERATURE ALUMINUM PAINT 4" MINIMUM INSULATION REQUIRED BY TCF OR CUSTOMER CERAMIC SHAFT SEAL, SHAFT COOLER
801 TO 1000°F	EXPANSION AND NON-EXPANSION	HIGH TEMPERATURE GREASE	316 STAINLESS STEEL WHEEL AND SHAFT 6" MINIMUM INSULATION REQUIRED BY TCF OR CUSTOMER HIGH TEMPERATURE ALUMINUM PAINT CERAMIC SHAFT SEAL, SHAFT COOLER

Figure 1. Wheel and Plenum Arrangement

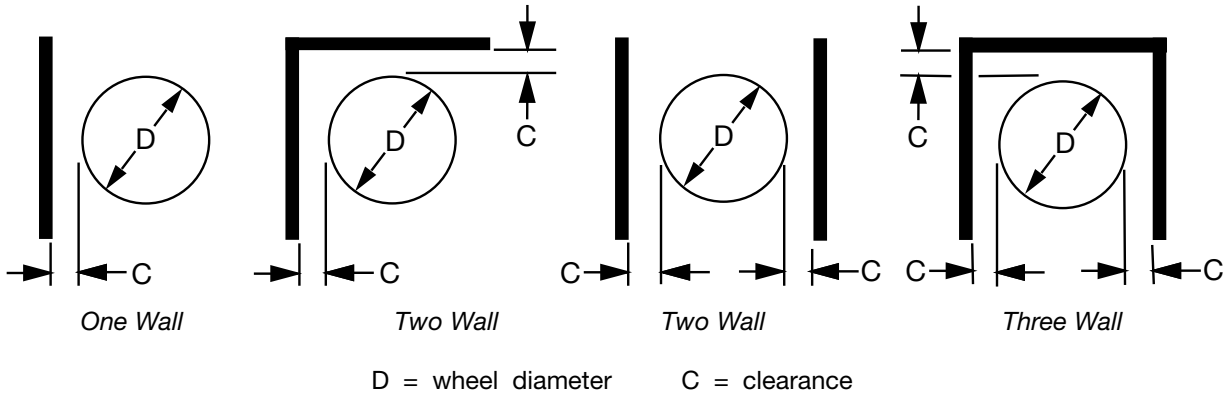

Table 5. Wall Proximity Factors

% WOV	FACTOR	C = D/8			C = D/4			C = D/2		
		ONE WALL	TWO WALL	THREE WALL	ONE WALL	TWO WALL	THREE WALL	ONE WALL	TWO WALL	THREE WALL
95	RPM	1.02	1.03	1.09	1.01	1.02	1.06	1.01	1.01	1.03
	BHP	1.06	1.08	1.29	1.04	1.06	1.20	1.02	1.02	1.08
85	RPM	1.02	1.02	1.08	1.01	1.02	1.06	1.01	1.01	1.03
	BHP	1.05	1.07	1.26	1.03	1.05	1.18	1.02	1.02	1.08
75	RPM	1.01	1.02	1.07	1.01	1.02	1.05	1.00	1.01	1.02
	BHP	1.04	1.06	1.23	1.03	1.05	1.16	1.01	1.02	1.07
65	RPM	1.01	1.02	1.06	1.01	1.01	1.04	1.00	1.01	1.02
	BHP	1.04	1.06	1.19	1.03	1.04	1.14	1.01	1.02	1.06
55	RPM	1.01	1.02	1.05	1.01	1.01	1.04	1.00	1.01	1.02
	BHP	1.03	1.05	1.16	1.02	1.03	1.12	1.01	1.02	1.05
45	RPM	1.01	1.01	1.04	1.01	1.01	1.03	1.00	1.00	1.01
	BHP	1.02	1.04	1.13	1.02	1.03	1.09	1.01	1.01	1.04

Table 6. WOV Factors

FAN SIZE	WOV FACTOR	D
121	1.08	12.40
141	1.55	13.98
161	2.22	15.75
181	3.42	17.72
201	4.68	19.68
221	6.58	22.05
251	9.37	24.80
281	14.31	27.95
321	20.47	31.50
351	31.51	35.43
391	43.24	39.37
441	60.73	44.09
491	84.44	49.21

Table 7. Temperature and Altitude Correction Factors

AIR TEMP °F	ALTITUDE IN FEET ABOVE SEA LEVEL											
	0	1000	2000	3000	4000	5000	6000	7000	8000	9000	10000	15000
	BAROMETRIC PRESSURE IN INCHES OF MERCURY											
	29.92	28.86	27.82	26.82	25.84	24.90	23.98	23.09	22.22	21.39	20.58	16.89
70	1.000	0.964	0.930	0.896	0.864	0.832	0.801	0.772	0.743	0.714	0.688	0.564
100	0.946	0.912	0.880	0.848	0.818	0.787	0.758	0.730	0.703	0.676	0.651	0.534
150	0.869	0.838	0.808	0.770	0.751	0.723	0.696	0.671	0.646	0.620	0.598	0.490
200	0.803	0.774	0.747	0.720	0.694	0.668	0.643	0.620	0.596	0.573	0.552	0.453
250	0.747	0.720	0.694	0.669	0.645	0.622	0.598	0.576	0.555	0.533	0.514	0.421
300	0.697	0.672	0.648	0.624	0.604	0.580	0.558	0.538	0.518	0.498	0.480	0.393
400	0.616	0.594	0.573	0.552	0.532	0.513	0.493	0.476	0.458	0.440	0.424	0.347
500	0.552	0.532	0.513	0.495	0.477	0.459	0.442	0.426	0.410	0.394	0.380	0.311
600	0.500	0.482	0.469	0.448	0.432	0.416	0.400	0.386	0.372	0.352	0.344	0.282
700	0.457	0.441	0.425	0.410	0.395	0.380	0.366	0.353	0.340	0.326	0.315	0.258
800	0.420	0.404	0.389	0.375	0.362	0.350	0.336	0.323	0.311	0.300	0.290	0.237
900	0.389	0.376	0.363	0.349	0.336	0.324	0.312	0.300	0.289	0.279	0.268	0.220
1000	0.363	0.350	0.338	0.325	0.314	0.302	0.291	0.280	0.270	0.259	0.250	0.205

Table 8. Derating Factors For High Temperature

TEMP. (°F)	STEEL			STAINLESS STEEL	
	CLASS II		CLASS III	CLASS II	CLASS III
	121-281	321-491			
70	1.00	1.00	1.00	1.00	1.00
200	0.99	0.97	0.97	1.00	0.98
250	0.98	0.96	0.96	1.00	0.96
300	0.97	0.95	0.95	1.00	0.94
400	0.96	0.93	0.93	1.00	0.91
500	0.93	0.90	0.90	0.97	0.87
600	0.90	0.87	0.87	0.94	0.84
700	0.88	0.84	0.84	0.90	0.80
800	0.83	0.81	0.81	0.87	0.78
1000	N/A	N/A	N/A	0.81	0.75

When operating fans at elevated temperatures, the maximum RPMs of the fan from Table 1 on page 10 must be corrected to the safe operating RPM limit for the application using the factors listed in the Table 8.

The performance tables in this catalog are based on fans handling standard air at a density of 0.075 pounds per cubic foot. This is equivalent to air at 70°F at sea level (29.92 Hg barometric pressure). When specified performance is at a density different than standard, it must be converted to the equivalent standard conditions before the fan can be selected from the performance tables. The performance data and examples in this catalog are for unshoused BFPL plug fans.

Example 1. Standard Density

Given: 17000 CFM at 3" TSP (system). Installation is a two-wall arrangement with a wheel-to-wall clearance of 7".

Step 1. Entering the performance tables we find that a 281 BFPL plug fan will deliver 17000 CFM at 3" SP operating at 1478 RPM with 11.33 BHP.

Step 2. Catalog performance must be corrected for wheel-to-wall arrangement. Determine the wheel and plenum type from the arrangements shown in Figure 1 on 11. Determine the clearance "C" based upon the closest wall. Performance will not be affected by any additional walls spaced greater than C x 3 from the wheel.

The selected 281 BFPL fan has a wheel diameter of 27.95" ("D"). Application is two walls with 7" clearance ("C"). Therefore, $C \div D = 7 \div 27.95 = 0.25$ or $\frac{1}{4}$ " which is equivalent to $D \div 4$.

Step 3. Next, determine the Percent of Wide Open Volume (% WOV) at which the fan is to operate. From Table 6 on page 11 find that the WOV factor is 15.19 for a 281 BFPL fan.

$$\% \text{ WOV} = \frac{17000 \times 100}{1478 \times 15.19} = 75.7$$

Step 4. By interpolation from Table 5 on page 11, for the two wall column of $D \div 4$ at 75.7% WOV, we find the RPM factor of 1.02 and the BHP factor of 1.05.

Corrected unshoused performance for 17000 CFM at 3" SP standard air is:

$$\begin{aligned} \text{RPM} &= 1478 \times 1.02 = 1508 \\ \text{BHP} &= 11.33 \times 1.05 = 11.90 \end{aligned}$$

Example 2. Nonstandard Density

Given: 17000 CFM at 3" TSP (system), 300°F, 4000 ft. altitude. Installation is a two-wall arrangement with a wheel-to-wall clearance of 7".

Step 1. To enter the performance tables the operating SP must be corrected to equivalent standard conditions. From Table 7 on page 11 find the correction factor of 0.604 for 300°F and 4000 feet altitude. The corrected equivalent static pressure is equal to:

$$\text{SP (Catalog)} = \frac{3" \text{ TSP (system)}}{0.604} = 5.0$$

Fan selection is then made for 17000 CFM at 5" SP. Entering the performance tables, we find that a 281 BFPL fan will deliver 17000 CFM at 1638 RPM with 17.29 BHP. It must be remembered that this BHP is cataloged at standard 70°F air at sea level.

Steps 2, 3 and 4. Continue the correction procedure with Steps 2, 3 and 4 as shown in Example 1. Wall arrangement = $D \div 4$, % WOV = 60.0, RPM = 1654, and BHP = 17.90.

PERFORMANCE COMPARISON

Model BFPL Plug Fans are designed to maximize efficiency. This is illustrated by the following chart, which compares the new BFPL Plug Fan and other manufacturers' airfoil (AF) and backward inclined (BI) fans.

CFM	SP	MANUFACTURER	RPM	BHP	SE%
23000	3.5"	Twin City BFPL	1057	16.39	77.3
		Manufacturer "A" AF	1107	16.60	76.3
		Manufacturer "A" BI	1005	17.50	72.4
		Manufacturer "B" AF	971	17.94	70.6
33000	5"	Twin City BFPL	1409	35.28	73.6
		Manufacturer "A" AF	1475	36.50	71.1
		Manufacturer "A" BI	1324	38.30	67.8
		Manufacturer "B" AF	1295	40.81	63.6

Nominal 36" Wheel Diameter

CFM	SP	MANUFACTURER	RPM	BHP	SE%
30000	2.5"	Twin City BFPL	717	15.28	77.2
		Manufacturer "A" AF	783	15.60	75.6
		Manufacturer "A" BI	713	16.50	71.5
		Manufacturer "B" AF	725	17.46	67.6
47000	4"	Twin City BFPL	1032	40.64	72.8
		Manufacturer "A" AF	1132	43.30	68.3
		Manufacturer "A" BI	1015	45.20	65.4
		Manufacturer "B" AF	1054	50.00	59.2

Nominal 44" Wheel Diameter

491 BFPL

Wheel Dia.: 49.21"

Max. BHP = 73.45 x (RPM ÷ 1000)³

CFM	1" SP		2" SP		3" SP		4" SP		5" SP		6" SP		7" SP		8" SP		9" SP		10" SP		11" SP		12" SP	
	RPM	BHP	RPM	BHP	RPM	BHP	RPM	BHP	RPM	BHP	RPM	BHP	RPM	BHP	RPM	BHP	RPM	BHP	RPM	BHP	RPM	BHP	RPM	BHP
16000	359	3.39																						
18000	368	3.65																						
20000	<u>379</u>	<u>3.98</u>																						
22000	393	4.42																						
24000	409	4.89	514	9.97																				
26000	428	5.40	523	10.47																				
28000	449	5.96	<u>535</u>	<u>11.19</u>	624	17.82																		
32000	492	7.21	563	12.95	642	19.36	719	27.24																
36000	534	8.61	598	14.90	<u>666</u>	<u>21.58</u>	736	29.21	805	38.26														
40000	576	10.30	639	17.08	696	24.36	<u>759</u>	<u>31.94</u>	822	40.71	883	50.53												
44000	616	12.17	682	19.54	731	27.24	786	35.37	<u>844</u>	<u>43.91</u>	901	53.60	<u>957</u>	<u>64.36</u>										
48000	657	14.34	725	22.25	772	30.51	819	39.26	<u>870</u>	<u>48.06</u>	923	57.43	975	67.88	1027	79.54	1078	91.82						
52000	698	16.73	767	25.23	815	34.11	856	43.20	901	52.76	<u>949</u>	<u>62.41</u>	<u>998</u>	<u>72.60</u>	1046	83.76	1094	96.10	1142	109.33				
56000	740	19.39	808	28.55	858	37.97	897	47.56	936	57.59	979	67.94	<u>1024</u>	<u>78.41</u>	<u>1070</u>	<u>89.48</u>	1115	101.38	1159	114.17				
60000	783	22.37	849	32.27	901	42.20	940	52.36	976	62.89	1013	73.72	1054	84.92	<u>1096</u>	<u>96.14</u>	<u>1138</u>	<u>107.66</u>	<u>1180</u>	<u>120.07</u>				
64000	826	25.64	889	36.24	943	46.79	<u>983</u>	<u>57.47</u>	1018	68.55	1052	79.98	1087	91.53	1126	103.58	<u>1165</u>	<u>115.43</u>						
68000	870	29.31	930	40.65	984	51.75	1026	62.99	1061	74.64	1093	86.50	1125	98.69	1159	111.19	1195	123.77						
72000	914	33.31	<u>971</u>	<u>45.37</u>	1025	57.21	1069	69.04	1104	81.09	1135	93.40	1165	106.05	1196	119.18								
76000	<u>959</u>	<u>37.79</u>	1013	50.52	1065	62.96	1110	75.33	1147	88.02	1178	100.85	1207	114.00										

Maximum RPM @ 70°F: Class II — 952 Class III —1281 Must derate for temperature and plug wall thickness.

Underlined figures indicate maximum static efficiency. Power rating (BHP) does not include transmission losses.



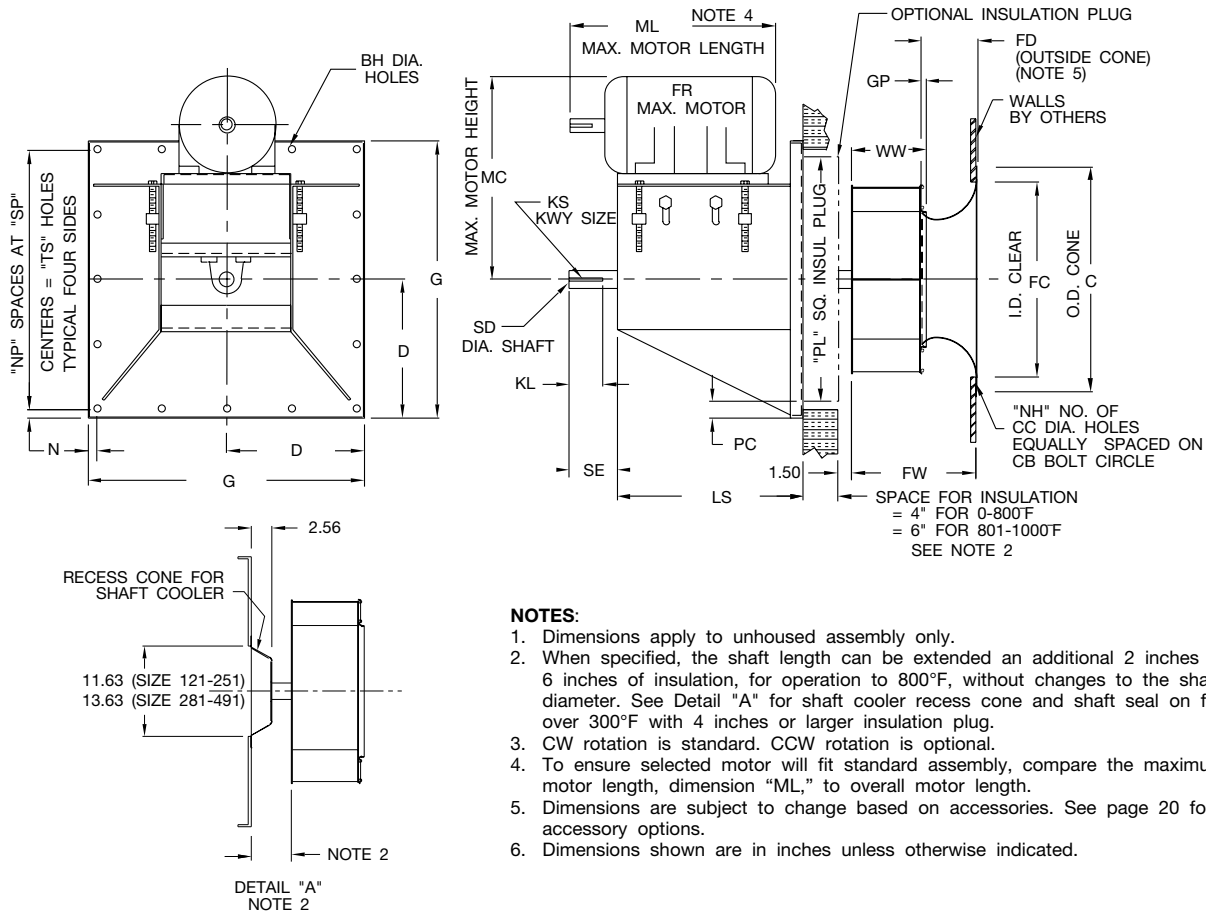

NOTES:

1. Dimensions apply to unhooused assembly only.
2. When specified, the shaft length can be extended an additional 2 inches for 6 inches of insulation, for operation to 800°F, without changes to the shaft diameter. See Detail "A" for shaft cooler recess cone and shaft seal on fans over 300°F with 4 inches or larger insulation plug.
3. CW rotation is standard. CCW rotation is optional.
4. To ensure selected motor will fit standard assembly, compare the maximum motor length, dimension "ML," to overall motor length.
5. Dimensions are subject to change based on accessories. See page 20 for accessory options.
6. Dimensions shown are in inches unless otherwise indicated.

FAN SIZE	BH	C	CB	CC	D	FC	FD	FW	G	GP	KL	KS	LS
121	0.56	17.13	15.88	0.69	11.38	13.75	3.72	8.48	22.75	0.25	4.00	.38x.19	17.50
141	0.56	18.91	17.63	0.69	11.38	15.50	4.19	9.55	22.75	0.25	4.00	.38x.19	18.50
161	0.56	20.88	19.59	0.88	14.81	17.75	4.72	10.75	29.63	0.25	4.00	.38x.19	18.50
181	0.56	22.84	21.56	0.88	14.81	20.00	5.31	12.16	29.63	0.31	4.50	.50x.25	21.00
201	0.56	25.19	23.94	0.88	14.81	22.00	5.88	13.39	29.63	0.31	4.50	.50x.25	21.00
221	0.56	27.97	26.69	0.88	16.00	24.50	6.59	15.01	32.00	0.31	4.50	.50x.25	22.50
251	0.56	31.13	29.84	1.00	16.00	27.50	7.44	16.93	32.00	0.50	4.50	.50x.25	22.50
281	0.69	34.66	33.38	1.00	18.31	30.75	8.38	19.06	36.63	0.50	5.00	.50x.25	23.00
321	0.69	39.59	37.84	1.00	21.81	35.00	9.44	21.40	43.63	0.56	5.00	.50x.25	24.50
351	0.69	43.53	41.78	1.00	21.81	39.25	10.63	24.08	43.63	0.63	5.50	.63x.31	24.50
391	0.69	48.31	46.53	1.00	27.50	43.50	11.75	26.77	55.00	0.63	5.50	.63x.31	27.50
441	0.69	53.41	51.66	1.00	27.50	48.50	13.19	29.96	55.00	0.75	5.50	.63x.31	27.50
491	0.69	59.31	57.56	1.00	28.50	54.25	14.63	33.40	57.00	0.78	5.50	.63x.31	27.50

FAN SIZE	MC	ML	N	NH	NP	PC	PL	SD	SE	SP	TS	WW	MAX. MTR. FRAME
121	24.75	19.13	1.00	8.00	4.00	1.75	19.25	1.687	5.00	5.19	20.75	5.07	213T
141	26.25	20.13	1.00	8.00	4.00	1.75	19.25	1.687	5.00	5.19	20.75	5.67	215T
161	26.25	20.13	1.00	8.00	4.00	1.81	26.00	1.687	5.00	6.91	27.63	6.34	215T
181	29.50	24.13	1.00	16.00	4.00	1.81	26.00	1.937	5.50	6.91	27.63	7.24	254T
201	29.50	24.13	1.00	16.00	4.00	1.81	26.00	1.937	5.50	6.91	27.63	7.90	254T
221	29.50	25.50	1.00	16.00	4.00	1.88	28.25	1.937	5.50	7.50	30.00	8.80	256T
251	29.50	25.50	1.00	16.00	4.00	1.88	28.25	1.937	5.50	7.50	30.00	10.06	256T
281	31.50	26.63	1.00	16.00	6.00	2.25	32.13	2.187	6.00	5.77	34.63	11.25	284T
321	33.50	28.13	1.00	16.00	6.00	2.38	38.88	2.187	6.00	6.94	41.63	12.63	286T
351	33.50	28.13	1.00	16.00	6.00	2.38	38.88	2.437	6.50	6.94	41.63	14.19	286T
391	34.00	31.25	1.00	24.00	6.00	3.38	48.25	2.437	6.50	8.83	53.00	15.75	326T
441	36.00	31.25	1.00	24.00	6.00	3.38	48.25	2.687	6.50	8.83	53.00	17.63	326T
491	36.00	31.25	1.00	24.00	6.00	2.50	52.00	2.687	6.50	9.17	55.00	19.66	326T

AC17170G

Dimensions are not to be used for construction. Certified drawings are available upon request.

Class III

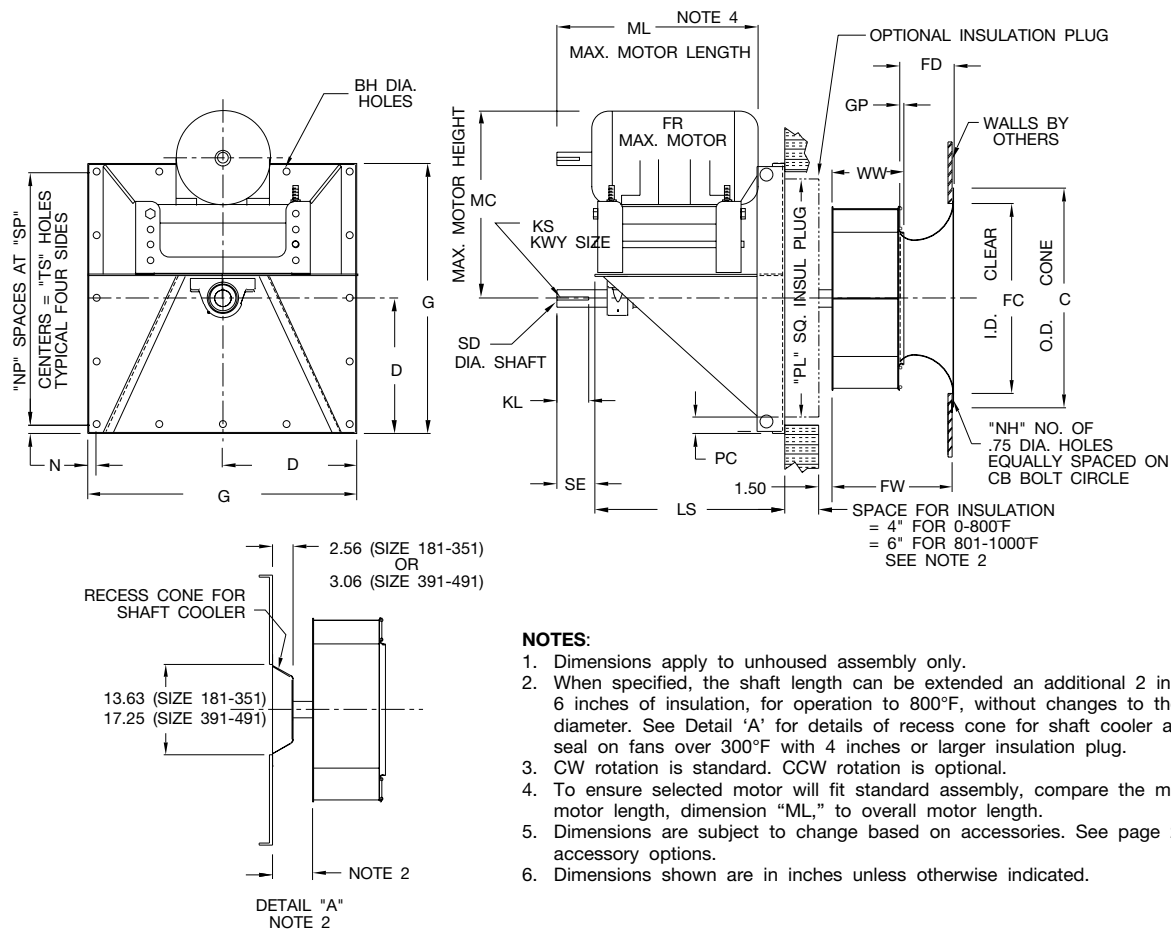

FAN SIZE	BH	C	CB	CC	D	FC	FD	FW	G	GP	KL	KS	LS
181	0.56	22.84	21.56	0.88	14.81	20.00	5.31	12.24	29.63	0.31	4.50	.63x.31	25.00
201	0.56	25.19	23.94	0.88	14.81	22.00	5.88	13.46	29.63	0.31	5.50	.63x.31	27.50
221	0.56	27.97	26.69	0.88	16.00	24.50	6.59	15.08	32.00	0.31	5.50	.63x.31	27.50
251	0.56	31.13	29.84	1.00	16.00	27.50	7.44	16.93	32.00	0.50	6.00	.63x.31	30.50
281	0.69	34.66	33.38	1.00	18.31	30.75	8.38	19.12	36.63	0.50	6.00	.63x.31	30.63
321	0.69	39.59	37.84	1.00	21.81	35.00	9.44	21.46	43.63	0.56	6.50	.63x.31	32.38
351	0.69	43.53	41.78	1.00	21.81	39.25	10.63	24.15	43.63	0.63	8.00	.63x.31	37.88
391	0.69	48.31	46.53	1.00	27.50	43.50	11.75	26.83	55.00	0.63	8.00	.75x.38	38.38
441	0.69	53.41	51.66	1.00	27.50	48.50	13.19	30.09	55.00	0.75	8.00	.88x.44	38.38
491	0.69	59.31	57.56	1.00	28.50	54.25	14.63	33.46	57.00	0.78	8.00	.88x.44	38.38

FAN SIZE	MC	ML	N	NH	NP	PC	PL	SD	SE	SP	TS	WW	MAX. MTR. FRAME
181	26.50	25.75	1.00	16.00	4.00	1.81	26.00	2.687	4.50	6.91	27.63	7.31	256T
201	28.00	28.88	1.00	16.00	4.00	1.81	26.00	2.687	5.50	6.91	27.63	7.97	284T
221	28.00	28.88	1.00	16.00	4.00	1.88	28.25	2.687	5.50	7.50	30.00	8.88	286T
251	32.00	32.00	1.00	16.00	4.00	1.88	28.25	2.687	6.00	7.50	30.00	10.06	324T
281	32.00	32.00	1.00	16.00	6.00	2.25	32.13	2.687	6.00	5.77	34.63	11.31	326T
321	34.00	34.38	1.00	16.00	6.00	2.38	38.88	2.687	6.50	6.94	41.63	12.69	365T
351	38.00	41.25	1.00	16.00	6.00	2.38	38.88	2.687	8.00	6.94	41.63	14.25	405T
391	38.00	41.25	1.00	24.00	6.00	3.38	48.25	2.937	8.00	8.83	53.00	15.81	405T
441	38.00	41.25	1.00	24.00	6.00	3.38	48.25	3.437	8.00	8.83	53.00	17.75	405T
491	38.00	41.25	1.00	24.00	6.00	2.50	52.00	3.437	8.00	9.17	55.00	19.72	405T

AC17171G

Dimensions are not to be used for construction. Certified drawings are available upon request.

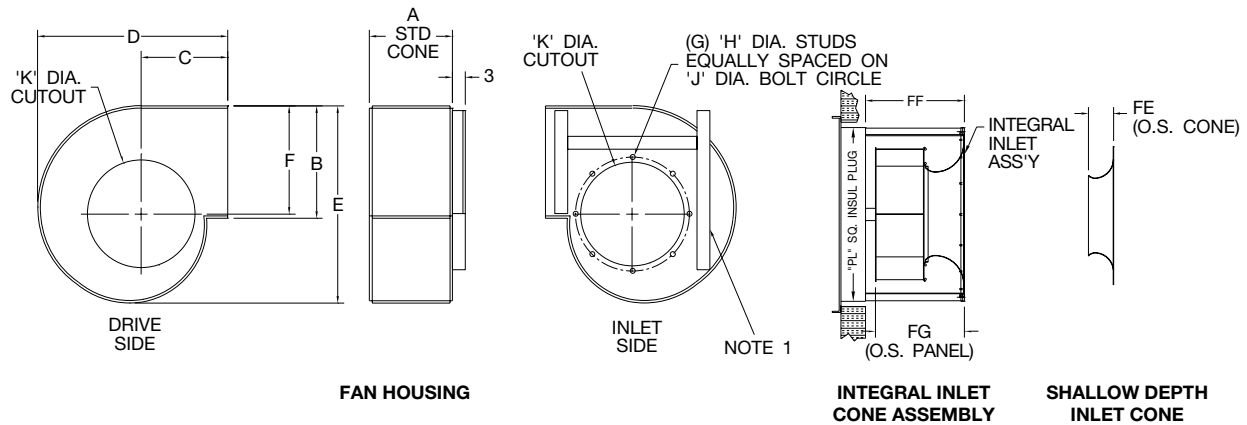

NOTES:

1. Inlet side frame angle on sizes 391, 441 and 491 only.
2. Dimensions shown are in inches unless otherwise indicated.

FAN SIZE	A	B	C	D	E	F	G	H
121	10.00	13.81	12.56	25.13	23.69	13.19	8	3/8-16
141	11.00	15.63	13.69	27.88	26.69	14.88	8	3/8-16
161	12.19	17.56	14.81	30.81	30.00	16.75	8	3/8-16
181	13.63	19.75	16.13	34.13	33.75	18.81	16	3/8-16
201	14.88	22.00	17.50	37.50	37.50	20.88	16	3/8-16
221	16.44	24.69	19.00	41.38	42.06	23.44	16	3/8-16
251	18.38	27.75	20.81	45.94	47.25	26.31	16	3/8-16
281	20.44	31.25	23.94	52.25	53.25	29.63	16	3/8-16
321	22.81	35.19	26.44	58.38	59.88	33.38	16	3/8-16
351	25.50	39.56	29.44	65.31	67.38	37.50	16	3/8-16
391	28.13	43.94	29.56	69.44	74.88	41.69	24	1/2-13
441	31.25	49.25	32.63	77.25	83.88	46.69	24	1/2-13
491	34.69	54.94	35.88	85.69	93.50	52.06	24	1/2-13

FAN SIZE	J	K	FE		FF		FG	
			STANDARD INLET CONE	SHALLOW INLET CONE	STANDARD INLET CONE	SHALLOW INLET CONE	STANDARD INLET CONE	SHALLOW INLET CONE
121	15.88	14.13	3.75	—	10.19	—	8.69	—
141	17.63	15.94	4.19	—	11.19	—	9.69	—
161	19.59	17.88	4.75	3.44	12.38	11.06	10.88	9.56
181	21.56	19.88	5.31	3.75	13.81	12.25	12.31	10.75
201	23.94	22.19	5.88	4.13	15.06	13.31	13.56	11.81
221	26.69	25.00	6.63	4.50	16.63	14.56	15.13	13.06
251	29.84	28.13	7.44	4.88	18.56	15.94	17.06	14.44
281	33.38	31.69	8.38	5.19	20.63	17.44	19.13	15.94
321	37.84	35.63	9.44	5.50	23.06	19.13	21.56	17.63
351	41.78	39.56	10.63	6.50	25.69	21.56	24.19	20.06
391	46.53	44.31	11.75	7.25	28.38	23.88	26.88	22.38
441	51.66	49.44	13.19	8.25	31.44	26.50	29.94	25.00
491	57.56	55.31	14.63	9.25	34.94	29.56	33.44	28.06

AC17172E

Dimensions are not to be used for construction. Certified drawings are available upon request.

Belt Centers

MOTOR FRAME SIZE	CLASS II								CLASS III											
	121-161		181-251		281-351		391-491		181		201-221		251-281		321		351-391		441-491	
	MIN	MAX	MIN	MAX	MIN	MAX	MIN	MAX	MIN	MAX	MIN	MAX	MIN	MAX	MIN	MAX	MIN	MAX	MIN	MAX
56	13	16.5	14	17.5	14.5	18	16	19.5	9.4	13.4	9.4	13.4	9.3	13.3	9.3	13.3	9.3	13.3	9.8	13.8
143-145	13	16.5	14	17.5	14.5	18	16	19.5	9.4	13.4	9.4	13.4	9.3	13.3	9.3	13.3	9.3	13.3	9.8	13.8
182-184	14	17.5	15	18.5	15.5	19	17	20.5	10.4	14.4	10.4	14.4	10.3	14.3	10.3	14.3	10.3	14.3	10.8	14.8
213-215	14.8	18.3	15.8	19.3	16.3	19.8	17.8	21.3	11.2	15.2	11.2	15.2	11	15	11.1	15.1	11.1	15.1	11.6	15.6
254-256	—	—	16.8	20.3	17.3	20.8	18.8	22.3	14.8	18.8	14.8	18.8	14.6	18.6	14.7	18.7	14.7	18.7	15.2	19.2
284-286	—	—	—	—	18.0	21.5	19.5	23	—	—	15.6	19.6	15.4	19.4	15.4	19.4	15.4	19.4	15.9	19.9
324-326	—	—	—	—	—	—	20.5	24	—	—	—	—	17.6	22.6	17.6	22.6	17.6	22.6	18.1	23.1
364-365	—	—	—	—	—	—	—	—	—	—	—	—	—	—	18.6	23.6	18.6	23.6	19.1	24.1
404-405	—	—	—	—	—	—	—	—	—	—	—	—	—	—	—	—	20.8	25.8	21.3	26.3



Baking Oven Application



TYPICAL SPECIFICATIONS



Model BFPL

Fans shall be Model BFPL Single Thickness Airfoil, as manufactured by Twin City Fan & Blower, Minneapolis, Minnesota.

PERFORMANCE — Fans shall be tested and rated in accordance with industry accepted test codes and shall be guaranteed by the manufacturer to deliver rated published performance levels.

PLUG PANEL — Plug panel shall be of minimum 7 gauge steel with formed flanges to maintain flatness and rigidity. Panel shall be prepunched for bolt mounting. The "Cross Frame" bearing support shall be designed for maximum stability and load spreading. Bearings shall be serviceable without disassembly of panel or frame. Plug assembly is available for both horizontal and vertical application. Horizontal construction is standard. Vertical construction must be specified.

WHEEL — BFPL wheels shall be backward curved, non-overloading, single thickness airfoil type, designed for maximum efficiency and quiet operation. Wheels shall be constructed of heavy-gauge steel, welded to a flat wheel cone and backplate.

SHAFT — Shafts shall be AISI 1040 or 1045 hot rolled steel accurately turned, ground, polished and ring gauged for accuracy. Shafts shall be sized for a first critical speed of at least 1.43 times the maximum speed for the class.

BEARINGS — Bearings shall be either ball or spherical roller, heavy-duty, self-aligning, pillow block type. Bearing selection is based upon L-10 minimum life of 40,000 hours or L-50 minimum life of 200,000 hours.

OPTIONAL ALL WELDED HOUSING — Housing shall be of heavy-gauge steel. Housing shall be provided with wheel opening on each side and weld studs on inlet side for cone mounting. Specify rotation and discharge as viewed from drive side to ensure proper stud placement. Housing supports and attachments for wall mounting to be provided by others.

ADJUSTABLE MOTOR BASE — Adjustable motor base is standard and shall have a four point leveling and tension adjustment to ensure proper drive belt alignment. The motor base shall be heavy-gauge steel and prepunched to accept standard motor frame specified.

OPTIONAL INLET VANES — Inlet vane blades are cantilever design or with centered supports equipped with permanently lubricated needle bearings and ball joints for smooth and easy operation. Vane assemblies are external type for sizes 121 through 161 and nested for sizes 181 through 491. Standard inlet vanes are applicable to 300°F. Consult factory for higher temperatures.

FACTORY RUN TEST — All fans prior to shipment shall be completely assembled and test run as a unit at the specified operating speed or maximum RPM allowed for the particular construction type. Each wheel shall be statically and dynamically balanced in accordance with ANSI/AMCA 204-96 "Balance Quality and Vibration Levels for Fans" to Fan Application Category BV-3, Balance Quality Grade G6.3. Balance readings shall be taken by electronic type equipment in the axial, vertical and horizontal directions on each of the bearings. Records shall be maintained and a written copy shall be available upon request.

GUARANTEE — The manufacturer shall guarantee the workmanship and materials for its BFPL Single Thickness Airfoil Plug Fans for at least one (1) year from startup or eighteen (18) months from shipment, whichever occurs first.

Model

BEPL (High Efficiency Plug Fans)

Sizes

12" to 49" wheel diameters (305 mm to 1,245 mm)

Performance

Airflow to 76,000 CFM (129,100 m³/hour)
Static pressure to 12" w.g. (2,980 Pa)

Features

SWSI backward curved, non-overloading, single thickness airfoil type wheels



See Catalog 355 for more information

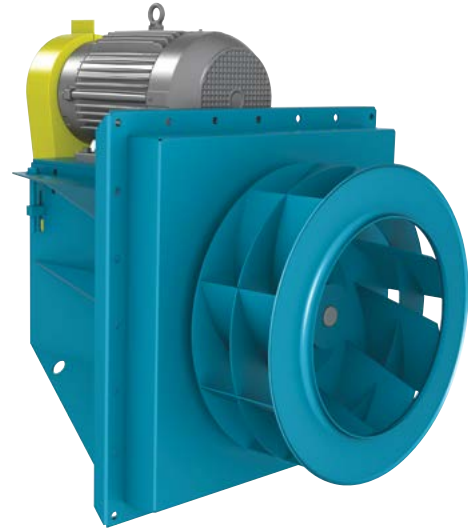

BEPL Arrangement 9 – Plug Fan

Model

BCPL (Plug Fans)

Sizes

12.25" to 49" wheel diameters (311 mm to 1,245 mm)

Performance

Airflow to 57,900 CFM (98,400 m³/hour)
Static pressure to 8" w.g. (1,990 Pa)

Features

SWSI flat-blade backward inclined, non-overloading wheels



See Catalog 350 for more information

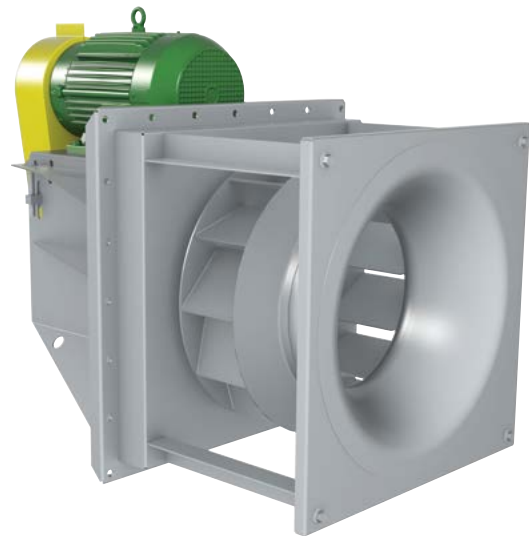

BCPL Shown with Optional Integral Inlet Cone Assembly

INDUSTRIAL PROCESS AND COMMERCIAL VENTILATION SYSTEMS

CENTRIFUGAL FANS | UTILITY SETS | PLENUM & PLUG FANS | INLINE CENTRIFUGAL FANS
MIXED FLOW FANS | TUBEAXIAL & VANEAXIAL FANS | PROPELLER WALL FANS | PROPELLER ROOF VENTILATORS
CENTRIFUGAL ROOF & WALL EXHAUSTERS | CEILING VENTILATORS | GRAVITY VENTILATORS | DUCT BLOWERS
RADIAL BLADED FANS | RADIAL TIP FANS | HIGH EFFICIENCY INDUSTRIAL FANS | PRESSURE BLOWERS
LABORATORY EXHAUST FANS | FILTERED SUPPLY FANS | MANCOOLERS | FIBERGLASS FANS | CUSTOM FANS



TWIN CITY FAN & BLOWER
WWW.TCF.COM

5959 TRENTON LANE N | MINNEAPOLIS, MN 55442 | PHONE: 763-551-7600 | FAX: 763-551-7601

©2020 Twin City Fan Companies, Ltd., Minneapolis, MN. All rights reserved. Catalog illustrations cover the general appearance of Twin City Fan & Blower products at the time of publication and we reserve the right to make changes in design and construction at any time without notice.