



INDUSTRIAL PROCESS AND  
COMMERCIAL VENTILATION SYSTEMS

# FORWARD CURVED INLINE DUCT BLOWERS

DBS (Single) | DBT (Twin)



# Duct Blowers

## General Information

Twin City Fan's belt driven DBS (single) and DBT (twin) duct blowers are specifically designed for duct applications handling relatively clean air, including supply, exhaust and return air systems. These fans offer high efficiency and quiet operation in a compact design that can be mounted in bottom horizontal or top horizontal positions. Duct collars are provided for easy mounting connections. The units can be easily serviced through access panels without removing duct connections.

Duct blowers feature forward curved centrifugal wheels which produce high air volumes at low speeds. All wheels are statically and dynamically balanced. Units are manufactured under strict quality assurance standards to ensure cataloged performance and years of trouble-free operation.

## Capabilities

DBS and DBT fans are each available in 8 sizes, ranging from 8" through 20" wheel diameters.

Performance capabilities include a broad capacity range from 400 to 31,500 CFM and static pressure capabilities to 4 inches w.g.

## Construction Features

- Housing assembly features heavy-gauge galvanized steel construction. Housing sides and scroll are spot welded on sizes 8"-18". Size 20" housing is lock seam design.
- Duct collars provide ready attachment to ductwork.
- Removable side panels provide easy access for service and maintenance without the need to remove duct connections. Complete removal of the power assembly is also possible through side access panels.
- Forward curved, galvanized steel wheels are statically and dynamically balanced to assure long life and quiet operation.
- Heavy-duty cast iron adjustable pulleys to permit speed variation.
- All models are furnished with deep groove, self aligning ball bearings, permanently lubricated and sealed.



Model DBS

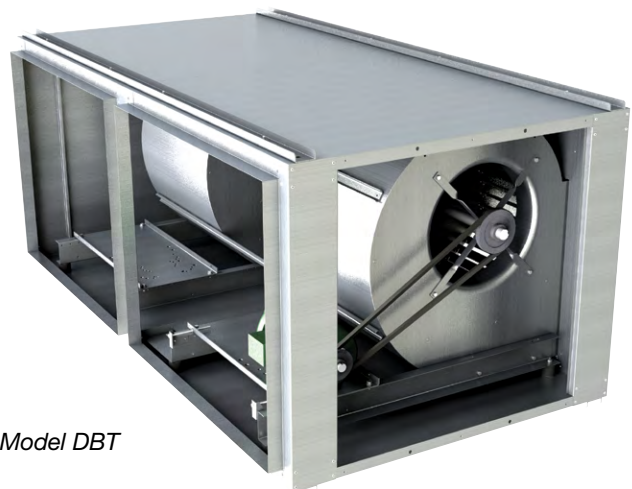

Model DBT



Twin City Fan & Blower certifies that the DBS and DBT models shown herein are licensed to bear the AMCA Seal. The ratings shown are based on tests and procedures performed in accordance with AMCA Publication 211 and AMCA Publication 311 and comply with the requirements of the AMCA Certified Ratings Program.



All DBS and DBT models are UL/cUL 705 listed, for electrical, File No. E158680.



# Construction Features

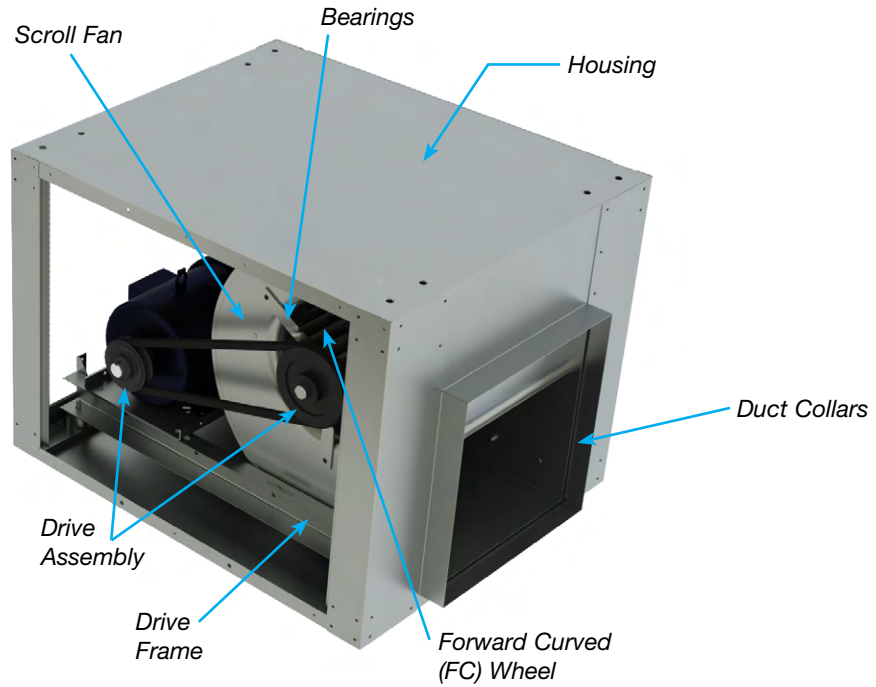

## Wheel Construction

Double width, double inlet forward curved centrifugal fan wheels are constructed of galvanized steel with FC blades tab locked into the end rings and a heavy duty steel hub is bolted to the wheel.

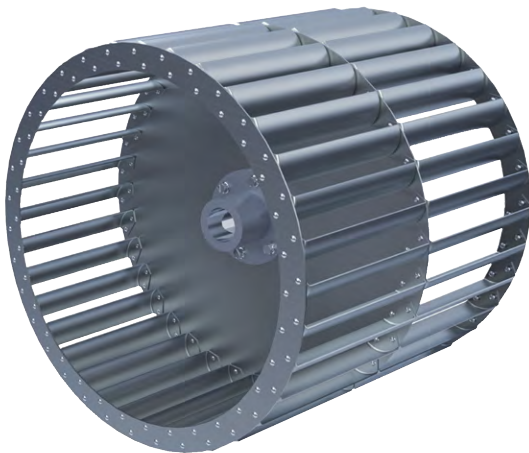

## Bearings

Deep groove, self aligning ball bearings are permanently lubricated and sealed. The bearing is mounted inside a rubber isolator and attached directly to the fan housing with a three prong (sizes 8-12) or a four prong (sizes 14-20) mount. Twin blowers (DBT) have three bearings.



# Accessories

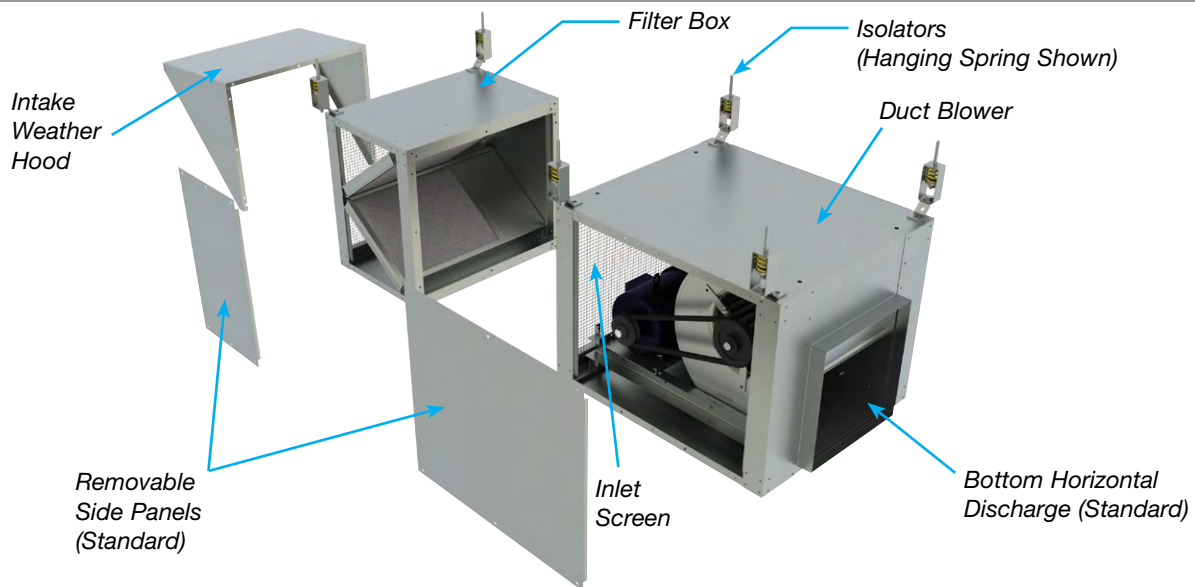

## Backdraft Dampers

Backdraft dampers, with automatic or motorized operation, feature felt-edged damper blades for quiet operation. Damper frames are constructed of 20-gauge galvanized steel and blades are constructed of 26-gauge aluminum. Dampers are channel frame and ship loose for field mounting in duct work.

Motorized dampers are recommended for low CFM applications to assure unrestricted airflow. Motorized dampers are available with 115, 208, 230, 460 or 575 volt service; 575 volt service requires a step-down transformer.

## Filter Box

A filter box containing two inch wire mesh, removable and washable filters is available for attachment to the fan inlet side. The filter box is constructed of galvanized steel, with duct collars for easy mounting and removable side panels for easy filter cleaning or replacement. Disposable paper filters are also available. One inch filters are available on either type. For filter box pressure drops contact factory. See page 21 for dimensional data.

## Multiple Discharge Positions

Models DBS and DBT are built with the fan outlet in a bottom horizontal discharge (BHD) position as standard. Units can be built with a top horizontal discharge (THD) position for installations which require it.



Top Horizontal Discharge

## Inlet Screen

An inlet screen is available to enclose the motor and drive compartment, protecting personnel and preventing birds from gaining entry to the fan and building. Screen attaches to fan or filter box, if ordered.

## Insulated Housing

A one-inch thick layer of fiberglass insulation on the interior of the fan housing is available to provide protection against condensation and to aid in noise reduction. Neoprene coated or foil face insulation is available.

## Intake Weather Hood

Intake hoods are available to keep rain and snow from entering the building. Hood includes a galvanized bird-screen, which mounts to fan housing at inlet or to filter box, if ordered.

## Disconnect Switches

NEMA-rated switches are available for positive electrical shutoff of the fan and the protection of service personnel. Switches can be shipped loose or mounted and wired.

## Vibration Isolators

Spring or neoprene type vibration isolators are available for ceiling suspension or floor mounting.

## Special Coatings

Duct blowers often require special coatings for protective and decorative purposes. Available coatings include air-dried enamel, air-dried epoxy, and Heresite (air-dried phenolic). Contact your Twin City Fan representative for more information on available coatings and colors.

# Performance Data - DBS (Single)

## 080 DBS

CFM	OV	STATIC PRESSURE (INCHES W.G.)																			
		0.125"		0.25"		0.375"		0.50"		0.625"		0.75"		1.00"		1.25"		1.50"		1.75"	
		RPM	RPM	RPM	RPM	RPM	RPM	RPM	RPM	RPM	RPM	RPM	RPM	RPM	RPM	RPM	RPM	RPM	RPM	RPM	RPM
BHP	Sone	BHP	Sone	BHP	Sone	BHP	Sone	BHP	Sone	BHP	Sone	BHP	Sone	BHP	Sone	BHP	Sone	BHP	Sone	BHP	Sone
400	519	475																			
		0.02	1.6																		
500	649	512																			
		0.03	2.0																		
600	779	556		682																	
		0.04	3.0	0.06	3.8																
700	909	602		721		825															
		0.06	3.8	0.08	4.2	0.10	5.4														
800	1039	646		763		860		951													
		0.08	4.7	0.10	5.1	0.13	5.8	0.15	6.9												
900	1169	691		810		900		983		1064											
		0.10	5.6	0.14	6.0	0.16	6.4	0.19	7.3	0.22	8.4										
1000	1299	740		855		944		1023		1097		1170									
		0.14	6.5	0.17	6.8	0.20	7.3	0.23	7.8	0.26	8.7	0.29	9.7								
1100	1429	790		899		991		1065		1137		1204		1338							
		0.17	7.5	0.21	7.8	0.25	8.1	0.28	8.7	0.31	9.3	0.35	10.2	0.42	11.9						
1200	1558	842		944		1036		1111		1178		1243		1364		1493					
		0.22	8.3	0.26	8.9	0.30	9.1	0.34	9.8	0.37	10.1	0.41	10.5	0.48	12.5	0.56	14.9				
1300	1688	895		991		1081		1158		1223		1284		1401		1512					
		0.27	9.7	0.31	10.0	0.36	10.2	0.40	10.8	0.44	11.1	0.48	11.6	0.56	13.2	0.63	15.2				
1400	1818	949		1039		1125		1203		1270		1329		1441		1546		1650			
		0.32	10.8	0.37	11.2	0.42	11.7	0.47	11.9	0.52	12.2	0.56	12.8	0.64	13.9	0.72	15.8	0.81	17.6		
1500	1948	1004		1089		1170		1247		1316		1375		1483		1585		1682		1779	
		0.39	11.8	0.44	12.7	0.49	12.9	0.55	13.2	0.60	13.5	0.65	14.0	0.74	15.0	0.83	16.7	0.92	18.0	1.01	19.7
1600	2078	1060		1140		1217		1291		1361		1422		1527		1626		1719			
		0.47	13.1	0.52	13.9	0.58	14.2	0.63	14.4	0.69	14.7	0.74	15.4	0.84	16.5	0.94	17.4	1.03	18.8		
1700	2208	1116		1192		1266		1336		1405		1467		1573		1667					
		0.55	14.1	0.61	15.2	0.67	15.7	0.73	15.9	0.79	16.1	0.85	16.4	0.96	17.4	1.06	18.5				
1800	2338	1173		1245		1315		1382		1449		1511		1619							
		0.65	15.4	0.71	16.5	0.77	17.0	0.83	17.5	0.90	17.6	0.96	17.8	1.08	19.0						
1900	2468	1230		1299		1366		1431		1493		1555									
		0.76	16.6	0.82	18.2	0.89	18.4	0.95	18.6	1.02	18.9	1.09	19.4								

## 090 DBS

CFM	OV	STATIC PRESSURE (INCHES W.G.)																			
		0.125"		0.25"		0.375"		0.50"		0.625"		0.75"		1.00"		1.25"		1.50"		1.75"	
		RPM	RPM	RPM	RPM	RPM	RPM	RPM	RPM	RPM	RPM	RPM	RPM	RPM	RPM	RPM	RPM	RPM	RPM	RPM	RPM
BHP	Sone	BHP	Sone	BHP	Sone	BHP	Sone	BHP	Sone	BHP	Sone	BHP	Sone	BHP	Sone	BHP	Sone	BHP	Sone	BHP	Sone
600	622	445																			
		0.03	2.3																		
725	752	468		608																	
		0.05	3.0	0.08	4.2																
850	882	496		630		736															
		0.07	4.0	0.10	4.7	0.13	5.9														
975	1011	530		652		761		848		926											
		0.09	5.1	0.13	5.3	0.16	6.3	0.20	7.7	0.23	8.8										
1100	1141	568		677		781		874		951		1017									
		0.12	6.2	0.16	6.4	0.20	6.9	0.24	8.2	0.28	9.3	0.32	10.3								
1225	1271	610		707		804		894		977		1047									
		0.16	7.3	0.20	7.4	0.24	7.7	0.29	8.6	0.34	9.7	0.38	11.0								
1350	1400	654		741		830		916		997		1071		1191							
		0.20	8.5	0.24	8.7	0.29	9.0	0.34	9.2	0.39	10.3	0.45	11.5	0.54	13.7						
1475	1530	699		778		860		941		1018		1091		1222		1323					
		0.26	9.6	0.30	10.1	0.35	10.1	0.40	10.3	0.46	10.9	0.51	12.2	0.63	14.4	0.73	16.7				
1600	1660	745		818		893		968		1042		1112		1244		1356		1446			
		0.32	10.7	0.36	11.4	0.42	11.6	0.47	11.9	0.53	12.0	0.59	12.4	0.72	15.2	0.84	17.6	0.94	19.6		
1725	1789	792		860		928		998		1068		1136		1263		1380		1478		1561	
		0.39	12.0	0.44	12.7	0.49	13.0	0.55	13.4	0.61	13.5	0.68	13.7	0.81	15.8	0.94	18.4	1.07	21	1.18	22
1850	1919	839		904		966		1031		1097		1161		1285		1400		1505		1593	
		0.47	13.3	0.53	13.8	0.58	14.4	0.64	14.7	0.71	15.0	0.77	15.6	0.91	16.3	1.05	18.6	1.20	21	1.33	23
1975	2049	887		948		1006		1067		1128		1189		1308		1420		1526		1621	
		0.57	14.3	0.62	15.3	0.68	16.0	0.74	16.4	0.81	16.5	0.88	17.3	1.02	17.7	1.17	19.5	1.33	22	1.48	24
2100	2178	936		994		1049		1104		1162		1220		1333		1442		1545		1643	
		0.68	15.8	0.74	16.8	0.80	17.2	0.86	18.0	0.93	18.1	1.00	19.0	1.15	19.5	1.31	21	1.47	23	1.64	24
2225	2308	984		1040		1092		1144		1197		1252		1360		1466		1566			
		0.79	16.9	0.86	18.3	0.92	18.9	0.99	19.7	1.06	20	1.13	20	1.29	21	1.45	22	1.62	23		
2350	2438	1033		1086		1137		1185		1235		1287		1389		1491					
		0.93	18.3	1.00	19.6	1.07	21	1.13	21	1.20	22	1.28	22	1.44	23	1.61	24				
2475	2567	1083		1133		1182		1228		1275		1323		1421							
		1.08	19.5	1.15	21	1.22	22	1.29	23	1.36	23	1.44	24	1.61	25						

**NOTES:**

1. Performance certified is for Installation Type B: Free inlet, ducted outlet.
2. Power rating (BHP) does not include transmission losses.
3. Performance ratings do not include the effects of appurtenances (accessories).



# Performance Data - DBS (Single)

## 100 DBS

CFM	OV	STATIC PRESSURE (INCHES W.G.)																				
		0.125"		0.25"		0.375"		0.50"		0.625"		0.75"		1.00"		1.25"		1.50"		1.75"		
		RPM	BHP	Sone	RPM	BHP	Sone	RPM	BHP	Sone	RPM	BHP	Sone	RPM	BHP	Sone	RPM	BHP	Sone	RPM	BHP	Sone
800	669	409		531																		
		0.05	2.6	0.08	4.1																	
960	803	432		557		648																
		0.07	3.6	0.11	4.5	0.14	5.8															
1120	937	461		576		675		750														
		0.10	4.8	0.14	5.0	0.18	6.3	0.22	7.5													
1280	1071	495		599		695		778		843												
		0.13	5.8	0.17	6.0	0.22	6.8	0.27	8.0	0.32	9.3											
1440	1205	533		625		715		798		871		930										
		0.17	7.0	0.22	7.2	0.27	7.4	0.33	8.5	0.38	9.8	0.43	10.9									
1600	1339	573		655		738		817		891		957		1063								
		0.23	8.2	0.27	8.4	0.33	8.7	0.39	9.0	0.45	10.1	0.52	11.3	0.63	13.8							
1760	1473	615		688		765		839		910		977		1092		1184						
		0.29	9.6	0.34	9.8	0.40	10.0	0.46	10.3	0.53	10.6	0.60	12.0	0.73	14.3	0.85	16.4					
1920	1607	658		725		795		864		932		996		1115		1212		1296				
		0.37	10.8	0.42	11.1	0.48	11.3	0.55	11.6	0.62	11.8	0.69	12.6	0.85	14.9	0.98	17.3	1.12	19.4			
2080	1741	702		764		827		892		955		1017		1133		1238		1324		1401		
		0.45	12.1	0.51	12.4	0.58	12.7	0.65	12.9	0.72	13.5	0.80	13.8	0.96	15.8	1.12	18.1	1.27	20	1.41	22	
2240	1874	746		805		862		922		982		1041		1153		1257		1351		1428		
		0.56	13.4	0.62	13.8	0.69	14.2	0.76	14.8	0.84	15.0	0.92	15.3	1.09	16.3	1.26	18.5	1.44	21	1.59	23	
2400	2008	791		846		899		955		1011		1066		1175		1276		1371				
		0.68	14.5	0.74	15.5	0.81	15.7	0.89	16.0	0.97	16.5	1.05	17.1	1.23	17.5	1.41	19.4	1.60	22			
2560	2142	836		889		939		989		1042		1094		1198		1296						
		0.81	16.0	0.88	17.1	0.96	17.5	1.03	17.8	1.12	18.4	1.20	18.6	1.39	19.2	1.58	20					
2720	2276	881		932		979		1026		1075		1125		1222								
		0.96	17.1	1.04	18.3	1.11	19.2	1.19	19.5	1.28	19.7	1.37	20	1.56	21							
2880	2410	927		975		1021		1065		1110		1157										
		1.13	18.4	1.21	20	1.30	21	1.38	21	1.46	22	1.56	23									
3040	2544	974		1019		1063		1105														
		1.32	20	1.40	21	1.49	22	1.58	23													
3200	2678	1020		1064																		
		1.53	21	1.62	23																	

## 120 DBS

CFM	OV	STATIC PRESSURE (INCHES W.G.)																				
		0.125"		0.25"		0.375"		0.50"		0.75"		1.00"		1.25"		1.50"		1.75"		2.00"		
		RPM	BHP	Sone	RPM	BHP	Sone	RPM	BHP	Sone	RPM	BHP	Sone	RPM	BHP	Sone	RPM	BHP	Sone	RPM	BHP	Sone
1000	537	294																				
		0.04	2.0																			
1220	655	304		412																		
		0.06	2.3	0.09	4.0																	
1440	773	320		416		504																
		0.08	3.0	0.12	4.3	0.17	5.8															
1660	891	342		426		507		582														
		0.11	3.6	0.15	4.8	0.20	6.1	0.25	7.2													
1880	1009	367		440		514		584		714												
		0.14	4.4	0.19	5.4	0.24	6.5	0.30	7.7	0.43	9.6											
2100	1127	394		458		526		591		713												
		0.18	5.3	0.23	6.1	0.29	6.8	0.35	8.0	0.49	10.1											
2320	1245	420		480		541		601		716		823										
		0.24	6.3	0.29	6.9	0.35	7.5	0.41	8.3	0.56	10.3	0.71	12.3									
2540	1363	446		505		558		615		722		824		920								
		0.30	7.3	0.36	7.6	0.42	8.4	0.48	8.8	0.63	10.7	0.79	12.8	0.97	12.8							
2760	1481	473		532		579		630		732		828		921		1008						
		0.37	8.5	0.44	8.4	0.50	9.1	0.57	9.7	0.72	11.3	0.89	13.4	1.07	13.4	1.26	16.7					
2980	1600	501		558		604		649		744		836		924		1008		1089				
		0.45	9.6	0.52	9.7	0.59	9.9	0.66	10.7	0.82	11.6	1.00	13.7	1.19	13.7	1.38	16.7	1.59	18.7			
3200	1718	529		585		630		670		759		846		930		1011		1089		1164		
		0.54	10.7	0.63	10.6	0.70	11.0	0.77	11.9	0.94	12.7	1.12	14.2	1.31	14.2	1.52	17.7	1.73	19.0	1.95	21	
3420	1836	559		611		656		695		775		858		938		1016		1091		1164		
		0.65	11.6	0.74	11.9	0.82	12.3	0.90	12.6	1.07	13.8	1.25	14.4	1.45	14.4	1.66	17.8	1.88	19.7	2.11	21	
3640	1954	588		637		683		720		794		872		949		1023		1096				
		0.77	12.5	0.87	13.2	0.96	13.5	1.04	13.9	1.21	15.0	1.40	15.4	1.61	15.4	1.82	18.8	2.05	19.9			
3860	2072	618		664		709		747		815		888		962		1033						
		0.91	13.7	1.01	14.6	1.11	14.7	1.20	14.9	1.37	16.0	1.57	16.8	1.78	16.8	2.00	18.8					
4080	2190	649		691		735		774		838		906		976		1044						
		1.07	14.6	1.16	15.6	1.27	16.0	1.38	16.5	1.55	17.4	1.75	17.9	1.97	17.9	2.19	19.5					
4300	2308	679		719		761		800		864		926		992								
		1.23	15.6	1.34	17.3	1.45	17.7	1.56	17.7	1.76	18.9	1.96	19.6	2.18	19.6							

**NOTES:**

1. Performance certified is for Installation Type B: Free inlet, ducted outlet.
2. Power rating (BHP) does not include transmission losses.
3. Performance ratings do not include the effects of appurtenances (accessories).

# Performance Data - DBS (Single)

## 140 DBS

CFM	OV	STATIC PRESSURE (INCHES W.G.)																				
		0.25"		0.50"		0.75"		1.00"		1.25"		1.50"		1.75"		2.00"		2.25"		2.75"		
		RPM	BHP	Sone	RPM	BHP	Sone	RPM	BHP	Sone	RPM	BHP	Sone	RPM	BHP	Sone	RPM	BHP	Sone	RPM	BHP	Sone
1800	773	385																				
		0.15	5.4																			
2100	902	397																				
		0.19	6.0	0.32	8.9																	
2400	1031	414																				
		0.25	6.8	0.38	9.4	0.54	11.9															
2700	1160	434																				
		0.32	7.4	0.46	9.8	0.63	12.3	0.81	14.5													
3000	1289	455																				
		0.40	8.4	0.55	10.5	0.72	12.8	0.92	15.4	1.13	17.9											
3300	1418	479																				
		0.50	9.8	0.66	11.3	0.84	13.6	1.04	15.9	1.26	18.3	1.49	20									
3600	1546	504																				
		0.62	10.9	0.79	12.4	0.98	14.1	1.18	16.3	1.41	19.0	1.64	21	1.90	22							
3900	1675	529																				
		0.75	12.4	0.93	13.3	1.13	15.2	1.35	17.0	1.57	19.4	1.82	21	2.08	24	2.36	25					
4200	1804	557																				
		0.90	13.7	1.10	14.6	1.31	16.3	1.53	18.0	1.77	20	2.02	22	2.28	24	2.56	26	2.86	28			
4500	1933	586																				
		1.08	15.2	1.30	16.1	1.50	17.2	1.74	19.0	1.99	21	2.25	23	2.51	25	2.80	27	3.09	28	3.73	28	
4800	2062	616																				
		1.29	16.3	1.51	17.3	1.73	18.3	1.97	20	2.23	22	2.50	23	2.77	25	3.06	27	3.36	29	4.01	29	
5100	2191	646																				
		1.51	17.9	1.74	19.0	1.98	19.8	2.23	21	2.49	23	2.77	24	3.06	26	3.35	28	3.66	30	4.32	30	
5400	2320	678																				
		1.78	19.1	2.01	21	2.26	21	2.52	23	2.79	24	3.07	25	3.38	27	3.68	28	3.99	30	4.65	30	
5700	2448	709																				
		2.06	20	2.29	22	2.57	23	2.84	24	3.11	25	3.41	27	3.71	28	4.03	30	4.35	31	5.02	31	
6000	2577	741																				
		2.38	21	2.62	24	2.91	25	3.20	26	3.47	26	3.77	28	4.09	29	4.42	30	4.75	32	5.44	32	
6300	2706	774																				
		2.74	23	2.97	25	3.27	26	3.58	27	3.87	28	4.17	29	4.50	30	4.83	32	5.17	32			

## 160 DBS

CFM	OV	STATIC PRESSURE (INCHES W.G.)																				
		0.25"		0.50"		0.75"		1.00"		1.25"		1.50"		1.75"		2.00"		2.25"		2.75"		
		RPM	BHP	Sone	RPM	BHP	Sone	RPM	BHP	Sone	RPM	BHP	Sone	RPM	BHP	Sone	RPM	BHP	Sone	RPM	BHP	Sone
2700	931	354																				
		0.25	6.2	0.41	9.5																	
3100	1069	370																				
		0.32	7.0	0.50	10.1	0.70	12.5															
3500	1206	389																				
		0.42	7.9	0.61	10.5	0.82	13.3	1.05	15.5													
3900	1344	410																				
		0.54	9.1	0.73	11.3	0.96	13.8	1.20	16.2	1.47	18.5											
4300	1482	432																				
		0.67	10.8	0.88	12.4	1.12	14.4	1.37	16.9	1.65	18.6	1.95	21									
4700	1620	455																				
		0.83	12.4	1.06	13.4	1.30	15.5	1.57	17.4	1.85	19.7	2.16	22	2.49	24							
5100	1758	480																				
		1.02	13.9	1.27	14.6	1.52	16.1	1.80	18.2	2.09	20	2.41	22	2.74	25	3.09	27	3.46	28			
5500	1896	506																				
		1.24	15.3	1.50	15.9	1.77	17.2	2.06	19.0	2.37	21	2.68	23	3.02	25	3.39	27	3.75	29			
5900	2034	534																				
		1.50	16.6	1.78	17.5	2.05	18.6	2.35	20	2.67	22	3.00	24	3.35	26	3.71	28	4.09	30	4.90	34	
6300	2172	562																				
		1.79	18.2	2.08	18.9	2.38	19.9	2.68	22	3.01	23	3.36	25	3.71	27	4.09	29	4.47	30	5.30	34	
6700	2310	591																				
		2.12	19.4	2.41	21	2.73	22	3.05	23	3.39	24	3.75	26	4.11	28	4.49	30	4.90	32			
7100	2447	621																				
		2.49	21	2.79	23	3.12	23	3.46	24	3.81	25	4.17	27	4.55	29	4.95	30	5.36	32			
7500	2585	651																				
		2.91	23	3.19	24	3.56	25	3.91	26	4.27	27	4.65	29	5.04	30	5.46	32					
7900	2723	681																				
		3.36	24	3.66	26	4.05	25	4.42	28	4.78	29	5.17	30									
8300	2861	711																				
		3.86	25	4.18	28	4.55	29	4.96	29	5.36	31											
8700	2999	742																				
		4.43	27	4.74	29	5.12	30															

**NOTES:**

1. Performance certified is for Installation Type B: Free inlet, ducted outlet.
2. Power rating (BHP) does not include transmission losses.
3. Performance ratings do not include the effects of appurtenances (accessories).

# Performance Data - DBS (Single)

## 180 DBS

CFM	OV	STATIC PRESSURE (INCHES W.G.)																			
		0.25"		0.50"		0.75"		1.00"		1.25"		1.50"		1.75"		2.00"		2.25"		2.75"	
		RPM	BHP	RPM	Sone	RPM	Sone	RPM	Sone	RPM	Sone	RPM	Sone	RPM	Sone	RPM	Sone	RPM	Sone	RPM	Sone
3000	825	299		412																	
		0.24	4.4	0.42	7.1																
3500	963	309		414		505															
		0.30	4.9	0.51	7.5	0.74	9.5														
4000	1100	323		419		506		583		656											
		0.39	5.8	0.61	8.0	0.86	10.1	1.13	11.7	1.42	13.6										
4500	1238	339		428		509		584		652		717									
		0.50	6.9	0.73	8.4	0.99	10.3	1.29	12.2	1.59	14.0	1.91	15.5								
5000	1376	356		439		515		586		652		714		773		831					
		0.63	7.9	0.88	8.9	1.15	10.9	1.45	12.9	1.78	14.6	2.12	16.3	2.47	17.6	2.85	19.3				
5500	1513	375		452		523		591		655		715		771		825		879			
		0.79	9.2	1.05	10.0	1.34	11.5	1.65	13.3	2.00	14.9	2.35	16.5	2.72	18.4	3.10	19.7	3.51	21		
6000	1651	394		468		534		598		659		717		772		824		874		972	
		0.97	10.5	1.26	11.2	1.56	12.1	1.88	13.9	2.23	15.6	2.61	17.3	2.99	18.7	3.39	20	3.80	22	4.67	25
6500	1788	414		484		547		607		666		722		775		826		875		967	
		1.17	11.9	1.49	12.3	1.81	12.9	2.14	14.5	2.51	16.1	2.90	17.6	3.30	19.5	3.72	21	4.15	22	5.03	25
7000	1926	436		501		562		618		674		728		779		829		876		967	
		1.41	13.3	1.75	13.7	2.10	13.9	2.44	14.8	2.82	16.7	3.22	18.5	3.63	19.9	4.07	22	4.51	23	5.45	26
7500	2063	457		519		578		631		684		735		785		833		880			
		1.67	14.9	2.05	15.2	2.42	15.5	2.77	15.8	3.17	17.4	3.57	18.7	4.00	21	4.45	22	4.93	24		
8000	2201	480		538		594		646		696		745		792		839		884			
		1.99	16.3	2.38	16.5	2.77	17.1	3.15	17.5	3.56	17.7	3.98	19.8	4.41	21	4.88	23	5.35	24		
8500	2338	502		558		611		662		709		756		802		846					
		2.32	18.1	2.75	18.3	3.16	18.5	3.58	18.7	3.98	19.4	4.42	19.9	4.88	22	5.34	23				
9000	2476	525		578		629		678		724		768		812							
		2.71	19.4	3.16	19.7	3.59	19.8	4.03	21	4.47	21	4.90	21	5.37	22						
9500	2613	549		599		648		695		740		782									
		3.15	21	3.60	22	4.08	22	4.53	22	4.99	22	5.44	23								
10000	2751	572		620		667		712													
		3.62	23	4.09	23	4.59	23	5.06	23												
10500	2889	596		642		687															
		4.15	24	4.63	25	5.16	26														

## 200 DBS

CFM	OV	STATIC PRESSURE (INCHES W.G.)																			
		0.25"		0.50"		0.75"		1.00"		1.25"		1.50"		2.00"		2.50"		3.00"		3.50"	
		RPM	BHP	RPM	Sone	RPM	Sone	RPM	Sone	RPM	Sone	RPM	Sone	RPM	Sone	RPM	Sone	RPM	Sone	RPM	Sone
5000	1099	293		379		456		525		590											
		0.50	6.0	0.77	8.0	1.08	10.6	1.41	12.3	1.77	14.0										
5900	1297	314		391		462		527		587		644									
		0.71	7.6	1.01	8.9	1.34	11.3	1.70	13.1	2.09	14.8	2.50	16.5								
6800	1495	338		408		472		533		590		644		743							
		0.98	9.3	1.31	10.1	1.66	12.1	2.05	13.9	2.47	15.6	2.91	17.5	3.83	21						
7700	1693	364		428		487		543		597		648		743		830		915			
		1.32	11.3	1.68	12.0	2.07	12.9	2.48	14.6	2.92	16.5	3.39	18.0	4.38	21	5.41	24	6.55	27		
8600	1891	392		451		505		557		607		655		746		831		909		986	
		1.73	13.6	2.15	14.2	2.56	14.6	3.00	15.5	3.46	17.5	3.94	19.0	4.99	22	6.11	25	7.26	28	8.50	31
9500	2089	420		475		526		574		620		666		753		834		910		982	
		2.21	15.9	2.70	16.2	3.14	16.7	3.61	16.9	4.09	18.1	4.61	20	5.71	23	6.88	26	8.10	29	9.37	32
10400	2287	450		500		549		594		637		680		762		840		913		984	
		2.81	18.3	3.33	18.5	3.84	18.7	4.33	19.5	4.84	19.9	5.39	21	6.52	24	7.75	27	9.02	30	10.39	33
11300	2485	480		527		572		616		657		696		773		848		919		987	
		3.51	20	4.07	21	4.61	21	5.17	21	5.72	22	6.26	22	7.44	25	8.72	28	10.06	31	11.47	34
12200	2682	511		555		597		639		678		716		788		859		927		993	
		4.34	23	4.92	23	5.52	23	6.12	24	6.70	25	7.31	25	8.52	26	9.84	29	11.21	32	12.69	35
13100	2880	543		584		623		662		700		736		805		872		937		1000	
		5.31	25	5.90	26	6.54	26	7.17	26	7.81	26	8.43	27	9.73	28	11.08	30	12.50	33	13.99	36
14000	3078	574		613		651		687		723		758		824		887		950		1010	
		6.37	27	6.99	29	7.71	29	8.38	29	9.05	29	9.72	29	11.08	30	12.46	31	13.97	34	15.48	37
14900	3276	606		643		678		713		747		781		845		905		964			
		7.60	29	8.25	31	8.96	32	9.72	32	10.43	32	11.16	32	12.60	33	14.04	34	15.55	35		
15800	3474	638		673		707		740		773		805		867		925					
		8.98	32	9.64	34	10.40	35	11.20	35	12.00	35	12.76	35	14.28	35	15.80	37				
16700	3672	671		704		736		768		799		829		889							
		10.56	35	11.23	38	11.98	39	12.85	38	13.69	38	14.47	38	16.09	39						
17600	3870	703		735		766		796		825		855									
		12.25	38	12.98	41	13.77	41	14.63	42	15.50	42	16.41	42								
18500	4068	736		766		796															
		14.17	41	14.89	43	15.72	44														

**NOTES:**

1. Performance certified is for Installation Type B: Free inlet, ducted outlet.
2. Power rating (BHP) does not include transmission losses.
3. Performance ratings do not include the effects of appurtenances (accessories).



# Performance Data - DBT (Twin)

## 080 DBT

CFM	OV	STATIC PRESSURE (INCHES W.G.)																			
		0.125"		0.25"		0.375"		0.50"		0.625"		0.75"		1.00"		1.25"		1.50"		1.75"	
		RPM	RPM	RPM	RPM	RPM	RPM	RPM	RPM	RPM	RPM	RPM	RPM	RPM	RPM	RPM	RPM	RPM	RPM	RPM	
BHP	Sone	BHP	Sone	BHP	Sone	BHP	Sone	BHP	Sone	BHP	Sone	BHP	Sone	BHP	Sone	BHP	Sone	BHP	Sone	BHP	Sone
800	519	483																			
		0.04	2.2																		
1000	649	523																			
		0.06	2.7																		
1200	779	569		695																	
		0.09	3.8	0.13	4.8																
1400	909	616		736		840															
		0.12	4.8	0.17	5.3	0.21	6.6														
1600	1039	662		781		878		967													
		0.17	5.9	0.22	6.2	0.27	7.1	0.32	8.3												
1800	1169	710		830		920		1004		1083											
		0.22	6.8	0.29	7.3	0.34	7.8	0.40	8.8	0.45	10										
2000	1299	761		876		967		1045		1120		1191									
		0.29	8	0.36	8.5	0.43	8.9	0.49	9.4	0.55	10.6	0.61	11.7								
2200	1429	813		922		1015		1090		1161		1228		1359							
		0.37	9.2	0.45	9.7	0.52	10.1	0.59	10.7	0.66	11.2	0.72	12.4	0.86	14						
2400	1558	867		968		1062		1138		1205		1270		1391		1513					
		0.46	10.4	0.54	10.9	0.63	11.4	0.71	12	0.78	12.4	0.86	13.1	1.00	15.4	1.16	17.9				
2600	1688	923		1018		1107		1186		1252		1313		1431		1540		1656			
		0.57	11.7	0.66	12.5	0.75	13	0.85	13.1	0.93	13.7	1.01	14.2	1.17	16.1	1.32	18.9	1.51	21		
2800	1818	979		1069		1153		1233		1301		1360		1472		1577		1679		1788	
		0.69	13.1	0.79	13.9	0.89	14.3	1.00	14.8	1.09	15	1.18	15.6	1.35	17.1	1.52	19.1	1.69	21	1.89	23
3000	1948	1036		1121		1201		1278		1348		1408		1516		1619		1715		1810	
		0.84	14.3	0.94	15.4	1.05	15.7	1.16	16.3	1.27	16.7	1.36	17.2	1.55	18.6	1.74	20	1.91	22	2.10	23
3200	2078	1094		1174		1250		1324		1394		1456		1563		1661		1755			
		1.00	15.8	1.11	17	1.22	17.4	1.34	18	1.46	18.3	1.57	18.8	1.77	19.9	1.97	21	2.16	22		
3400	2208	1152		1228		1301		1371		1439		1503		1611							
		1.18	17.4	1.30	18.6	1.42	19	1.54	19.4	1.67	20	1.79	21	2.02	22						
3600	2338	1211		1283		1353		1420		1485		1549									
		1.39	18.7	1.52	20	1.64	21	1.77	21	1.90	21	2.04	22								
3800	2468	1271		1339		1406		1470		1533											
		1.62	20	1.75	22	1.89	22	2.02	23	2.16	23										

## 090 DBT

CFM	OV	STATIC PRESSURE (INCHES W.G.)																			
		0.125"		0.25"		0.375"		0.50"		0.625"		0.75"		1.00"		1.25"		1.50"		1.75"	
		RPM	RPM	RPM	RPM	RPM	RPM	RPM	RPM	RPM	RPM	RPM	RPM	RPM	RPM	RPM	RPM	RPM	RPM	RPM	
BHP	Sone	BHP	Sone	BHP	Sone	BHP	Sone	BHP	Sone	BHP	Sone	BHP	Sone	BHP	Sone	BHP	Sone	BHP	Sone	BHP	Sone
1200	622	445																			
		0.07	3																		
1425	739	465		606																	
		0.10	3.6	0.15	5.1																
1650	856	490		626		729															
		0.13	4.8	0.19	5.5	0.25	7.1														
1875	973	519		645		755		838													
		0.17	5.8	0.24	6.1	0.31	7.6	0.38	9												
2100	1089	552		666		773		866		938											
		0.22	7	0.29	7	0.38	8	0.46	9.5	0.53	10.9										
2325	1206	589		692		792		884		966		1030									
		0.28	8.2	0.36	8.2	0.45	8.8	0.54	10	0.63	11.6	0.71	12.7								
2550	1323	627		720		814		903		985		1058		1175							
		0.36	9.3	0.44	9.4	0.53	9.9	0.63	10.6	0.73	12	0.83	13.5	1.01	16.2						
2775	1439	667		752		838		923		1003		1077		1201		1310					
		0.44	10.7	0.53	11	0.63	11.3	0.73	11.6	0.84	12.6	0.95	14	1.16	16.7	1.37	19.4				
3000	1556	708		786		866		946		1023		1095		1227		1330					
		0.55	12.1	0.64	12.3	0.74	12.5	0.85	13	0.96	13.3	1.08	14.7	1.32	17.4	1.54	20				
3225	1673	750		822		896		970		1044		1115		1246		1359		1449			
		0.67	13.4	0.76	13.8	0.87	14	0.98	14.3	1.10	14.9	1.23	15.1	1.49	18.3	1.74	21	1.96	23		
3450	1789	792		860		928		998		1067		1136		1263		1380		1478			
		0.80	14.4	0.90	15.2	1.01	15.6	1.13	16.1	1.25	16.3	1.39	16.5	1.65	18.9	1.94	22	2.19	24		
3675	1906	835		899		962		1028		1093		1158		1282		1398					
		0.95	15.6	1.06	16.6	1.17	16.9	1.30	17.5	1.42	18.1	1.56	18.3	1.84	19.5	2.14	22				
3900	2023	878		939		998		1059		1122		1183		1304							
		1.13	17.1	1.24	18.2	1.35	18.7	1.48	19.2	1.62	19.6	1.75	20	2.05	21						
4125	2140	921		980		1036		1093		1151		1210									
		1.32	18.1	1.44	19.4	1.56	20	1.69	21	1.82	21	1.97	22								
4350	2256	965		1021		1075		1128		1183											
		1.53	19.9	1.66	21	1.79	22	1.92	23	2.06	23										
4575	2373	1009		1063		1114		1165													
		1.76	21	1.90	23	2.03	24	2.17	24												

**NOTES:**

1. Performance certified is for Installation Type B: Free inlet, ducted outlet.
2. Power rating (BHP) does not include transmission losses.
3. Performance ratings do not include the effects of appurtenances (accessories).

# Performance Data - DBT (Twin)

## 100 DBT

CFM	OV	STATIC PRESSURE (INCHES W.G.)																			
		0.125"		0.25"		0.375"		0.50"		0.625"		0.75"		1.00"		1.25"		1.50"		1.75"	
		RPM	RPM	RPM	RPM	RPM	RPM	RPM	RPM	RPM	RPM	RPM	RPM	RPM	RPM	RPM	RPM	RPM	RPM	RPM	RPM
BHP	Sone	BHP	Sone	BHP	Sone	BHP	Sone	BHP	Sone	BHP	Sone	BHP	Sone	BHP	Sone	BHP	Sone	BHP	Sone	BHP	Sone
1600	669	409		531																	
		0.10	3.3	0.16	5.1																
1920	803	432		557		648															
		0.14	4.5	0.22	5.5	0.29	7														
2240	937	461		576		676		750													
		0.19	5.8	0.28	6.1	0.37	7.6	0.45	9.1												
2560	1071	495		599		695		778		843											
		0.27	7.1	0.36	7.2	0.46	8.1	0.56	9.7	0.65	11.2										
2880	1205	533		625		715		798		871		930									
		0.35	8.4	0.45	8.7	0.56	8.9	0.67	10.2	0.79	11.8	0.89	13.2								
3200	1339	573		655		738		817		891		958		1063							
		0.46	9.9	0.56	10.1	0.68	10.4	0.80	10.9	0.93	12.2	1.06	13.7	1.29	16.7						
3520	1473	615		689		765		839		910		977		1093		1184					
		0.59	11.5	0.70	11.8	0.82	12.1	0.95	12.4	1.09	12.8	1.23	14.5	1.51	17.2	1.75	19.7				
3840	1607	658		725		795		864		932		996		1115		1213		1296			
		0.75	13	0.86	13.4	0.99	13.7	1.13	14	1.27	14.2	1.42	15.1	1.73	17.9	2.02	21	2.29	23		
4160	1741	702		764		827		892		955		1017		1134		1238		1324		1401	
		0.93	14.5	1.05	14.9	1.19	15.7	1.33	15.5	1.48	16.2	1.64	16.7	1.97	18.9	2.30	22	2.61	24	2.90	27
4480	1874	746		805		862		922		981		1040		1153		1258		1351		1428	
		1.14	16.1	1.28	16.7	1.41	17.1	1.56	17.8	1.72	18.1	1.88	18.4	2.23	19.6	2.60	22	2.95	25	3.26	28
4800	2008	791		846		900		955		1011		1066		1175		1276		1371			
		1.38	17.5	1.52	18.6	1.67	18.8	1.82	19.2	1.99	19.8	2.16	20	2.52	21	2.90	23	3.29	26		
5120	2142	836		889		939		989		1042		1094		1197		1296					
		1.66	19.2	1.81	20	1.96	21	2.12	21	2.29	22	2.47	22	2.84	23	3.24	24				
5440	2276	881		932		979		1026		1075		1125		1222							
		1.96	21	2.13	22	2.29	23	2.45	23	2.63	24	2.81	24	3.20	25						
5760	2410	927		975		1021		1065		1110		1157									
		2.31	22	2.48	24	2.66	25	2.82	26	3.00	26	3.20	27								
6080	2544	973		1019		1063		1105													
		2.69	24	2.88	26	3.06	27	3.24	27												
6400	2678	1020		1064																	
		3.13	26	3.32	28																

## 120 DBT

CFM	OV	STATIC PRESSURE (INCHES W.G.)																			
		0.125"		0.25"		0.375"		0.50"		0.75"		1.00"		1.25"		1.50"		1.75"		2.00"	
		RPM	RPM	RPM	RPM	RPM	RPM	RPM	RPM	RPM	RPM	RPM	RPM	RPM	RPM	RPM	RPM	RPM	RPM	RPM	RPM
BHP	Sone	BHP	Sone	BHP	Sone	BHP	Sone	BHP	Sone	BHP	Sone	BHP	Sone	BHP	Sone	BHP	Sone	BHP	Sone	BHP	Sone
2000	537	294																			
		0.08	2.6																		
2440	655	304		412																	
		0.12	3	0.19	4.9																
2880	773	320		416		504															
		0.16	3.7	0.24	5.3	0.34	7.1														
3320	891	342		426		507		582													
		0.22	4.5	0.30	5.8	0.41	7.4	0.52	8.7												
3760	1009	367		440		514		584		714											
		0.29	5.5	0.38	6.6	0.49	7.8	0.61	9.2	0.88	11.6										
4200	1127	394		458		526		591		713											
		0.38	6.5	0.48	7.4	0.59	8.2	0.72	9.6	1.00	12.2										
4640	1245	420		480		541		601		716		823									
		0.48	7.6	0.59	8.3	0.71	9.1	0.84	9.9	1.14	12.5	1.45	14.8								
5080	1363	446		505		558		614		722		824		920							
		0.61	8.8	0.73	9.2	0.85	10.1	0.99	10.5	1.29	13	1.63	15.5	1.98	17.2						
5520	1481	473		532		579		630		732		828		921		1008					
		0.75	10.2	0.89	10.1	1.02	10.9	1.16	11.7	1.48	13.6	1.82	16	2.20	17.9	2.58	20				
5960	1600	501		558		604		649		744		836		924		1008		1089			
		0.92	11.6	1.08	11.6	1.22	12	1.36	13	1.68	14.1	2.05	16.4	2.43	18.4	2.83	20	3.25	22		
6400	1718	529		585		630		670		759		846		930		1011		1089		1164	
		1.11	13	1.29	12.8	1.44	13.3	1.58	14.4	1.92	15.2	2.29	17.1	2.69	19	3.11	21	3.54	23	3.99	25
6840	1836	559		611		656		695		775		858		938		1016		1091		1164	
		1.34	14	1.52	14.4	1.69	14.8	1.85	15.3	2.18	16.6	2.56	17.3	2.97	19.5	3.41	21	3.86	23	4.33	25
7280	1954	588		637		683		720		794		872		949		1023		1096		1166	
		1.58	15	1.78	15.8	1.97	16.1	2.13	16.7	2.48	18.1	2.87	18.6	3.29	20	3.74	22	4.21	24	4.69	26
7720	2072	618		664		709		747		815		888		961		1033		1103		1170	
		1.86	16.5	2.07	17.5	2.27	17.8	2.46	18	2.82	19.4	3.21	20	3.64	21	4.10	23	4.59	25	5.08	26
8160	2190	649		691		735		774		838		906		976		1044		1111			
		2.18	17.5	2.39	18.8	2.61	19.3	2.82	19.9	3.18	21	3.60	21	4.03	22	4.49	23	4.99	25		
8600	2308	679		719		761		800		864		926		992		1058		1122			
		2.53	18.9	2.74	21	2.98	21	3.20	21	3.61	23	4.02	24	4.46	24	4.94	24	5.43	25		

**NOTES:**

1. Performance certified is for Installation Type B: Free inlet, ducted outlet.
2. Power rating (BHP) does not include transmission losses.
3. Performance ratings do not include the effects of appurtenances (accessories).

# Performance Data - DBT (Twin)

## 140 DBT

CFM	OV	STATIC PRESSURE (INCHES W.G.)																				
		0.125"		0.25"		0.375"		0.50"		0.75"		1.00"		1.25"		1.50"		1.75"		2.00"		
		RPM	BHP	Sone	RPM	BHP	Sone	RPM	BHP	Sone	RPM	BHP	Sone	RPM	BHP	Sone	RPM	BHP	Sone	RPM	BHP	Sone
3600	773	299		385		465																
		0.20	4.6	0.30	6.6	0.42	8.8															
4175	897	319		397		469		537														
		0.28	5.6	0.39	7.2	0.51	9.1	0.65	10.8													
4750	1020	342		413		478		540		658												
		0.38	6.7	0.50	8.0	0.63	9.7	0.77	11.3	1.10	14.5											
5325	1144	366		431		491		549		658		760										
		0.50	8.1	0.63	9.0	0.77	10.5	0.92	11.8	1.26	14.9	1.64	17.4									
5900	1267	392		452		508		561		663		759										
		0.64	9.3	0.79	10.2	0.94	11.4	1.10	12.6	1.45	15.7	1.84	18.5									
6475	1391	420		474		526		576		671		762		849								
		0.82	11.0	0.98	11.8	1.13	12.4	1.30	13.7	1.67	16.3	2.07	18.6	2.52	22							
7050	1514	449		497		547		594		683		768		851		930		1005				
		1.03	12.5	1.19	13.1	1.37	13.5	1.54	14.8	1.93	17.0	2.34	19.7	2.80	22	3.29	25	3.81	27			
7625	1638	478		522		568		613		697		778		856		931		1004		1074		
		1.28	13.9	1.45	14.5	1.63	14.9	1.82	16.0	2.22	17.7	2.66	20	3.12	23	3.61	25	4.15	28	4.71	30	
8200	1761	509		547		591		633		714		790		864		936		1006		1074		
		1.57	15.1	1.73	16.1	1.94	16.6	2.14	17.0	2.56	18.9	3.01	21	3.49	24	3.99	26	4.54	28	5.11	30	
8775	1885	540		575		615		655		732		804		874		943		1010				
		1.90	16.4	2.07	17.3	2.28	18.3	2.50	18.5	2.93	20	3.40	22	3.89	24	4.42	27	4.97	29			
9350	2008	571		603		639		678		751		821		887		953		1017				
		2.27	17.3	2.45	19.0	2.66	19.8	2.90	20	3.35	22	3.84	24	4.35	26	4.90	28	5.45	30			
9925	2132	603		632		665		702		771		838		902		964						
		2.70	19.1	2.88	20	3.10	22	3.35	22	3.82	23	4.31	25	4.85	27	5.41	28					
10500	2255	634		662		692		726		793		857		919								
		3.17	20	3.36	22	3.58	23	3.84	24	4.36	25	4.86	26	5.41	28							
11075	2379	666		692		720		751		815		877										
		3.70	22	3.90	24	4.12	25	4.38	25	4.93	26	5.46	28									
11650	2502	698		723		748		777														
		4.28	24	4.50	25	4.71	27	4.98	27													
12225	2626	730		753		778																
		4.92	25	5.13	27	5.38	28															

## 160 DBT

CFM	OV	STATIC PRESSURE (INCHES W.G.)																				
		0.25"		0.50"		0.75"		1.00"		1.25"		1.50"		1.75"		2.00"		2.25"		2.75"		
		RPM	BHP	Sone	RPM	BHP	Sone	RPM	BHP	Sone	RPM	BHP	Sone	RPM	BHP	Sone	RPM	BHP	Sone	RPM	BHP	Sone
5400	931	354		477																		
		0.51	7.5	0.85	11.5																	
6250	1077	371		482		584																
		0.67	8.5	1.03	12.3	1.46	15.4															
7100	1224	391		492		586		674														
		0.88	9.7	1.27	12.9	1.70	16.2	2.20	18.6													
7950	1370	414		507		593		676		754												
		1.15	11.5	1.56	13.9	2.01	16.8	2.52	19.7	3.08	22											
8800	1517	438		524		604		681		755		826										
		1.46	13.5	1.89	15.2	2.38	17.9	2.90	20	3.48	23	4.10	25									
9650	1663	463		544		619		691		760		827		892		954						
		1.83	15.7	2.30	16.6	2.81	19.0	3.37	21	3.94	23	4.58	26	5.25	29	5.96	31					
10500	1810	490		565		636		703		768		832		894		954		1012				
		2.26	17.3	2.77	17.9	3.30	21	3.88	22	4.48	25	5.14	28	5.83	30	6.56	32	7.32	34			
11350	1956	518		588		655		719		780		840		899		956		1012		1119		
		2.77	19.3	3.32	19.9	3.87	22	4.48	23	5.12	25	5.78	28	6.48	31	7.22	34	8.00	36	9.65	40	
12200	2103	548		612		676		736		794		851		907		961		1015		1118		
		3.36	21	3.94	22	4.54	23	5.14	25	5.81	27	6.51	29	7.24	32	7.97	34	8.77	36	10.44	41	
13050	2249	578		637		697		755		811		864		917		969		1020				
		4.03	22	4.64	24	5.27	25	5.90	26	6.60	29	7.31	31	8.06	33	8.83	36	9.62	38			
13900	2396	610		662		720		776		829		880		930		980		1029				
		4.82	24	5.40	26	6.10	27	6.78	28	7.47	30	8.22	33	8.99	34	9.80	36	10.62	39			
14750	2542	641		689		744		797		848		898		946		993						
		5.67	26	6.27	28	7.02	29	7.74	30	8.44	32	9.23	34	10.04	36	10.86	38					
15600	2689	673		717		769		819		869		916										
		6.64	28	7.25	30	8.04	32	8.79	32	9.56	34	10.31	35									
16450	2835	705		746		794		843		890												
		7.71	30	8.34	32	9.14	34	9.97	35	10.75	36											
17300	2982	738		776		820																
		8.92	32	9.55	35	10.35	36															
18150	3128	771		807																		
		10.25	34	10.91	38																	

**NOTES:**

1. Performance certified is for Installation Type B: Free inlet, ducted outlet.
2. Power rating (BHP) does not include transmission losses.
3. Performance ratings do not include the effects of appurtenances (accessories).

# Performance Data - DBT (Twin)

## 180 DBT

CFM	OV	STATIC PRESSURE (INCHES W.G.)																			
		0.25"		0.50"		0.75"		1.00"		1.25"		1.50"		1.75"		2.00"		2.25"		2.75"	
		RPM	Sone	RPM	Sone	RPM	Sone	RPM	Sone	RPM	Sone	RPM	Sone	RPM	Sone	RPM	Sone	RPM	Sone	RPM	Sone
6000	825	299		412																	
		0.48	5.4	0.87	8.5																
7000	963	309		414		505															
		0.62	5.9	1.04	9.0	1.52	11.5														
8000	1100	323		419		506		583		656											
		0.81	7.0	1.25	9.6	1.76	12.1	2.31	14.1	2.91	16.3										
9000	1238	339		428		509		584		652		717									
		1.03	8.2	1.51	10.1	2.04	12.5	2.64	14.8	3.25	16.8	3.91	18.7								
10000	1376	356		439		515		586		652		714		773		831					
		1.30	9.5	1.81	10.7	2.36	13.1	2.98	15.6	3.64	17.6	4.34	19.6	5.06	21	5.83	23				
11000	1513	375		452		523		591		655		715		771		825		879			
		1.62	11.0	2.16	12.1	2.74	13.9	3.39	16.0	4.09	17.9	4.83	19.9	5.57	22	6.35	23	7.19	25		
12000	1651	394		468		534		598		659		717		772		824		874		972	
		1.99	12.7	2.59	13.5	3.19	14.6	3.86	16.7	4.58	18.8	5.34	21	6.14	22	6.95	24	7.78	26	9.57	30
13000	1788	414		484		547		607		666		722		775		826		875		967	
		2.40	14.4	3.06	14.9	3.70	15.6	4.39	17.5	5.15	19.4	5.95	21	6.77	23	7.63	25	8.51	27	10.31	30
14000	1926	436		501		562		618		674		728		779		829		876			
		2.90	16.0	3.59	16.5	4.30	16.8	5.00	17.9	5.78	20	6.60	22	7.45	24	8.35	26	9.25	28		
15000	2063	457		519		578		631		684		735		785		833		880			
		3.43	18.0	4.20	18.3	4.96	18.7	5.68	19.1	6.49	21	7.32	22	8.21	25	9.13	26	10.10	28		
16000	2201	480		538		594		646		696		745		792		839		884			
		4.08	19.6	4.88	19.9	5.67	20	6.47	21	7.29	21	8.16	24	9.03	25	10.00	27	10.98	29		
17000	2338	502		558		611		662		709		756		802		846					
		4.76	22	5.64	22	6.47	22	7.33	22	8.16	23	9.07	24	10.00	26	10.94	28				
18000	2476	525		578		629		678		724		768									
		5.55	23	6.47	23	7.36	24	8.26	25	9.15	25	10.05	25								
19000	2613	549		599		648		695		740											
		6.46	25	7.39	26	8.35	26	9.28	26	10.24	26										
20000	2751	572		620		667		712													
		7.42	27	8.37	27	9.41	28	10.38	27												
21000	2889	596		642		687															
		8.50	29	9.48	30	10.59	30														

## 200 DBT

CFM	OV	STATIC PRESSURE (INCHES W.G.)																			
		0.25"		0.50"		0.75"		1.00"		1.25"		1.50"		1.75"		2.00"		2.25"		2.75"	
		RPM	Sone	RPM	Sone	RPM	Sone	RPM	Sone	RPM	Sone	RPM	Sone	RPM	Sone	RPM	Sone	RPM	Sone	RPM	Sone
12000	1319	317		392		462		527		587		643		698							
		1.51	9.4	2.11	10.7	2.80	13.7	3.55	15.9	4.36	18.0	5.19	19.9	6.09	22						
13300	1462	334		405		470		532		589		643		694		744		793			
		1.91	11.0	2.57	11.9	3.29	14.2	4.08	16.5	4.91	18.8	5.80	21	6.71	22	7.68	24	8.71	26		
14600	1605	352		419		480		538		593		646		695		742		788		877	
		2.37	12.6	3.10	13.6	3.86	14.8	4.67	17.1	5.55	19.4	6.50	21	7.45	23	8.44	25	9.48	27	11.69	30
15900	1748	372		435		492		546		599		650		698		744		788		872	
		2.93	14.3	3.72	15.3	4.51	15.8	5.34	17.8	6.27	20	7.26	22	8.27	24	9.32	26	10.40	28	12.64	31
17200	1891	392		451		505		557		607		655		702		746		789		871	
		3.55	16.3	4.40	17.1	5.24	17.5	6.15	18.7	7.09	21	8.08	23	9.16	25	10.23	27	11.36	28	13.72	32
18500	2034	412		468		520		569		616		662		707		751		792		872	
		4.24	18.3	5.19	18.6	6.09	19.6	7.03	19.9	8.00	21	9.02	24	10.12	25	11.29	27	12.42	29	14.88	33
19800	2177	433		486		536		583		628		671		714		756		797		874	
		5.05	20	6.08	21	7.05	21	8.04	22	9.07	22	10.09	24	11.21	26	12.39	28	13.62	30	16.12	33
21100	2320	455		505		553		598		640		682		723		763		803		878	
		5.99	22	7.08	22	8.13	23	9.17	24	10.19	24	11.30	25	12.45	27	13.63	28	14.92	30	17.50	34
22400	2463	477		524		570		613		655		694		733		772		810		883	
		7.04	24	8.17	25	9.30	25	10.37	25	11.53	26	12.62	27	13.79	28	15.05	30	16.33	31	18.99	35
23700	2606	499		544		588		630		670		708		745		782		818			
		8.21	26	9.38	26	10.61	27	11.77	28	12.94	28	14.11	28	15.31	28	16.57	30	17.85	32		
25000	2748	522		565		606		646		685		722		758		793		828			
		9.54	28	10.75	29	12.01	29	13.21	29	14.45	30	15.69	30	16.95	31	18.23	31	19.57	33		
26300	2891	544		585		625		664		702		738		772							
		10.95	30	12.17	31	13.56	31	14.87	31	16.19	32	17.48	33	18.74	33						
27600	3034	567		606		644		682		718		753									
		12.55	31	13.77	33	15.20	35	16.64	35	17.97	35	19.31	35								
28900	3177	590		628		664		700		735											
		14.29	33	15.58	37	17.02	37	18.52	37	19.93	37										
30200	3320	613		650		685															
		16.18	37	17.54	39	19.05	39														
31500	3463	637		672																	
		18.31	39	19.65	41																

**NOTES:**

1. Performance certified is for Installation Type B: Free inlet, ducted outlet.
2. Power rating (BHP) does not include transmission losses.
3. Performance ratings do not include the effects of appurtenances (accessories).

# Dimensional Data

## Model DBS (Single)

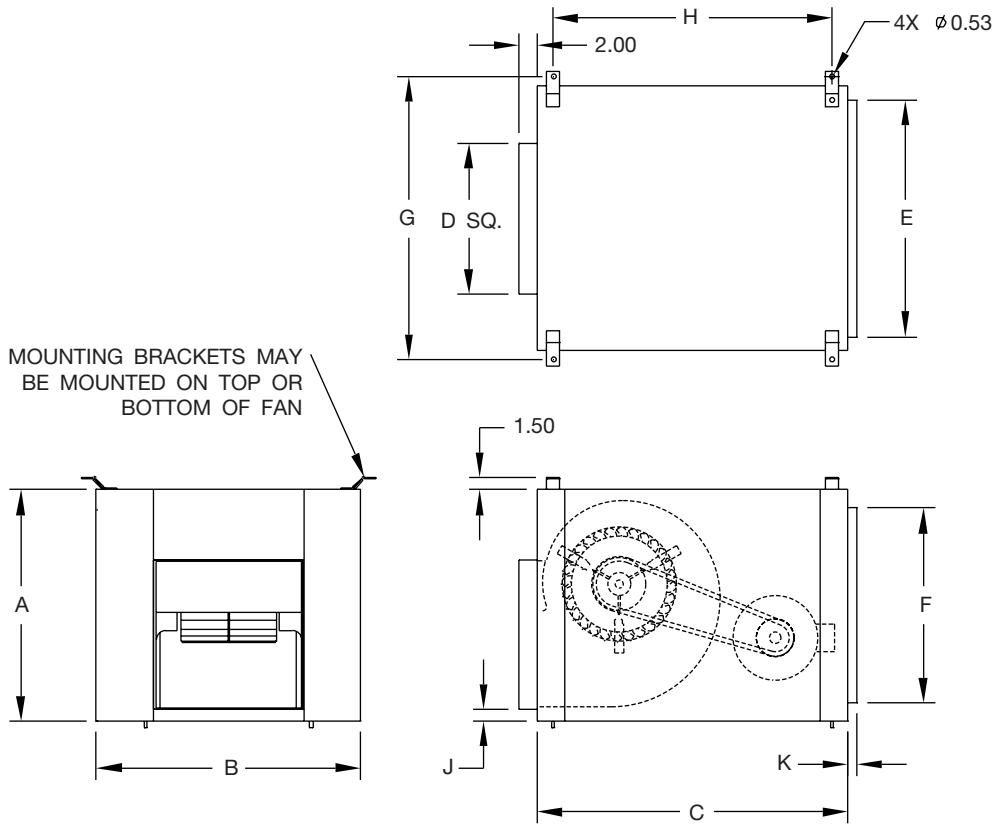

MODEL DBS	A	B	C	D SQ.	E	F	G	H	J	K	MAX FRAME	DAMPER SIZE, SQ.	AVG. SHIP WT. (LBS.)
080	16.13	18.38	23.31	10.50	15.38	13.13	20.38	20.13	1.31	1.00	145T	10.50	57
090	18.00	20.63	24.31	11.75	17.63	15.00	22.63	21.13	1.31	1.00	145T	11.75	65
100	19.69	22.25	28.31	13.06	19.25	16.69	24.25	24.88	1.31	1.00	184T	13.13	77
120	25.25	28.75	33.81	16.38	25.75	21.25	30.75	30.38	1.31	1.00	184T	16.38	129
140	27.50	32.38	34.09	18.31	28.38	23.50	34.38	30.00	1.63	1.50	184T	18.25	151
160	30.75	36.25	38.09	20.44	32.25	26.75	38.25	34.00	1.63	1.50	184T	20.44	180
180	34.88	41.00	43.09	22.88	37.00	30.88	43.00	39.00	1.63	1.50	215T	22.88	226
200	38.63	45.38	47.59	25.63	41.38	34.63	47.38	43.38	1.63	2.00	256T	25.63	261

- Notes:**
1. All figures are in inches unless noted otherwise.
  2. Average ship weight is for fan and motor assembly.
  3. Dimensions are not to be used for construction.

D-4220-1



# Dimensional Data

## Model DBT (Twin)

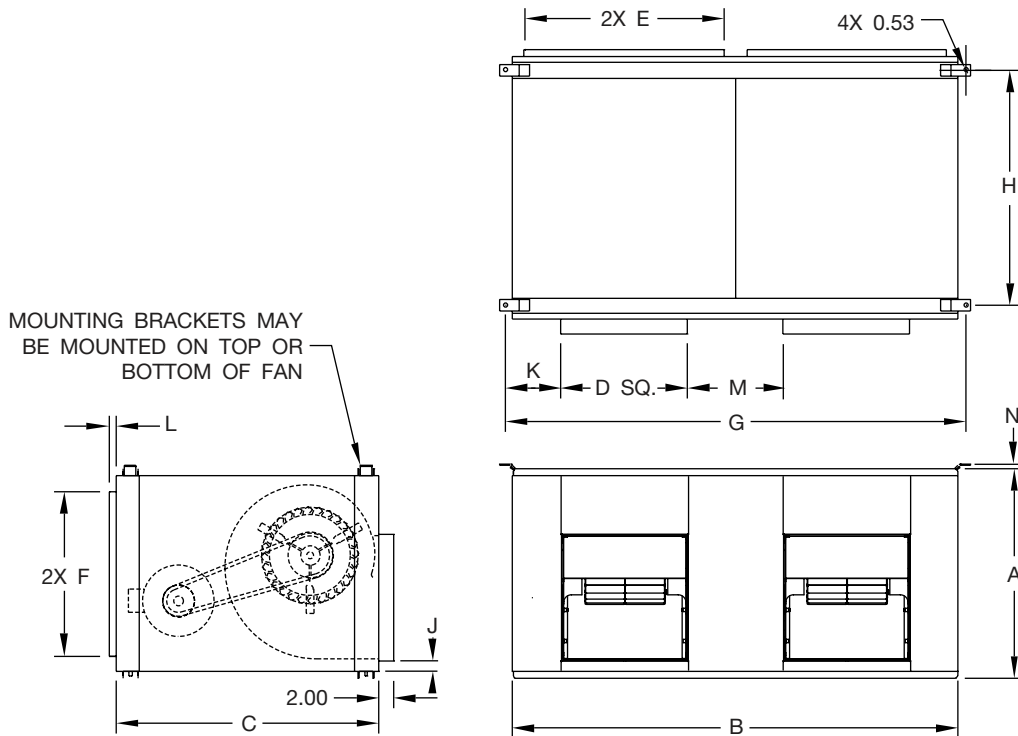

MODEL DBT	A	B	C	D SQ.	E	F	G	H	J	K	L	M	N	MAX FRAME	DAMPER SIZE, SQ.	AVG. SHIP WT. (LBS.)
080	17.63	36.63	23.31	10.50	15.38	13.13	38.63	20.13	1.31	4.00	1.00	7.75	0.75	145T	10.50	97
090	19.50	41.13	24.31	11.75	17.63	15.00	43.13	21.13	1.31	4.44	1.00	8.75	0.75	145T	11.75	115
100	21.19	44.50	28.31	13.06	19.25	16.69	46.50	24.88	1.31	4.63	1.00	9.13	0.75	184T	13.13	143
120	27.00	57.50	33.81	16.38	25.75	21.25	59.50	30.38	1.31	6.25	1.00	12.38	0.63	184T	16.38	242
140	29.25	64.75	34.09	18.31	28.38	23.50	66.75	30.00	1.63	7.00	1.50	14.00	0.63	184T	18.25	270
160	32.50	72.50	38.09	20.44	32.25	26.75	74.50	34.00	1.63	8.00	1.50	15.75	0.63	215T	20.44	322
180	36.88	82.00	43.09	22.88	37.00	30.88	84.00	39.00	1.63	9.00	1.50	18.13	0.50	215T	22.88	413
200	40.63	90.75	47.59	25.63	41.38	34.63	92.75	43.38	1.63	10.00	2.00	19.75	0.50	286T	25.63	523

**Notes:**

1. All figures are in inches unless noted otherwise.
2. Average ship weight is for fan and motor assembly.
3. Dimensions are not to be used for construction.
4. Damper quantity is two.

D-4220-2

# Dimensional Data - Accessories

## Intake Weather Hood

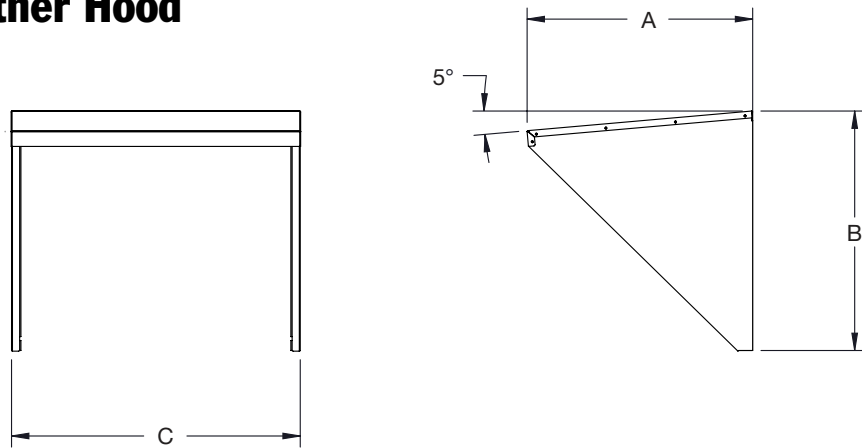

FAN SIZE	A	B	C
080	13.00	15.50	17.81
090	15.00	17.38	20.13
100	17.00	19.13	21.75
120	22.00	23.38	28.25
140	25.00	25.63	30.81
160	28.00	28.88	34.75
180	32.00	33.00	39.50
200	36.00	36.75	43.81

**Notes:**

- Quantity of two (2) hoods required for Model DBT, Twin Duct Blower.
- Includes inlet screen, which mounts to fan housing or to optional filter box, if ordered. Screen does not mount to hood.

## Backdraft Damper

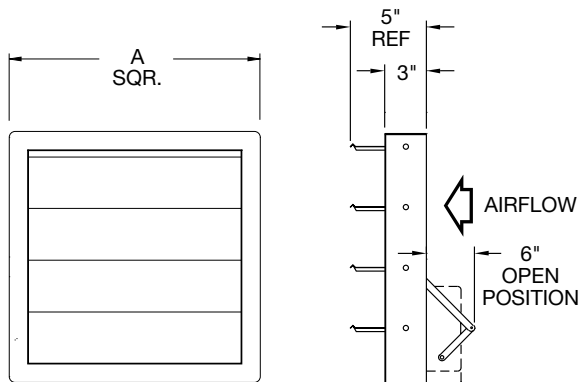

FAN SIZE	A
080	10.50
090	11.75
100	13.13
120	16.38
140	18.25
160	20.44
180	22.88
200	25.63

**Notes:**

- Quantity of two (2) dampers required for Model DBT, Twin Duct Blower.
- Available as automatic or motorized.

# Dimensional Data - Accessories

## Filter Box (Single)

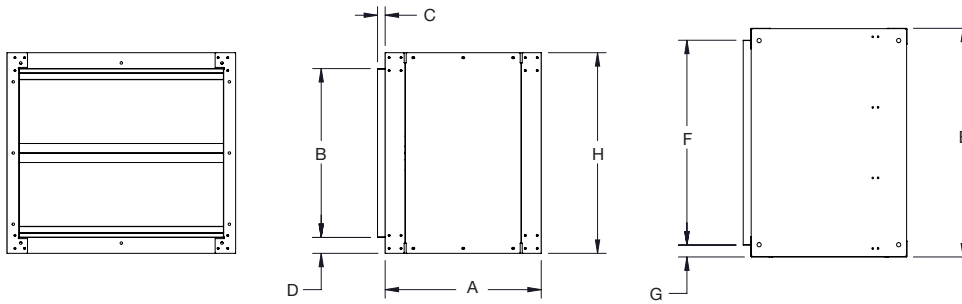

DBS SIZE	A	B	C	D	E	F	G	H	FILTER SIZE	QTY.
080	17.19	13.13	1.00	1.50	18.38	15.38	1.50	16.13	16 x 16	1
090	18.19	15.00	1.00	1.50	20.63	17.63	1.50	18.00	18 x 20	1
100	19.31	16.69	1.00	1.50	22.25	19.25	1.50	19.69	20 x 20	1
120	19.63	21.25	1.00	2.00	28.75	25.75	2.00	25.25	16 x 20	2
140	19.09	23.50	1.50	2.00	32.38	28.38	2.00	27.50	16 x 16	4
160	23.81	26.75	1.50	2.00	36.25	32.25	2.00	30.75	18 x 20	4
180	23.09	30.88	1.50	2.00	41.00	37.00	2.00	34.88	20 x 20	4
200	21.75	34.63	2.00	2.00	45.38	41.38	2.00	38.63	20 x 20	4

## Filter Box (Twin)

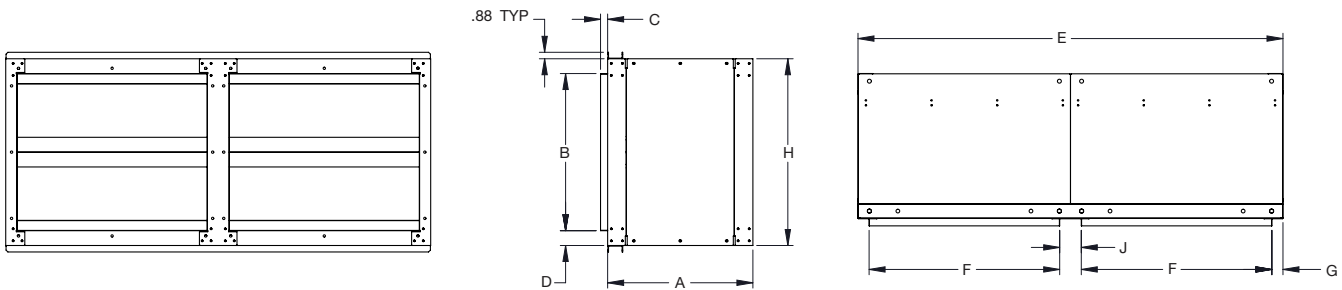

DBT SIZE	A	B	C	D	E	F	G	H	J	FILTER SIZE	QTY.
080	17.19	13.13	1.00	1.50	36.63	15.38	1.50	16.13	2.92	16 x 16	2
090	18.19	15.00	1.00	1.50	41.13	17.63	1.50	18.00	2.92	18 x 20	2
100	19.31	16.69	1.00	1.50	44.50	19.25	1.50	19.69	2.92	20 x 20	2
120	19.63	21.25	1.00	2.00	57.50	25.75	2.00	25.25	2.92	16 x 20	4
140	19.09	23.50	1.50	2.00	64.75	28.38	2.00	27.50	3.92	16 x 16	8
160	23.81	26.75	1.50	2.00	72.50	32.25	2.00	30.75	3.92	18 x 20	8
180	23.09	30.88	1.50	2.00	82.00	37.00	2.00	34.88	3.92	20 x 20	8
200	21.75	34.63	2.00	2.00	90.75	41.38	2.00	38.63	3.92	20 x 20	8

# Dimensional Data - Accessories, Assembled

## Model DBS (Single)

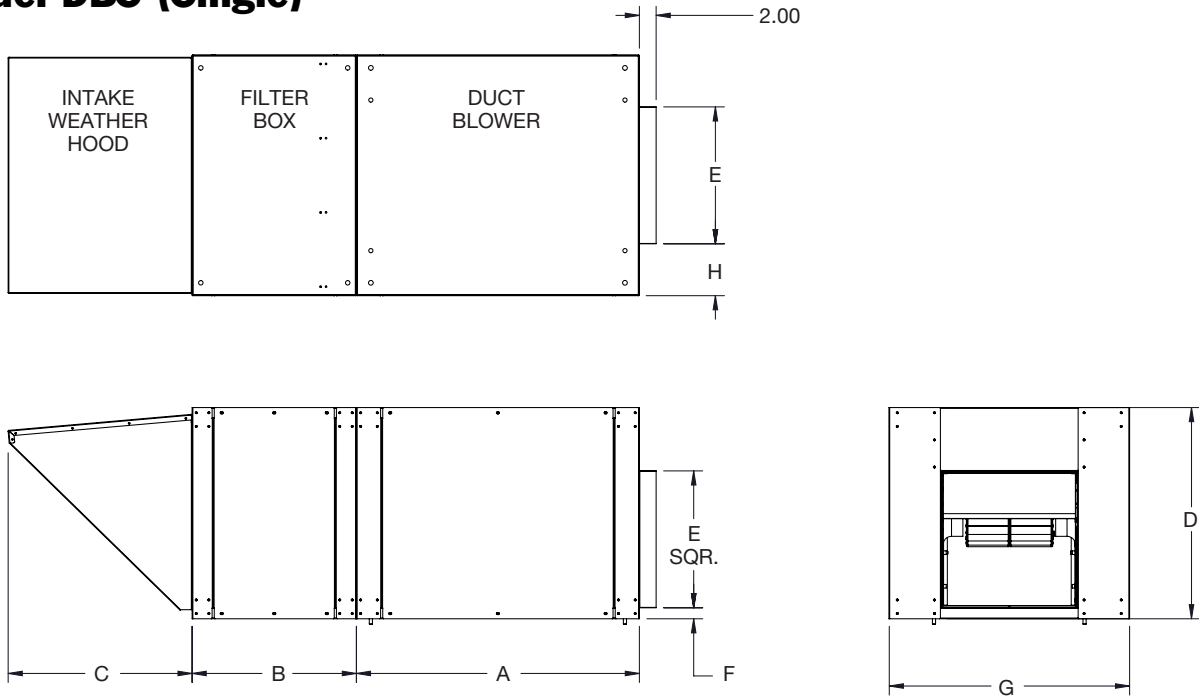

DBS	A	B	C	D	E SQR.	F	G	H
080	23.31	17.19	13.00	16.13	10.50	1.31	18.38	4.00
090	24.31	18.19	15.00	18.00	11.75	1.31	20.63	4.44
100	28.31	19.31	17.00	19.69	13.06	1.31	22.25	4.63
120	33.81	19.63	22.00	25.25	16.38	1.31	28.75	6.25
140	34.09	19.09	25.00	27.50	18.31	1.63	32.38	7.00
160	38.09	23.81	28.00	30.75	20.44	1.63	36.25	8.00
180	43.09	23.09	32.00	34.88	22.88	1.63	41.00	9.00
200	47.59	21.75	36.00	38.63	25.63	1.63	45.38	10.00

**Note:**  
Dimensions are not to be used for construction.

# Dimensional Data - Accessories, Assembled

## Model DBT (Twin)

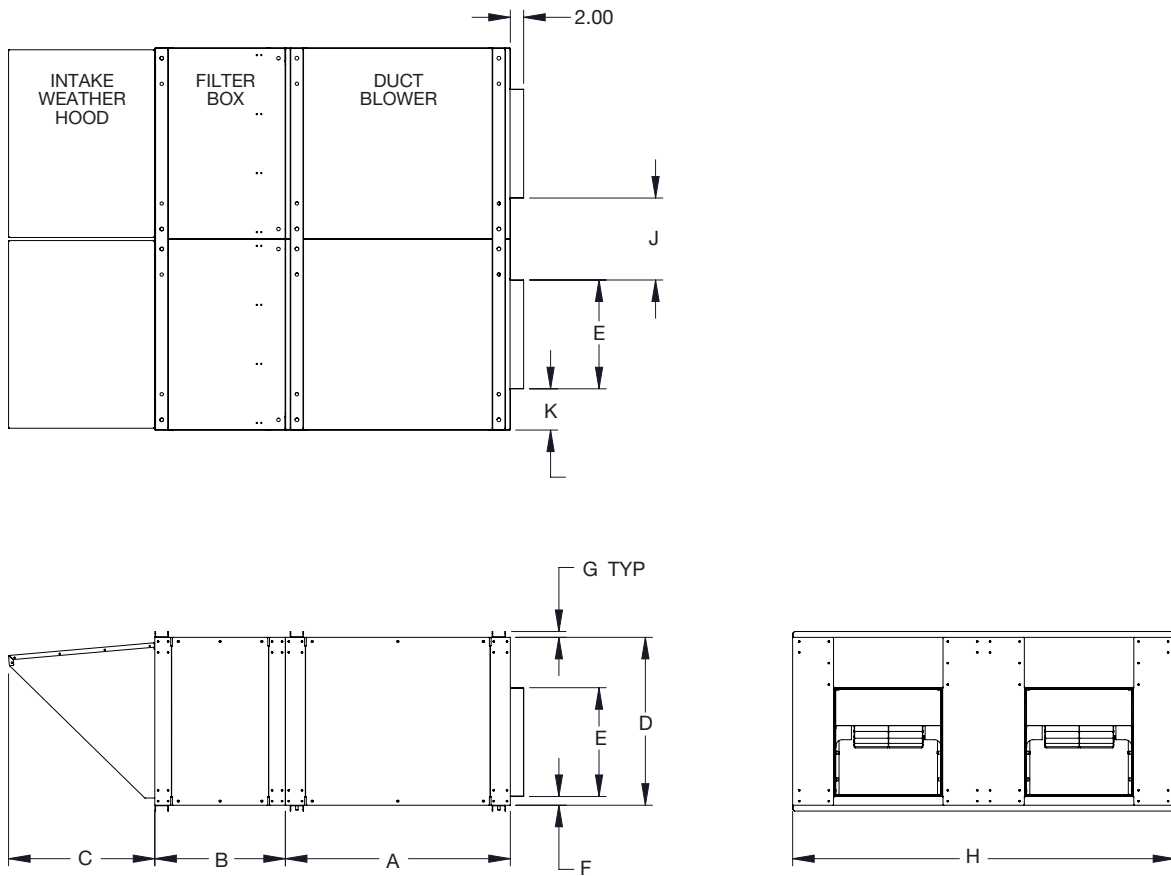

DBT	A	B	C	D	E SQR.	F	G	H	J	K
080	23.31	17.19	13.00	16.13	10.50	1.31	0.75	36.63	7.75	4.00
090	24.31	18.19	15.00	18.00	11.75	1.31	0.75	41.13	8.75	4.44
100	28.31	19.31	17.00	19.69	13.06	1.31	0.75	44.50	9.13	4.63
120	33.81	19.63	22.00	25.25	16.38	1.31	0.88	57.50	12.38	6.25
140	34.09	19.09	25.00	27.50	18.31	1.63	0.88	64.75	14.00	7.00
160	38.09	23.81	28.00	30.75	20.44	1.63	0.88	72.50	15.75	8.00
180	43.09	23.09	32.00	34.88	22.88	1.63	1.00	82.00	18.13	9.00
200	47.59	21.75	36.00	38.63	25.63	1.63	1.00	90.75	19.75	10.00

**Note:**  
Dimensions are not to be used for construction.



# Typical Specifications

---

Forward curved inline duct blowers shall be model DBS (single) or model DBT (twin) as manufactured by Twin City Fan Companies Ltd., Minneapolis, MN.

**BLOWER HOUSING** - Heavy gauge galvanized steel blower housings with removable access panels.

**FAN HOUSING** - Fan housings are constructed of galvanized steel for corrosion resistance. For fan sizes up to 18" the housing sides and scroll are spot welded together to form a durable assembly. For fan size 20" the side plates are lock formed to the scroll for a durable, air tight construction without compromising the galvanized surface coating of the metal.

**WHEEL** - Double width, double inlet fan wheels are constructed of galvanized steel, forward curve blades, tab locked into the end rings. A galvanized structural steel plate mounted in the center of the wheel supports the shaft and stabilizes the blades.

**SHAFTS** - Shafts are formed from C40 carbon steel. The shafts are ground, polished and ring gauged for accuracy. Fan assemblies are provided with coated shafts for enhanced corrosion protection. Single solid shafts are standard on all sizes.

**BEARINGS** - Deep groove, self aligning ball bearings are permanently lubricated and sealed. The bearings are mounted inside a rubber isolator and attached directly to the fan housing with a three (sizes 8-12) or four (sizes 14-20) prong mount.

**MOTORS** - All motors shall be single phase or three phase induction, permanently lubricated, heavy-duty, ball bearing type, closely matched to the fan load and provided at the voltage, phase, hertz and enclosure as provided on the fan schedule.

**DRIVES** - Motor sheaves shall be cast iron, and supplied as variable pitch standard. Drives and belts shall be rated for a minimum of 150% of the required motor HP.

**WARRANTY** - The manufacturer shall guarantee the workmanship and materials for models DBS and DBT for at least one (1) year from startup or eighteen (18) months from the date of shipment, whichever occurs first.

# INDUSTRIAL PROCESS AND COMMERCIAL VENTILATION SYSTEMS

CENTRIFUGAL FANS | UTILITY SETS | PLENUM & PLUG FANS | INLINE CENTRIFUGAL FANS  
MIXED FLOW FANS | TUBEAXIAL & VANEAXIAL FANS | PROPELLER WALL FANS | PROPELLER ROOF VENTILATORS  
CENTRIFUGAL ROOF & WALL EXHAUSTERS | CEILING VENTILATORS | GRAVITY VENTILATORS | DUCT BLOWERS  
RADIAL BLADED FANS | RADIAL TIP FANS | HIGH EFFICIENCY INDUSTRIAL FANS | PRESSURE BLOWERS  
LABORATORY EXHAUST FANS | FILTERED SUPPLY FANS | MANCOOLERS | FIBERGLASS FANS | CUSTOM FANS



**TWIN CITY FAN & BLOWER**  
[WWW.TCF.COM](http://WWW.TCF.COM)

5959 TRENTON LANE N | MINNEAPOLIS, MN 55442 | PHONE: 763-551-7600 | FAX: 763-551-7601

©2018 Twin City Fan Companies, Ltd., Minneapolis, MN. All rights reserved. Catalog illustrations cover the general appearance of Twin City Fan & Blower products at the time of publication and we reserve the right to make changes in design and construction at any time without notice.