

WBF Bladder Tank Series Installation & Operation Instructions

VESSEL DESCRIPTION: American Wheatley tanks are ASME constructed, pre-charged bladder expansion tanks. They are designed to absorb the expansion forces and control the pressure in heating/cooling systems. The system's expanded water (fully compatible with water/glycol mixtures) is contained in a heavy-duty bladder preventing tank corrosion and water logging problems. The factory set pre-charge for these tanks is 12 psig.

The tank pre-charge should be set equal to the minimum system pressure required at the point where the tank is installed.

CAUTION-If charging above 80 psi, charge to approximately 60 psi, then slowly introduce approximately 1/3 of tank water volume before SLOWLY charging up to desired pressure.

IMPORTANT: When pressure testing the system piping, the expansion tank must be isolated from the elevated pressure test. Bladder stress and premature failure may result. When filling the system with water, open valve to tank to ensure that any residual air in the tank is displaced by water. It is recommended that the pre-charge be checked annually to ensure proper system protection and long-life for the vessel.

TANK PREPARATION: Visually inspect tank for damage, which may occur during transit. Factory pre-charge pressure may not be correct for the installation. Pre-charge is typically set to equal the system pressure. If unsure, consult a factory representative. Tank **MUST** be pre-charged to system design pressure **BEFORE** placing into operation. Remove pipe plug covering the valve enclosure. Check and adjust the charge pressure by adding or releasing air for each application.

Set tank in place and pipe system connection to system. Be sure to include isolation valve and drain. Do not loosen nuts on cover plate; this will result in loss of pre-charge. Cover plate should only be removed when replacing bladder, and then only after the tank has been bled to zero gauge pressure.

If system has been filled with water and the tank has been through several cycles, the tank must be isolated from the system and the tank emptied before charging. This ensures all fluid has exited the bladder and proper charging will occur.

If the pre-charge adjustment is necessary, oil and water free compressed air or nitrogen gas may be used. Check the pre-charge using an accurate pressure gauge at the charging valve and adjust as required. Check air valve for leakage. If evident, replace the Schrader-type tire valve core. Do not depend on the valve cap to seal the leak. After making sure air charge is correct, replace protective cover over the charging valve for protection.

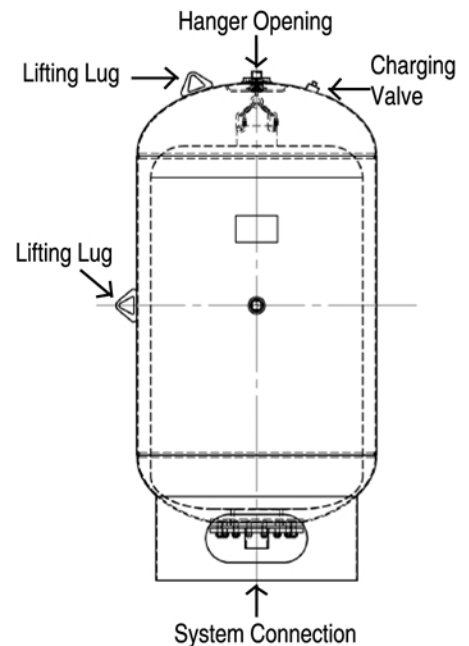

WBF 140 thru WBF 1500

JOB NAME _____
LOCATION _____

CONTRACTOR _____
CONTRACTOR P.O. NO. _____

ITEMS	QUANTITY
_____	_____
_____	_____
_____	_____
_____	_____
_____	_____

WBF Bladder Tank Series Instructions for Bladder change

RECOMMENDED TOOLS AND SUPPLIES:

- | | |
|--------------------------|-------------------|
| 1. Plumbers tool box | 5. Pressure Gauge |
| 2. Compressed air source | 6. Length of rope |
| 3. Replacement Bladder | 7. Work light |
| 4. Chain block | 8. Extension cord |
- Isolate bladder type expansion tank from system. Shut off automatic fill, valve and drain boiler to release all system pressure.
 - Bleed system air charge through air charging valve. Remove air valve core at top of the tank and discharge remaining air.
 - Disconnect tank from the system.
 - Remove bolted bottom flange. Prior to removal, mark mating flanges in order to match up properly when reassembling.
 - Open and unhook the hanger from the top of the tank.
 - Using the chain block and a slight twisting motion, slide the bladder out of the tank.
 - Clean up any remaining water, dry out the inside of the tank and clean out any remaining dirt or foreign particles. Check the inside of the tank for any sharp edges that may cut the bladder.
 - Carefully roll up the replacement bladder lengthwise, with both sides rolled toward the middle like a scroll. This insures the bladder will expand without twisting when filled. Secure at intervals with rope or cord in order to keep it rolled.
 - Drop a rope through the top hanger opening and tie it to the bladder.
 - Insert the replacement bladder, removing the rope or cord as it nears the tank opening. Many times on larger sized tanks, the bladder may be inserted more easily with the tank laying on it's side on the floor.
 - By pulling on the rope, the bladder can be pulled up into position, replace the hanger hook and remove the rope.
 - Replace the bottom flange, align the marks and tighten the bolts evenly, using a star pattern.
 - Using compressed air source and pressure gauge, apply 10 psi air pressure to the flange connection then relive pressure. These actions should ensure proper positioning of the replacement bladder within the tank.
 - Reassemble the air valve at the top and seal the hanger opening.
 - Precharge tank to fill-pressure or minimum operating pressure.
 - Using soapy water, check the air valve, hanger plug and bottom flange joint for leakage.
 - Reconnect the system, open the fill-valve and check operation of the tank. Always precharge tank before completing this step.

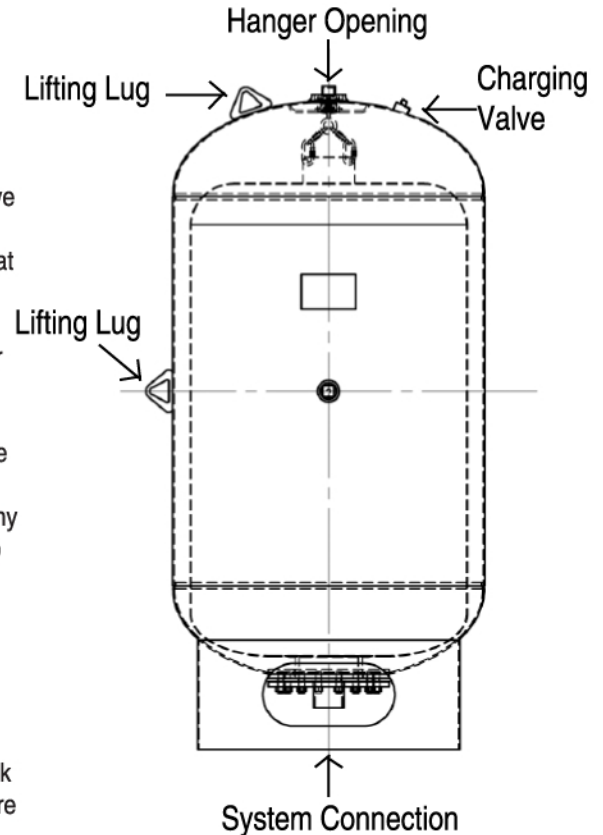

WBF 140 thru WBF 15000

JOB NAME _____
LOCATION _____

CONTRACTOR _____
CONTRACTOR P.O. NO. _____

ITEMS	QUANTITY
_____	_____
_____	_____
_____	_____
_____	_____
_____	_____