



INDUSTRIAL PROCESS AND
COMMERCIAL VENTILATION SYSTEMS

MODULAR PLENUM FANS

MPQN | MPQS



PLENUM FANS



Inlet View

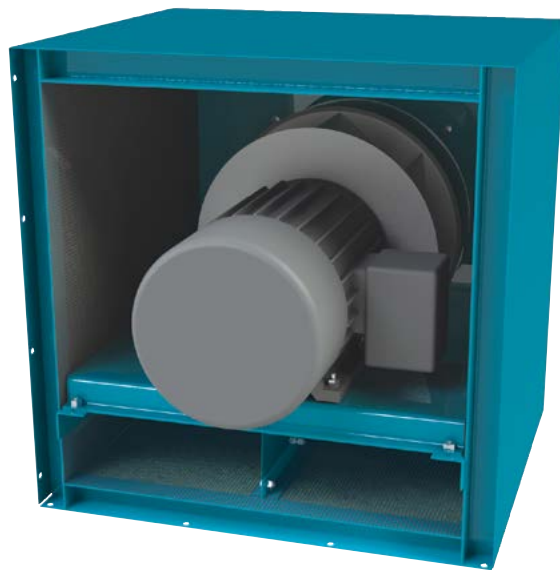

Drive End View



Twin City Fan & Blower certifies that the Model MPQN Plenum Fans shown herein are licensed to bear the AMCA Seal. The ratings shown are based on tests and procedures performed in accordance with AMCA Publication 211 and AMCA Publication 311 and comply with the requirements of the AMCA Certified Ratings Program.

Refer to Catalog 491 for sound power levels.

Models

MPQN | MPQS

The MPQN and MPQS offer many of the same advantages of the venerable EPQN plenum fan. The MPQN and MPQS can be used as a single fan or in parallel to construct a multiple fan system. By using multiple MPQN fans in parallel, sound power levels in low octave bands can be significantly reduced over alternative fan selections. In addition, considerable axial space savings is achieved over a single fan selection.

Twin City Fan & Blower, the world's largest supplier of plenum fans, offers the Modular Plenum Fan (MPQN), AMCA licensed for sound and air.

Sizes

12" to 49" wheel diameters

Performance

Airflow to 76,000 CFM

Static pressure to 12" w.g.

Classes

Class II available in sizes 122 to 490.

Class III available in sizes 182 to 490.

See dimensional drawing on page 10.

Fan Application

Plenum fans are unshoused fans designed to operate inside of field-fabricated or factory-built air handling units.

The fan wheel pressurizes the entire surrounding air plenum in which the fan is installed, allowing air ducts from any direction to be directly connected to the air handling unit enclosure. This design generally saves space by eliminating the fan housing, transitions, and diffusers within the air handling unit.

Plenum fans have found a ready acceptance in the air conditioning industry. In addition, the construction versatility, adaptability in the direction of the discharges, suitability for internal isolation and application of sound panels, and generally lower cost makes it a very popular fan arrangement.

The MPQN and MPQS fans, when used in parallel, can offer further advantages over a standard plenum fan. By using multiple fans in parallel, uniform flow can be achieved with less axial length in a given air handling unit. The use of multiple MPQN fans in parallel can also serve to reduce sound levels, possibly eliminating the need for additional sound attenuation within the unit.

Arrangement 4 (Horizontal)

Direct drive Arrangement 4 mounts the fan wheel directly onto the motor shaft. This arrangement provides a compact fan/motor unit which eliminates belt residue and requires less maintenance than other arrangements.

For these reasons, Arrangement 4 modular plenum fans are widely used in cleanroom, pharmaceutical, and other critical applications.

The MPQN and MPQS can be selected to provide desired performance at direct drive, synchronous, motor speeds. The MPQN and MPQS can also be selected to operate at peak efficiency at non-synchronous motor speeds, through the use of a variable frequency drive (VFD).

Compact & Configurable Design

Space and air-handling unit design are often key considerations in the selection of plenum fans, making the compact, configurable modular Arrangement 4 an ideal choice.

The Arrangement 4 configuration places the motor mounting within the framework of the fan itself. This allows for a simple mounting option for an individual modular fan within an air-handling unit.

This compact design also allows for easy stacking and configurable mounting and operating modular fans in parallel.

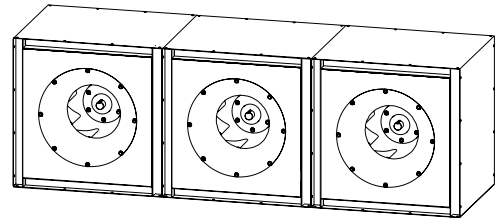
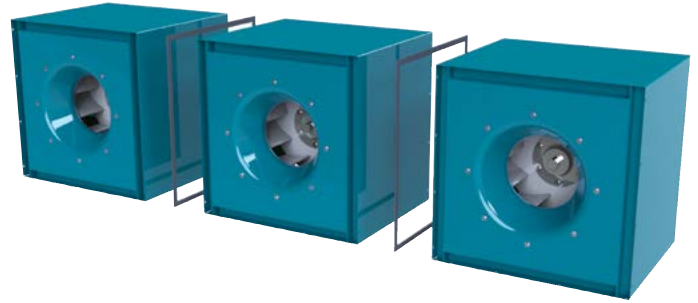

1 x 3 Horizontal Layout

FAN SIZE	MAXIMUM STACKING HEIGHT
122	3
150	3
165	3
182	3
200	3
222	3
245	3
270	2
300	2
330	2
365	2
402	1
445	1
490	1

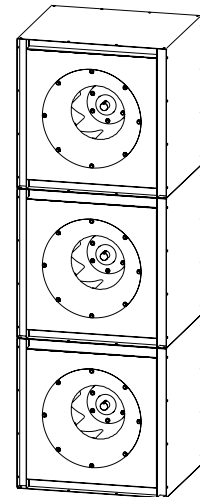

3 x 1 Vertical Layout

MPQN ADVANTAGE



Outlet Sound Power Level Comparison

Selection Point: 34,000 CFM @ 4"SP

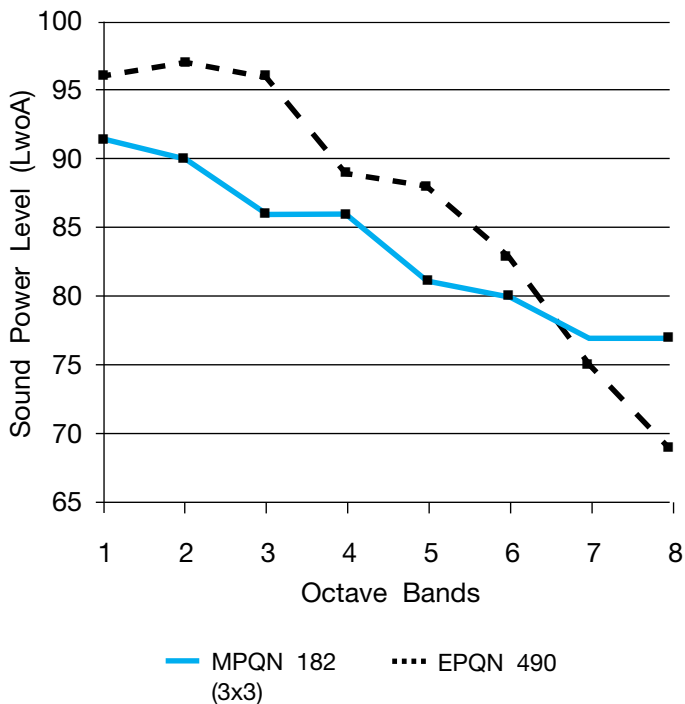

Figure 1

Sound Power	1	2	3	4	5	6	7	8	LwoA
MPQN 182 (3 x 3)	92	90	86	86	81	80	77	77	88
EPQN 490	96	97	96	89	88	83	75	69	93

The MPQN plenum fans offer unique performance features that are beneficial for many sound sensitive and higher pressure applications. The fan system is advantageous by providing uniform air distribution downstream of the fan, allowing for better air distribution through AHU components. The use of multiple fans in parallel allows a shorter AHU (in axial direction of flow), and provides redundancy for critical fan applications.

The MPQN features a 12-bladed airfoil wheel versus the 8- to 10-bladed wheels with most other competition. The "Q" in the MPQN designates for Better Noise Quality. Noise quality is a subjective description for noise that is less objectionable.

The design provides lower sound power levels at the lower octave bands which are the most difficult to attenuate. Furthermore, the 12-bladed fan impeller offers a higher blade pass frequency. This in turn transfers sound power levels to the higher octave bands (Figure 1), which allows for easier attenuation of the noise. Sound levels are often influenced by the noise occurring at the blade pass frequency (Blade Pass Frequency = RPM x Number of blades/60). In many applications, the use of the MPQN design will move the blade pass frequency from the 2nd octave band to the 3rd octave band. Acoustic silencers will normally perform about 10 dB better in the 3rd band.

With the use of the 12-bladed impeller, sound quality is improved by reducing the change of abrupt sound levels between neighboring octave bands, providing a more balanced sound level across the octave bands. Although the overall A-weighted sound power levels of a nine-bladed fan may be slightly lower, the sound "quality" of the 12-bladed MPQN fan may be desirable for the application as it is more pleasing to the human ear.

The MPQN offers the benefit of reduced low-frequency casing radiated noise due to the small lattice structure opening and end reflection. The insulated housing absorbs some noise generated by the fan, and the decreased size of the discharge opening results in a degree of attenuation due to end reflection.

Figure 1 demonstrates the sound comparison between the single plenum fan and the multi-fan system with 12-bladed wheel and insulated enclosure. The multi-fan system generates less outlet sound power levels at the lower frequencies.

Wheels

High efficiency, non-overloading airfoil wheels are provided on all sizes. Aluminum wheels using extruded aluminum blades are standard, a popular choice for applications requiring precision balance and improved reliability.

Inlet Cones

Heavy-gauge, spun steel inlet cones are closely matched to the wheel intake rim to ensure efficient and quiet operation.

Serviceability

Class II MPQN and MPQS fans feature a bolt-on motor base allowing for easy service by sliding out the motor/impeller assembly.

Structural Frame

Frames are constructed of heavy-gauge steel, continuously welded at all connections for maximum strength and rigidity. Mounting the MPQN and MPQS as a parallel

system allows for low vibration levels due to the unique individual rigid housings and vibration dampening gasket mounted between the fans.

Sound Insulation (MPQN only)

The sheet metal module encloses sound insulation for sound attenuation. Insulation is protected with both a vapor barrier for IAQ (indoor air quality) and galvanized, perforated steel maintaining sound attenuation while preventing insulation shedding on the air path side.

Isolation

Sizes 122-270 are designed to operate at adequate vibration levels where spring isolation is not essential. All sizes are designed to mount directly onto spring isolators when vibration isolation is preferred. Twin City Fan & Blower Engineering can also provide custom vibration isolation solutions for parallel fan systems.

FLOW MEASUREMENT SYSTEM

Piezometer Ring (Airflow Measuring System)

A piezometer ring is available on plenum fans, as well as other Twin City Fan housed fans, as part of an airflow measuring system, based on the principle of a flow nozzle. The inlet cone of the fan is used as the flow nozzle. The flow can be calculated by measuring the pressure drop through the inlet cone. No tubes or sensors are inserted in the high velocity airstream which could obstruct airflow.

The system consists of a piezometer ring mounted at the throat and a static pressure tap mounted on the face of the inlet cone. A differential pressure transducer and digital display can also be provided.

The pressure drop is measured from the tap located on the face of the inlet cone to the piezometer ring in the throat. The inlet tap is connected to the high-pressure side

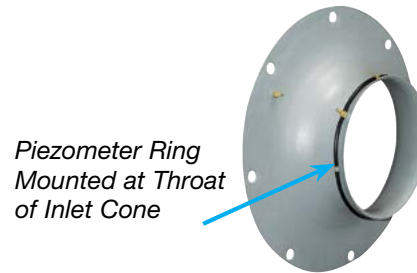

of the transducer and the piezometer ring is connected to the low-pressure side. See diagram on right.

Based on Twin City Fan laboratory tests, the system was determined to be accurate within +/-5%.

Refer to Twin City Fan Engineering Supplement ES-105.

NOTE: Twin City Fan does not recommend placement of flow measuring probes inside the fan inlet cone in the path of airflow. These devices create disturbances and unpredictable performance losses. Twin City Fan will not be responsible for loss of performance due to such devices.

Inlet Screen

Heavy-gauge barbecue grill style inlet screen that nests in the inlet funnel for personnel protection on non-ducted inlets.

Isolation Gasket

Isolation gaskets designed to separate MPQN or MPQS fans from one other when used in parallel are standard accessories on all MPQN and MPQS fans when specified.

ACCESSORIES

Shaft Grounding Ring (SGR)

Recommended for all MPQN and MPQS fans, a shaft grounding ring is mounted to the motor providing motor bearing protection. By diverting variable frequency drive (VFD) induced stray voltages to ground through the shaft grounding ring instead of the motor bearings, motor life is extended.

Maximum RPM, Wheel Weights & WR²

FAN SIZE	WHEEL DIA. (IN.)	CLASS II			CLASS III		
		MAX. RPM (70°F)	WT. (LB)	WR ² (LB-FT)	MAX. RPM (70°F)	WT. (LB)	WR ² (LB-FT)
122	12.40	3800	9	0.9	N/A	N/A	N/A
150	13.98	3800	12	1.7	N/A	N/A	N/A
165	15.75	3468	15	2.9	N/A	N/A	N/A
182	18.25	2930	18	6.1	3767	21	6.2
200	20.00	2674	21	7.4	3438	24	9.3
222	22.25	2403	30	12	3090	34	15
245	24.50	2183	35	21	2806	38	22
270	27.00	1981	40	29	2546	47	32
300	30.00	1783	54	51	2291	58	52
330	33.00	1620	67	76	2083	72	77
365	36.50	1465	79	112	1884	84	114
402	40.25	1329	93	165	1708	98	166
445	44.50	1202	135	253	1545	142	256
490	49.00	1091	164	391	1403	174	535

Bare Fan Weights

FAN SIZE	WHEEL DIA. (IN.)	CLASS II	CLASS III
122	12.40	149	N/A
150	13.98	173	N/A
165	15.75	250	N/A
182	18.25	337	373
200	20.00	423	467
222	22.25	505	555
245	24.50	681	748
270	27.00	810	944
300	30.00	997	1164
330	33.00	1200	1397
365	36.50	1506	1738
402	40.25	1936	2347
445	44.50	2363	2792
490	49.00	2939	3482

NOTE:
Weights do not include motor.

PERFORMANCE DATA

122 MPQN/MPQS

Wheel Diameter: 12.40"
Outlet Area: 2.40 ft²

Fan Efficiency Grade: FEG80
Max. BHP = 0.047 x (RPM / 1000)³

CFM	OV	1" SP		2" SP		3" SP		4" SP		5" SP		6" SP		7" SP		8" SP		9" SP		10" SP		12" SP	
		RPM	BHP	RPM	BHP	RPM	BHP	RPM	BHP	RPM	BHP	RPM	BHP	RPM	BHP	RPM	BHP	RPM	BHP	RPM	BHP	RPM	BHP
1000	417	1751	0.25	2146	0.46																		
1100	458	1838	0.28	2220	0.51																		
1200	500	1926	0.31	2297	0.57	2612	0.84																
1400	583	2113	0.39	2465	0.69	2760	0.99	3025	1.30														
1600	667	2313	0.49	2638	0.82	2921	1.15	3174	1.50	3405	1.85												
1800	750	2521	0.61	2818	0.96	3092	1.34	3333	1.72	3557	2.11	3765	2.51										
2000	833	2735	0.75	3009	1.13	3266	1.54	3503	1.96	3716	2.39												
2200	917	2954	0.91	3208	1.33	3447	1.77	3675	2.22														
2400	1000	3176	1.10	3413	1.55	3636	2.02																
2800	1167	3628	1.56																				
3200	1333																						
3600	1500																						

MAXIMUM RPM: CLASS II = 3800

150 MPQN/MPQS

Wheel Diameter: 13.98"
Outlet Area: 3.07 ft²

Fan Efficiency Grade: FEG75
Max. BHP = 0.087 x (RPM / 1000)³

CFM	OV	1" SP		2" SP		3" SP		4" SP		5" SP		6" SP		7" SP		8" SP		9" SP		10" SP		12" SP	
		RPM	BHP	RPM	BHP	RPM	BHP	RPM	BHP	RPM	BHP	RPM	BHP	RPM	BHP	RPM	BHP	RPM	BHP	RPM	BHP	RPM	BHP
1200	391	1502	0.29																				
1400	456	1621	0.35	1960	0.65																		
1600	521	1744	0.42	2068	0.76	2340	1.11																
1800	587	1875	0.51	2185	0.88	2445	1.27	2679	1.67														
2200	717	2156	0.72	2427	1.15	2674	1.62	2889	2.08	3091	2.57	3279	3.06										
2600	847	2450	0.99	2689	1.49	2914	2.02	3123	2.56	3310	3.11	3487	3.67	3656	4.25								
3000	978	2755	1.34	2969	1.90	3170	2.49	3364	3.10	3547	3.73	3715	4.36										
3400	1108	3066	1.77	3259	2.40	3442	3.05	3618	3.72	3789	4.42												
3800	1238	3382	2.30	3558	2.99	3726	3.71																
4200	1369																						
4600	1499																						
5000	1629																						

MAXIMUM RPM: CLASS II = 3800

Class II = First white section

Class III = Blue shaded section

Underlined figures indicate Maximum Static Efficiency

Performance certified is for installation Type A; Free inlet, Free outlet.

Power rating (BHP) does not include transmission losses.

Performance ratings do not include the effects of appurtenances (accessories).

Model MPQS is not licensed to bear the AMCA seal.

245 MPQN/MPQS

Wheel Diameter: 24.50"
Outlet Area: 9.38 ft²

Fan Efficiency Grade: FEG71
Max. BHP = 1.926 x (RPM / 1000)³

Table with 14 columns (CFM, OV, 1" SP, 2" SP, 3" SP, 4" SP, 5" SP, 6" SP, 7" SP, 8" SP, 9" SP, 10" SP, 12" SP) and multiple rows of performance data.

MAXIMUM RPM: CLASS II = 2183 CLASS III = 2806

270 MPQN/MPQS

Wheel Diameter: 27.00"
Outlet Area: 11.39 ft²

Fan Efficiency Grade: FEG71
Max. BHP = 3.131 x (RPM / 1000)³

Table with 14 columns (CFM, OV, 1" SP, 2" SP, 3" SP, 4" SP, 5" SP, 6" SP, 7" SP, 8" SP, 9" SP, 10" SP, 12" SP) and multiple rows of performance data.

MAXIMUM RPM: CLASS II = 1981 CLASS III = 2546

300 MPQN/MPQS

Wheel Diameter: 30.00"
Outlet Area: 14.06 ft²

Fan Efficiency Grade: FEG71
Max. BHP = 5.296 x (RPM / 1000)³

Table with 14 columns (CFM, OV, 1" SP, 2" SP, 3" SP, 4" SP, 5" SP, 6" SP, 7" SP, 8" SP, 9" SP, 10" SP, 12" SP) and multiple rows of performance data.

MAXIMUM RPM: CLASS II = 1783 CLASS III = 2291

330 MPQN/MPQS

Wheel Diameter: 33.00"
Outlet Area: 17.02 ft²

Fan Efficiency Grade: FEG71
Max. BHP = 8.539 x (RPM / 1000)³

Table with 14 columns (CFM, OV, 1" SP, 2" SP, 3" SP, 4" SP, 5" SP, 6" SP, 7" SP, 8" SP, 9" SP, 10" SP, 12" SP) and multiple rows of performance data.

MAXIMUM RPM: CLASS II = 1620 CLASS III = 2083

Class II = First white section
Class III = Blue shaded section
Underlined figures indicate Maximum Static Efficiency

Performance certified is for installation Type A; Free inlet, Free outlet.
Power rating (BHP) does not include transmission losses.
Performance ratings do not include the effects of appurtenances (accessories).
Model MPQS is not licensed to bear the AMCA seal.

Horizontal, Arr. 4 - Class II

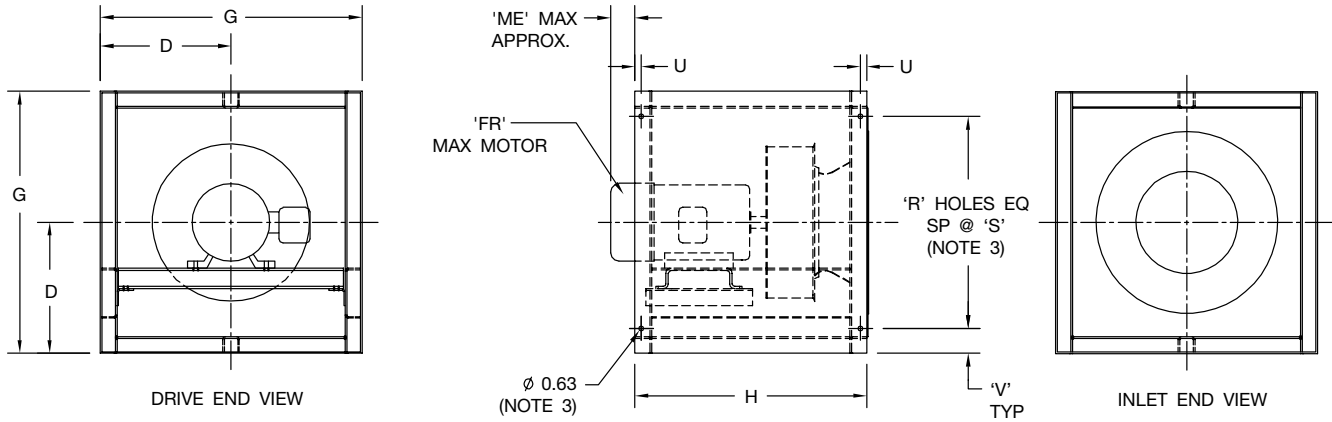

NOTES:

- Horizontal application only.
- CW rotation is standard, CCW rotation is optional. Rotation is determined by viewing the drive end.
- Mounting hole pattern typical on inlet and drive end on all four sides. 3/8" diameter mounting hardware suggested. See IOM-110 for fan installation instructions.
- Model MPQN provides acoustically insulated housing with perforated plate separating insulation from airstream. Model MPQS is identical to MPQN with the exception of the acoustical insulation and perforated plate.

SIZE	G	D	H	'R' PER SIDE	S	U	V	'ME' MAX REF	MAX 'FR'
122	23.00	11.50	20.00	2	16.81	1.13	3.13	2.25	184T
150	25.38	12.69	21.00	2	19.19	1.13	3.13	6.25	213T
165	28.06	14.06	23.63	3	10.94	1.13	3.13	4.81	215T
182	31.81	15.94	27.38	3	12.75	1.13	3.13	8.56	254T
200	34.50	17.25	30.00	3	14.13	1.13	3.13	7.19	254T
222	39.81	19.94	33.38	3	17.81	1.75	2.13	5.44	256T
245	43.25	21.63	36.75	3	19.50	1.75	2.13	6.84	284T
270	46.94	23.50	40.50	4	14.25	1.75	2.13	5.00	286T
300	51.50	25.75	45.00	4	15.75	1.75	2.13	5.50	324T
330	55.94	28.00	49.50	4	17.25	1.75	2.13	3.25	326T
365	61.25	30.63	54.75	5	14.25	2.25	2.13	5.69	405T
402	68.81	34.44	60.38	5	15.63	2.25	3.13	3.13	405T
445	75.25	37.63	66.75	5	17.25	2.25	3.13	0.13	405T
490	81.94	41.00	73.50	5	18.94	2.25	3.13	1.38	444T

BC1003160E

DIMENSIONS ARE SUBJECT TO CHANGE. CERTIFIED DRAWINGS AVAILABLE UPON REQUEST.





Models

MPQN | MPQS

Fans shall be Model MPQN or MPQS centrifugal plenum (plug) type, as manufactured by Twin City Fan & Blower, Minneapolis, Minnesota.

PERFORMANCE — Fans shall be tested in accordance with ANSI/AMCA Standard 210 (air performance) and 300 (sound performance) in an AMCA accredited laboratory. Performance ratings (MPQN only) shall conform to AMCA Standard 205 (fan efficiency grade), Publication 211 (air performance) and Publication 311 (sound performance). Fans (MPQN only) shall be licensed to bear the AMCA certified ratings seal for both sound and air, and fan efficiency grade (FEG). Sound certification shall apply to both inlet and outlet sound power levels.

Fans shall have a sharply rising pressure characteristic extending through the operating range and continuing to rise beyond the peak efficiency to ensure quiet and stable operation. Fans shall have a non-overloading design with self-limiting horsepower characteristics and shall reach a peak in the normal selection area. All fans shall be capable of operating over the minimum pressure class limits as specified in AMCA Standard 99.

CONSTRUCTION — Fans shall be designed without a scroll type housing and shall incorporate a non-overloading type backward inclined airfoil blade wheel, heavy-gauge reinforced steel inlet plate and structural steel frame.

INSULATION (MPQN Only) — Fans shall be provided with a minimum of 2" acoustical insulation. Insulation shall be protected on the airstream side with a non-friable vapor barrier preventing insulation shedding for IAQ (indoor air quality). Galvanized, perforated steel shall be located on the airstream side of the vapor barrier providing additional protection without sacrificing air and sound performance.

FRAME AND INLET PANEL — Inlet panels shall be of heavy-gauge reinforced steel construction. The inlet panel incorporates a removable spun inlet cone designed for smooth airflow into the accompanying inlet retaining ring of the fan wheel. A square, formed lip suitable for attachment of a boot connector shall surround the unit.

WHEEL — Wheels shall have a spun non-tapered style blade retaining ring on the inlet side to allow higher efficiencies over the performance range of the fan. Wheels shall have airfoil-shaped extruded aluminum blades. All hollow blade wheels shall be continuously welded around all edges. Wheels shall have twelve blades for better sound quality. All wheels shall be statically and dynamically balanced on precision electronic balancers to a Balance Quality Grade G6.3 per ANSI/AMCA 204 or better.

FINISH AND COATING — The entire fan assembly shall be thoroughly degreased and deburred before application of a rust-preventative coating. Aluminum components shall be unpainted.

FACTORY RUN TEST — All fans prior to shipment shall be completely assembled and test run as a unit at the specified operating speed or maximum RPM allowed for the particular construction type. Maximum vibration shall be within the limits of ANSI/AMCA 204 Fan Application Category BV-4. Balance readings shall be taken by electronic type equipment in the axial, vertical, and horizontal directions on each of the bearings. Records shall be maintained and a written copy shall be available upon request.

GUARANTEE — The manufacturer shall guarantee the workmanship and materials for its MPQN fans for at least one (1) year from startup or eighteen (18) months from shipment, whichever occurs first.

INDUSTRIAL PROCESS AND COMMERCIAL VENTILATION SYSTEMS

CENTRIFUGAL FANS | UTILITY SETS | PLENUM & PLUG FANS | INLINE CENTRIFUGAL FANS
MIXED FLOW FANS | TUBEAXIAL & VANEAXIAL FANS | PROPELLER WALL FANS | PROPELLER ROOF VENTILATORS
CENTRIFUGAL ROOF & WALL EXHAUSTERS | CEILING VENTILATORS | GRAVITY VENTILATORS | DUCT BLOWERS
RADIAL BLADED FANS | RADIAL TIP FANS | HIGH EFFICIENCY INDUSTRIAL FANS | PRESSURE BLOWERS
LABORATORY EXHAUST FANS | FILTERED SUPPLY FANS | MANCOOLERS | FIBERGLASS FANS | CUSTOM FANS



TWIN CITY FAN & BLOWER
WWW.TCF.COM

5959 TRENTON LANE N | MINNEAPOLIS, MN 55442 | PHONE: 763-551-7600 | FAX: 763-551-7601

©2018 Twin City Fan Companies, Ltd., Minneapolis, MN. All rights reserved. Catalog illustrations cover the general appearance of Twin City Fan & Blower products at the time of publication and we reserve the right to make changes in design and construction at any time without notice.