



INDUSTRIAL PROCESS AND
COMMERCIAL VENTILATION SYSTEMS

FIBERGLASS PRESSURE BLOWER

Model HPF





Overview

HPF

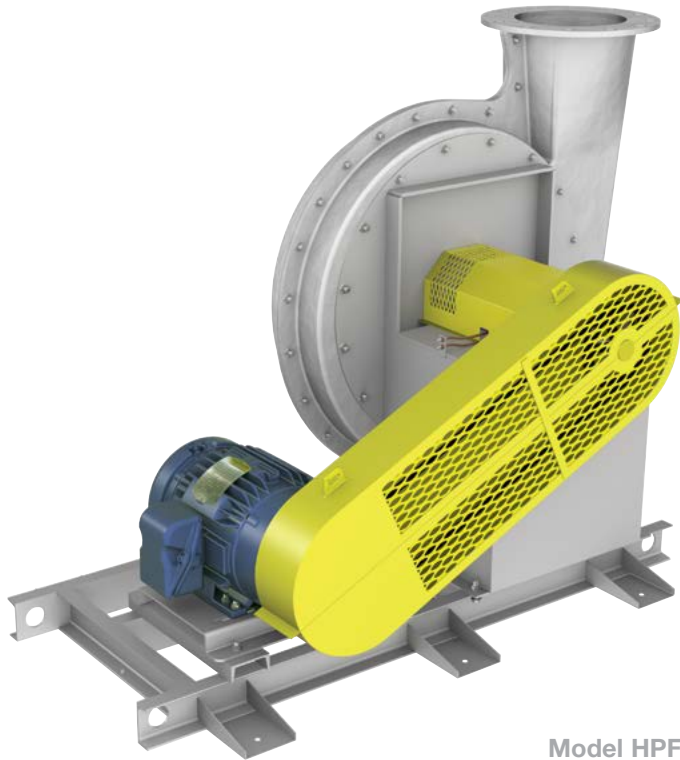

Model HPF,
Arrg. 1

Twin City Fan & Blower Series 14 Fiberglass Pressure Blowers are recommended for relatively small, but constant, volumes of air at high static pressure.

All airstream parts are constructed of fiberglass reinforced plastic, with excellent corrosion resistance to most chemicals. The radial type wheel is resin transfer molded (RTM) from a fire-retardant resin-glass mixture providing optimal strength and corrosion resistance. All wheels are dynamically and statically balanced after testing.

Belt driven Arrangement 1 or direct drive Arrangement 8, 9 and 10 are available and are supplied with heavy-gauge steel bases, finished with two coats of light grey epoxy paint. Arrangement 1 can be furnished with a slide rail base for ease in adjusting belt tension.

Twin City Fan & Blower recommends an Arrangement 1 furnished with an optional steel unitary base constructed of structural channel and finished with two coats of light grey epoxy paint. This configuration allows assembly of the fan, motor and drive as an integral unit.

Wheel Design

Cast from a resin-glass mixture providing optimal strength and corrosion resistance.

Sizes and Performance

18" to 28" wheel diameters
Airflow to 4,700 CFM
Static pressure to 36" w.g.

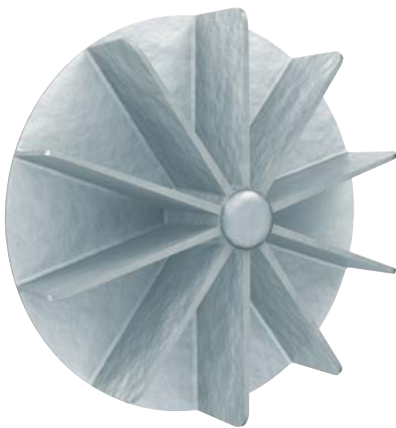

HPF Wheel



For complete product performance, drawings and available accessories, download our Fan Selector program at tcf.com.

Accessories

HPF

Belt Guard The belt guard is made of mild steel and is available for Arrangement 1 and 9 sizes.

Coupling Guard The coupling guard is made of mild steel and is available for all Arrangement 8 sizes.

Inlet/Outlet Flange Fiberglass flanges are standard on the inlet and outlet. Drilling of holes in the flange is available as an option.

Shaft and Bearing Guard The mild steel shaft and bearing guard is available on Arrangements 1, 8, 9 and 10.

Shaft Seal The Viton shaft seal rides against a heavy Teflon wear plate. It is suitable for operation up to 225°F.

Housing Drain The housing drain is provided with 1" PVC threaded pipe coupling located at the low point of the scroll. A plug is also available.

Graphite Impregnation Static grounding by graphite impregnation is available as an option.

316 Stainless Steel Fan Shaft A 316SS shaft is available as an option.

Special Fiberglass Materials Vinyl ester, resin, synthetic veil, abrasion-resistant construction and static-grounding are available as options.



STANDARD CONFIGURATIONS

CLOCKWISE (CW) - ROTATION & DISCHARGE (ROTATION VIEW FROM DRIVE SIDE)

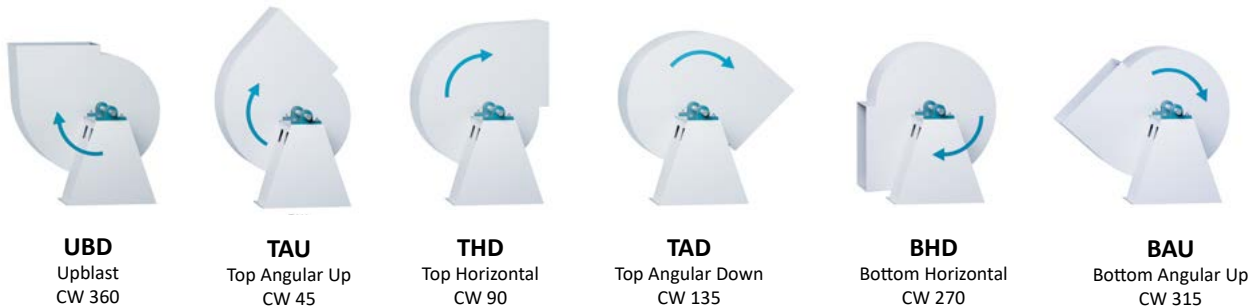

COUNTER CLOCKWISE (CCW) - ROTATION & DISCHARGE (ROTATION VIEW FROM DRIVE SIDE)

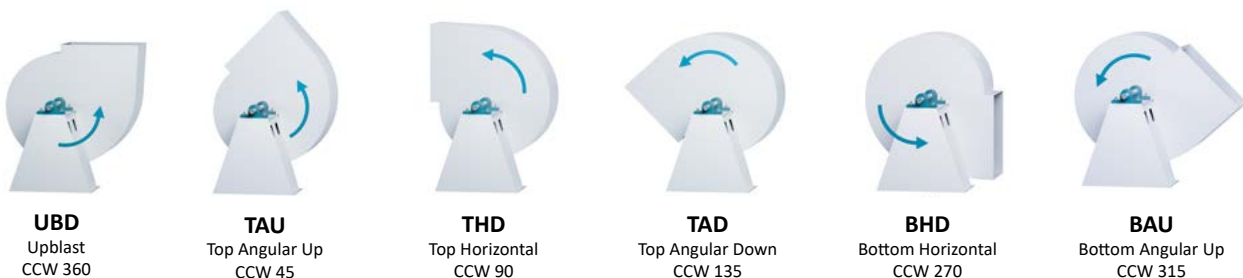

PERFORMANCE CORRECTION FOR TEMPERATURE & ALTITUDE

The performance tables in this catalog are based on standard air density: 70°F at sea level (0.075 lbs./cu.ft. density). The fan performance tables provide the fan RPM and brake horsepower requirements for the given CFM and static pressure, at standard air density.

When the fan performance is not at standard conditions, the performance must be converted to standard conditions before entering the fan performance tables. The fan performance is converted to standard conditions by using the "Temperature and Altitude Density Ratio" from Table 1 shown below.

The following is an example explaining how to convert the fan's performance to standard conditions.

Example: A Size 22/10 HPF is to provide 2,200 CFM at 12" SP, at 200°F at 2,000 ft. elevation (0.056 lbs./cu. ft. density).

- For 200°F and 2,000 ft. elevation, Table 1 shows a density ratio of 0.747.
- The operating static pressure is 12" SP.
- Using the temperature and altitude density ratio, the static pressure at standard conditions is determined as follows:

$$\frac{\text{Operating Static Pressure}}{\text{Temp. \& Alt. Density Ratio}} = \text{Static Pressure at Standard Conditions}$$

For this example:

12" SP ÷ 0.747 = 16" SP at Standard Conditions

Turn to page 5 for the Size 22/10 HPF fan performance table. Using 2,200 CFM at 16" SP at standard conditions, find the RPM and brake horsepower. The answer is 2,471 RPM and 9.03 BHP. Note: 9.03 BHP is the brake horsepower required at standard conditions and is also referred to as the "cold brake horsepower" or "starting brake horsepower."

The actual brake horsepower at the operating condition of 200°F and 2,000 ft. elevation is determined by the following equation:

$$\frac{\text{Brake HP at Standard Conditions}}{\text{Temp. \& Alt. Density Ratio}} = \text{Brake HP at Operating Conditions}$$

For this example:

9.03 x 0.747 = 6.75 BHP at Operating Conditions

Therefore, the Size 22/10 HPF fan providing 2,200 CFM at 12" SP, at 200°F will run at 2,471 RPM and will require 6.75 BHP at operating conditions and 9.03 BHP at starting.

Maximum Safe Speeds

When operating at temperatures other than 70°F, the maximum speed of the fan is affected. To determine the maximum speed, at the operating temperature, a "Maximum Safe Speed Factor" (Table 3) is applied to the maximum speed of the fan (Table 2).

Example: The maximum safe speed for a Size 22/10 HPF operating at 200°F is 3,600 RPM. The calculation is shown below.

$$\frac{\text{Max. RPM at 70°F}}{\text{Temp. Factor (Table 3)}} = \text{Max. RPM at Operating Temp.}$$

For this example:

3,600 x 0.85 = 3,060 Max. RPM at 200°F

Table 2.

Max. Safe Speeds (at 70°F)

SIZE	MAX. RPM
18/8	4000
22/10	3600
28/12	2500

Table 3.

Max. Safe Speed Factors

TEMP.	FACTOR
150°F	1.00
200°F	0.85
225°F	0.60

Table 4. Metric Conversion Factors

	ENGLISH	FACTOR	METRIC
VOL. FLOW	CFM	0.000472	m ³ /s
PRESSURE	SP	0.24836	kPa
POWER	BHP	0.7457	bkW
VELOCITY	FPM	0.00508	m/s
DENSITY	lbs/ft ³	16.018	kg/m ³
SPEED	RPM	0.01667	rps
AREA	ft ²	0.0929	m ²
CIRCUMFERENCE	ft.	0.3048	m
DIAMETER	in.	25.4	mm

Table 1. Temperature and Altitude Density Ratios

AIR TEMP °F	ALTITUDE IN FEET ABOVE SEA LEVEL											
	0	1000	2000	3000	4000	5000	6000	7000	8000	9000	10000	15000
	BAROMETRIC PRESSURE IN INCHES OF MERCURY											
	29.92	28.86	27.82	26.82	25.84	24.90	23.98	23.09	22.22	21.39	20.58	16.89
-50	1.293	1.247	1.201	1.159	1.116	1.076	1.036	0.997	0.960	0.924	0.889	0.729
0	1.152	1.111	1.071	1.032	0.995	0.959	0.923	0.889	0.856	0.824	0.792	0.650
50	1.039	1.003	0.967	0.932	0.897	0.864	0.833	0.801	0.772	0.743	0.715	0.586
70	1.000	0.964	0.930	0.896	0.864	0.832	0.801	0.772	0.743	0.714	0.688	0.564
100	0.946	0.912	0.880	0.848	0.818	0.787	0.758	0.730	0.703	0.676	0.651	0.534
150	0.869	0.838	0.808	0.770	0.751	0.723	0.696	0.671	0.646	0.620	0.598	0.490
200	0.803	0.774	0.747	0.720	0.694	0.668	0.643	0.620	0.596	0.573	0.552	0.453
250	0.747	0.720	0.694	0.669	0.645	0.622	0.598	0.576	0.555	0.533	0.514	0.421

HPF Size 28/12 Fiberglass High Pressure Blower

Wheel Dia.: 28" Tip Speed, FPM = 7.33 x Fan RPM Outlet Dia.: 12" Max. RPM 2500

CFM	OV	4" SP		6" SP		8" SP		10" SP		12" SP		14" SP		16" SP	
		RPM	BHP	RPM	BHP	RPM	BHP	RPM	BHP	RPM	BHP	RPM	BHP	RPM	BHP
395	500														
790	1000	882	0.76												
1185	1500	895	1.10	1081	1.66	1247	2.27	1397	2.91						
1580	2000	935	1.56	1107	2.23	1260	2.94	1398	3.68	1527	4.46	1649	5.27	1765	6.12
1975	2500	994	2.16	1151	2.94	1293	3.76	1424	4.63	1545	5.51	1659	6.42	1767	7.36
2370	3000	1064	2.91	1210	3.85	1341	4.78	1463	5.74	1579	6.75	1688	7.79	1791	8.84
2765	3500	1141	3.84	1278	4.93	1402	6.02	1517	7.12	1624	8.21	1727	9.35	1826	10.52
3160	4000	1224	4.99	1353	6.22	1469	7.45	1578	8.70	1681	9.95	1778	11.20	1871	12.47
3555	4500	1312	6.38	1433	7.76	1544	9.14	1647	10.53	1744	11.92	1838	13.34	1927	14.74
3950	5000	1403	8.04	1517	9.56	1622	11.08	1721	12.63	1814	14.17	1903	15.73	1989	17.30
4345	5500	1495	9.97	1605	11.67	1705	13.34	1799	15.02	1889	16.73	1974	18.42	2056	20.13
4740	6000	1589	12.21	1695	14.09	1791	15.93	1881	17.76	1967	19.60	2049	21.44	2128	23.30

CFM	OV	18" SP		20" SP		22" SP		24" SP		26" SP		28" SP		30" SP	
		RPM	BHP	RPM	BHP	RPM	BHP	RPM	BHP	RPM	BHP	RPM	BHP	RPM	BHP
395	500														
790	1000														
1185	1500														
1580	2000	1875	6.99	1979	7.89										
1975	2500	1871	8.35	1970	9.33	2067	10.36	2161	11.42	2251	12.49	2338	13.58	2423	14.71
2370	3000	1889	9.91	1984	11.02	2075	12.14	2163	13.29	2248	14.46	2331	15.64	2413	16.87
2765	3500	1921	11.73	2011	12.93	2099	14.17	2184	15.44	2266	16.71	2345	17.99	2423	19.32
3160	4000	1961	13.76	2049	15.11	2133	16.46	2215	17.84	2294	19.22	2371	20.63	2446	22.06
3555	4500	2012	16.14	2094	17.55	2175	19.02	2254	20.51	2331	22.03	2405	23.54	2478	25.09
3950	5000	2072	18.87	2151	20.42	2227	21.96	2302	23.55	2375	25.15	2447	26.79		
4345	5500	2135	21.84	2212	23.56	2287	25.29	2359	27.00	2429	28.72	2497	30.43		
4740	6000	2204	25.16	2278	27.03	2350	28.91	2420	30.78	2489	32.68				

Underlined figures indicate maximum static efficiency.
 Performance shown is for installation type B: Free inlet, Ducted outlet.
 Power rating (BHP) does not include drive losses.
 Performance ratings do not include the effects of appurtenances in the airstream.



Arrangement 1 & 8

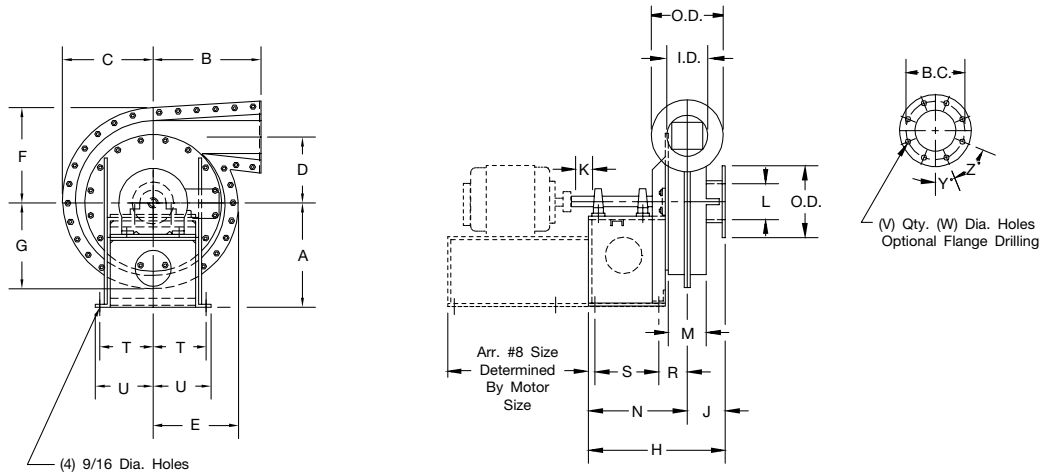

NOTE: Phantom drawing illustrates an Arrangement 8 Model HPF pressure blower.

SIZE	SHAFT DIA.	A	B	C	D	a	b	c	d	E	F	G	H	J
18" - 8"	1.50	18.38	17.00	14.00	10.50	13.63	20.13	14.38	12.88	12.50	14.75	13.25	24.25	6.63
22" - 10"	1.50	24.75	22.00	18.19	14.88	17.63	31.13	18.63	16.63	19.19	19.19	17.19	24.44	6.75
28" - 12"	1.94	30.00	28.00	22.75	18.88	22.00	39.63	23.25	20.75	24.00	24.00	21.50	26.63	8.00

SIZE	K	L	M	N	R	S	T	U	V	W	Y	Z	B.C.	O.D.	I.D.
18" - 8"	3.50	6.88	7.00	17.63	4.63	12.00	8.75	9.63	8.00	0.88	22.50	45.00	11.75	13.50	8.00
22" - 10"	4.00	9.00	7.13	17.69	4.69	12.00	11.00	11.88	12.00	1.00	15.00	30.00	14.25	16.00	10.00
28" - 12"	5.00	12.00	9.00	18.63	5.66	12.00	12.38	13.25	12.00	1.00	15.00	30.00	17.00	19.00	12.00

See page 3 for discharge positions.

AC1005856
AC1005857

Arrangement 9

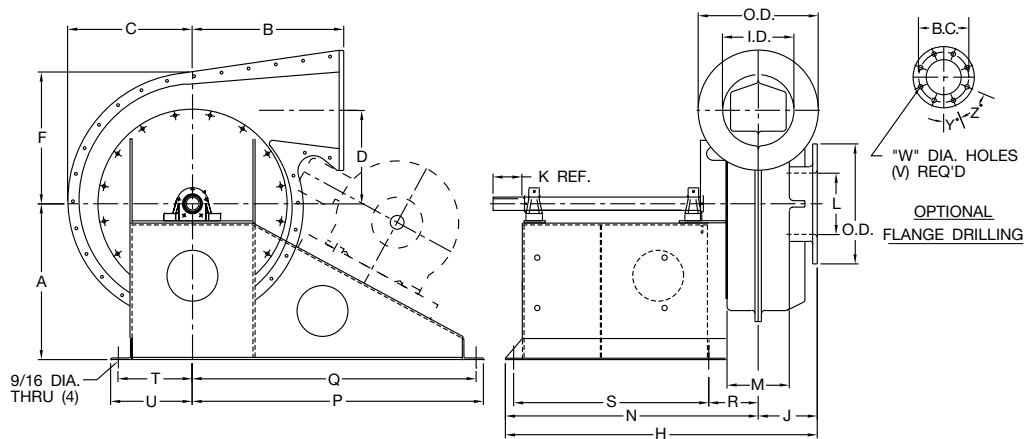

SIZE	SHAFT DIA.	A	B	C	D	a	b	c	d	e	F	G	H	J
18" - 8"	1.50	18.38	17.00	14.00	10.50	13.63	20.13	14.38	12.88	12.50	14.75	13.25	34.25	6.63
22" - 10"	1.50	24.38	22.00	18.19	14.88	17.63	31.13	18.63	16.63	16.19	19.19	17.19	39.06	6.75
28" - 12"	1.94	30.00	28.00	22.75	18.88	22.00	39.63	23.25	20.75	20.25	24.00	21.50	43.69	8.00

SIZE	K	L	M	N	P	Q	R	S	T	U	V	W	Y	Z	O.D.	I.D.	B.C.
18" - 8"	4.00	6.88	7.00	27.63	34.31	33.44	5.63	17.00	8.75	9.63	8.00	0.88	22.50	45.00	13.50	8.00	11.75
22" - 10"	4.00	9.00	7.13	32.31	36.88	35.63	5.81	20.50	10.19	11.88	12.00	1.00	15.00	30.00	16.00	10.00	14.25
28" - 12"	5.00	12.00	9.00	35.69	39.50	38.25	6.69	28.00	11.75	13.00	12.00	1.00	15.00	30.00	19.00	12.00	17.00

See page 3 for discharge positions. Please note that clockwise 45° downblast and counter-clockwise bottom horizontal discharges are not available on Arrangement 9 units.

Arrangement 10

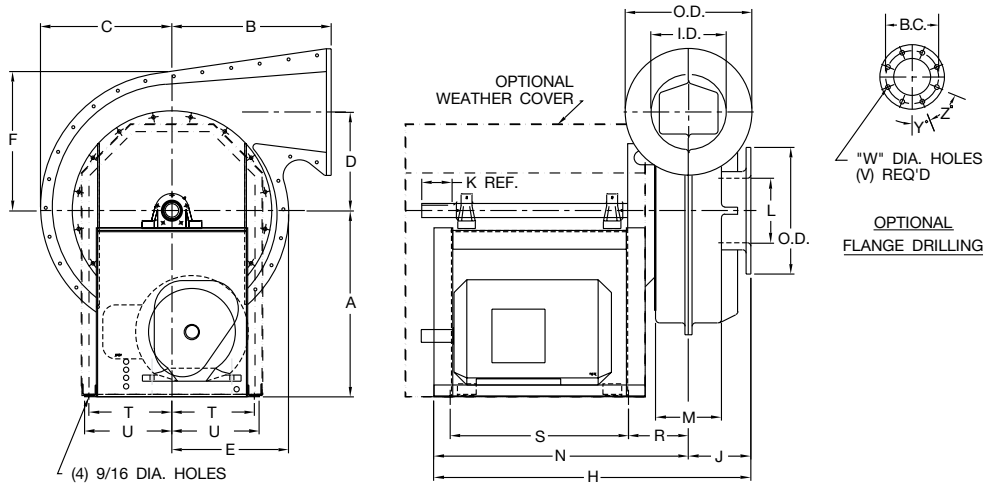

SIZE	SHAFT DIA.	A	B	C	D	a	b	c	d	E	F	G	H	J
18" - 8"	1.50	19.88	17.00	14.00	10.50	13.63	20.13	14.38	12.88	12.50	14.75	13.25	33.75	6.63
22" - 10"	1.50	23.31	22.00	18.19	14.88	17.63	31.13	18.63	16.63	16.19	19.19	17.19	38.75	6.75
28" - 12"	1.94	31.13	28.00	22.75	18.88	22.00	39.63	23.25	20.75	20.25	24.00	21.50	43.63	8.00

SIZE	K	L	M	N	R	S	T	U	V	W	Y	Z	O.D.	I.D.	B.C.
18" - 8"	4.00	6.88	7.00	27.13	6.38	19.00	8.81	9.31	8.00	0.50	22.50	45.00	13.50	8.00	11.75
22" - 10"	4.00	9.00	7.13	32.00	6.75	23.25	10.88	11.50	12.00	1.00	15.00	30.00	16.00	10.00	14.25
28" - 12"	5.00	12.00	9.00	35.63	8.63	24.50	12.13	13.00	12.00	1.00	15.00	30.00	19.00	12.00	17.00

See page 3 for discharge positions.





Model HPF

Fans shall be of the Fiberglass Reinforced Plastic Pressure Blower type, as manufactured by Twin City Fan & Blower, Minneapolis, Minnesota, and shall be of the size and capacity as indicated in the fan schedule. Centrifugal fans shall be tested in accordance with ANSI/ASHRAE 51-1985 and ANSI/AMCA 210-85 test codes and guaranteed by the manufacturer to deliver at the rated published performance levels. In addition, each unit shall be factory run tested prior to shipment.

CONSTRUCTION — All airstream components shall be fabricated of corrosion resistant fiberglass reinforced polyester resin. The radial type wheel shall be resin transfer molded from a fire-retardant resin-glass mixture, providing optimal strength and corrosion resistance and an extremely smooth surface to maximize aerodynamic performance. The fan housing shall be molded of fiberglass reinforced fire-retardant polyester.

ARRANGEMENT — The pressure blower shall be fabricated for either belt driven Arrangement 1, 9 and 10 or direct drive Arrangement 8 configuration as indicated in the fan schedule. Where indicated on the drawings or schedules, the Arrangement 1 pressure blower may be furnished with a unitary base to allow mounting of the fan and motor on a common frame.

WHEEL — The radial type wheel is resin transfer molded (RTM) from a resin-glass mixture providing optimal strength and corrosion resistance. All wheels are dynamically and statically balanced after testing.

BEARINGS — Bearings shall be oversized to ensure maximum bearing life. The belts and sheaves furnished by the manufacturer shall be selected to provide additional allowances of 1.3 to 2 times the normal satisfactory capacity.

BALANCING — The propeller assembly shall be statically and dynamically balanced in accordance with ANSI/AMCA 204-96 “Balance Quality and Vibration Levels for Fans” to Fan Application Category BV-3, Balance Quality Grade G6.3. In addition, belt driven fan propellers shall be balanced on the fan shaft after final assembly in the fan casing, in the manufacturing facility, to the following peak velocity values, filter-in, at the fan test speed:

Fan Application Category	Rigidly Mounted - (in./s)	Flexibly Mounted - (in./s)
BV-3	0.15	0.20

MOTORS — Fan motors shall be foot mounted NEMA Design B, standard industrial continuous duty, ball bearing (ODP, TEFC, EXPL), variable torque type suitable for operation on voltage, phase, and hertz, as listed in the fan schedule. Motor bearings shall have a minimum L-10 life, as defined by AFBMA, of at least 40,000 hours (200,000 hours average life).

FINISH — All steel parts are finished with an air dry epoxy paint. All fiberglass parts are coated inside and outside with resin (with UV inhibitor), approximately 10 mils in thickness, to seal the surface and provide a smooth, shiny finish. Optional resins and finishes include:

- Vinyl Ester
- Synthetic Surface Veil
- Fire-Retardant Resin
- Aluminum Oxide

ACCESSORIES — The units shall be furnished complete with:

- Flange Drilling
- Drain
- Belt Guard, OSHA
- Graphite Impregnation with Static Grounding
- Coupling Guard (Arrangement 8 Only)
- Viton Shaft Seal
- 316SS Shaft
- Abrasion-Resistant Airstream
- Unitary Base
- Vibration Isolation (RIS/Spring)
- Shaft & Bearing Guard

INDUSTRIAL PROCESS AND COMMERCIAL VENTILATION SYSTEMS

CENTRIFUGAL FANS | UTILITY SETS | PLENUM & PLUG FANS | INLINE CENTRIFUGAL FANS
MIXED FLOW FANS | TUBEAXIAL & VANEAXIAL FANS | PROPELLER WALL FANS | PROPELLER ROOF VENTILATORS
CENTRIFUGAL ROOF & WALL EXHAUSTERS | CEILING VENTILATORS | GRAVITY VENTILATORS | DUCT BLOWERS
RADIAL BLADED FANS | RADIAL TIP FANS | HIGH EFFICIENCY INDUSTRIAL FANS | PRESSURE BLOWERS
LABORATORY EXHAUST FANS | FILTERED SUPPLY FANS | MANCOOLERS | FIBERGLASS FANS | CUSTOM FANS



TWIN CITY FAN & BLOWER
WWW.TCF.COM

5959 TRENTON LANE N | MINNEAPOLIS, MN 55442 | PHONE: 763-551-7600 | FAX: 763-551-7601

©2018 Twin City Fan Companies, Ltd., Minneapolis, MN. All rights reserved. Catalog illustrations cover the general appearance of Twin City Fan & Blower products at the time of publication and we reserve the right to make changes in design and construction at any time without notice.