

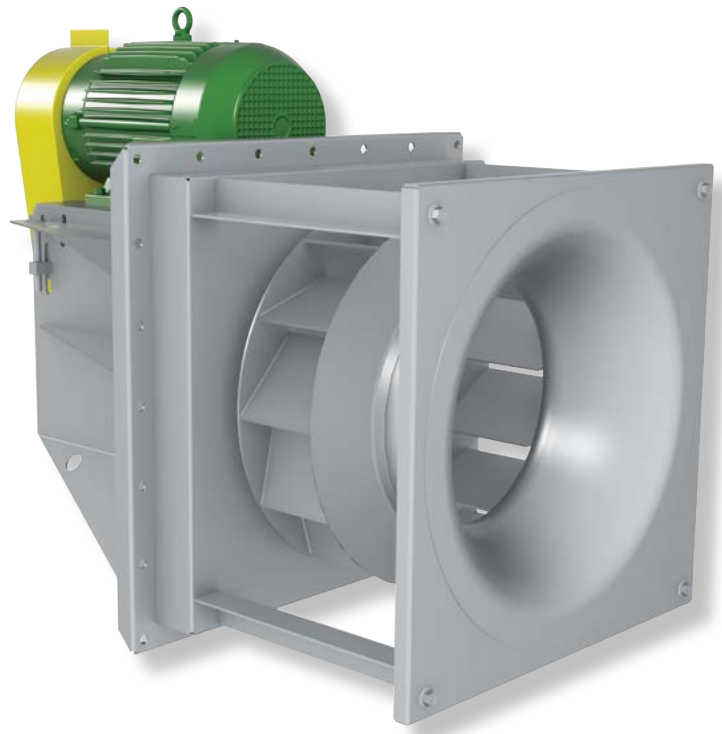

INDUSTRIAL PROCESS AND
COMMERCIAL VENTILATION SYSTEMS

PLUG FANS

MODEL BCPL





Overview

BCPL

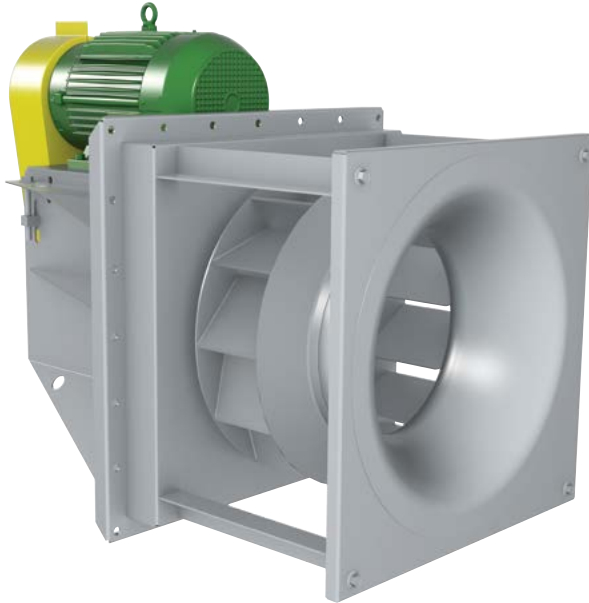

Model BCPL,
Arrangement 9

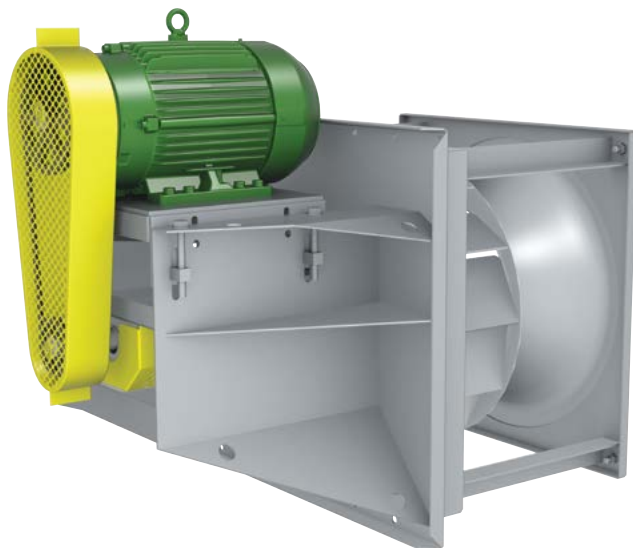

Plug fans offer great versatility for complex system configurations. Equipped with a gusseted mounting panel, they are mounted directly to the plenum wall separating the motor and drive components from the process air. Plug fans provide high efficiency recirculation air with the benefit of easy installation and removal.

Typical Applications Include

Air Curtains, Dyers, Freezers, High Temperature, Kilns, Ovens, Process Applications, Product Cooling, Re-Circulation, Air Heaters, Ceiling, Wall and Floor Panel Plenums, Degreasers, Dryers, Dust Collectors, Evaporators, Packaged Air Handlers, Parts Washers, Penthouses, Smoke Houses, Space Heaters, Spray Booths and other High Temperature Applications

Wheel Types

Flat-Bladed Backward Inclined

Arrangements

Available in Arrangement 1P, 9 and 9P (Belt Driven) and Arrangement 4 and 8P (Direct Drive) configurations

Optional Construction

High-Temperature Construction to 1000° F, Insulated Plug, Pedestal Design for Floor Mounting, Spark Resistant Construction, Special Materials, All Welded Housing, Variable Inlet Vanes, Integral Inlet Cone Assembly, Shallow Depth Inlet Cone, Special Wheel Width and Diameter

Certifications

ATEX Construction



For complete product performance, drawings and available accessories, download our Fan Selector program at tcf.com.

Overview

BCPL

BCPL plug fans from Twin City Fan & Blower are compact and versatile. Their versatility allows them to be used for air circulation in a variety of commercial and industrial applications including air curtains, air heaters, ceiling, wall and floor panel plenums, degreasers, dryers, dust collectors, evaporators, freezers, kilns, ovens, packaged air handlers, parts washers, penthouses, smoke houses, space heaters, spray booths and other high temperature applications.

Plug fans are housed in the customer's enclosure in applications where the system plenum acts as the fan housing. This configuration saves space since connecting ductwork and motor support pedestals are generally not needed. More space savings can be obtained by utilizing the wheel compartment as a pressurized chamber in lieu of a fan scroll. The use of multiple discharges from the pressurized chamber allows for additional savings by reducing ducting requirements.

BCPL plug fans feature SWSI flat-blade backward inclined, non-overloading wheels.

The unit's welded construction can withstand most industrial applications. The plug fan's motor and drive are protected from high temperatures by the customer's chamber wall or the optional insulated plug. The motor and drive are mounted to the plug panel which may be bolted or welded in place. The plug assembly may be mounted with the shaft in either the vertical or horizontal position for maximum flexibility. An all welded housing is available as an option. Standard fan is suitable for both horizontal and vertical mounting.

Sizes and Performance

12.25" to 49" wheel diameters (315 mm to 1,245 mm)

Airflow to 57,900 CFM (98,400 m³/hour)

Static pressure to 8" w.g. (2,000 Pa)



Paint Booth Ventilation

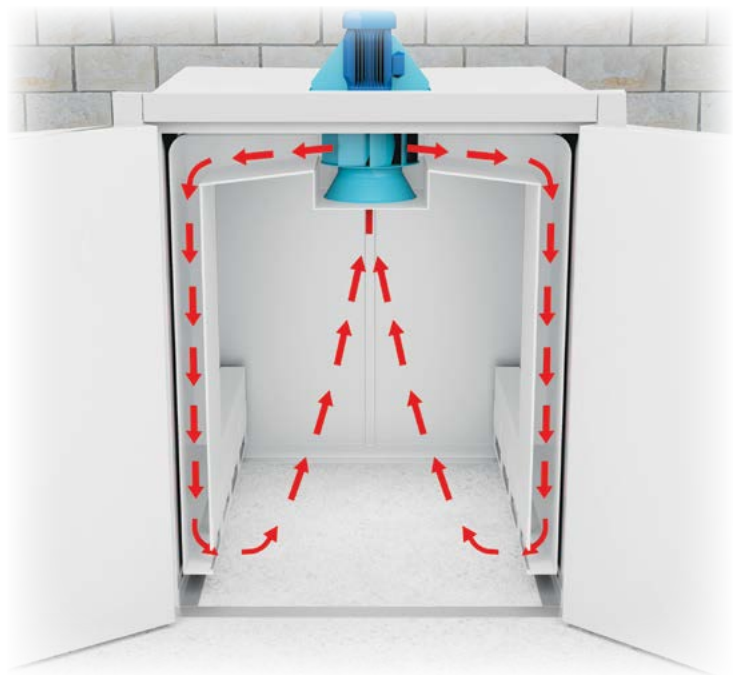

Oven Airflow

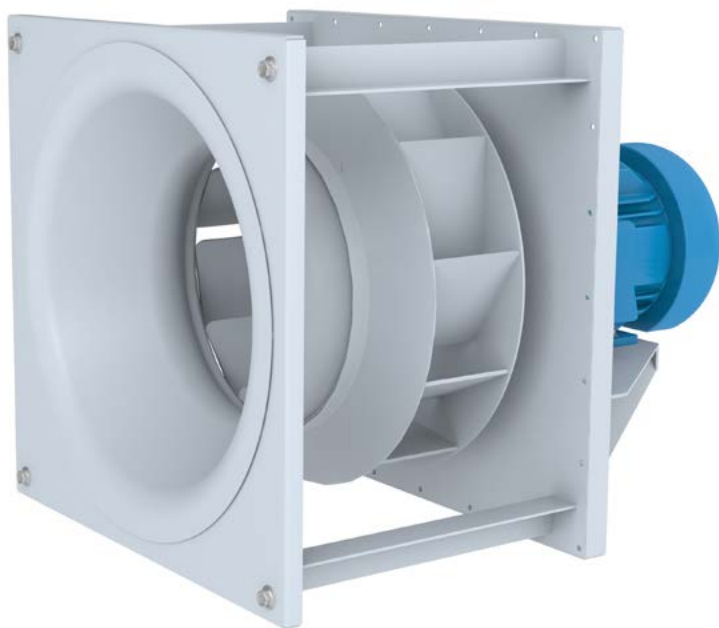

Model BCPL, Arrangement 4
with Integrated Inlet Funnel

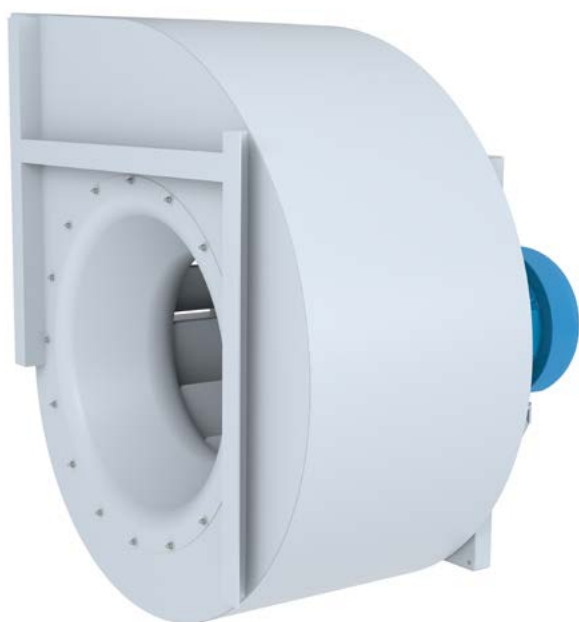

Model BCPL, Arrangement 4
with Housing

Plug Panel

Constructed of minimum 7-gauge steel with formed flanges to maintain flatness and rigidity. Panel is prepunched for bolt mounting. Panel assembly may also be welded in place. The “cross frame” bearing support is designed for maximum stability and load spreading. Bearings are serviceable without disassembly of panel or frame.

Plug Assembly

Available for both horizontal and vertical applications. Horizontal and vertical up construction is standard. Vertical down construction must be specified.

Adjustable Motor Base

The motor base is standard four point leveling and positive tension adjustment to ensure proper drive belt alignment. The motor base is heavy-gauge steel and prepunched to accept the standard motor frame specified.

Wheels

Wheels are constructed of heavy-gauge steel using flat single thickness blades, welded to both back plate and rim. Wheels are statically and dynamically balanced. Clockwise (standard) or counterclockwise rotation is available. Specify rotation as viewed from drive side.

Inlet Cones

Heavy-gauge and spun to match the wheel intake rim to ensure smooth airflow. Inlet cone flange is prepunched for mounting. Inlet cones are shipped loose as standard. An integral inlet cone with mounting panel is optional.

Shafts

Standard shaft diameters are sized for plug thicknesses to 6 inches and 1000°F operation.

Bearings

Either ball or spherical roller, heavy-duty, self-aligning, pillow block type bearings are provided. Bearing selection is based on L-10 minimum life of 40,000 hours or average life of 200,000 hours. Split roller bearings are not recommended.

High Temperature Construction

301-500°F: Includes high temperature grease, expansion and non-expansion bearings, ceramic shaft seal and shaft cooler.

501-800°F: Includes the modifications above with the addition of high temperature aluminum paint. Minimum 4" insulation is required and is available as an optional item from TCF. Be sure to apply derating factors for high temperature construction. See Table 7 on page 11.

801-1000°F: Includes the modifications above with the addition of 316 stainless steel wheel and shaft. Also includes shaft extension for the required 6" insulation. 6" insulated plug is available as an optional item. Be sure to apply stainless steel derating factors for temperature. See Table 7 on page 11.

Insulated Plug

Protects motor and drive components from heat. An insulated plug is recommended for temperatures above 300°F. Available in 4" and 6" thicknesses. Special thicknesses to match customer's insulated wall are available. Plug is assembled to mounting panel when ordered. See Table 1 on page 10 for maximum RPMs.

All Welded Housing

Heavy-gauge steel housing is provided with wheel opening on each side and weld studs on the inlet side for cone mounting. Specify rotation and discharge as viewed from drive side to ensure proper stud placement. Housing supports and attachments for wall mounting to be provided by others. See page 19 for dimensions.

Variable Inlet Vanes

Vane blades are cantilever design or center supported, equipped with permanently lubricated bearings and ball joints for smooth and easy operation. Vane assemblies are external type for sizes 122 through 150 and nested for sizes 165 through 490. Standard inlet vanes are applicable to 300°F. Consult factory for dimensions and higher temperatures.

Spark Resistant Construction

Fan applications may involve the handling of potentially explosive or flammable particles, fumes or vapors. Such applications require careful consideration by the system designer to ensure the safe handling of such gases. Twin City Fan & Blower offers the following classifications of spark resistant construction per AMCA Standard 99-0401-86. It is the specifier or the user's responsibility to specify the type of spark resistant construction with full recognition of the potential hazards and the degree of protection required.

Type C - The fan shall be so constructed that a shift of the wheel or shaft will not permit two ferrous parts of the fan to rub or strike. This is accomplished with an aluminum inlet cone and rub ring and is limited to 500°F. Construction to 800°F is available using a steel inlet cone with copper/bronze lining. Contact factory for construction to 1000°F.

Integral Inlet Cone Assembly

Includes four pieces of angle, welded to the insulated plug or mounting panel, which serve to pre-align the inlet funnel within the wheel. The entire unit can be installed or removed through the same hole in the customer's enclosure, without the need for additional mounting or alignment of the inlet cone.



Arrangement 1P

Belt drive arrangement where the fan is mounted to grade and the motor is mounted separate from the fan. Typically used on larger fans and/or larger HP motors where the customer's wall may not be sufficient by itself. Mounting to the foundation also makes it better for meeting lower vibration requirements. Mounting panel is optional on arrangement 1P.



Arrangement 4

Direct drive arrangement where the wheel is mounted to the motor shaft. The design is more compact and requires less maintenance due to not having fan shaft, bearings or belts. High airstream temperatures may limit the use of this arrangement.



Arrangement 8P

Direct drive arrangement where the motor shaft is coupled to the fan shaft. The entire assembly is mounted to grade. Typically used on larger fans and/or larger HP motors where the customer's wall may not be sufficient by itself. Mounting to the foundation also makes it better for meeting lower vibration requirements. Mounting panel is optional.

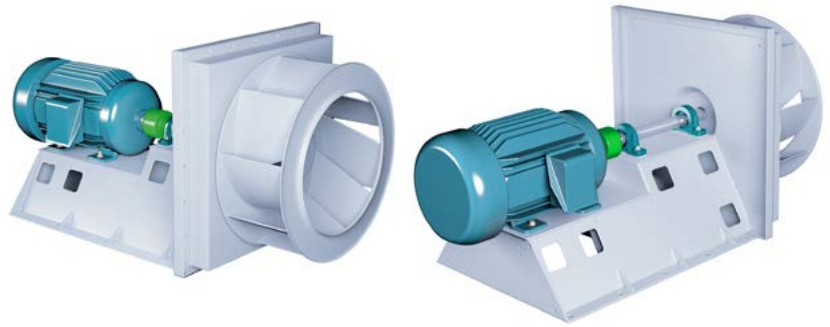
**Arrangement 9**

Arrangement 9 is the most common plug fan arrangement. It is fully supported by the customer's wall. Plug fans are housed in the customer's enclosure in applications where the system plenum acts as the fan housing. Unlike the plenum fan, motor, shaft and bearings are outside of the process airstream.

**Arrangement 9P**

Same as the arrangement 9 fan except the fan is mounted to grade. Typically used on larger fans and/or larger HP motors where the customer's wall may not be sufficient by itself. Mounting to the foundation also makes it better for meeting lower vibration requirements. Mounting panel is optional.

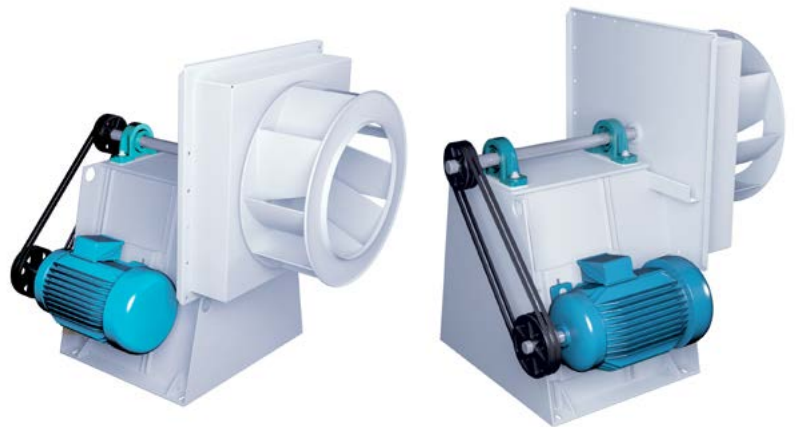

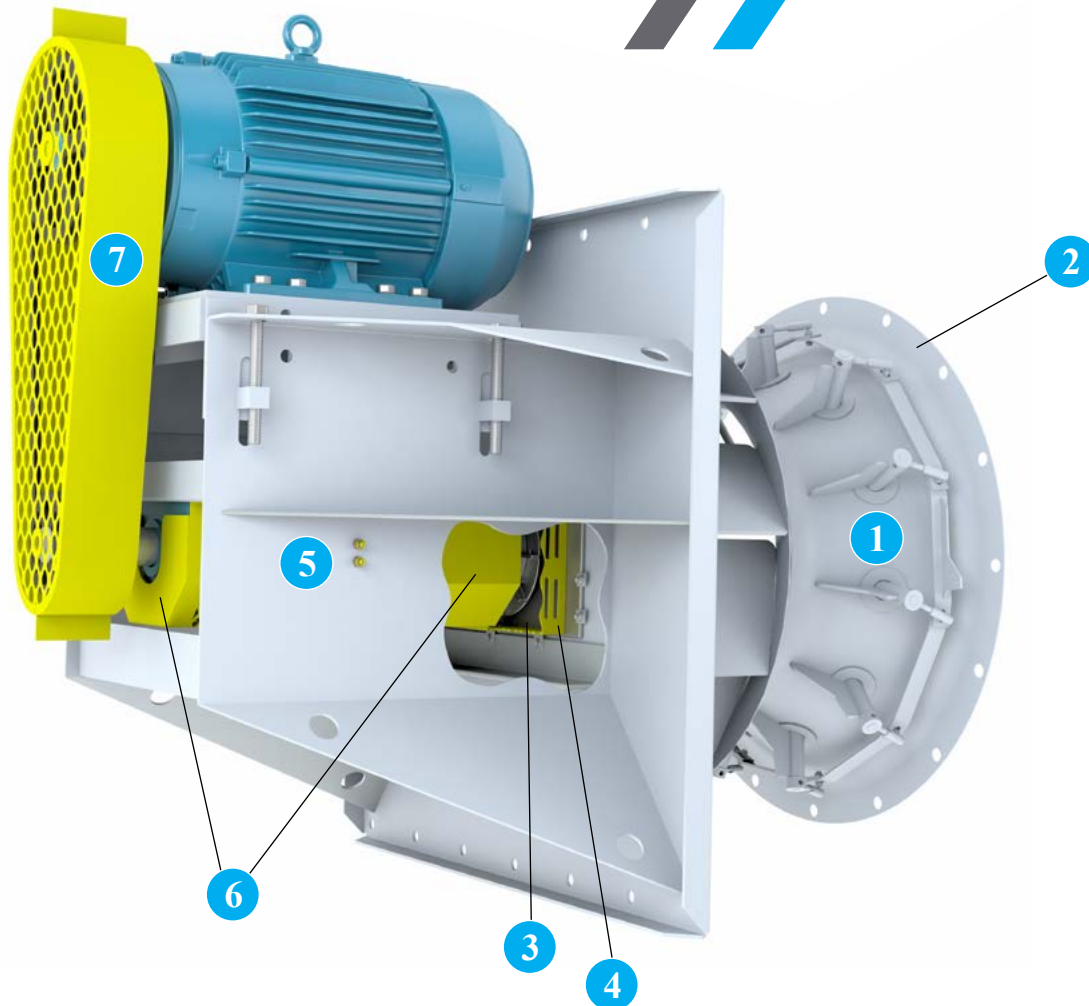

1 Variable Nested Inlet Vanes Vane blades are cantilever design or center supported, equipped with permanently lubricated bearings and ball joints for smooth and easy operation. See page 5 for more information.

2 Inlet Cones Heavy-gauge and spun to match the wheel intake rim to ensure smooth airflow. Inlet cone flange is prepunched for mounting. Inlet cones are shipped loose as standard. An integral inlet cone is optional.

3 Shaft Coolers Cast aluminum shaft cooler dissipates the heat transferred to the shaft from the airstream protecting the fan bearings. Recommended for applications over 300°F.

4 Shaft Seals reduce leakage and protect the bearings from a contaminated airstream. Standard seals are constructed of Tetraglas compressed between an aluminum cover plate and the fan housing. The standard shaft seal is not gas tight. Special seals are available for low leakage applications requiring more protection.

5 Extended Lube Lines Allow for easy lubrication of bearings on belt driven units without disassembly of guards by extending polyethylene lines from fan bearings to outside of guards or weather covers.

6 Shaft and Bearing Guards Sheet metal guards cover shaft and bearings and come with extended lube lines to a common point outside of the guard. A guard spanning the shaft between the bearings is available to provide open access to bearings for lubrication and vibration monitoring.

7 Belt Guards Belt guard protects personnel from the moving drive parts. OSHA and quick access guards are available.

Other Accessories Include:

- Piezometer Ring
- Inlet Screens
- Special Wheel Widths

Mounting is accomplished by providing a hole larger than the wheel diameter through the chamber wall. The wheel, shaft, motor and drive assembly is then positioned to the inlet cone (mounted in opposite wall) and secured in place. See Figure A.

Another method is to provide a hole sized only for the wheel drive shaft. The wheel is then positioned through the opening for the inlet cone after the drive and panel assembly has been securely mounted. See Figure B.

Plug fans may be applied with open wheel (unhoused) or with a housing as shown in Figure C. Performance data in this catalog is for unhoused wheel application.

Walls must be designed by the users to support the dynamic loads of the fan without resonance to eliminate vibration and bearing failure.

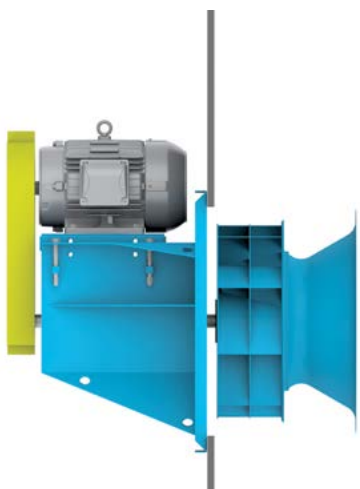

Figure A

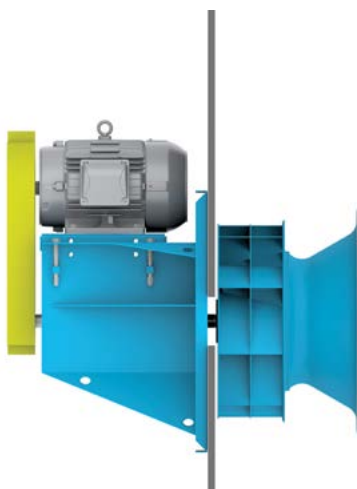
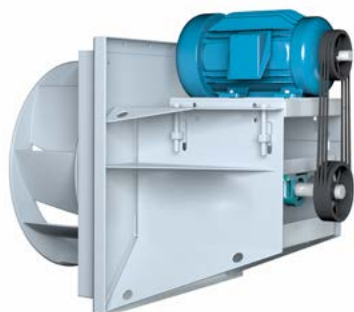

Figure B



Figure C
(shown with optional housing)

MOUNTING ARRANGEMENTS



Horizontal



Vertical Down



Vertical Up

To ensure proper motor selection, consideration must be given to starting torque requirements (fan wheel inertia WR^2) along with the operating BHP. Table 1 lists the WR^2 factors for different wheel sizes to be used in evaluating

the capability of a selected motor. In some cases it may be necessary to provide a larger horsepower motor, even though it may not be dictated by the operating BHP, to bring the fan to speed.

Table 1. Maximum Fan RPMs, Wheel Weights and WR^2

FAN SIZE	CLASS I					CLASS II				
	MAXIMUM RPM			WHEEL WT. (LBS)	WR^2 (LBS-FT ²)	MAXIMUM RPM			WHEEL WT. (LBS)	WR^2 (LBS-FT ²)
	STD.	4" PLUG	6" PLUG			STD.	4" PLUG	6" PLUG		
122	3167	3167	2512	15	1.7	4119	4119	3087	15	1.7
135	2874	2874	2364	17	2.4	3738	3738	2899	18	2.7
150	2587	2587	1908	20	3.7	3364	3364	2316	21	4.1
165	2352	2352	1779	24	5.7	3058	3058	2090	28	7.0
182	2118	2118	1520	31	8.8	2729	2729	2180	39	10.8
200	1932	1932	1800	38	12.5	2490	2490	2045	49	17.4
222	1737	1737	1419	66	23.6	2238	2238	1659	74	28.8
245	1577	1577	1247	81	38.3	2033	2033	1523	87	42.9
270	1397	1397	1397	94	56.4	1803	1803	1668	103	64.6
300	1257	1257	1257	113	88.8	1623	1623	1496	125	101
330	1143	1143	1097	151	149	1475	1475	1303	167	158
365	995	995	967	198	245	1283	1283	1283	214	260
402	903	903	903	244	361	1163	1163	1163	254	382
445	817	817	817	340	566	1052	1052	1052	392	692
490	742	742	742	393	816	956	956	956	455	1001

Table 2. Bare Fan and Accessory Weights

FAN SIZE	APPROXIMATE WEIGHTS (LBS.)				
	BARE FAN		INSULATED PLUG	HOUSING	INLET VANES
	CLASS II	CLASS III			
122	140	151	25	24	45
135	145	156	25	30	45
150	151	162	25	37	52
165	185	196	32	44	24
182	208	230	32	65	29
200	221	233	32	79	33
222	235	247	35	97	38
245	240	252	35	117	40
270	323	341	40	143	45
300	330	348	40	236	45
330	388	406	55	287	50
365	430	478	55	350	50
402	575	636	75	428	55
445	639	710	75	522	60
490	950	1040	95	634	65



Table 3. High Temperature Applications

TEMP. RANGE	BEARING TYPE	LUBRICATION	OTHER REQUIREMENTS
TO 300°F	BALL OR ROLLER	GREASE	STANDARD CONSTRUCTION
301 TO 500°F	EXPANSION AND NON-EXPANSION	HIGH TEMPERATURE GREASE	CERAMIC SHAFT SEAL, SHAFT COOLER
501 TO 800°F	EXPANSION AND NON-EXPANSION	HIGH TEMPERATURE GREASE	HIGH TEMPERATURE ALUMINUM PAINT 4" MINIMUM INSULATION REQUIRED BY TCF OR CUSTOMER CERAMIC SHAFT SEAL, SHAFT COOLER
801 TO 1000°F	EXPANSION AND NON-EXPANSION	HIGH TEMPERATURE GREASE	316 STAINLESS STEEL WHEEL AND SHAFT 6" MINIMUM INSULATION REQUIRED BY TCF OR CUSTOMER HIGH TEMPERATURE ALUMINUM PAINT CERAMIC SHAFT SEAL, SHAFT COOLER

Figure 1. Wheel and Plenum Arrangement

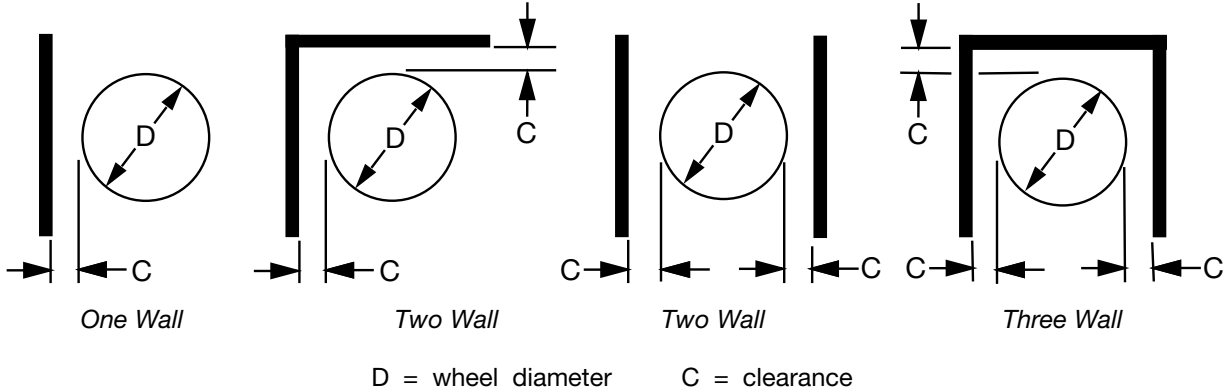

Table 4. Wall Proximity Factors

% WOV	FACTOR	C = D/8			C = D/4			C = D/2		
		ONE WALL	TWO WALL	THREE WALL	ONE WALL	TWO WALL	THREE WALL	ONE WALL	TWO WALL	THREE WALL
95	RPM	1.02	1.03	1.09	1.01	1.02	1.06	1.01	1.01	1.03
	BHP	1.06	1.08	1.29	1.04	1.06	1.20	1.02	1.02	1.08
85	RPM	1.02	1.02	1.08	1.01	1.02	1.06	1.01	1.01	1.03
	BHP	1.05	1.07	1.26	1.03	1.05	1.18	1.02	1.02	1.08
75	RPM	1.01	1.02	1.07	1.01	1.02	1.05	1.00	1.01	1.02
	BHP	1.04	1.06	1.23	1.03	1.05	1.16	1.01	1.02	1.07
65	RPM	1.01	1.02	1.06	1.01	1.01	1.04	1.00	1.01	1.02
	BHP	1.04	1.06	1.19	1.03	1.04	1.14	1.01	1.02	1.06
55	RPM	1.01	1.02	1.05	1.01	1.01	1.04	1.00	1.01	1.02
	BHP	1.03	1.05	1.16	1.02	1.03	1.12	1.01	1.02	1.05
45	RPM	1.01	1.01	1.04	1.01	1.01	1.03	1.00	1.00	1.01
	BHP	1.02	1.04	1.13	1.02	1.03	1.09	1.01	1.01	1.04

Table 5. WOV Factors

FAN SIZE	WOV FACTOR	D
122	1.18	12.25
135	1.58	13.50
150	2.16	15.00
165	2.88	16.50
182	3.87	18.25
200	5.09	20.00
222	7.01	22.25
245	9.36	24.50
270	12.58	27.00
300	17.26	30.00
330	22.97	33.00
365	31.40	36.50
402	42.11	42.25
445	56.91	44.50
490	75.97	49.00

Table 6. Temperature and Altitude Correction Factors

AIR TEMP °F	ALTITUDE IN FEET ABOVE SEA LEVEL												
	0	1000	2000	3000	4000	5000	6000	7000	8000	9000	10000	15000	20000
	BAROMETRIC PRESSURE IN INCHES OF MERCURY												
	29.92	28.86	27.82	26.82	25.84	24.90	23.98	23.09	22.22	21.39	20.58	16.89	13.75
70	1.000	0.964	0.930	0.896	0.864	0.832	0.801	0.772	0.743	0.714	0.688	0.564	0.460
100	0.946	0.912	0.880	0.848	0.818	0.787	0.758	0.730	0.703	0.676	0.651	0.534	0.435
150	0.869	0.838	0.808	0.770	0.751	0.723	0.696	0.671	0.646	0.620	0.598	0.490	0.400
200	0.803	0.774	0.747	0.720	0.694	0.668	0.643	0.620	0.596	0.573	0.552	0.453	0.360
250	0.747	0.720	0.694	0.669	0.645	0.622	0.598	0.576	0.555	0.533	0.514	0.421	0.344
300	0.697	0.672	0.648	0.624	0.604	0.580	0.558	0.538	0.518	0.498	0.480	0.393	0.321
350	0.654	0.631	0.608	0.586	0.565	0.544	0.524	0.505	0.486	0.467	0.450	0.369	0.301
400	0.616	0.594	0.573	0.552	0.532	0.513	0.493	0.476	0.458	0.440	0.424	0.347	0.283
450	0.582	0.561	0.542	0.522	0.503	0.484	0.466	0.449	0.433	0.416	0.401	0.328	0.268
500	0.552	0.532	0.513	0.495	0.477	0.459	0.442	0.426	0.410	0.394	0.380	0.311	0.254
550	0.525	0.506	0.488	0.470	0.454	0.437	0.421	0.405	0.390	0.375	0.361	0.296	0.242
600	0.500	0.482	0.469	0.448	0.432	0.416	0.400	0.386	0.372	0.352	0.344	0.282	0.230
650	0.477	0.460	0.444	0.427	0.412	0.397	0.382	0.368	0.354	0.341	0.328	0.269	0.219
700	0.457	0.441	0.425	0.410	0.395	0.380	0.366	0.353	0.340	0.326	0.315	0.258	0.210
800	0.420	0.404	0.389	0.375	0.362	0.350	0.336	0.323	0.311	0.300	0.290	0.237	0.193

Table 7. Derating Factors For High Temperature

TEMP. (°F)	STEEL		STAINLESS STEEL
	CLASS II		CLASS II
	121-281	321-491	
70	1.00	1.00	1.00
200	0.99	0.97	1.00
250	0.98	0.96	1.00
300	0.97	0.95	1.00
400	0.96	0.93	1.00
500	0.93	0.90	0.97
600	0.90	0.87	0.94
700	0.88	0.84	0.90
800	0.83	0.81	0.87
1000	N/A	N/A	0.81

When operating fans at elevated temperatures, the maximum RPMs of the fan from Table 1 on page 10 must be corrected to the safe operating RPM limit for the application using the factors listed in the Table 7.

The performance tables in this catalog are based on fans handling standard air at a density of 0.075 pounds per cubic foot. This is equivalent to air at 70°F at sea level (29.92 Hg barometric pressure). When specified performance is at a density different than standard, it must be converted to the equivalent standard conditions before the fan can be selected from the performance tables. The performance data and examples in this catalog are for unhooded BCPL plug fans.

Example 1. Standard Density

Given: 10894 CFM at 2.5" TSP (system). Installation is a two-wall arrangement with a wheel-to-wall clearance of 6¾".

Step 1. Entering the performance tables we find that a 270 BCPL plug fan will deliver 10894 CFM at 2.5" SP operating at 1178 RPM with 6.84 BHP.

Step 2. Catalog performance must be corrected for wheel-to-wall arrangement. Determine the wheel and plenum type from the arrangements shown in Figure 1 on page 5. Determine the clearance "C" based upon the closest wall. Performance will not be affected by any additional walls spaced greater than C x 3 from the wheel.

The selected 270 BCPL fan has a wheel diameter of 27" ("D"). Application is two walls with 6¾" clearance ("C"). Therefore, $C \div D = 6.75 \div 27 = 0.25$ or ¼" which is equivalent to $D \div 4$.

Step 3. Next, determine the Percent of Wide Open Volume (% WOV) at which the fan is to operate. From Table 2 on page 5 find that the WOV factor is 12.58 for a 270 BCPL fan.

$$\% \text{ WOV} = \frac{10894 \times 100}{1178 \times 12.48} = 73.5$$

Step 4. By interpolation from Table 1 on page 5, for the two wall column of $D \div 4$ at 73.5% WOV, we find the RPM factor of 1.02 and the BHP factor of 1.05.

Corrected unhooded performance for 10894 CFM at 2.5" SP standard air is:

$$\text{RPM} = 1178 \times 1.02 = 1201$$

$$\text{BHP} = 6.84 \times 1.05 = 7.18$$

Example 2. Nonstandard Density

Given: 10894 CFM at 2.5" TSP (system), 300°F, 3000 ft. altitude. Installation is a two-wall arrangement with a wheel-to-wall clearance of 6¾".

Step 1. To enter the performance tables the operating SP must be corrected to equivalent standard conditions. From Table 3 on page 5 find the correction factor of 0.624 for 300°F and 3000 feet altitude. The corrected equivalent static pressure is equal to:

$$\text{SP (Catalog)} = \frac{2.5" \text{ TSP (system)}}{0.624} = 4.0$$

Fan selection is then made for 10894 CFM at 4" SP. Entering the performance tables, we find that a 270 BCPL fan will deliver 10894 CFM at 1355 RPM with 10.18 BHP. It must be remembered that this BHP is cataloged at standard 70°F air at sea level.

Steps 2, 3 and 4. Continue the correction procedure with Steps 2, 3 and 4 as shown in Example 1. Wall arrangement = $D \div 4$, % WOV = 63.9, RPM = 1368 and BHP = 10.58.

Step 5. Standard air BHP must now be converted to the design conditions BHP. The BHP at 300°F and 3000 ft. altitude equals $10.58 \times$ the density factor of $0.624 = 6.6$ BHP.

It must be remembered to provide consideration to motor HP for 70°F air at 3000 ft. altitude to avoid motor overload at startup. Multiplying the altitude factor of 0.896 (for 70°F at 3000 ft.) x BHP (10.58) gives us 9.47.

Therefore, performance for the 270 BCPL fan for 10894 CFM at 2.5" SP, 300°F and 3000 ft. altitude is 1368 RPM, 6.6 operating BHP and 9.47 startup BHP.

Step 6. Maximum wheel RPMs must be checked for all elevated temperature applications. The derating factors for high temperature listed in Table 4 on page 5 must be applied to the maximum Class I and Class II RPMs listed in Table 5 on page 6. In this example the derating factor for 300°F is 0.96 and the maximum RPM for a Class I Size 270 BCPL is 1397 RPM. Therefore, the maximum RPM for this wheel is $1397 \times 0.96 = 1341$ RPM. The fan as selected is to operate at 1368 RPM which does not fall within this derated Class I maximum RPM, so a Class II fan must be considered. The maximum speed for a Class II size 270 BCPL is 1803 RPM. $1803 \times$ the derating factor of $0.96 = 1730$ RPM. 1368 RPM falls within this range so a Class II fan may be used.



122 BCPL

Wheel Dia.: 12.25"

Table with 14 columns (CFM, 0.5" SP, 1" SP, 1.5" SP, 2" SP, 2.5" SP, 3" SP, 3.5" SP, 4" SP, 4.5" SP, 5" SP, 6" SP, 7" SP, 8" SP) and 25 rows of performance data for the 122 BCPL fan.

135 BCPL

Wheel Dia.: 13.5"

Table with 14 columns (CFM, 0.5" SP, 1" SP, 1.5" SP, 2" SP, 2.5" SP, 3" SP, 3.5" SP, 4" SP, 4.5" SP, 5" SP, 6" SP, 7" SP, 8" SP) and 25 rows of performance data for the 135 BCPL fan.

150 BCPL

Wheel Dia.: 15"

Table with 14 columns (CFM, 0.5" SP, 1" SP, 1.5" SP, 2" SP, 2.5" SP, 3" SP, 3.5" SP, 4" SP, 4.5" SP, 5" SP, 6" SP, 7" SP, 8" SP) and 25 rows of performance data for the 150 BCPL fan.

Underlined figures indicate maximum static efficiency. Power rating (BHP) does not include transmission losses.

Regular type face = Class I Bold type face = Class II

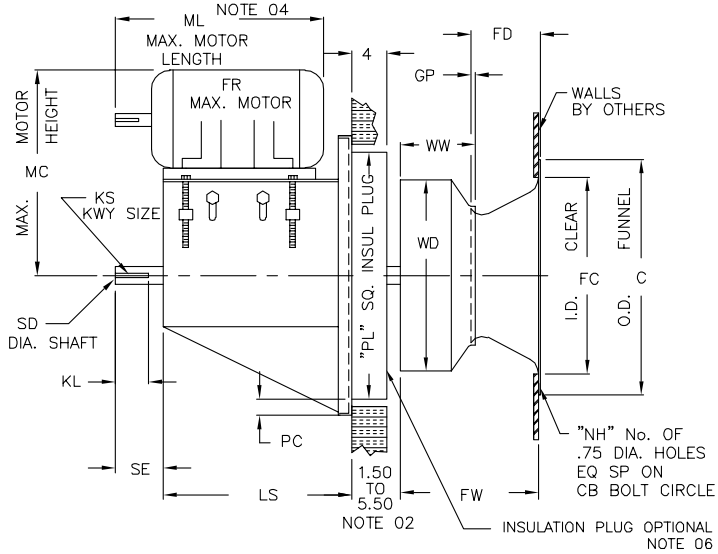
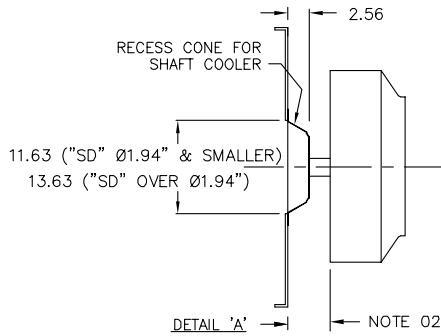
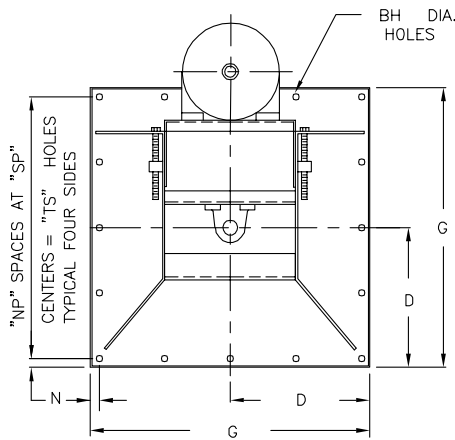

NOTES:

1. Dimensions apply to unboxed assembly only.
2. The minimum clearance between the wheel and insulated plug or mounting panel is 1.50" shaft is selected to include up to a 4" thick insulated plug without shaft change. Consult factory for larger than 4" thick insulated plug. See Detail "A" for shaft cooler recess cone and shaft seal on fans over 300°F with 4" or larger insulation plug or wall thickness.
3. CW rotation is standard. CCW rotation is optional.
4. To ensure selected motor will fit standard assembly, compare the maximum motor length, dimension "ML," to overall motor length.
5. Type BC wheel is standard on all sizes. Type BAF wheel is optional on sizes 182-490.
6. Customer to provide wall opening with adequate clearance for installation of wheel and insulation plug when provided.

FAN SIZE	BH	C	CB	D	FC	FD	FR	FW	G	GP	KL	KS	
												CL I	CL II
122	0.56	15.75	14.75	11.38	13.25	4.33	213T	8.71	22.75	0.31	4.00	.38x.19	.38x.19
135	0.56	16.75	15.75	11.38	14.56	4.76	213T	9.67	22.75	0.34	4.00	.38x.19	.38x.19
150	0.56	18.25	17.25	11.38	16.19	5.29	215T	10.73	22.75	0.38	4.00	.38x.19	.38x.19
165	0.56	20.00	19.00	14.81	17.75	5.85	215T	11.73	29.63	0.38	4.00	.38x.19	.38x.19
182	0.56	22.00	21.00	14.81	19.50	6.44	254T	12.94	29.63	0.47	4.50	.38x.19	.50x.25
200	0.56	24.38	23.38	14.81	21.38	7.05	254T	14.12	29.63	0.52	4.50	.38x.19	.50x.25
222	0.56	26.63	25.50	16.00	23.75	7.83	256T	15.77	32.00	0.55	4.50	.38x.19	.50x.25
245	0.56	28.63	27.75	16.00	27.00	8.62	256T	17.36	32.00	0.59	4.50	.38x.19	.50x.25
270	0.69	31.00	29.75	18.31	29.00	9.45	284T	19.00	36.63	0.67	5.00	.50x.25	.50x.25
300	0.69	34.88	33.63	18.31	31.62	10.50	284T	21.13	36.63	0.75	5.00	.50x.25	.50x.25
330	0.69	38.50	37.25	21.81	34.75	11.57	286T	23.29	43.63	0.82	5.00	.50x.25	.50x.25
365	0.69	42.00	40.75	21.81	39.50	12.84	286T	26.06	43.63	0.72	5.50	.50x.25	.63x.31
402	0.69	45.38	44.13	27.50	42.50	14.28	326T	28.85	55.00	0.90	5.50	.50x.25	.63x.31
445	0.69	49.88	48.63	27.50	47.25	15.81	326T	31.91	55.00	1.00	5.50	.63x.31	.63x.31
490	0.69	54.38	53.13	27.50	52.00	17.38	326T	35.04	55.00	1.10	5.50	.63x.31	.63x.31

FAN SIZE	LS	MC	ML	N	NH	NP	PC	PL	SD		SE	SP	TS	WD	WW
									CL I	CL II					
122	17.50	24.25	19.13	1.00	8.00	4.00	1.75	19.25	1.437	1.687	5.00	5.19	20.75	12.25	4.75
135	17.50	24.25	19.13	1.00	8.00	4.00	1.75	19.25	1.437	1.687	5.00	5.19	20.75	13.50	5.31
150	18.50	24.25	20.13	1.00	8.00	4.00	1.75	19.25	1.437	1.687	5.00	5.19	20.75	15.00	5.88
165	18.50	24.25	20.13	1.00	8.00	4.00	1.81	26.00	1.437	1.687	5.00	6.91	27.63	16.50	6.38
182	21.00	27.50	24.13	1.00	8.00	4.00	1.81	26.00	1.437	1.937	5.50	6.91	27.63	18.25	7.12
200	21.00	27.50	24.13	1.00	8.00	4.00	1.81	26.00	1.687	1.937	5.50	6.91	27.63	20.00	7.75
222	22.50	27.50	25.50	1.00	8.00	4.00	1.88	28.25	1.687	1.937	5.50	7.50	30.00	22.25	8.69
245	22.50	27.50	25.50	1.00	8.00	4.00	1.88	28.25	1.687	1.937	5.50	7.50	30.00	24.50	9.56
270	23.00	29.50	26.63	1.00	8.00	6.00	2.25	32.13	1.937	2.187	6.00	5.77	34.63	27.00	10.50
300	23.00	29.50	26.63	1.00	16.00	6.00	2.25	32.13	1.937	2.187	6.00	5.77	34.63	30.00	11.69
330	24.50	29.50	28.13	1.00	16.00	6.00	2.38	38.88	1.937	2.187	6.00	6.94	41.63	33.00	12.88
365	24.50	29.50	28.13	1.00	16.00	6.00	2.38	38.88	1.937	2.437	6.50	6.94	41.63	36.50	14.25
402	27.50	33.00	31.25	1.00	16.00	6.00	3.38	48.25	2.187	2.437	6.50	8.83	53.00	40.25	15.69
445	27.50	33.00	31.25	1.00	16.00	6.00	3.38	48.25	2.437	2.687	6.50	8.83	53.00	44.50	17.31
490	27.50	33.00	31.25	1.00	16.00	6.00	2.50	50.00	2.437	2.687	6.50	8.83	53.00	49.00	19.00

Dimensions are not to be used for construction. Certified drawings are available upon request.

AC11107L

Arrangement 9

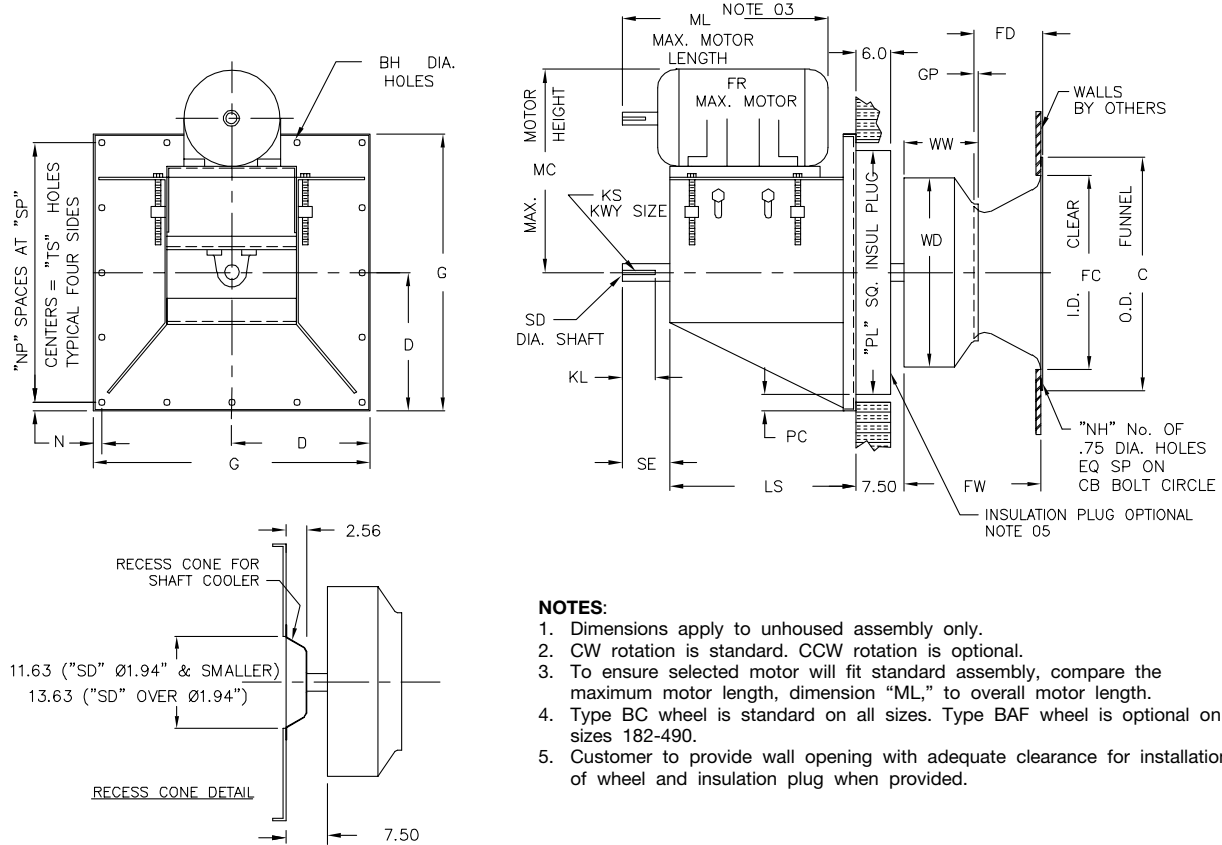

- NOTES:**
1. Dimensions apply to unhoused assembly only.
 2. CW rotation is standard. CCW rotation is optional.
 3. To ensure selected motor will fit standard assembly, compare the maximum motor length, dimension "ML," to overall motor length.
 4. Type BC wheel is standard on all sizes. Type BAF wheel is optional on sizes 182-490.
 5. Customer to provide wall opening with adequate clearance for installation of wheel and insulation plug when provided.

FAN SIZE	BH	C	CB	D	FC	FD	FR	FW	G	GP	KL	KS		LS
												CL I	CL II	
122	0.56	15.75	14.75	11.38	13.25	4.38	213T	8.69	22.75	0.31	4.00	.38x.19	.38x.19	17.50
135	0.56	16.75	15.75	11.38	14.56	4.81	213T	9.69	22.75	0.38	4.00	.38x.19	.38x.19	17.50
150	0.56	18.25	17.25	11.38	16.19	5.38	215T	10.81	22.75	0.38	4.00	.38x.19	.38x.19	18.50
165	0.56	20.00	19.00	14.81	17.75	5.94	215T	11.81	29.63	0.44	4.00	.38x.19	.38x.19	18.50
182	0.56	22.00	21.00	14.81	19.50	6.56	254T	13.06	29.63	0.56	4.50	.38x.19	.50x.25	21.00
200	0.56	24.38	23.38	14.81	21.38	7.19	254T	14.25	29.63	0.63	4.50	.38x.19	.50x.25	21.00
222	0.56	26.63	25.50	16.00	23.75	8.00	256T	15.94	32.00	0.69	4.50	.38x.19	.50x.25	22.50
245	0.56	28.63	27.75	16.00	27.00	8.81	256T	17.50	32.00	0.75	4.50	.38x.19	.50x.25	22.50
270	0.69	31.00	29.75	18.31	29.00	9.69	284T	19.31	36.63	0.88	5.00	.50x.25	.50x.25	23.00
300	0.69	34.88	33.63	18.31	31.62	10.75	284T	21.44	36.63	1.00	5.00	.50x.25	.50x.25	23.00
330	0.69	38.50	37.25	21.81	34.75	11.81	286T	23.56	43.63	1.06	5.00	.50x.25	.50x.25	24.50
365	0.69	42.00	40.75	21.81	39.50	13.06	286T	26.25	43.63	0.94	5.50	.50x.25	.63x.31	24.50
402	0.69	45.38	44.13	27.50	42.50	14.44	326T	28.94	55.00	1.06	5.50	.50x.25	.63x.31	27.50
445	0.69	49.88	48.63	27.50	47.25	15.94	326T	32.00	55.00	1.13	5.50	.63x.31	.63x.31	27.50
490	0.69	54.38	53.13	27.50	52.00	17.56	326T	35.31	55.00	1.25	5.50	.63x.31	.63x.31	27.50

FAN SIZE	MC	ML	N	NH	NP	PC	PL	SD		SE	SP	TS	WD	WW	MAX. SAFE SHAFT SPEED	
								CL I	CL II						CL I	CL II
122	24.25	19.13	1.00	8.00	4.00	1.75	19.25	1.437	1.687	5.00	5.19	20.75	12.25	4.69	2512	3087
135	24.25	19.13	1.00	8.00	4.00	1.75	19.25	1.437	1.687	5.00	5.19	20.75	13.50	5.31	2364	2899
150	24.25	20.13	1.00	8.00	4.00	1.75	19.25	1.437	1.687	5.00	5.19	20.75	15.00	5.88	1908	2316
165	24.25	20.13	1.00	8.00	4.00	1.81	26.00	1.437	1.687	5.00	6.91	27.63	16.50	6.38	1779	2090
182	27.50	24.13	1.00	8.00	4.00	1.81	26.00	1.437	1.937	5.50	6.91	27.63	18.25	7.13	1520	2180
200	27.50	24.13	1.00	8.00	4.00	1.81	26.00	1.687	1.937	5.50	6.91	27.63	20.00	7.75	1800	2045
222	27.50	25.50	1.00	8.00	4.00	1.88	28.25	1.687	1.937	5.50	7.50	30.00	22.25	8.69	1419	1659
245	27.50	25.50	1.00	8.00	4.00	1.88	28.25	1.687	1.937	5.50	7.50	30.00	24.50	9.50	1247	1523
270	29.50	26.63	1.00	8.00	6.00	2.25	32.13	1.937	2.187	6.00	5.77	34.63	27.00	10.56	1397	1668
300	29.50	26.63	1.00	16.00	6.00	2.25	32.13	1.937	2.187	6.00	5.77	34.63	30.00	11.75	1257	1496
330	29.50	28.13	1.00	16.00	6.00	2.38	38.88	1.937	2.187	6.00	6.94	41.63	33.00	12.88	1097	1303
365	29.50	28.13	1.00	16.00	6.00	2.38	38.88	1.937	2.437	6.50	6.94	41.63	36.50	14.19	967	1283
402	33.00	31.25	1.00	16.00	6.00	3.38	48.25	2.187	2.437	6.50	8.83	53.00	40.25	15.63	903	1163
445	33.00	31.25	1.00	16.00	6.00	3.38	48.25	2.437	2.687	6.50	8.83	53.00	44.50	17.25	817	1052
490	33.00	31.25	1.00	16.00	6.00	2.50	50.00	2.437	2.687	6.50	8.83	53.00	49.00	19.00	742	956

Dimensions are not to be used for construction. Certified drawings are available upon request.

AC15384D

Fan Housing Details

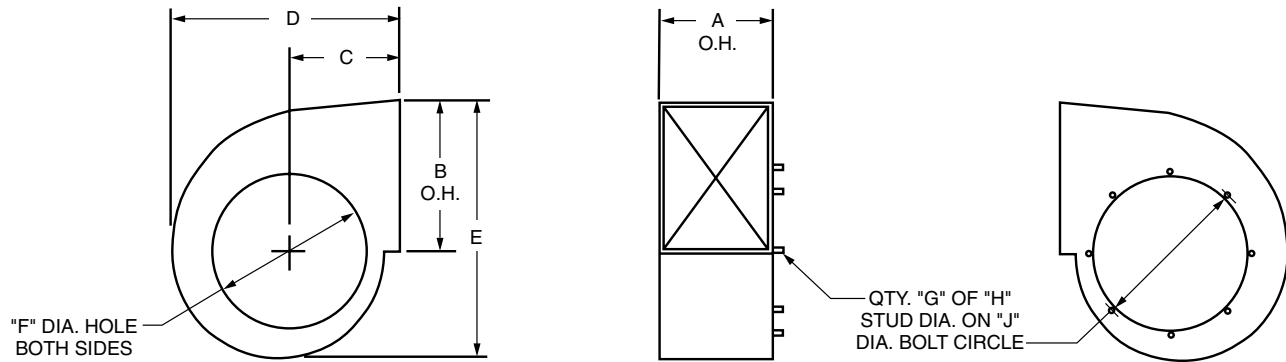

NOTE: Rotation must be specified as viewed from drive side to ensure proper location of inlet cone mounting studs. Studs provided on inlet side only.

FAN SIZE	HOUSING DIMENSIONS (IN.)								
	A	B	C	D	E	F	G	H	J
122	9 ³ / ₄	13	9 ¹ / ₄	19 ¹³ / ₁₆	22 ¹ / ₄	13 ³ / ₄	8	³ / ₈	14 ³ / ₄
135	10 ¹³ / ₁₆	14 ⁵ / ₁₆	10 ¹ / ₄	21 ⁷ / ₈	24 ¹ / ₂	14 ⁹ / ₁₆	8	³ / ₈	15 ³ / ₄
150	11 ¹⁵ / ₁₆	15 ⁷ / ₈	11 ⁷ / ₁₆	24 ⁵ / ₁₆	27 ³ / ₁₆	16 ³ / ₁₆	8	³ / ₈	17 ¹ / ₄
165	13 ³ / ₁₆	17 ⁷ / ₁₆	12 ⁵ / ₈	26 ³ / ₄	29 ⁷ / ₈	17 ³ / ₄	8	³ / ₈	19
182	14 ⁹ / ₁₆	19 ³ / ₈	14	29 ¹¹ / ₁₆	33 ³ / ₈	19 ¹ / ₂	8	³ / ₈	21
200	15 ¹⁵ / ₁₆	21 ³ / ₁₆	15 ⁵ / ₁₆	32 ⁵ / ₈	36 ⁵ / ₁₆	21 ³ / ₈	8	³ / ₈	23 ³ / ₈
222	17 ¹¹ / ₁₆	23 ⁹ / ₁₆	17 ⁷ / ₁₆	36 ¹ / ₄	40 ⁵ / ₁₆	23 ³ / ₄	8	³ / ₈	25 ¹ / ₂
245	19 ⁷ / ₁₆	25 ¹⁵ / ₁₆	19	40	44 ³ / ₈	27	8	³ / ₈	27 ³ / ₄
270	21 ³ / ₈	28 ⁵ / ₈	20 ⁵ / ₁₆	44 ¹ / ₈	49	29	8	³ / ₈	29 ³ / ₄
300	23	31 ¹³ / ₁₆	23 ³ / ₁₆	49 ¹ / ₁₆	54 ⁷ / ₁₆	31 ⁵ / ₈	16	³ / ₈	33 ⁵ / ₈
330	25 ¹ / ₄	35 ⁵ / ₈	25 ³ / ₄	54 ¹ / ₈	60	34 ³ / ₄	16	³ / ₈	37 ¹ / ₄
365	27 ³ / ₄	38 ¹¹ / ₁₆	28 ¹ / ₂	60	66 ⁵ / ₁₆	39 ¹ / ₂	16	³ / ₈	40 ³ / ₄
402	30 ³ / ₈	42 ⁵ / ₈	31 ¹ / ₂	66 ³ / ₁₆	73 ¹ / ₁₆	42 ¹ / ₂	16	³ / ₈	44 ¹ / ₈
445	33 ⁷ / ₁₆	47 ¹ / ₈	34 ⁷ / ₈	73 ¹ / ₈	80 ³ / ₄	47 ¹ / ₄	16	³ / ₈	48 ⁵ / ₈
490	36 ⁷ / ₁₆	51 ¹⁵ / ₁₆	38 ¹ / ₂	80 ¹¹ / ₁₆	89	52	16	³ / ₈	53 ¹ / ₈

Dimensions are not to be used for construction. Certified drawings are available upon request.

Belt Centers

MOTOR FRAME SIZE	FAN SIZE							
	122-165		182-245		270-365		402-490	
	MIN	MAX	MIN	MAX	MIN	MAX	MIN	MAX
143T	13	16 ¹ / ₂	14	17 ¹ / ₂	14 ¹ / ₂	18	16	19 ¹ / ₂
145T								
182T	14	17 ¹ / ₂	15	18 ¹ / ₂	15 ¹ / ₂	19	17	20 ¹ / ₂
184T								
213T	14 ³ / ₄	18 ¹ / ₄	15 ³ / ₄	19 ¹ / ₄	16 ¹ / ₄	19 ³ / ₄	17 ³ / ₄	21 ¹ / ₄
215T								
254T			16 ³ / ₄	20 ¹ / ₄	17 ¹ / ₄	20 ³ / ₄	18 ³ / ₄	22 ¹ / ₄
256T								
284T					18	21 ¹ / ₂	19 ¹ / ₂	23
286T								
324T							20 ¹ / ₂	24
326T								



Recirculation Fans in Paint Finishing System





Model BCPL

Fans shall be Model BCPL Flat Blade BI SWSI Plug Fans, as manufactured by Twin City Fan & Blower, Minneapolis, Minnesota.

PERFORMANCE — Fans shall be tested and rated in accordance with industry accepted test codes and shall be guaranteed by the manufacturer to deliver rated published performance levels.

PLUG PANEL — Plug panel shall be of minimum 7 gauge steel with formed flanges to maintain flatness and rigidity. Panel shall be prepunched for bolt mounting. Panel assembly may also be welded in place. The “Cross Frame” bearing support is designed for maximum stability and load spreading. Bearings are serviceable without disassembly of panel or frame. Plug assembly is available for both horizontal and vertical application. Horizontal construction is standard. Vertical construction must be specified.

WHEEL — BCPL wheels shall be backward inclined, non-overloading, single thickness plate type, designed for maximum efficiency and quiet operation. Wheels shall be constructed of heavy-gauge steel, welded to both the back plate and rim. Wheels shall have tapered spun wheel cones or shrouds, providing stable flow and high rigidity.

Optional backward inclined airfoil blade wheels shall use die-formed airfoil blades continuously welded to the rim and back plate. Clockwise or counterclockwise rotation is available. Specify rotation as viewed from drive side.

SHAFT — Shafts shall be AISI 1040 or 1045 hot rolled steel accurately turned, ground, polished and ring gauged for accuracy. Shafts shall be sized for a first critical speed of at least 1.43 times the maximum speed for the class.

BEARINGS — Bearings shall be either ball or spherical roller, heavy-duty, self-aligning, pillow block type. Bearing selection is based upon L-10 minimum life of 40,000 hours or average life of 200,000 hours.

OPTIONAL ALL WELDED HOUSING — Housing shall be of heavy-gauge steel. Housing shall be provided with wheel opening on each side and weld studs on inlet side for cone mounting. Specify rotation and discharge as viewed from drive side to ensure proper stud placement. Housing supports and attachments for wall mounting to be provided by others.

ADJUSTABLE MOTOR BASE — Adjustable motor base is standard and shall have a four point leveling and tension adjustment to ensure proper drive belt alignment. The motor base shall be heavy-gauge steel and prepunched to accept standard motor frame specified.

OPTIONAL INLET VANES — Inlet vane blades are cantilever design with supports equipped with permanently lubricated needle bearings and ball joints for smooth and easy operation. Vane assemblies are external type for sizes 122 through 150 and nested for sizes 165 through 490. Standard inlet vanes are applicable to 300°F. Consult factory for higher temperatures and dimensions.

FACTORY RUN TEST — All fans prior to shipment shall be completely assembled and test run as a unit at the specified operating speed or maximum RPM allowed for the particular construction type. Each wheel shall be statically and dynamically balanced in accordance with ANSI/AMCA 204-96 “Balance Quality and Vibration Levels for Fans” to Fan Application Category BV-3, Balance Quality Grade G6.3. Balance readings shall be taken by electronic type equipment in the axial, vertical and horizontal directions on each of the bearings. Records shall be maintained and a written copy shall be available upon request.

GUARANTEE — The manufacturer shall guarantee the workmanship and materials for its BCPL Flat Blade BI SWSI Plug Fans for at least one (1) year from startup or eighteen (18) months from shipment, whichever occurs first.

Model

BEPL (High Efficiency Plug Fans)

Sizes

12" to 49" wheel diameters (305 mm to 1,245 mm)

Performance

Airflow to 76,000 CFM (129,100 m³/hour)
Static pressure to 12" w.g. (2,980 Pa)

Features

SWSI backward curved, non-overloading, single thickness airfoil type wheels



See Catalog 355 for more information

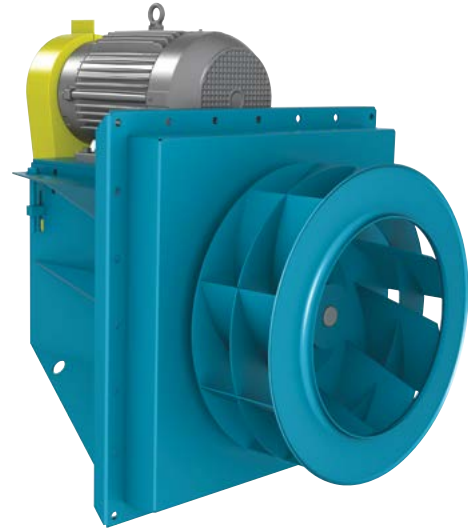

BEPL Arrangement 9 – Pedestal Plug Fan

Model

BFPL (Plug Fans)

Sizes

12.4" to 49.21" wheel diameters (315 mm to 1,250 mm)

Performance

Airflow to 76,000 CFM (129,100 m³/hour)
Static pressure to 12" w.g. (2,980 Pa)

Features

SWSI backward curved, non-overloading, single thickness airfoil type wheels



See Catalog 360 for more information

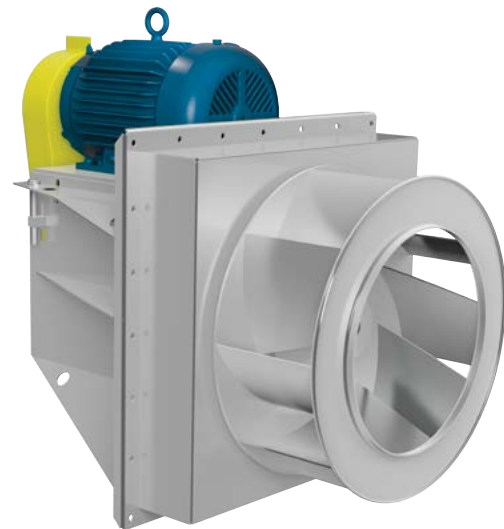

BFPL Arrangement 9

INDUSTRIAL PROCESS AND COMMERCIAL VENTILATION SYSTEMS

CENTRIFUGAL FANS | UTILITY SETS | PLENUM & PLUG FANS | INLINE CENTRIFUGAL FANS
MIXED FLOW FANS | TUBEAXIAL & VANEAXIAL FANS | PROPELLER WALL FANS | PROPELLER ROOF VENTILATORS
CENTRIFUGAL ROOF & WALL EXHAUSTERS | CEILING VENTILATORS | GRAVITY VENTILATORS | DUCT BLOWERS
RADIAL BLADED FANS | RADIAL TIP FANS | HIGH EFFICIENCY INDUSTRIAL FANS | PRESSURE BLOWERS
LABORATORY EXHAUST FANS | FILTERED SUPPLY FANS | MANCOOLERS | FIBERGLASS FANS | CUSTOM FANS



TWIN CITY FAN & BLOWER
WWW.TCF.COM

5959 TRENTON LANE N | MINNEAPOLIS, MN 55442 | PHONE: 763-551-7600 | FAX: 763-551-7601

©2020 Twin City Fan Companies, Ltd., Minneapolis, MN. All rights reserved. Catalog illustrations cover the general appearance of Twin City Fan & Blower products at the time of publication and we reserve the right to make changes in design and construction at any time without notice.