



INDUSTRIAL PROCESS AND
COMMERCIAL VENTILATION SYSTEMS

FIBERGLASS CENTRIFUGAL FANS

Model BAFF





Overview

BAFF



Model BAFF,
Arr. 9

The BAFF fiberglass fan is a backward inclined industrial fan designed for handling corrosive or caustic air in high pressure applications where conventional steel and stainless steel fans would corrode. Typical industries that utilize this style of fan include pulp and paper, steel processing, petrochemical plants and wastewater treatment facilities. All of the parts that are exposed to the airstream are constructed of high-quality corrosion resistant materials to avoid material breakdown from most chemicals.

Advantages of Fiberglass Fans

- Superior corrosion resistance to gases, fumes and vapors
- Lower maintenance costs
- More economical than stainless steel construction
- Lighter weight than steel

Wheel Design

The fiberglass "FA" wheel design features a backward inclined airfoil blade. This wheel offers a power limiting characteristic with the added advantages of high operating efficiency and low noise level.

Sizes and Performance

12" to 39" wheel diameters
Airflow to 31,100 CFM
Static pressure to 13" w.g.

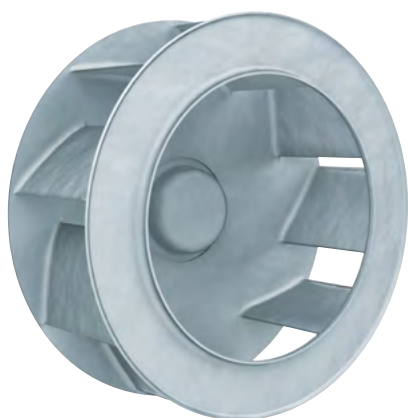

Backward Inclined Airfoil
Fiberglass Wheel



For complete product performance, drawings and available accessories, download our Fan Selector program at tcf.com.

Accessories

BAFF

Raised Bolted Cleanout Door Door is fiberglass laminate, gasketed and positioned at three or nine o'clock opposite the fan discharge.

Weather Cover (Arr. 10) Provides complete protection from the elements for the shaft, bearings, motor and drive.

OSHA Type Belt Guard (Arr. 1 & 9) Provides complete coverage of belts and sheaves for maximum protection of personnel. Includes a tachometer opening for checking the fan speed.

Shaft & Bearing Guard (Arr. 1 & 9) Solid sheet metal enclosure designed to cover the shaft and bearings. Grease lines are accessible for lubrication purposes.

Flanged Inlet Heavy fiberglass flange; drilling optional.

Unitary Base (Arr. 1 & 9) Unitary bases offered in all sizes. Bases are constructed of structural channel in the following sizes:

Size 12" - 20" 3" channel

Size 25" - 39" 5" channel

Vibration Isolation Rubber-in-shear or spring isolators available for all sizes and arrangements.

Housing Drain Provided with a 1" female pipe thread at low point of scroll.

Shaft Seal Heavy Teflon element with 316 stainless steel back plate seals against 316 stainless shaft for maximum protection.



STANDARD CONFIGURATIONS

CLOCKWISE (CW) - ROTATION & DISCHARGE (ROTATION VIEW FROM DRIVE SIDE)

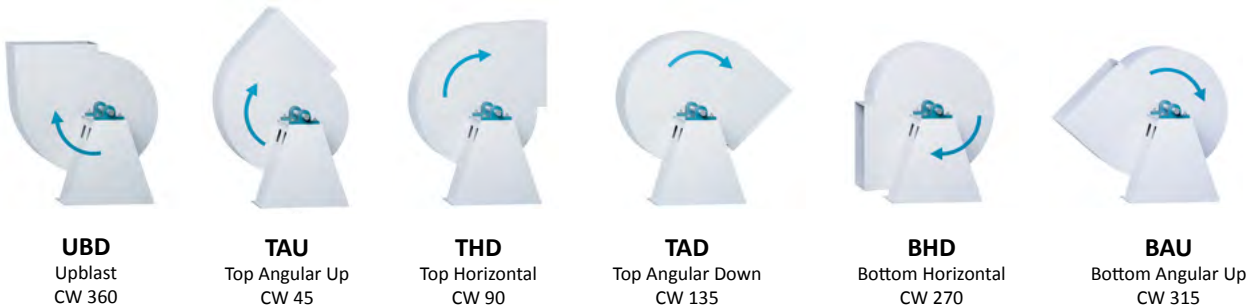

COUNTER CLOCKWISE (CCW) - ROTATION & DISCHARGE (ROTATION VIEW FROM DRIVE SIDE)

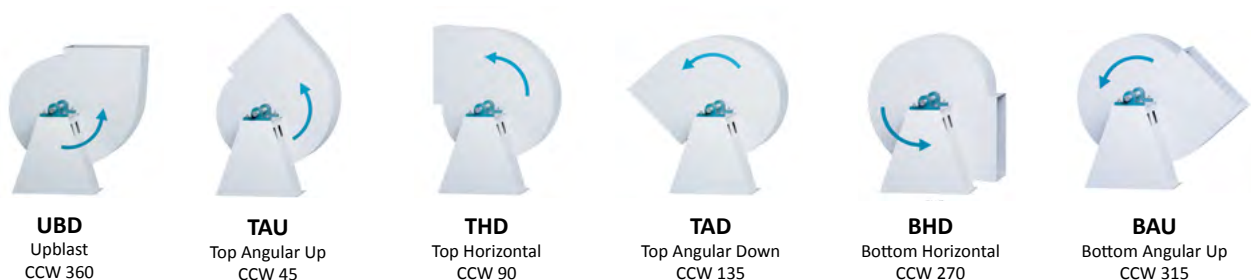



Corrosion Resistant

All airstream parts of fiberglass reinforced polyester with resistance to most chemicals. The wheel is constructed of vinyl ester fiberglass resin as standard. Standard construction meets ASTM 84 flame spread rating of 25 or less. Housing construction of vinyl ester is available as an option. See "Optional Construction" below and the "Corrosion Resistance Guide" on page 7.

Non-Overloading Power Characteristic

Prevents motor overload under variable operating conditions. The aluminum hub and carbon steel shaft assembly are bolted to a fiberglass wheel and completely coated with fiberglass laminate for maximum corrosion protection.

Aluminum Hub

Hub and carbon steel shaft assembly bolted to a fiberglass wheel and completely coated with fiberglass laminate for maximum corrosion protection.

Shaft Hole Closure

Thin Teflon membrane secured with a 316 SS steel plate to minimize housing leakage.

Inlet Connection

Slip-type connection is standard.

All-Welded Steel Base

Arrangements 9 and 10 are provided with a slide rail motor base for ease in adjusting belt tension. All steel parts are finished with an air dry epoxy paint.

Flanged Outlet

Integral flanged outlet is furnished as standard; drilling is optional.

Rotation

Clockwise rotation is standard, counter-clockwise rotation is available as an option.

Arrangements & Sizes

Six fan sizes, 12" through 39", are available in arrangements 1, 9 and 10.

Product Finish

All fiberglass parts are coated inside and outside with resin (with UV inhibitor), approximately 10 mils in thickness, to seal and provide protection from ultraviolet light. This results in a smooth, high gloss finish. All steel parts are finished with an air dry epoxy paint.

OPTIONAL CONSTRUCTION

Special Fiberglass Materials

Please contact the factory to ensure a suitable material is selected for the specific application.

- **Vinyl Ester** — Provides increased corrosion resistance to stronger acids, chlorine and oxidizing agents. For use in industrial applications such as chemical and water treatment plants, and commercial applications where urban or salt air corrosion exists. The wheel is constructed of vinyl ester fiberglass resin as standard. Housing construction of vinyl ester is available as an option.
- **Surface Veil** — Produces a smooth reinforced final surface with greater corrosion resistance and contains a UV inhibitor to provide protection from ultraviolet rays.
- **Fire-Retardant Resin** — Reduces the resin's tendency to burn by achieving a flame-spread rating of 25 or less.

Spark Resistant Construction

Spark resistant construction for fiberglass fans is recommended when the fan is handling explosive fumes. Although fiberglass is a non-sparking material, it can build and retain a static charge that can be potentially hazardous. With spark resistant construction, the fan is statically grounded by graphite impregnation to reduce a static charge buildup.





Arrangement 1

Arrangement 1 fans are available in either direct drive or belt driven installations. The belt driven configuration allows the motor to be mounted in any of the four standard motor positions shown below. The choice of a belt driven installation provides greater performance flexibility with the use of belts and sheaves of differing sizes. Maximum temperature is 200°F.



Arrangement 9

Arrangement 9 fans include a motor slide base mounted on the side of the motor pedestal. The motor and drive can be installed at the factory or field installed. Maximum temperature is 200°F.

Unless otherwise specified, the motor will be installed on the left (L) side of the pedestal on CW fans and on the right (R) side on CCW fans.



Arrangement 10

Arrangement 10 fans are suitable for roof or outdoor installations. A weather cover, not shown, provides complete weather protection for motor, shaft, bearings and drives. Larger fan sizes in this arrangement, or larger motor sizes for smaller fans, may be available on special request from the factory. All usual accessories are available in this arrangement. Maximum temperature is 200°F.

MOTOR POSITIONS

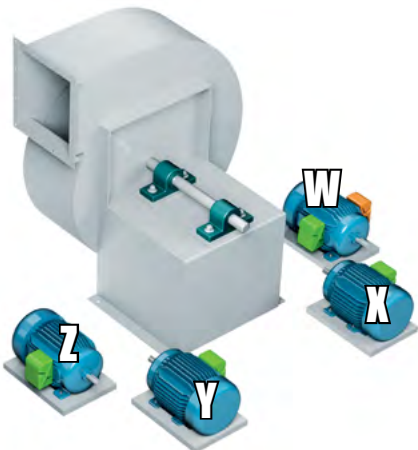

Arrangements 1



Arrangement 9

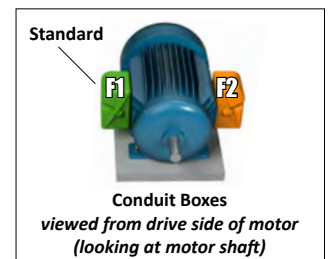

Standard

F1

F2

Conduit Boxes
viewed from drive side of motor
(looking at motor shaft)

PERFORMANCE CORRECTION FOR TEMPERATURE & ALTITUDE

The performance tables in this catalog are based on standard air conditions of 70°F at sea level (0.075 lbs./cu. ft. density). If the performance of the fan is based on standard conditions, the fan can be selected directly from the performance tables in this catalog.

When a fan operates at temperatures other than 70°F or altitudes other than sea level, a “temperature and altitude density ratio” (Table 1) is used to convert these conditions to standard air conditions. This conversion must be done before the fan can be selected from the performance tables in this catalog. After the fan is selected at standard conditions, the temperature correction ratio must be used to convert the brake horsepower at standard air conditions to the brake horsepower at operating conditions. This is shown in the example below.

Example: A Size 25 BAFF is to provide 7,060 CFM at 2.5" SP, at 150°F at 1,000 ft. elevation (0.0628 lbs./cu. ft. density).

For 150°F and 1,000 ft. elevation, the temperature and altitude density ratio table shows a density ratio of 0.838. Using the temperature and altitude density ratio, the static pressure at standard conditions is determined as follows:

$$\text{Operating SP} \div \frac{\text{Temp. \& Alt.}}{\text{Density Ratio}} = \text{SP at Std. Conditions}$$

$$2.5" \text{ SP} \div 0.838 = 3" \text{ SP at Standard Conditions}$$

Turn to page 9 for the Size 25 BAFF fan performance table. Using 7,060 CFM at 3" SP at standard conditions, find the RPM and brake horsepower to be 1,463 RPM and 5.21 BHP. **Note:** 5.21 BHP is the brake horsepower required at standard conditions and is also referred to as the “cold brake horsepower” or “starting brake horsepower.”

The actual brake horsepower at the operating condition of 150°F and 1,000 ft. elevation is determined by the following equation:

$$\frac{\text{BHP at Std. Conditions}}{\text{Density Ratio}} \times \frac{\text{Temp. \& Alt.}}{\text{Density Ratio}} = \text{BHP at Oper. Conditions}$$

$$5.21 \times 0.838 = 4.36 \text{ BHP at Operating Conditions}$$

Therefore, the Size 25 BAFF fan providing 7,060 CFM at 2.5" SP, at 150°F and 1,000 ft. elevation will run at 1,463 RPM and will require 4.36 BHP at operating conditions and 5.21 BHP at starting.

Table 1. Temperature and Altitude Density Ratios

AIR TEMP °F	ALTITUDE IN FEET ABOVE SEA LEVEL											
	0	1000	2000	3000	4000	5000	6000	7000	8000	9000	10000	15000
	BAROMETRIC PRESSURE IN INCHES OF MERCURY											
	29.92	28.86	27.82	26.82	25.84	24.90	23.98	23.09	22.22	21.39	20.58	16.89
-50	1.293	1.247	1.201	1.159	1.116	1.076	1.036	0.997	0.960	0.924	0.889	0.729
0	1.152	1.111	1.071	1.032	0.995	0.959	0.923	0.889	0.856	0.824	0.792	0.650
50	1.039	1.003	0.967	0.932	0.897	0.864	0.833	0.801	0.772	0.743	0.715	0.586
70	1.000	0.964	0.930	0.896	0.864	0.832	0.801	0.772	0.743	0.714	0.688	0.564
100	0.946	0.912	0.880	0.848	0.818	0.787	0.758	0.730	0.703	0.676	0.651	0.534
150	0.869	0.838	0.808	0.770	0.751	0.723	0.696	0.671	0.646	0.620	0.598	0.490
200	0.803	0.774	0.747	0.720	0.694	0.668	0.643	0.620	0.596	0.573	0.552	0.453

Maximum Safe Speeds

When operating at temperatures other than 70°F, the maximum speed of the fan is affected. To determine the maximum speed at the operating temperature, a “Maximum Safe Speed Temperature Factor” (Table 3) is applied to the “Maximum Safe Wheel Speed at 70°F” (Table 2).

Table 2. Maximum Safe Wheel Speed at 70°F

SIZE	CL I	CL II	CL III
12	3080	4005	5083
16	2425	3153	4002
20	1941	2523	3046
25	1540	2002	2372

Table 3. Maximum Safe Speed Temperature Factors

TEMPERATURE		FACTOR
°F	°C	
70	21	1.00
100	38	1.00
150	66	0.85
200	93	0.55

Example: The maximum safe speed for a Class I Size 25 BAFF operating at 150°F is 1,309 RPM. The calculation is shown below.

$$\frac{\text{Max. RPM at 70°F}}{\text{Temp. Factor (Table 3)}} = \text{Max. RPM at Operating Temp.}$$

$$1,540 \times 0.85 = 1,309 \text{ Class I Max. RPM at 150°F}$$

Since the Class I Max. RPM at 150°F is 1,309, the fan in our previous example running at 1,463 RPM and 150°F would require Class II construction.

Table 4. Metric Conversion Factors

DESCRIPTION	ENGLISH UNIT	METRIC UNIT	CONVERSION FACTOR	
			ENGLISH TO METRIC	METRIC TO ENGLISH
VOLUME	CFM	m³/s	0.000472	2118.90
PRESSURE	in. w.g.	kPa	0.24866	4.02156
POWER	BHP	kW	0.74570	1.3410
VELOCITY	fpm	m/s	0.00508	196.85
SPEED	RPM	rps	0.01667	60.00
AREA	ft²	m²	0.09290	10.7640
CIRCUMFERENCE	ft	m	0.30480	3.2808
DIAMETER	in.	mm	25.400	0.03937

CORROSION RESISTANCE GUIDE

The following table lists gases, fumes and vapors that are commonly exhausted from chemical processes. Using the "Legend of Symbols," the table indicates how Twin City Fan & Blower's standard fiberglass fans will withstand exhausting the particular gas, fume or vapor.

This data is based on a maximum temperature of 200°F (93°C).

Legend of Symbols

- S — Satisfactory Application
- L — Limited Life or Life Tests Incomplete
- U — Unsatisfactory

APPLICATION	SATURATED VAPOR	DRY VAPOR	EXCESS DRY AIR	APPLICATION	SATURATED VAPOR	DRY VAPOR	EXCESS DRY AIR
ACIDS				ALKALINE SALTS			
Acetic	L	S	S	Sodium Bicarbonate	L	S	S
Aqua Regia	U	U	L	Sodium Carbonate	L	S	S
Boric	S	S	S	Sodium Chloride	L	S	S
Butyric	S	S	S	Sodium Cyanide	L	S	S
Carbonic	S	S	S	Trisodium, Phosphate	L	L	S
Chromic	S	S	S	ALKALIS			
Citric	S	S	S	Ammonium Hydroxide	U	L	S
Formic	L	S	S	Calcium Hydroxide	U	L	S
Hydrochloric	S	S	S	Potassium Hydroxide	U	L	S
Hydrocyanic	L	S	S	Sodium Hydroxide	U	L	S
*Hydrofluoric	L	S	S	Sodium Hypochlorite	U	L	S
Hypochlorous	L	S	S	KETONES			
Lactic	S	S	S	Acetone	U	L	S
Maleic	S	S	S	Methyl Ethyl Ketone	U	U	L
Nitric	L	S	S	Methyl Isobutyl Ketone	U	U	L
Oleic	S	S	S	ESTERS			
Oxalic	S	S	S	Butyl Acetate	U	L	S
Perchloric	U	U	U	Ethyl Acetate	U	U	S
Phosphoric	S	S	S	Zinc Acetate	S	S	S
Picric	L	S	S	GASES			
Stearic	S	S	S	Ammonia	L	S	S
Sulfuric	S	S	S	Bromine	U	U	U
Sulfurous	S	S	S	Carbon Dioxide	S	S	S
Tannic	S	S	S	Carbon Disulfide	L	L	S
Tartaric	S	S	S	Chlorine	L	S	S
SALTS, ACID & NEUTRAL				*Fluorine	L	S	S
Alum	S	S	S	*Hydrogen Fluoride	L	S	S
Aluminum Chloride	S	S	S	Hydrogen Sulfide	S	S	S
Aluminum Sulphate	S	S	S	Sulfur Dioxide	S	S	S
Ammonium Chloride	S	S	S	HYDROCARBONS			
Ammonium Nitrate	S	S	S	Benzene	U	U	U
Ammonium Sulphate	S	S	S	Fuel Oil	S	S	S
Calcium Chloride	S	S	S	Gasoline	S	S	S
Calcium Sulphate	S	S	S	Kerosene	S	S	S
Copper Chloride	S	S	S	Lubricating Oil	S	S	S
Copper Sulphate	S	S	S	Mineral Oil	S	S	S
Ferric Chloride	S	S	S	Toluene	U	U	U
Ferric Nitrate	S	S	S	Vegetable Oil	S	S	S
Ferric Sulphate	S	S	S	Naphtha	S	S	S
Magnesium Salts	S	S	S	Methane	S	S	S
Nickel Salts	S	S	S	Butane	S	S	S
Potassium Chloride	S	S	S	Propane	S	S	S
Potassium Nitrate	S	S	S	Xylol	S	S	S
Potassium Sulphate	S	S	S	CHLORINATED SOLVENTS			
Sodium Chloride	S	S	S	Carbon Tetrachloride	L	S	S
Sodium Sulphate	S	S	S	Chlorobenzene	U	U	U
Sodium Sulphite	S	S	S	Chloroform	U	U	U
Stannous Chloride	S	S	S	Perchloroethylene	U	U	L
Zinc Chloride	S	S	S	Trichloroethylene	U	U	L
Zinc Sulphate	S	S	S	GLYCOLS			
ALCOHOLS	S	S	S		S	S	S

* Surface finished with Synthetic Surfacing Veil Required.

To identify a specific fan for ordering or engineering specification, it is necessary to show the complete catalog number as shown to the right. All performance data is available in curve form upon request.

All capacities shown in the performance tables that follow are for standard air conditions: 70°F at sea level (.075 lbs./cu. ft. air density).

The performance tables shown are given in English units. To use the performance tables for metric values, refer to "Metric Conversion Factors" (Table 4) on page 6.

Catalog Numbering System

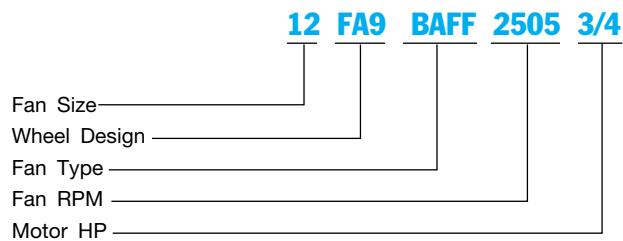

BAFF Size 12 FA9

Wheel Diameter: 12.4"
 Wheel Circumference: 3.25 ft.

Outlet Area: 0.88 sq. ft.
 Max. BHP: 0.052 (RPM ÷ 1000)³

CFM	OV	1/2" SP		1" SP		1½" SP		2" SP		2½" SP		3" SP		3½" SP		4" SP		5" SP	
		RPM	BHP	RPM	BHP	RPM	BHP	RPM	BHP	RPM	BHP	RPM	BHP	RPM	BHP	RPM	BHP	RPM	BHP
880	1000	1325	0.117	1586	0.209	1819	0.306	2034	0.412	2233	0.528	2420	0.651	2598	0.782	2768	0.919		
1320	1500	1729	0.233	1940	0.362	2126	0.497	2297	0.634	2459	0.777	2615	0.922	2766	1.07	2910	1.23	3186	1.56
1760	2000	2165	0.424	2344	0.59	2504	0.761	2651	0.937	2789	1.12	2922	1.30	3048	1.48	3171	1.67	3410	2.06
2200	2500	2618	0.713	2771	0.917	2913	1.13	3045	1.34	3168	1.55	3285	1.77	3397	2.00	3507	2.22	3716	2.68
2640	3000	3081	1.130	3215	1.37	3340	1.61	3459	1.87	3571	2.12	3679	2.37	3782	2.63	3881	2.90	4069	3.43
3080	3500	3551	1.69	3669	1.97	3781	2.25	3888	2.54	3991	2.83	4089	3.12	4185	3.42	4277	3.72	4453	4.33
3520	4000	4026	2.42	4131	2.74	4232	3.06	4329	3.39	4423	3.72	4514	4.05	4602	4.38	4687	4.72	4852	5.40
3960	4500	4504	3.35	4598	3.71	4690	4.07	4779	4.43	4865	4.80	4949	5.17						
4400	5000	4984	4.50																

CFM	OV	6" SP		7" SP		8" SP		9" SP		10" SP		11" SP		12" SP		13" SP		14" SP	
		RPM	BHP	RPM	BHP	RPM	BHP	RPM	BHP	RPM	BHP	RPM	BHP	RPM	BHP	RPM	BHP	RPM	BHP
880	1000																		
1320	1500	3445	1.92	3691	2.29	3926	2.69	4153	3.10	4370	3.53								
1760	2000	3638	2.45	3857	2.86	4067	3.29	4270	3.75	4466	4.22	4655	4.71	4840	5.21				
2200	2500	3916	3.15	4109	3.62	4297	4.11	4480	4.60	4658	5.10	4832	5.62						
2640	3000	4251	3.97	4425	4.52	4593	5.07	4757	5.64	4918	6.21								
3080	3500	4619	4.94	4778	5.56	4934	6.20												
3520	4000																		
3960	4500																		
4400	5000																		

Class I

Class II

Class III

Performance shown is with inlet and outlet ducts. BHP shown does not include drive losses.

BAFF Size 16 FA9

Wheel Diameter: 15.75"
 Wheel Circumference: 4.12 ft.

Outlet Area: 1.42 sq. ft.
 Max. BHP: 0.17 (RPM ÷ 1000)³

CFM	OV	1/2" SP		1" SP		1½" SP		2" SP		2½" SP		3" SP		3½" SP		4" SP		5" SP	
		RPM	BHP	RPM	BHP	RPM	BHP	RPM	BHP	RPM	BHP	RPM	BHP	RPM	BHP	RPM	BHP	RPM	BHP
1420	1000	1044	0.189	1249	0.337	1432	0.494	1601	0.664	1758	0.851	1905	1.05	2046	1.26	2180	1.48		
2130	1500	1362	0.376	1528	0.584	1674	0.801	1808	1.02	1936	1.25	2059	1.49	2177	1.73	2292	1.98	2508	2.52
2840	2000	1704	0.683	1845	0.951	1972	1.23	2087	1.51	2196	1.80	2300	2.09	2400	2.39	2497	2.70	2685	3.32
3550	2500	2061	1.15	2182	1.48	2294	1.82	2397	2.16	2495	2.51	2587	2.86	2675	3.22	2761	3.58	2926	4.32
4260	3000	2426	1.82	2531	2.21	2630	2.61	2723	3.01	2812	3.42	2897	3.83	2978	4.25	3056	4.68	3204	5.53
4970	3500	2796	2.72	2889	3.17	2977	3.63	3062	4.10	3142	4.57	3220	5.04	3295	5.52	3368	6.01	3506	6.98
5680	4000	3170	3.90	3253	4.42	3332	4.94	3409	5.47	3483	6.00	3554	6.53	3624	7.08	3691	7.62	3821	8.72
6390	4500	3547	5.41	3621	5.99	3693	6.57	3763	7.16	3831	7.75	3897	8.35	3961	8.94				
7100	5000	3925	7.27	3992	7.91														

CFM	OV	6" SP		7" SP		8" SP		9" SP		10" SP		11" SP		12" SP		13" SP		14" SP	
		RPM	BHP	RPM	BHP	RPM	BHP	RPM	BHP	RPM	BHP	RPM	BHP	RPM	BHP	RPM	BHP	RPM	BHP
1420	1000																		
2130	1500	2712	3.09	2906	3.70	3091	4.34	3269	5.00	3440	5.70								
2840	2000	2864	3.95	3037	4.62	3202	5.32	3362	6.05	3516	6.81	3665	7.59	3811	8.41	3952	9.23		
3550	2500	3083	5.08	3235	5.85	3383	6.62	3528	7.42	3668	8.23	3804	9.06	3937	9.93				
4260	3000	3347	6.41	3484	7.29	3617	8.19	3746	9.10	3872	10.03	3997	10.97						
4970	3500	3637	7.98	3762	8.98	3885	10.00												
5680	4000	3944	9.83																
6390	4500																		
7100	5000																		

Class I

Class II

Class III

Performance shown is with inlet and outlet ducts. BHP shown does not include drive losses.

BAFF Size 20 FA9

Wheel Diameter: 19.68"
Wheel Circumference: 5.15 ft.

Outlet Area: 2.22 sq. ft.
Max. BHP: 0.53 (RPM ÷ 1000)³

CFM	OV	1/2" SP		1" SP		1 1/2" SP		2" SP		2 1/2" SP		3" SP		3 1/2" SP		4" SP		5" SP	
		RPM	BHP	RPM	BHP	RPM	BHP	RPM	BHP	RPM	BHP	RPM	BHP	RPM	BHP	RPM	BHP	RPM	BHP
2220	1000	836	0.296	1000	0.527	1147	0.773	1282	1.04	1407	1.33	1525	1.64	1637	1.97	1744	2.32		
3330	1500	1091	0.589	1224	0.915	1340	1.25	1448	1.60	1550	1.96	1649	2.33	1743	2.70	1834	3.09	2008	3.93
4440	2000	1366	1.07	1478	1.49	1580	1.92	1672	2.37	1759	2.82	1842	3.27	1922	3.74	1999	4.21	2150	5.19
5550	2500	1651	1.80	1748	2.32	1837	2.84	1920	3.38	1998	3.92	2072	4.48	2142	5.04	2211	5.61	2343	6.76
6660	3000	1944	2.85	2028	3.46	2107	4.08	2182	4.71	2253	5.35	2320	5.99	2385	6.65	2447	7.31	2566	8.65
7770	3500	2241	4.27	2315	4.97	2385	5.69	2453	6.42	2517	7.15	2580	7.90	2640	8.65	2698	9.40	2808	10.92
8880	4000	2540	6.12	2606	6.92	2670	7.74	2731	8.56	2790	9.39	2847	10.22	2903	11.07	2957	11.93	3060	13.63
9990	4500	2842	8.47	2901	9.37	2959	10.29	3015	11.21	3069	12.13	3122	13.07	3173	14.00				
11100	5000	3145	11.39	3199	12.39														

CFM	OV	6" SP		7" SP		8" SP		9" SP		10" SP		11" SP		12" SP		13" SP		14" SP	
		RPM	BHP	RPM	BHP	RPM	BHP	RPM	BHP	RPM	BHP	RPM	BHP	RPM	BHP	RPM	BHP	RPM	BHP
2220	1000																		
3330	1500	2171	4.83	2326	5.79	2474	6.78	2617	7.83	2753	8.90								
4440	2000	2293	6.18	2431	7.21	2563	8.31	2691	9.45	2814	10.64	2934	11.87	3050	13.13	3164	14.44		
5550	2500	2469	7.94	2590	9.14	2709	10.36	2824	11.60	2936	12.86	3045	14.17	3152	15.53				
6660	3000	2681	10.03	2790	11.40	2896	12.80	2999	14.23	3100	15.67	3200	17.15						
7770	3500	2913	12.48	3013	14.05	3111	15.64												
8880	4000	3159	15.38																
9990	4500																		
11100	5000																		

Class I Class II Class III Performance shown is with inlet and outlet ducts. BHP shown does not include drive losses.

BAFF Size 25 FA9

Wheel Diameter: 24.8"
Wheel Circumference: 6.49 ft.

Outlet Area: 3.53 sq. ft.
Max. BHP: 1.68 (RPM ÷ 1000)³

CFM	OV	1/2" SP		1" SP		1 1/2" SP		2" SP		2 1/2" SP		3" SP		3 1/2" SP		4" SP		5" SP	
		RPM	BHP	RPM	BHP	RPM	BHP	RPM	BHP	RPM	BHP	RPM	BHP	RPM	BHP	RPM	BHP	RPM	BHP
3530	1000	664	0.471	794	0.839	910	1.23	1017	1.65	1117	2.12	1210	2.61	1299	3.13	1384	3.68		
5295	1500	866	0.936	972	1.46	1064	1.99	1150	2.55	1231	3.12	1309	3.70	1384	4.30	1456	4.92	1594	6.26
7060	2000	1085	1.71	1174	2.37	1254	3.06	1328	3.77	1397	4.48	1463	5.21	1526	5.95	1587	6.70	1706	8.24
8825	2500	1312	2.87	1389	3.69	1459	4.52	1525	5.38	1587	6.25	1645	7.12	1701	8.01	1756	8.92	1860	10.75
10590	3000	1545	4.54	1611	5.51	1674	6.50	1733	7.50	1789	8.51	1843	9.55	1894	10.58	1944	11.64		
12355	3500	1780	6.79	1839	7.92	1895	9.06	1948	10.21	2000	11.39								

CFM	OV	6" SP		7" SP		8" SP		9" SP		10" SP		11" SP		12" SP		13" SP		14" SP	
		RPM	BHP	RPM	BHP	RPM	BHP	RPM	BHP	RPM	BHP	RPM	BHP	RPM	BHP	RPM	BHP	RPM	BHP
3530	1000																		
5295	1500	1723	7.68	1846	9.20	1963	10.77												
7060	2000	1820	9.82	1930	11.48														
8825	2500	1960	12.62																

Class I Class II Class III Performance shown is with inlet and outlet ducts. BHP shown does not include drive losses.



Arrangements 1 & 9

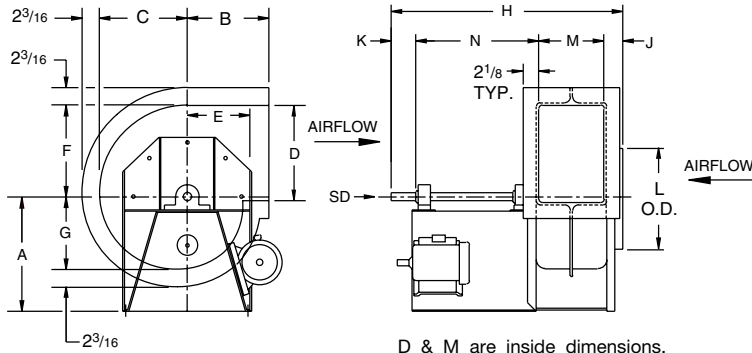

D & M are inside dimensions.
Arr. 1 without motor. Arr. 9 with motor.

BASE DETAIL - PLAN VIEW

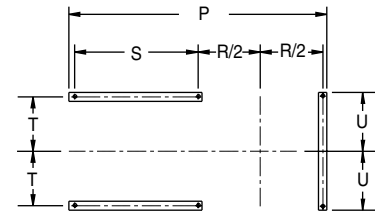

SIZE 12, 16, 20 & 25

SIZE	A	B	C	D	a	b	c	d	E	F	G	H
12	17.31	12.56	12.81	13.56	12.00	18.31	13.19	9.63	8.22	13.38	10.75	32.69
16	23.63	14.81	16.22	17.31	15.13	22.38	16.69	12.13	10.41	16.94	13.50	41.94
20	24.81	17.50	20.19	21.75	18.81	27.25	20.88	15.13	12.88	21.09	16.84	46.63
25	30.31	21.22	25.34	27.44	23.63	33.75	26.19	19.00	16.19	26.94	20.72	55.50

SIZE	J	K	SD	L	M	N	P	R	S	T	U	BASE HOLE DIA.	MAX.* MOTOR FRAME
12	3.44	2.50	1.00	14.75	9.19	17.56	28.69	11.81	15.25	7.75	8.75	0.56	184T
16	3.44	3.75	1.19	18.50	11.63	23.13	36.69	14.25	20.81	9.75	10.78	0.56	254T
20	3.50	5.38	1.50	22.81	14.63	23.13	39.69	17.25	20.81	11.88	12.91	0.56	284T
25	5.50	6.00	1.69	29.00	18.50	25.50	46.44	21.63	22.69	15.00	16.00	0.69	324T

Dimensions are not to be used for construction.

*Arr. 9 only

Arrangement 10

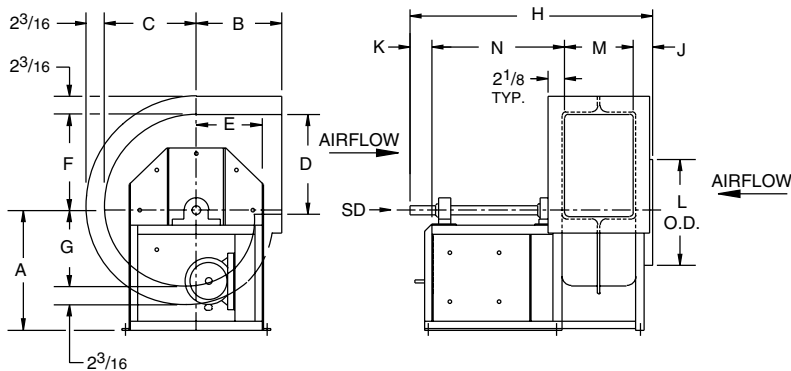

D & M are inside dimensions.

BASE DETAIL - PLAN VIEW

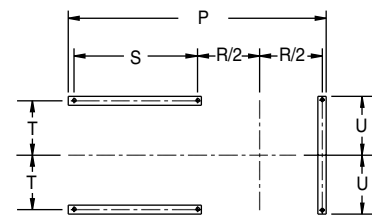

SIZE 12, 16, 20 & 25

SIZE	A	B	C	D	a	b	c	d	E	F	G	H
12	21.25	12.56	12.19	13.56	12.00	18.31	13.19	9.63	8.22	13.38	10.75	33.31
16	23.63	14.81	16.22	17.31	15.13	22.38	16.69	12.13	10.41	16.94	13.50	42.00
20	26.50	17.50	20.19	21.75	18.81	27.25	20.88	15.13	12.88	21.09	16.84	47.69
25	29.00	21.22	24.34	27.44	23.63	33.75	26.19	19.00	16.19	26.47	20.72	55.44

SIZE	J	K	SD	L	M	N	P	R	S	T	U	BASE HOLE DIA.	MAX.* MOTOR FRAME
12	3.44	2.50	1.00	14.75	9.19	18.19	30.81	11.81	17.38	9.50	10.13	0.56	184T
16	3.44	4.00	1.19	18.50	11.63	21.19	36.25	14.25	20.38	11.53	12.16	0.56	215T
20	3.50	3.75	1.50	22.81	14.63	25.19	43.31	17.38	24.25	13.59	14.22	0.56	256T
25	5.50	4.38	1.69	29.00	18.50	26.44	49.44	21.50	25.50	16.94	17.81	0.69	286T

Dimensions are not to be used for construction.



Model BAFF

Fans shall be Model BAFF SWSI Backward Inclined Airfoil Industrial Centrifugal type, as manufactured by Twin City Fan & Blower, Minneapolis, Minnesota, and shall be of the size and capacity as indicated in the fan schedule. Centrifugal fans shall be tested and rated in accordance with industry accepted test codes, and are guaranteed by the manufacturer to deliver rated performance. In addition, each unit shall be factory run tested prior to shipment.

HOUSING — The housing shall have all airstream parts of corrosion resistant fiberglass reinforced polyester resin mounted on an all welded, heavy-gauge steel base in Arrangement 1, 9 or 10. All airstream hardware shall be of stainless steel for maximum corrosion resistance.

WHEEL — The type FA9 BIA wheel shall be constructed using glass cloth impregnated with vinyl ester resin. The aluminum hub and carbon steel shaft (316 SS available) assembly shall be bolted to the fiberglass wheel and completely coated with fiberglass laminate for maximum corrosion protection. Wheels shall be statically and dynamically balanced.

BEARINGS — Bearings shall be of a regreasable pillow block type and shall have a minimum L-10 life as defined by AFBMA of at least 40,000 hours (200,000 hours average life).

DRIVES — The belts and sheaves furnished by the manufacturer shall be selected to provide a minimum 1.4 SF when measured against motor horsepower.

MOTOR — Fan motors shall be foot mounted NEMA Design B, heavy duty industrial, continuous duty, ball bearing, variable torque type suitable for operation on voltage, phase and hertz, as listed in the fan schedule. Motor bearings shall have a minimum L-10 life as defined by AFBMA of at least 40,000 hours (200,000 hours average life).

BALANCING — The propeller assembly shall be statically and dynamically balanced in accordance with ANSI/AMCA 204-96 “Balance Quality and Vibration Levels for Fans” to Fan Application Category BV-3, Balance Quality Grade G6.3. In addition, belt driven fan propellers shall be balanced on the fan shaft after final assembly in the fan casing, in the manufacturing facility, to the following peak velocity values, filter-in, at the fan test speed:

Fan Application Category	Rigidly Mounted (in./s)	Flexibly Mounted (in./s)
BV-3	0.15	0.20

FINISH — All steel parts are finished with an air dry epoxy paint. All fiberglass parts are coated inside and outside with resin (with UV inhibitor), approximately 10 mils in thickness, to seal the surface and provide a smooth, shiny finish. Optional resins and finishes include:

- Vinyl Ester
- Surface Veil
- Silica Sand - Airstream Only
- Fire-Retardant Resin

ACCESSORIES — The fan(s) shall be furnished complete with:

- Raised Bolted Cleanout Door
- Weather Cover (Arr. 10)
- OSHA Type Belt Guard (Arr. 1 & 9)
- Shaft & Bearing Guard (Arr. 1 & 9)
- Flanged Inlet (Drilled/Undrilled)
- Flanged Outlet (Drilled)
- Unitary Base (Arr. 1 & 9)
- Vibration Isolation (RIS/Spring)
- Housing Drain
- Shaft Seal
- Spark Resistant Construction
- 316 SS Shaft with Shaft Seal

INDUSTRIAL PROCESS AND COMMERCIAL VENTILATION SYSTEMS

CENTRIFUGAL FANS | UTILITY SETS | PLENUM & PLUG FANS | INLINE CENTRIFUGAL FANS
MIXED FLOW FANS | TUBEAXIAL & VANEAXIAL FANS | PROPELLER WALL FANS | PROPELLER ROOF VENTILATORS
CENTRIFUGAL ROOF & WALL EXHAUSTERS | CEILING VENTILATORS | GRAVITY VENTILATORS | DUCT BLOWERS
RADIAL BLADED FANS | RADIAL TIP FANS | HIGH EFFICIENCY INDUSTRIAL FANS | PRESSURE BLOWERS
LABORATORY EXHAUST FANS | FILTERED SUPPLY FANS | MANCOOLERS | FIBERGLASS FANS | CUSTOM FANS



TWIN CITY FAN & BLOWER
WWW.TCF.COM

5959 TRENTON LANE N | MINNEAPOLIS, MN 55442 | PHONE: 763-551-7600 | FAX: 763-551-7601

©2018 Twin City Fan Companies, Ltd., Minneapolis, MN. All rights reserved. Catalog illustrations cover the general appearance of Twin City Fan & Blower products at the time of publication and we reserve the right to make changes in design and construction at any time without notice.