



PowerTrap[®]

MODEL GP5C

SECONDARY PRESSURE DRAINER FOR PUMPING APPLICATIONS

Benefits

Pump with a linear inlet/outlet and low filling head. Ideal for low flow condensate removal from vented receivers situated at a low level in open systems.

1. No cavitation or seal leakage.
2. Non-electric design with durable compression spring for reliable performance.
3. Extremely low filling head. (min. 6")
4. Compact design and linear inlet/outlet reduce installation space, time and cost.
5. Easy, inline access to internal parts simplifies cleaning and reduces maintenance costs.
6. High-quality stainless steel internals and hardened working surfaces ensure reliability.
7. Float resists shock to 1600 psig.



Specifications

Model		GP5C	
Body Material		Cast Iron	Cast Stainless Steel
Connection	Pumped Medium Inlet & Outlet	Screwed	
	Motive Medium & Pump Exhaust	Screwed	
Size (in)	Pumped Medium: Inlet x Outlet	1" x 1"	
	Motive Medium Inlet	1/2	
	Pump Exhaust Outlet	1/4	
Maximum Operating Pressure (psig)	PMO	75	
Maximum Operating Temperature (°F)	TMO	365	
Maximum Allowable Pressure (psig)	PMA	150	
Maximum Allowable Temperature (°F)	TMA	428	
Motive Medium Pressure Range (psig)		5 - 75	
Maximum Allowable Back Pressure		7 psi less than motive medium pressure used	
Volume of Each Discharge Cycle (gal)		Approximately 3/8	
Motive Medium*		Saturated Steam, Compressed Air, Nitrogen	
Pumped Medium**		Steam Condensate, Water	

* Do not use with toxic, flammable or otherwise hazardous fluids.

Connections and sizes in bold are standard

** Do not use for fluids with specific gravities under 0.85 or over 1, or for toxic, flammable or otherwise hazardous fluids.



To avoid abnormal operation, accidents or serious injury, DO NOT use this product outside of the specification range. Local regulations may restrict the use of this product to below the conditions quoted.

No.	Description	Material	ASTM/AISI*	JIS
①	Body	Cast Iron	A126 Cl.B	FC250
		Cast Stainless Steel	A351 Gr.CF8M	—
②	Cover	Cast Iron	A126 Cl.B	FC250
		Cast Stainless Steel	A351 Gr.CF8M	—
③ ^M	Cover Gasket	Fluorine Resin	PTFE	PTFE
④ ^F	Float	Stainless Steel	AISI316L	SUS316L
⑤ ^{R3}	Snap-action Unit	Stainless Steel	—	—
⑥ ^{R6}	Snap-action Spring**	Stainless Steel	—	—
⑦ ^{R1}	Intake-Exhaust Valve Unit	Stainless Steel	AISI440C	SUS440C
		Stainless Steel	AISI440C	SUS440C
⑧ ^{R4}	Outlet Check Valve Unit	Stainless Steel	AISI304	SUS304
⑨ ^{R2}	Exhaust Plug	Stainless Steel	—	—
⑩ ^{R5}	Inlet Check Valve Unit	Stainless Steel	AISI304	SUS304
⑪ ^M	Seal Set	—	—	—

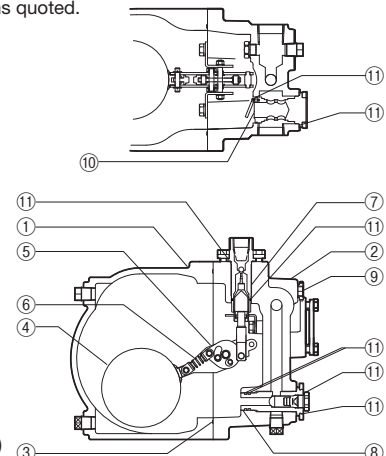

* Equivalent ** Also included in R3 (Snap-action Unit repair kit)
 Replacement kits available: (M) maintenance parts, (R1-R6) repair kits, (F) Float
 When ordering a repair kit or other parts, it is recommended to order additional maintenance parts (M) as replacement gaskets may be required

Dimensions

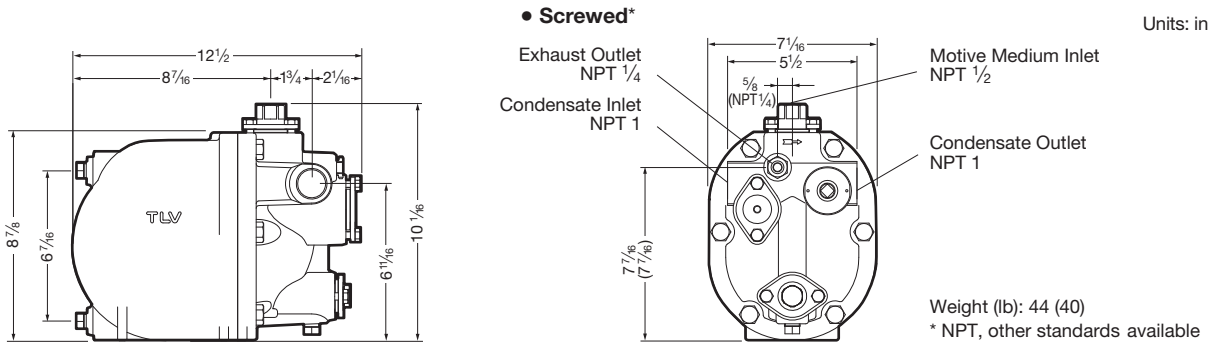

Note: All Plug Holes are NPT 3/8
() is for Stainless Steel

Discharge Capacity

Filling Head: 6" from Grade

Inlet Pipe Size		1"	
Inlet Check Valve		Built-in	
Outlet Check Valve		Built-in	
Motive Medium		Air	Steam
Motive Medium Inlet Pressure (P _m) (psig)	Total Lift or Back Press. (P ₂) (psig)	lb/h	lb/h
75	5	390	320
	15	350	280
	25	300	230
	35	260	190
	50	200	140
	65	140	80
65	68	120	70
	5	370	310
	15	330	270
	25	280	220
	35	230	180
	50	170	120
50	58	130	80
	5	350	300
	15	300	250
	25	240	200
	35	190	130
35	43	150	100
	5	320	270
	15	250	200
	25	180	140
25	28	170	120
	5	290	240
	10	240	210
15	18	190	150
	5	250	200
	8	210	160

• **Correction Factor**
For GP5C installed with filling head other than 6" (minimum)

Filling Head from Grade	Correction Factor
40"	2.82
30"	2.60
20"	2.33
16"	2.13
12"	1.94
8"	1.50
6"	1.00

Illustration of Filling Head and Pressures

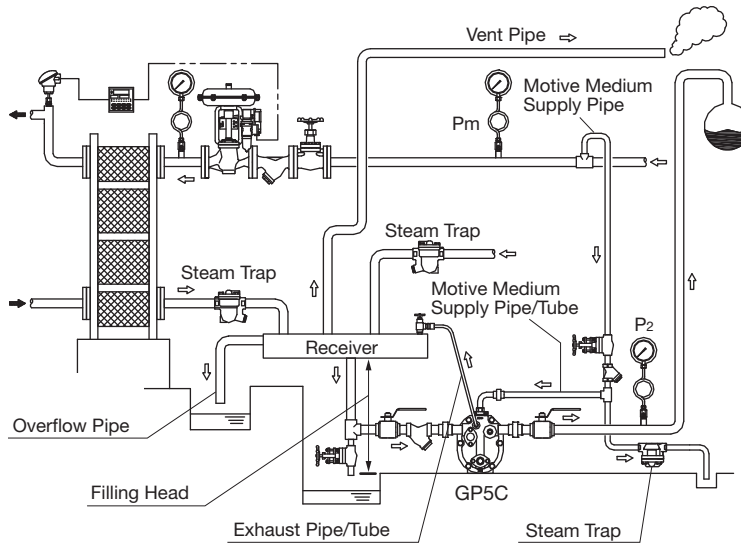

The discharge capacity is determined by the motive medium, motive medium pressure (P_m) and back pressure (P₂).

Make sure that:
 Discharge Capacity × Correction Factor
 > Required Flow Rate

For explanation purposes only, not intended as an installation design.

NOTE:

- GP5C should be used in an open system in which the receiver is open to the atmosphere.
- Motive medium pressure minus back pressure must be greater than 7 psi.
- The motive medium supply pipe diameter should be at least 1", and the motive medium supply pipe/tube and its fittings/valves should have an inner diameter of at least 1/4".
- A 40 mesh or finer strainer must be installed at the motive medium and pumped medium inlets.

Receiver Sizing Table

The receiver must have a capacity sufficient to store the condensate produced during the PowerTrap operation and discharge. A receiver that must handle the condensate both as a liquid and as flash steam will generally be larger than a receiver that handles condensate only as a liquid, and should separate one from the other so that only condensate is sent to the PowerTrap. When supercooled condensate is pumped, there may be cases in which hardly any flash steam is produced.

1. Size of Receiver; flash steam is involved

(Length: 3.5 ft)

Flash steam up to (lb/h)	Receiver diameter (in)	Vent pipe diameter (in)	Overflow pipe diameter
50	3	1	Overflow pipe diameter should be equal to or greater than the condensate inlet pipe diameter.
75	4	1½	
100	4	2	Diameter for receiver must be equal to or more than 3× the overflow pipe diameter.
200	6	2½	

2. Size of Receiver; flash steam is not involved

(Length: 3.5 ft)

Amount of condensate (lb/h)	Receiver diameter (in)
75 or less	1
200	1½
400	1½
600	2
800	2½
1000	3

- Reservoir length can be reduced by 50% when the motive medium pressure (P_m) divided by back pressure (P₂) equals 2 or greater (when P_m ÷ P₂ ≥ 2).

Memo:



DO NOT DISASSEMBLE OR REMOVE THIS PRODUCT WHILE IT IS UNDER PRESSURE.
 Allow internal pressure of this product to equal atmospheric pressure and its surface to cool to room temperature before disassembling or removing. Failure to do so could cause burns or other injury. READ INSTRUCTION MANUAL CAREFULLY.

TLV CORPORATION

13901 South Lakes Drive, Charlotte, NC 28273-6790
 Tel: 704-597-9070 Fax: 704-583-1610
 E-mail: tlv@tlvengineering.com <https://www.tlv.com>
 For Technical Service 1-800 "TLV TRAP"



Manufacturer
TLV CO., LTD.
 Kakogawa, Japan
 is approved by LRQA Ltd. to ISO 9001/14001

