

Venue Mobile

by *Claridge*

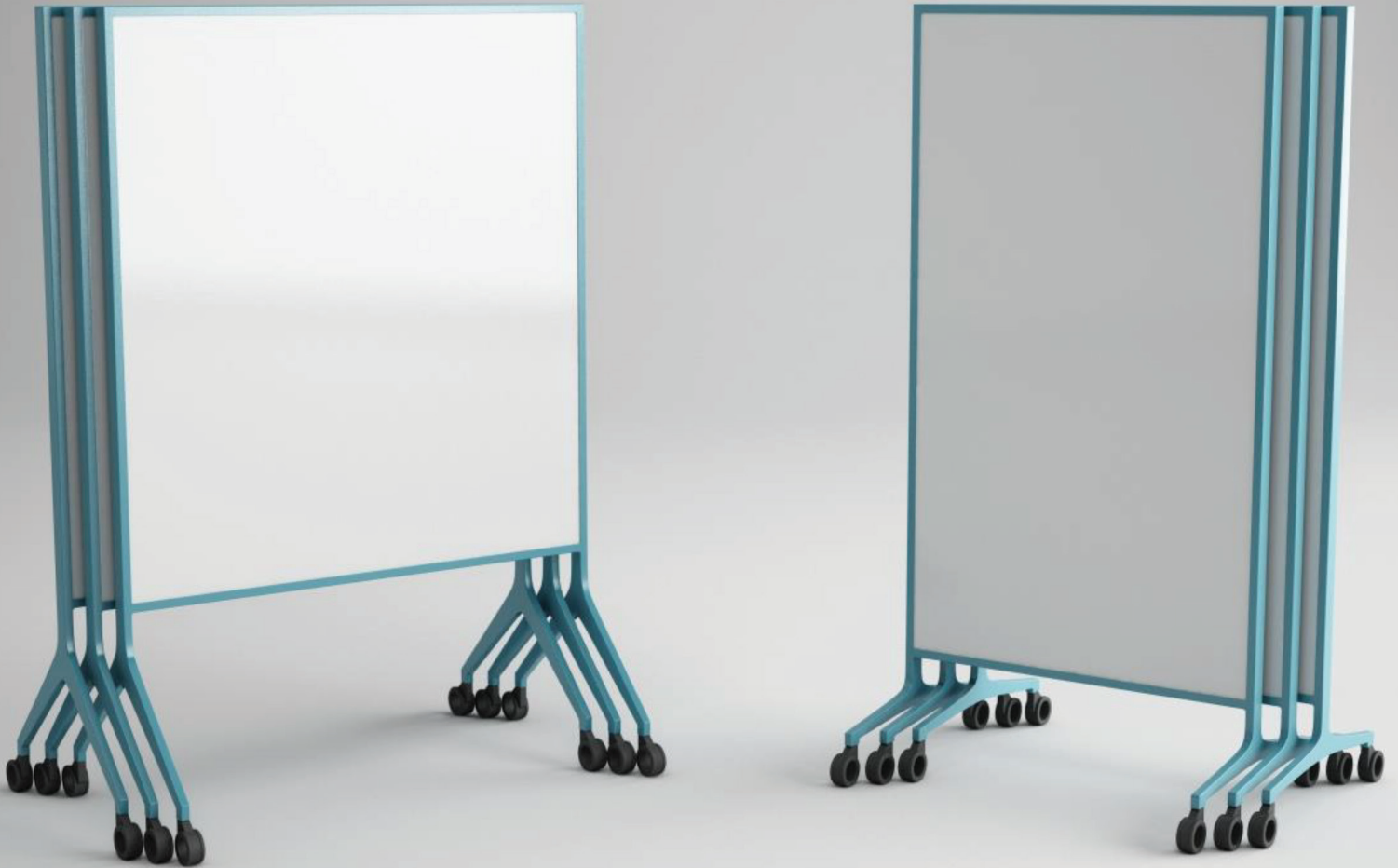

Venue Mobiles enhance a variety of aesthetics with a vast library of color finishes, writing surfaces, and textiles to blend in with any aesthetic. It is Venue's timeless design that allows this adaptive visual communications mobile to work with an existing conference room, collaboration space, or a new system within the open plan.

Venue Mobile

PRODUCT DESIGN NOTES

- **V-Leg Mobile:** upright design with board surface starting approximately 18" from the floor, slightly more approachable.
- **T-Leg Mobile:** lower profile design with board surface starting approximately 10" from the floor, convenient nesting - available in full or split panels.
- Comes with two (2) locking and two (2) non-locking Hubless Casters. The hollow interior not only projects a unique aesthetic appeal but even enhances the overall stability.

PRODUCT FEATURES

Writing Surfaces:

Claridge Porcelain - 6 standard Porcelain colors
Claridge Glass - 10 standard Glass colors

Fabrics & Textiles:

Claridge Acoustics - 5 standard plus 15 optional colors
Carnegie, Marharam, or Guilford materials available. Call for pricing.

Standard Colors:

Frame and Legs:

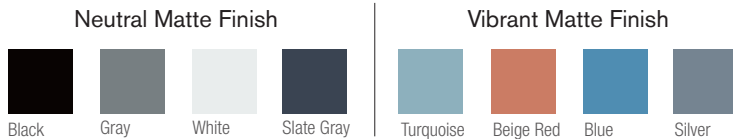

Standard Sizes:

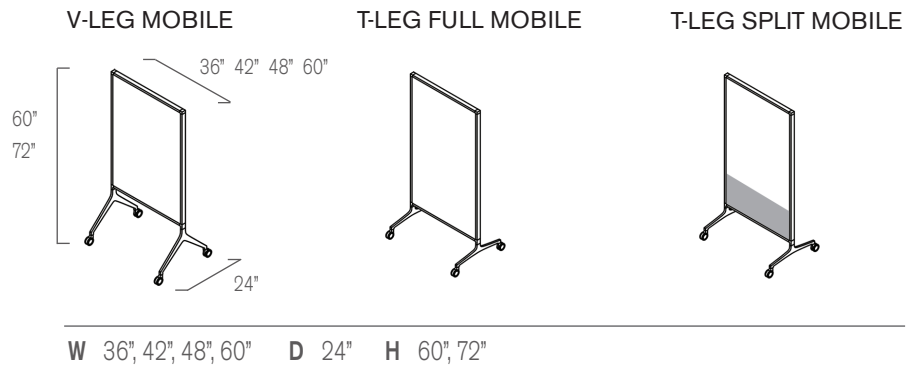

Optional Accessories: Magnetic Marker Tray, Claridge Acoustic Tack Pads