



# FLOATDYNAMIC STEAM TRAP

## MODEL JH15

### CAST STEEL FLOAT-PISTON TRAP FOR HIGH CAPACITY PROCESS APPLICATION

#### Benefits

**High pressure, cast steel, inline maintainable, float dynamic steam trap capable of discharging condensate at high flow rates. Suitable for large process heat exchangers.**

1. Self-modulating free float pilot mechanism ensures discharge at near-to-steam temperatures.
2. Proven piston valve allows "pulsing" discharge of condensate at high flow rates and intermittent discharge at low flow rates.
3. Steam chamber design prevents damage to the valve and valve seat on closure.
4. All internal parts are accessible without having to remove the trap from the line.
5. Two built-in screens with large surface area ensure trouble-free operation.
6. Rugged float construction with up to 2300 psig hydraulic shock rating ensures excellent resistance to water hammer.

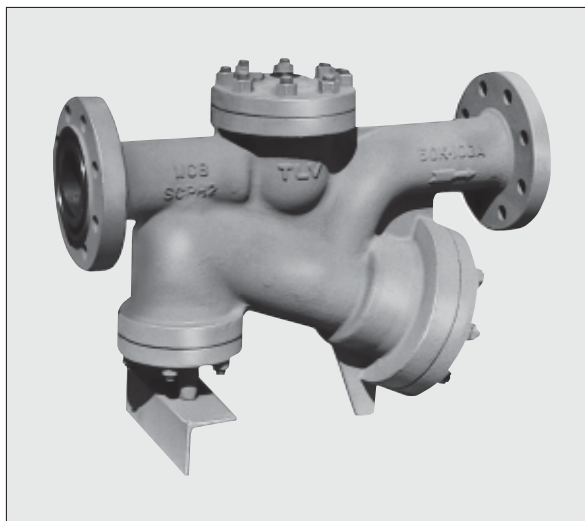

#### Specifications

Model	JH15E-21, JH15M-21, JH15S-21	JH15E-46, JH15M-46, JH15S-46
Connection	Flanged	
Size (in)	4	
Max. Operating Pressure (psig) PMO	300	650
Max. Differential Pressure (psi) ΔPMX	300	650
Min. Differential Pressure (psi)	7	
Max. Operating Temperature (°F) TMO	800	
Max. Allowable Pressure (psig) PMA	710	
Max. Allowable Temperature (°F) TMA	800	

JH15 is a non-standard product, consult TLV for delivery time required.



To avoid abnormal operation, accidents or serious injury, do not use this product outside of the specification range. Local regulations may restrict the use of this product to below the conditions quoted.

No.	Description	Material	ASTM/AISI*	JIS
①	Body	Cast Steel	A216 Gr.WCB	—
②	Cover	Carbon Steel	AISI1025	S25C
③	Float	Stainless Steel	AISI316L	SUS316L
④	Float Screen	Stainless Steel	AISI430	SUS430
⑤	Float Cover	Stainless Steel	AISI304	SUS304
⑥	Cover Gasket	Graphite/Stainless Steel	-/AISI304	-/SUS304
⑦	Cover Bolt	Alloy Steel	A193 Gr.B16	SNB16
⑧	Cover Nut	Carbon Steel	AISI1045	S45C
⑨	Main Valve Screen, inside/outside	Stainless Steel	AISI304/430	SUS304/430
⑩	Screen Cover	Cast Steel	A216 Gr.WCB	—
⑪	Screen Cover Gasket	Graphite/Stainless Steel	-/AISI304	-/SUS304
⑫	Screen Cover Bolt	Alloy Steel	A193 Gr.B7	SNB7
⑬	Screen Cover Nut	Carbon Steel	AISI1045	S45C
⑭	Valve Cover	Cast Steel	A216 Gr.WCB	—
⑮	Valve Cover Gasket	Graphite/Stainless Steel	-/AISI304	-/SUS304
⑯	Valve Cover Bolt	Alloy Steel	A193 Gr.B7	SNB7
⑰	Valve Cover Nut	Carbon Steel	AISI1045	S45C
⑱	Orifice	—	—	—
⑲	Orifice Gasket	Soft Iron	AISI1010	SUYF
⑳	Connector Pipe	Stainless Steel	AISI304	SUS304
㉑	Main Valve	—	—	—
㉒	Valve Seat	—	—	—
㉓	Cylinder	—	—	—
㉔	Piston Ring Set**	Carbon/Stainless Steel	-/AISI304	-/SUS304
㉕	Piston	Stainless Steel	AISI303	SUS303
㉖	Small Valve Seat Gasket	Graphite/Stainless Steel	-/AISI304	-/SUS304
㉗	Large Valve Seat Gasket	Graphite/Stainless Steel	-/AISI304	-/SUS304
㉘	Sleeve	Stainless Steel	AISI420F	SUS420F
㉙	Plug	Carbon Steel	AISI1025	S25C
㉚	Plug Gasket	Soft Iron	AISI1010	SUYF

\* Equivalent \*\* 1 on JH15-21, 3 on JH15-46

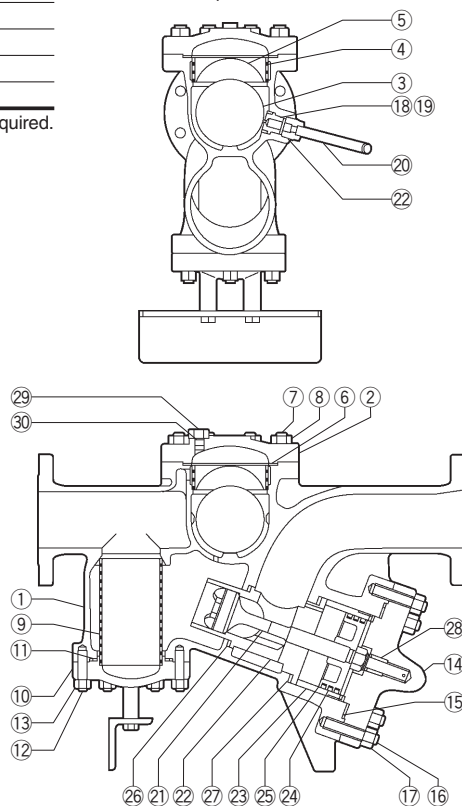

Copyright © TLV

**Dimensions**

● **JH15** Flanged

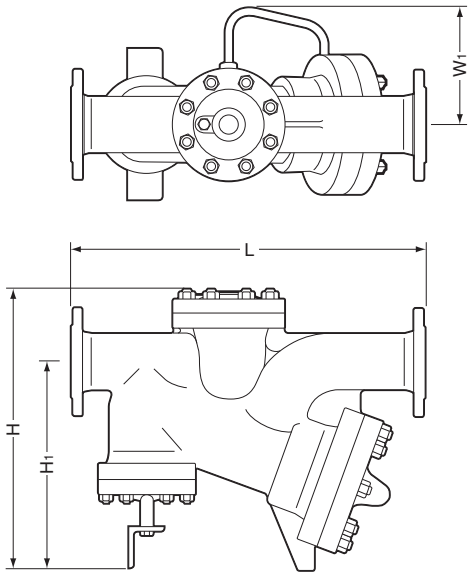

**JH15** Flanged (in)

Model	Size	L			H	H <sub>1</sub>	W <sub>1</sub>	Weight* (lb)
		Connects to ASME Class						
		150RF	300RF	600RF				
JH15-21	4	29½	30¾	—	237/16	175/16	913/16	388 (410)
JH15-46		—		319/16				

Other standards available, but length and weight may vary  
 \* Weight is for Class 300 RF (600 RF)

**Note: Piping Arrangement**

- The horizontal piping sections should be sized according to the condensate load and velocity, without sharp bends, and using eccentric reducers for pipe size adjustment.
- A check valve must be installed on the outlet side.
- Install air bleed line and valve, and discharge safely to grade.
- Consult with TLV in case of difficulties with piping arrangement

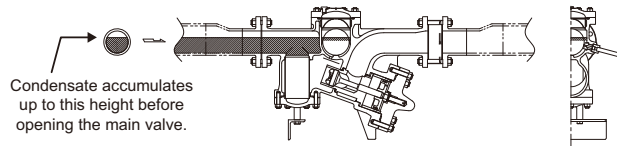

Inlet horizontal piping		Outlet piping**
Length (ft)	Size (in)	
4*	12*	Size the horizontal and vertical piping sections according to the condensate load and velocity. Use the TLV Engineering Calculator or ToolBox app, "Condensate Recovery Pipe Sizing for Condensate Recovery Line by Velocity" function.  Recommended fluid velocities: • Flash steam: approx. 98 to 115 ft/s • Condensate component: ≤ 6.5 ft/s
4.5	10	
5	8	
8	6	
11	5	
16	4	

\* Recommended by TLV \*\* Schedule 160 piping recommended

**Discharge Capacity**

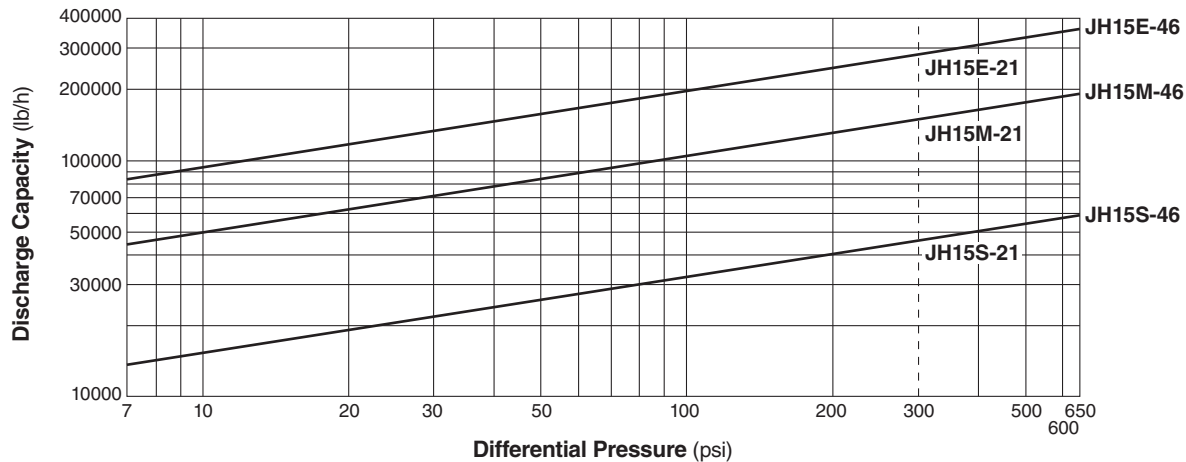

1. Differential pressure is the difference between the inlet and outlet pressure of the trap.
2. Capacities are based on continuous discharge of condensate 11 °F below saturated steam temperature.
3. Select the closest model with a capacity greater than the actual condensate load multiplied by a safety factor of 1.2.

**CAUTION** DO NOT use this product under conditions that exceed maximum differential pressure, as condensate backup will occur!

**CAUTION** DO NOT DISASSEMBLE OR REMOVE THIS PRODUCT WHILE IT IS UNDER PRESSURE. Allow internal pressure of this product to equal atmospheric pressure and its surface to cool to room temperature before disassembling or removing. Failure to do so could cause burns or other injury. READ INSTRUCTION MANUAL CAREFULLY.

**TLV CORPORATION**

13901 South Lakes Drive, Charlotte, NC 28273-6790  
 Tel: 704-597-9070 Fax: 704-583-1610  
 E-mail: [tlv@tlvengineering.com](mailto:tlv@tlvengineering.com) <https://www.tlv.com>  
 For Technical Service 1-800 "TLV TRAP"



Manufacturer  
**TLV CO., LTD.**  
 Kakogawa, Japan  
 is approved by LRQA Ltd. to ISO 9001/14001

