



MULTI-CONTROLLER

MODEL SC-F71

COMPACT MULTI-PURPOSE CONTROLLER WITH MC-COS CONTROL FEATURE

Benefits

Compact multi-purpose controller for a wide range of operations. Ideal for equipment automation and systems creation in many fields.

Allows pressure or temperature control when combined with automatic control valve [MC-COS (R)]. Allows PID control with auto-tuning when combined with pneumatic control valves.

1. High measurement accuracy of 0.1% F.S.
2. Quick and easy to determine PID setting using auto-tune function for excellent stability and responsiveness. Overshoot prevention function.
3. 16 target settings can be stored in memory.
4. 5 digit × 3 row panel clearly displays a variety of information.
5. Up to 4 contacts for event output, up to 3 contacts for transmission output and up to 6 contacts for external input.
6. Measurement input area can accommodate various input signals.
7. Voltage: 100 V – 240 V AC.
8. Conforms with CE marking.
9. Loader communication connection available on front panel. Requires optional USB adapter.



Dimensions

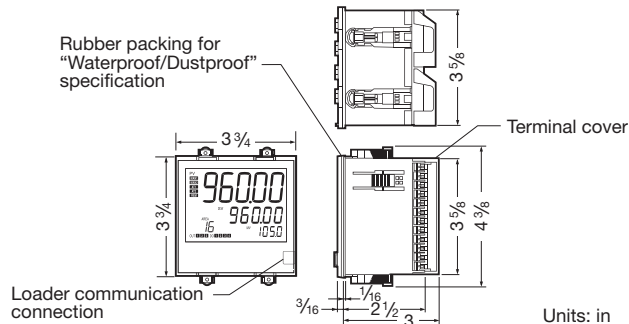

Panel Cutout and Spacing

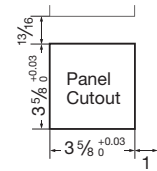

Panel thickness: 1/16 to 3/8 in

Wiring Terminals

No.	Function	No.	Function	No.	Function
1	AC L 100-240V N	25	—+ Voltage Pulse/Current	13	NO Relay Contact Digital Output 2 (DO 2)
2	Power Terminals	26	—- Voltage Pulse/Current	14	NO Relay Contact Digital Output 2 (DO 2)
3	—+ Output 2 (OUT2)	27	(Voltage Free Contact Input)	15	NO Relay Contact Digital Output 3 (DO 3)
4	—- Current Output	28	COM DI 1	16	NO Relay Contact Digital Output 3 (DO 3)
5	—+ Output 1 (OUT1)	29	— DI 2	17	NO Relay Contact Digital Output 4 (DO 4)
6	—- Current Output	30	— DI 3	18	NO Relay Contact Digital Output 4 (DO 4)
7		31	— DI 4	19	
8	NO Relay Contact	32	— DI 5	20	
9	Contact Digital Output 1 (DO 1)	33	— DI 6	21	
10	A Measurement Input 1	34	— SG Communication RS-422A	22	A Remote Setting Input Measurement
11	B + (1) Thermocouple (2) RTD	35	— T(A)	23	B + (1) Thermocouple
12	(1) - (2) - (3) Voltage/Current	36	— T(B)	24	(2) RTD (3) Voltage/Current

Specifications

Item		Description			
Measurement Input	Measurement Input Types	Thermocouple (TC)	RTD	Voltage	Current
	Effects of Signal Resistance	approx. 0.18 $\mu\text{V}/\Omega$	—	—	—
	Input Line Resistance	—	approx. 0.006%/ Ω of span	—	—
	Input Impedance	1M Ω minimum	—	1M Ω minimum	approx. 50 Ω
	Measurement Accuracy	See "Measurement Accuracy" for details \pm (0.1% F.S. + 1 digit)			
	Number of inputs	2 inputs (Input 2 can be configured for used with 2-loop control or remote setting input)			
	Sampling Period	0.05 second for 1-loop control, 0.1 second for 2-loop control			
Displays	Set Values Display	5 digit 11 segment LED + 5 digit 7 segment LED \times 2 lines			
	Area Display	2 digit 7 segment LED			
Settings	Operation Display	MAN1, MAN2, AT1, AT2, REM, OUT1, OUT2, OUT3, D01, D02, D03, D04, ALM			
	Number of Memory Settings	16 memory items			
Control	Memory Functions	Target setting, soft start time, event set value (and more)			
	Control Operation Types	<ul style="list-style-type: none"> • PID control with auto-tuning (reverse / direct) • Heating/cooling PID control • Pressure control [MC-COS(R) / MC-VCOS(R)] • Temperature control [MC-COS(R) / MC-VCOS(R)] 			
Output	Control Output	No. of Contacts	1 or 2 contacts (for heating/cooling PID control or 2-loop control)		
		Output Signal	Current output: 4 to 20 mA or 0 to 20 mA, load resistance: 500 Ω maximum		
	Transmission Output	No. of Contacts	2 or 1 contacts (for heating/cooling PID control or 2-loop control)		
		Output Types	Measured values (PV), set values, deviation values, heating control output values, cooling control output values (for heating/cooling PID control only)		
	Event Output	Output Signal	Current output: 4 to 20 mA or 0 to 20 mA, load resistance: 500 Ω maximum		
		No. of Contacts	4 contacts		
External Input	Analog Setting Input	Output Types	Measurement upper limit, measurement lower limit, deviation upper limit, deviation lower limit		
		Output Signal	1a contact (contact rating (resistive load): 250 V AC (1 A) / 30 V DC (0.5 A))		
	Contact Input	No. of Contacts	1 contact or none (for heating/cooling PID control or two-loop control)		
Communication	Host Communication	Function	Input target setting via external analog signal		
		No. of Contacts	6 or 4 contacts (when communication function selected)		
	Loader Communication	Function	RUN/STOP, AUTO/MAN, REM/LOC selection, memory area selection		
		Interface	Based on RS-422A, EIA standard		
		Protocol	Original communication: ANSI X3.28-1976 subcategory 2.5 A4 compliant MODBUS communication: MODBUS-RTU PLC communication*: MAPMAN communication (* Optional USB adapter and PROTEM-T software required)		
		Comm. Speed	2400, 4800, 9600, 19200, 38400, 57600 bps		
		Protocol	Original communication: ANSI X3.28-1976 subcategory 2.5 A4 compliant		
Comm. Speed	38400 bps				
Connectable Devices	1 device				
Connection Method	Optional USB adapter: RKC Instrument Inc. COM-K2 cable (from front panel connector)				
General Specs.	Ambient Temperature Range	14 to 131 $^{\circ}\text{F}$			
	Ambient Humidity Range	5 – 95% RH (non-condensing)			
	Voltage	Rating 100 – 240 V AC (50/60 Hz)			
	Power Consumption	7.4 VA maximum (at 100 V AC), 10.9 VA maximum (at 240 V AC)			
	Effect of Power Outage	No effect for power outage of 20 ms or less (5 ms for current input)			
	Memory Backup	Backed up by non-volatile memory, data storage period approx. 10 years (depending on storage time and environment and operating conditions, etc.)			
	Weight	approx. 11 oz			
Protection Class	IP65 (optional; applicable when front panel cover and loader connector covers are attached)				
Accessories	Terminal covers (2 covers per controller); Rubber packing for "Waterproof/Dustproof" specifications (pre-fitted)				

Measurement Accuracy

Input Types	Input Range	Accuracy
K, J, T, E, U, L ¹⁾	< -148 $^{\circ}\text{F}$	\pm (1.8 $^{\circ}\text{F}$ + 1 digit)
	-148 $^{\circ}\text{F}$ to < + 932 $^{\circ}\text{F}$	\pm (0.9 $^{\circ}\text{F}$ + 1 digit)
	\geq 932 $^{\circ}\text{F}$	\pm (0.1% of reading + 1 digit)
N, R, S, PIII, W5Re/W26Re ²⁾	< 32 $^{\circ}\text{F}$	\pm (3.6 $^{\circ}\text{F}$ + 1 digit)
	32 $^{\circ}\text{F}$ to < 1832 $^{\circ}\text{F}$	\pm (1.8 $^{\circ}\text{F}$ + 1 digit)
	\geq 1832 $^{\circ}\text{F}$	\pm (0.1% of reading + 1 digit)
B ²⁾	< 752 $^{\circ}\text{F}$	\pm (126 $^{\circ}\text{F}$ + 1 digit)
	752 $^{\circ}\text{F}$ to < 1832 $^{\circ}\text{F}$	\pm (2.52 $^{\circ}\text{F}$ + 1 digit)
	\geq 1832 $^{\circ}\text{F}$	\pm (0.1% of reading + 1 digit)
PR40-20 ²⁾	< 752 $^{\circ}\text{F}$	\pm (36 $^{\circ}\text{F}$ + 1 digit)
	752 $^{\circ}\text{F}$ to < 1832 $^{\circ}\text{F}$	\pm (18 $^{\circ}\text{F}$ + 1 digit)
	\geq 1832 $^{\circ}\text{F}$	\pm (0.1% of reading + 1 digit)
Pt100, JPt100	< 392 $^{\circ}\text{F}$	\pm (0.36 $^{\circ}\text{F}$ + 1 digit)
	\geq 392 $^{\circ}\text{F}$	\pm (0.1% of reading + 1 digit)
	0.00 to 90.00 $^{\circ}\text{F}$	\pm (0.18 $^{\circ}\text{F}$ + 1 digit)
Voltage/Current input	\pm (0.1% of span + 1 digit)	

¹⁾ Accuracy is not guaranteed for less than -148 $^{\circ}\text{F}$

²⁾ Accuracy is not guaranteed for less than 752.0 $^{\circ}\text{F}$ for Input type R, S, B, PR40-20 and W5Re/W26ERe

Measurement Input Types & Ranges

Input Types	Input Range	Code		
Thermocouple (TC)	0 – 200 °C	K01		
	0 – 400 °C	K02		
	0 – 600 °C	K03		
	Type K (EX: CA) [JIS/IEC]	0 – 800 °C	K04	
		0 – 1200 °C	K06	
		0 – 1372 °C	K07	
		-199.9 – +300.0 °C	K08	
		0.0 – 400.0 °C	K09	
		0.0 – 800.0 °C	K10	
		0 – 300 °C	K14	
		-200 – +1372 °C	K41	
		-200.0 – +1372.0 °C	K42	
		0 – 800 °F	KA1	
		0 – 1600 °F	KA2	
		0 – 2502 °F	KA3	
		Type J (EX: IC) [JIS/IEC]	0 – 200 °C	J01
			0 – 400 °C	J02
			0 – 600 °C	J03
	0 – 800 °C		J04	
	0.0 – 400.0 °C		J08	
	-200.0 – +1200.0 °C		J29	
	0 – 800 °F		JA1	
	0 – 2192 °F		JA3	
	0 – 400 °F		JA6	
	Type T (EX: CC) [JIS/IEC]		-199.9 – +400.0 °C	T01
			-199.9 – +100.0 °C	T02
			-100.0 – +200.0 °C	T03
			-200.0 – +400.0 °C	T19
	Type S [JIS/IEC]		-50 – +1768 °C	S06
	Type R [JIS/IEC]		0 – 1600 °C	R01
			-50 – +1768 °C	R07
	Type E (EX: CRC) [JIS/IEC]		0 – 800 °C	E01
	Type B [JIS/IEC]		0 – 1800 °C	B03
Type N [JIS/IEC]	0 – 1300 °C	N02		
Type PLII [NBS]	0 – 1300 °C	A01		
Type W5Re/W26Re [ASTM]	0 – 2300 °C	W03		
Type PR40-20 [ASTM]	0 – 1800 °C	F02		
	0 – 3200 °F	FA2		
Type U [DIN]	-199.9 – +600.0 °C	U01		
Type L [DIN]	0 – 900.0 °C	L04		
RTD	Type Pt100 [JIS/IEC]	-199.9 – +649.0 °C	D01	
		-100.0 – +100.0 °C	D04	
		-100.0 – +200.0 °C	D05	
		0.0 – 50.0 °C	D06	
		0.0 – 100.0 °C	D07	
		0.0 – 200.0 °C	D08	
		0.0 – 300.0 °C	D09	
		0.0 – 500.0 °C	D10	
		-199.9 – +600.0 °C	D12	
		-200.0 – +200.0 °C	D21	
		0.00 – 50.00 °C	D27	
		-100.00 – +100.00 °C	D34	
		-200.0 – +850.0 °C	D35	
		-199.9 – +999.9 °F	DA1	
		0.0 – 500.0 °F	DA9	
	Type JPt100 [JIS]	0.0 – 200.0 °C	P08	
		-100.00 – +100.00 °C	P29	
		-200.0 – +640.0 °C	P30	
	Voltage/Current	Programmable range -19999 to +99999	0 – 10 mV DC	101
			0 – 100 mV DC	201
			0 – 1 V DC	301
			0 – 5 V DC	401
			0 – 10 V DC	501
			1 – 5 V DC	601
0 – 20 mA DC			701	
4 – 20 mA DC			801	
-10 – +10 V DC			904	
-5 – +5 V DC			905	

Pressure Unit & Range Codes

Applicable Valve	Unit	Pressure Sensor Model	Range	Code	
MC-COS	°C / kg/cm ² G	MBS33M	0 – 5.10	001	
			0 – 10.20	002	
			0 – 20.40	003	
		0 – 25.50	004		
		KH15	0 – 5.00	005	
			0 – 10.00	006	
	0 – 20.00		007		
	°C / barg	MBS33M	0 – 5.00	101	
			0 – 10.00	102	
		KH15	0 – 20.00	103	
			0 – 25.00	104	
	MC-COSR	°F / psig	MBS33M	0 – 5.00	105
				0 – 10.00	106
				0 – 20.00	107
KH15			0 – 72.5	201	
			0 – 145.0	202	
			0 – 290.1	203	
°C / kPaG		MBS33M	0 – 362.6	204	
			0 – 75.0	205	
			0 – 150.0	206	
			0 – 300.0	207	
			0 – 500	301	
°C / MPaG		MBS33M	0 – 1000	302	
			0 – 2000	303	
			0 – 2500	304	
	0 – 0.500		401		
	0 – 1.000		402		
	0 – 2.000		403		
	0 – 2.500		404		
	MC-VCOS		°C / mmHgG	MBS33M	-760 – +2240
		KH15	-736 – +736	A02	
°C / mmHg abs		MBS33M	0 – 3000	A13	
		KH15	24 – 1496	A14	
°C / mbarg		MBS33M	-1013 – +2987	B01	
		KH15	-981 – +981	B02	
°C / mbar abs		MBS33M	0 – 4000	B13	
		KH15	33 – 1994	B14	
°C / inHgG		MBS33M	-29.9 – +88.2	C01	
MC-VCOSR		°C / inHg abs	MBS33M	0 – 118.1	C12
		°F / psig	MBS33M	-14.70 – +43.32	D01
			KH15	-14.22 – +14.22	D02
		°F / psi abs	MBS33M	0 – 58.02	D13
			KH15	0.48 – 28.92	D14
	°C / kPaG	MBS33M	-101.3 – +298.7	E01	
	°C / kPa abs	MBS33M	0 – 400.0	E12	

Temperature Unit Codes

Applicable Valve	Unit	Code
MC-COS	°C / kg/cm ²	001
	°C / bar	101
	°F / psi	201
MC-COSR	°C / kPa	301
	°C / MPa	401
	°C / mmHg	A01
MC-VCOS	°C / mbar	B01
	°C / inHg	C01
MC-VCOSR	°F / psi	D01
	°C / kPa	E01

Specifications Checksheet

		Code			Remarks	
Model	SC-F71		<input type="text"/>	<input type="text"/>	For boxes in the "code" section to the left, enter the appropriate code from among the specification items below each box.	
Basic Specifications	Control Operation Type	<ul style="list-style-type: none"> • PID control with auto-tuning (Reverse) • PID control with auto-tuning (Direct) • Heating/cooling PID control • Pressure control operation [MC-COS (R)-3] • Pressure control operation [MC-COS (R)-16, 1/2" - 2"] • Pressure control operation [MC-COS (R)-16, 2 1/2" - 6"] • Pressure control operation [MC-COS (R)-21] • Pressure control operation [MC-VCOS (R)] • Temperature control operation [MC-COS (R)-16] • Temperature control operation [MC-VCOS (R)] 	F D G 2 3 4 5 6 7 8			
	Communications Function	<ul style="list-style-type: none"> • None • RS-422A (4-wire type) 	N 4		Select to match the computer to be connected	
Additional Specs.	Waterproof/Dustproof	<ul style="list-style-type: none"> • Waterproof/dustproof (IP65) 		1		
Initial Settings*	Measurement Input Types & Ranges (PV)	<ul style="list-style-type: none"> • Thermocouple (TC) • RTD • Voltage input • Current input 			Range code <input type="text"/>	Select the type and range code from "Measurement Input Types & Ranges". Values can be changed after the controller has been shipped by changing parameters.
	Pressure/Temperature Sensor Range	Pressure control operation Temperature control operation			Range code <input type="text"/>	Specify the range of the pressure sensor to be connected. Specify the units to be used.

* Initial settings can be changed after the controller has been shipped from the factory. When not specified in advance, items are set to their default values before shipment.

Options

Front panel cover	Clear resin, snap-on type
Sensor power source	OMRON Corporation S8VS-01524, 24 V DC
USB communication adapter	RKC Instrument Inc. COM-K2-4, 5 ft (with RKC W-BV-05-1500)

Data Management Tool PROTEM-T

Functions	Verify and set SC-F71 set values Log trend data Create complete set value lists Back-up set values
Operating System	Windows 7/8/8.1/10 (32-bit/64-bit)

For details and to download, see TLV website. Optional USB adapter required for communication with SC-F71.

All company names, product names, trademarks and registered trademarks are property of their respective owners.

TLV CORPORATION

13901 South Lakes Drive, Charlotte, NC 28273-6790

Tel: 704-597-9070 Fax: 704-583-1610

E-mail: tlv@tlvengineering.com <https://www.tlv.com>

For Technical Service 1-800 "TLV TRAP"



Manufacturer
TLV CO., LTD.
 Kakogawa, Japan
 is approved by LRQA Ltd. to ISO 9001/14001

ISO 9001
 ISO 14001

