



PowerTrap®

MODEL GT10M

COMBINATION PUMPING AND TRAPPING SECONDARY PRESSURE DRAINER

Benefits

Pump/Trap with built-in steam trap for a wide range of applications: drainage of low capacity heat exchangers, flash steam recovery systems and reservoirs, often operating under vacuum conditions.

1. No cavitation or seal leakage.
2. Non-electric design with durable nickel-based alloy compression spring for reliable performance.
3. Pump will operate with a low filling head (min. 12").
4. Easy, inline access to internal parts simplifies cleaning and reduces maintenance costs.
5. Intake/exhaust valve heads are both Rockwell 65C with 45C seats for maximum durability.
6. High quality stainless steel internals ensure reliability.
7. Compact design permits installation in a limited space.
8. Float resists hydraulic shock to 1500 psig.
9. 2-year warranty for snap-action mechanism.*

* Contact TLV for details



Specifications

Model		GT10M
Connection	Pumped Medium Inlet & Outlet	Flanged*
	Motive Medium & Pump Exhaust	Screwed
Size (in)	Pumped Medium: Inlet x Outlet	1½ x 1"
	Motive Medium Inlet	½
	Pump Exhaust Outlet	½
Maximum Operating Pressure (psig)	PMO	150
Maximum Operating Temperature (°F)	TMO	365
Maximum Allowable Pressure (psig)	PMA	Cast Iron: 230 Cast Steel: 300
Maximum Allowable Temperature (°F)	TMA	428
Motive Medium Pressure Range (psig)		5 – 150
Maximum Allowable Back Pressure		7 psi less than motive medium pressure used
Volume of Each Discharge Cycle (gal)		approximately 2
Motive Medium**		Saturated Steam
Pumped Medium***		Steam Condensate

* For details of flange connection, see picture at bottom right

** Do not use with toxic, flammable or otherwise hazardous fluids.

*** Do not use for fluids with specific gravities under 0.85 or over 1, or for toxic, flammable or otherwise hazardous fluids.

Connections and sizes in bold are standard



To avoid abnormal operation, accidents or serious injury, DO NOT use this product outside of the specification range. Local regulations may restrict the use of this product to below the conditions quoted.

No.	Description	Material	ASTM/AISI*	JIS	
①	Body	Cast Iron	A126 Cl.B	FC250	
		Cast Steel**	A216 Gr.WCB	—	
②	Cover	Cast Iron	A126 Cl.B	FC250	
		Cast Steel**	A216 Gr.WCB	—	
③	Cover Gasket	Graphite Compound	—	—	
④	Float	Stainless Steel	AISI316L	SUS316L	
⑤	Snap-action Unit	Stainless Steel	—	—	
⑥	Motive Medium Intake Valve Unit	Intake Valve	Stainless Steel	AISI440C	SUS440C
		Valve Seat	Stainless Steel	AISI420F	SUS420F
⑦	Exhaust Valve Unit	Exhaust Valve	Stainless Steel	AISI440C	SUS440C
		Valve Seat	Stainless Steel	AISI420F	SUS420F
⑧	Trap Unit	Stainless Steel	—	—	
⑨	Inlet Check Valve CKF5M	Stainless Steel	AISI304	SUS304	
⑩	Outlet Check Valve CKF3M	Cast Stainless Steel	A351 Gr.CF8	—	

* Equivalent ** Option: Cast Stainless Steel

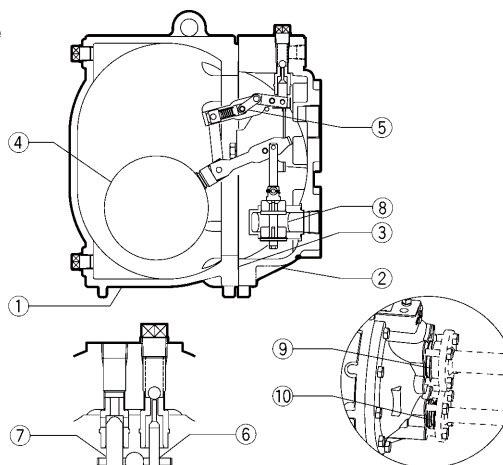

Copyright © TLV

Dimensions

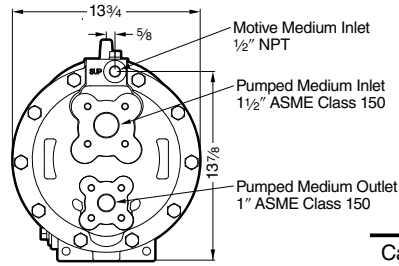
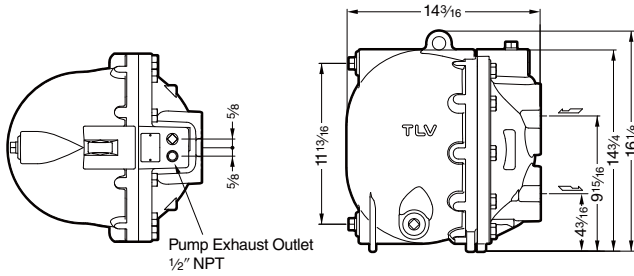

Units: inch

Weight (lb)

Cast Iron	124
Cast Steel	135

Note: All Plug Holes 1/2" NPT

Discharge Capacity

Filling Head: 25" from Grade

Inlet Pipe Size		1 1/2"
Inlet Check Valve		1 1/2" CKF5M
Outlet Check Valve		1" CKF3M
Motive Medium		Steam
Operating Inlet Press. (Pm) psig	Total Lift or Back Press. (P2) psig	lb/h
150	15	4700
	25	4100
	40	3470
	60	2640
	80	2250
125	100	1530
	15	4250
	25	3600
	40	2980
	60	2260
100	80	1800
	100	1190
	15	3860
	25	3230
	40	2530
75	60	1780
	80	1310
	15	3600
	25	2830
	40	2040
50	60	1330
	10	3590
	15	3210
	25	2310
	40	1480
25	5	3660
	10	2790
	15	2230
10	2	3060

• **Correction Factors**

For GT10M installed with filling head other than 25" (minimum filling head: 12")

Filling Head from Grade	Inlet Pipe & Check Valve Size
	1 1/2" CKF5M
55"	1.10
43"	1.08
37"	1.07
31"	1.04
25"	1.00
22"	0.95
18"	0.86
12"	0.60

• **Illustration of Filling Head and Pressures**

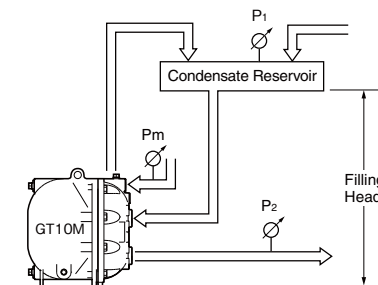

The discharge capacity is determined by the motive medium, motive medium pressure (Pm) and back pressure (P2).

Make sure that:
 Discharge Capacity × Correction Factor > Required Flow Rate

NOTE:

- A check valve must be installed at both the pumped medium inlet and outlet. To achieve the above capacities with the standard GT10M configuration, TLV check valves CKF5M for inlet and CKF3M for outlet must be used.
- Motive steam pressure minus back pressure must be greater than 7 psi.
- A strainer must be installed at the motive medium and pumped medium inlets.

Size of Receiver

The reservoir must have a capacity sufficient to store the condensate produced during the **PowerTrap** operation and discharge.

Reservoir Dimensions (flash steam is not involved)

Amount of condensate lb/h	Reservoir diameter (in) and length (ft)						
	1½	2	3	4	6	8	10
500 or less	3.0 ft	2.0					
700	4.0	2.5	1.0				
1000	5.5	3.5	1.5				
1200		4.5	2.0	1.0			
1500			2.5	1.5			
2000			3.5	2.0			
3000			4.5	3.0			
4000			6.5	4.0	1.5		
5000				5.0	2.5		
6000				5.5	2.5	1.5	
7000				6.5	3.0	1.5	
8000					3.5	2.0	
9000					4.0	2.5	1.5
10000					4.5	2.5	1.5
12000					5.0	3.0	2.0
14000					6.0	3.5	2.5
16000					6.5	4.0	2.5
18000						4.5	3.0
20000						5.0	3.5

Reservoir length can be reduced by 50% when the motive pressure (P_m) divided by the back pressure (P₂) equals 2 or greater (when $P_m \div P_2 \geq 2$).

Steam Consumption (Motive Medium)

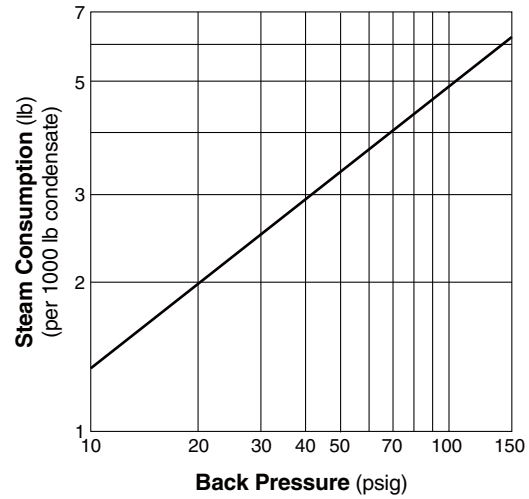

GT10M Steam Trap Discharge Capacity

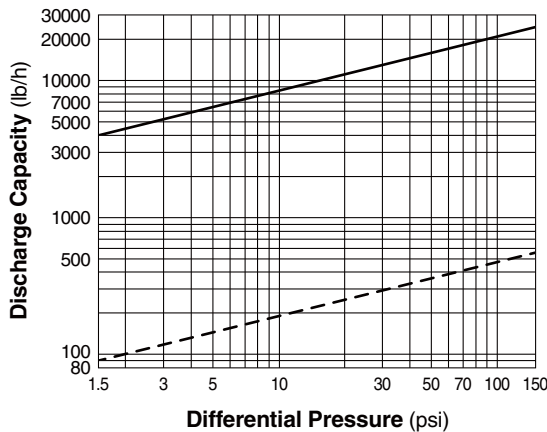

- : Capacity of GT10M as a steam trap (P₁ > P₂). Instantaneous condensate loads above the rated trap capacity will cause the pump to cycle and therefore reduce the discharge capacity.
- - - : Minimum amount of condensate required to prevent steam leakage.

1. Capacities are based on continuous discharge of condensate 11 °F below steam temperature.
2. Differential pressure is the difference between the inlet and outlet pressure of the trap.



DO NOT use this product under conditions that exceed maximum differential pressure, as condensate backup will occur!

Memo:



DO NOT DISASSEMBLE OR REMOVE THIS PRODUCT WHILE IT IS UNDER PRESSURE.
Allow internal pressure of this product to equal atmospheric pressure and its surface to cool to room temperature before disassembling or removing. Failure to do so could cause burns or other injury. READ INSTRUCTION MANUAL CAREFULLY.

TLV CORPORATION

13901 South Lakes Drive, Charlotte, NC 28273-6790
Phone: 704-597-9070 Fax: 704-583-1610
E-mail: tlv@tlvengineering.com
For Technical Service 1-800 "TLV TRAP"



Manufacturer

TLV CO., LTD.
Kakogawa, Japan

is approved by LRQA Ltd. to ISO 9001/14001

ISO 9001/ISO 14001

