

MODEL VR_(H2)

ANSI B16.5 RTJ Weld Neck - Class 1500 or 2500

DESCRIPTION AND GENERAL PERFORMANCE SPECIFICATIONS

The V-Cone® flowmeter is a patented, differential pressure type flow measurement device. A cone is positioned in the center of the pipe to increase the velocity of the flowing fluid and create a differential pressure. This pressure difference can be measured and used to accurately interpret flowrate. Two taps are provided on every V-Cone to allow sensing of the high and low pressures. A typical V-Cone application can follow these general performance specifications:

- Accuracy: up to ±0.5% of rate
- Repeatability: ±0.1%
- Turndown: 10:1
- Standard Betas: 0.45 through 0.85
- Headloss: Percentage of differential pressure produced varies with beta ratio.
- Installation: Typically 0-3 diameters upstream and 0-1 diameters downstream.

Model VR Bulletins
ANSI B16.5 RTJ Weld Neck Flanges
24509-40 Class 150 or 300
24509-41 Class 600 or 900
30121-16 Class 1500 or 2500



The V-Cone is manufactured under a quality management system that is certified to ISO 9001:2015.

* Each V-Cone is sized for the intended application. Specific performance ratings must be obtained through the sizing process.

MODEL VR_(H2) DIMENSIONS

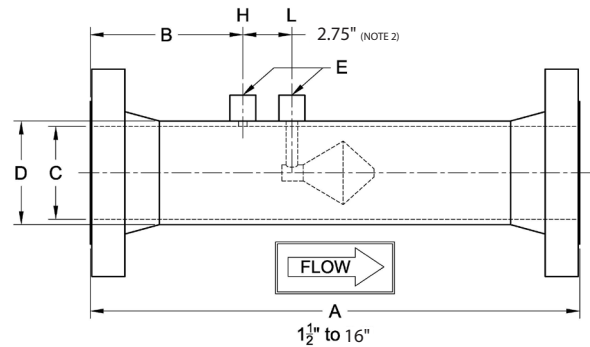
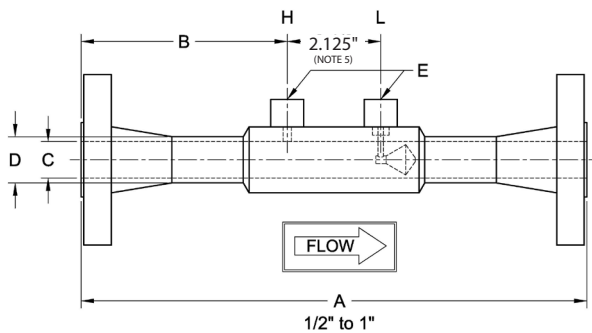

DIMENSION TABLE

Size (Note 4)	RTJ Class 1500						RTJ Class 2500						D		E (Note 2)
	A (Note 1)		B		C (Note 2)		A (Note 1)		B		C (Note 2)				
inch	inch	mm	inch	mm	inch	mm	inch	mm	inch	mm	inch	mm	inch	mm	NPT
1/2	12.875	327.02	5.375	136.52	0.466	11.8	13.875	352.42	5.875	149.22	-	-	0.84	21.3	1/4
3/4	13.625	346.07	5.750	146.05	0.612	15.5	14.375	365.12	6.125	155.57	-	-	1.05	26.7	1/4
1	13.875	352.42	5.875	149.22	0.815	20.7	15.125	384.17	6.500	165.10	0.599	15.2	1.315	33.4	1/4
1 1/2	16.500	419.10	6.250	158.75	1.338	34.0	18.875	479.42	7.438	188.93	1.100	27.9	1.9	48.3	1/4
2	20.000	508.00	7.500	190.50	1.687	42.8	22.000	558.80	8.500	215.90	1.503	38.2	2.375	60.3	1/2
2 1/2	20.125	511.17	7.563	192.10	2.125	54.0	23.250	590.55	9.125	231.77	1.771	45.0	2.875	73.0	1/2
3	23.125	587.37	8.063	204.80	2.624	66.6	27.250	692.15	10.125	257.17	2.300	58.4	3.5	88.9	1/2
4	25.625	650.87	8.813	223.85	3.438	87.3	31.125	790.57	11.563	293.70	3.152	80.1	4.5	114	1/2
6	35.500	901.70	11.000	279.40	5.187	131.7	43.750	1111.2	15.125	384.17	4.897	124.4	6.625	168	1/2
8	42.625	1082.7	13.313	338.15	6.813	173.1	51.125	1298.6	17.563	446.10	6.125	155.6	8.625	219	1/2
10	47.875	1216.0	14.938	379.43	8.500	215.9	61.375	1558.9	21.688	550.88	7.500	190.5	10.75	273	1/2
12	52.375	1330.3	16.438	417.53	10.126	257.2	66.875	1698.6	23.688	601.68	9.000	228.6	12.75	323	1/2
14	52.750	1339.8	17.375	441.32	11.188	284.2	-	-	-	-	-	-	14	355	1/2
16	54.625	1387.5	18.313	465.15	12.812	325.4	-	-	-	-	-	-	16	406	1/2

1. Overall length (A) tolerance varies with line size: 1/2" to 1", ±1/8" (±4mm); 1 1/2" to 10", ±3/16" (±6mm); 12" to 24", ±1/4" (±7mm).
2. Typical values shown.
3. Wall pressure ports are required for vertical up flow applications.
4. All sizes available in Stainless, or higher alloy. Available in CS sizes 1.5" and above only.
5. 1 1/2" meter has 2.125" spacing.