



CLEAN STEAM DIRECT-ACTING PRESSURE REDUCING VALVE

MODEL DR8-P/DR8-EP

COMPACT STAINLESS STEEL DIRECT-ACTING PRV FOR CLEAN STEAM

Benefits

Compact pressure reducing valve for use on autoclaves, sterilizers, humidifiers, etc. in the pharmaceutical, medical, food and other industries.

1. Wetted parts are stainless steel and USP or FDA compliant rubber or resin with high durability and corrosion resistance for long service life.
2. Double-guided valve for stable operation.
3. Internal buff-polishing with an additional interior and exterior electro-polish option to 0.4 μm (16 micro-inch) Ra for improved resistance to bacterial growth.
4. Easy to operate and adjust.
5. Easy access to internal parts simplifies cleaning and reduces maintenance cost.
6. High flow rate for its class.



Specifications

Model	DR8-3P	DR8-6P	DR8-3EP*	DR8-6EP*
Connection	Clamp End			
Size (in)	1/2", 3/4", 1", 1 1/2"			
Maximum Operating Pressure (psig) PMO	115			
Maximum Operating Temperature (°F) TMO	347			
Maximum Allowable Pressure (psig) PMA	150			
Maximum Allowable Temperature (°F) TMA	365			
Primary Pressure Range (psig)	30 to 60	60 to 115	30 to 60	60 to 115
Adjustable Pressure Range (psig)	2.5 to 45	40 to 85	2.5 to 45	40 to 85
Secondary pressure must not exceed 75% of primary pressure				
Finishing**	Internal	0.8 μm (32 micro-inch) Ra Buff-polished		Buff-polished then
	External	25 μm (1000 micro-inch) Ra electro-polished		0.4 μm (16 micro-inch) Ra electro-polished
Applicable Fluid***	Steam			

* Option ** Treated base surfaces are lost-wax cast DR8-P and DR8-EP are non-standard products, consult TLV for delivery time required
 *** Do not use for toxic, flammable, or otherwise hazardous fluids.



To avoid abnormal operation, accidents or serious injury, DO NOT use this product outside of the specification range. Local regulations may restrict the use of this product to below the conditions quoted.

No.	Description	Material	ASTM/AISI ¹⁾	JIS
①	Body	Cast Stainless Steel	A351 Gr.CF3M	—
② ^D	Valve	Stainless Steel	AISI316L	SUS316L
③ ^{MD}	Diaphragm	Silicone Rubber ²⁾	—	—
④ ^{MD}	Protective Sheet	Fluorine Resin ²⁾	PTFE	PTFE
⑤	Spring Case	Cast Stainless Steel	A351 Gr.CF3M	—
⑥	Upper Diaphragm Retainer	Stainless Steel	AISI316L	SUS316L
⑦ ^D	Coil Spring	Stainless Steel	AISI304	SUS304
⑧	Cap	Cast Stainless Steel	A351 Gr.CF3M	—
⑨ ^D	Lower Diaphragm Retainer	Stainless Steel	AISI316L	SUS316L
⑩ ^D	Plain Washer	Stainless Steel	AISI304	SUS304
⑪ ^D	Spring Washer	Stainless Steel	AISI304	SUS304
⑫ ^D	High Nut	Stainless Steel	AISI304	SUS304
⑬ ^D	Spring Retainer	Stainless Steel	AISI304	SUS304
⑭ ^D	Retainer Gasket	Fluorine Resin ²⁾	PTFE	PTFE
⑮	Locknut	Stainless Steel	AISI304	SUS304
⑯ ^D	Adjustment Screw	Stainless Steel	AISI420F	SUS420F
⑰ ^G	Valve Guide	Cast Stainless Steel	A351 Gr.CF3M	—
⑱ ^{MDG}	Inlet Clamp Gasket	High-performance Fluorine Resin ²⁾	—	—
⑲ ^G	Snap Ring	Stainless Steel	AISI316	SUS316CPS
⑳ ^G	Slide Bearing	Polymer Resin ²⁾	—	—
㉑	Body Clamp	Cast Stainless Steel	A351 Gr.CF8	—
㉒	Body Clamp Bolt	Stainless Steel	AISI304	SUS304
㉓	Body Clamp Nut	Stainless Steel	AISI304	SUS304
㉔	Spring Washer	Stainless Steel	AISI304	SUS304
㉕	Inlet Clamp	Cast Stainless Steel	A351 Gr.CF8	—
㉖	Inlet Clamp Bolt	Stainless Steel	AISI304	SUS304
㉗	Inlet Clamp Nut	Stainless Steel	AISI304	SUS304
㉘	Spring Washer	Stainless Steel	AISI304	SUS304
㉙	Adapter	Stainless Steel	AISI316L	SUS316L
㉚ ^D	Coil Spring Guide	Stainless Steel	AISI304	SUS304

Parts with USP/FDA Compliant Materials		Standard		
		USP	FDA*	
⑭	Retainer Gasket	Fluorine Resin	—	A
③	Diaphragm	Silicon Rubber	Class VI	—
④	Protective Sheet	Fluorine Resin	—	—
㉑	Slide Bearing	Polymer Resin	—	B
⑱	Inlet Clamp Gasket	High-performance Fluorine Resin	Class VI	—

* FDA: A: 21 CFR 177.1550, B: 21 CFR 177.2415

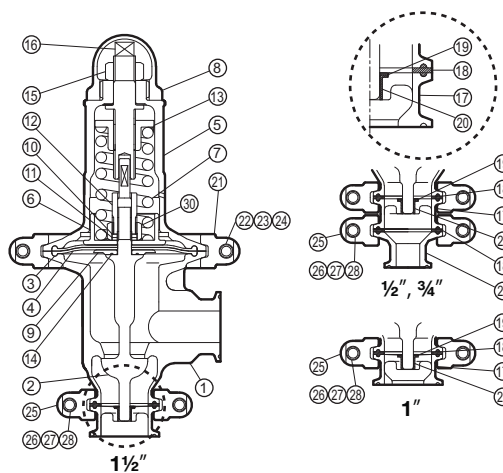

¹⁾ Equivalent ²⁾ USP or FDA compliant material. See the table above-right for details.
 Replacement kits available: (M) maintenance parts, (D) diaphragm and valve repair parts, (G) valve guide repair parts

Dimensions

● **DR8-P/DR8-EP** Clamp End

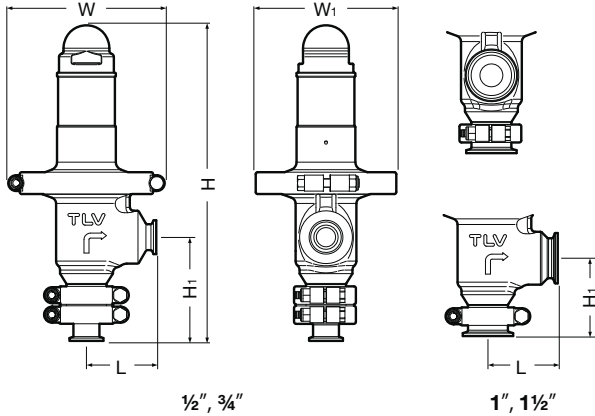

DR8-P/DR8-EP Clamp End* (in)

Size	L	H**	H1**	W	W1	Weight (lb)
1/2"	2 3/4	12 1/16	4 1/4	6 3/4	5 3/8	11
3/4"		11 5/8	3 1/8			10.9
1"						10.9
1 1/2"						

* ASME-BPE (Tri-Clamp compatible) or ISO 2852 Clamp / ISO 2037 Tube
 ** Approximate dimensions

Clamp End Dimensions

Size	φ d	φ D
1/2"	3/8 (5/8)	1 (1 1/8)
3/4"	5/8 (7/8)	
1"	7/8 (1)	2
1 1/2"	1 3/8 (1 13/32)	

() ISO 2852 Clamp / ISO 2037 Tube

Tri-Clamp is a registered trademark of Alfa Laval Corporate AB.

Capacity Table (Max. Flow Rate)

The following tables are used for sizing the DR8 when adjusted for maximum flow.

		DR8-3P DR8-3EP			
P ₁ (psig)	P ₂ (psig)	Nominal Valve Size			
		1/2"	3/4"	1"	1 1/2"
30	**22	320	380	430	840
	20	360	420	480	960
	15	430	500	570	1130
	10	470	550	630	1260
	*2.5-7	500	580	660	1320
35	**26	360	420	480	950
	25	380	440	510	1010
	20	450	530	600	1200
	15	510	590	680	1350
	*2.5-10	550	640	730	1470
40	**30	400	470	530	1070
	25	480	560	640	1280
	20	540	630	720	1430
	15	580	680	780	1560
	*2.5-10	610	710	810	1610
45	**33	460	530	610	1190
	30	500	590	670	1340
	25	570	660	760	1510
	20	620	720	820	1650
	*2.5-15	660	770	880	1760
50	**37	500	580	660	1300
	35	530	610	700	1400
	30	600	690	790	1590
	25	650	760	870	1730
	20	690	810	930	1850
55	*2.5-15	720	840	960	1910
	**41	530	620	710	1410
	40	550	640	730	1470
	35	620	730	830	1660
	30	680	790	910	1810
60	25	730	850	970	1940
	*2.5-20	770	900	1030	2060
	**45	570	670	760	1520
	40	650	760	860	1730
	35	710	830	950	1890
60	30	760	890	1010	2030
	25	800	940	1070	2150
	*2.5-20	830	960	1100	2200

		DR8-6P DR8-6EP			
P ₁ (psig)	P ₂ (psig)	Nominal Valve Size			
		1/2"	3/4"	1"	1 1/2"
60	**45	570	670	760	1520
	*40	650	760	860	1730
	**52	660	770	890	1750
	50	650	810	930	1850
	45	760	890	1020	2040
70	*40	820	960	1100	2190
	**56	700	820	940	1870
	55	720	840	960	1910
	50	790	920	1050	2010
	45	850	1000	1140	2270
80	*40	900	1060	1210	2410
	**60	740	860	990	1970
	55	820	950	1090	2180
	50	880	1030	1170	2340
	45	940	1090	1250	2490
85	*40	980	1150	1310	2620
	**63	790	930	1060	2080
	60	840	980	1120	2240
	55	910	1060	1210	2420
	50	960	1130	1290	2570
90	45	1020	1180	1350	2710
	*40	1060	1240	1410	2830
	**67	820	960	1100	2200
	65	860	1010	1150	2300
	60	930	1090	1240	2490
95	55	990	1160	1320	2650
	50	1050	1220	1400	2790
	45	1100	1280	1460	2920
	*40	1140	1320	1510	3030
	**71	870	1010	1150	2310
100	70	890	1030	1180	2360
	65	960	1120	1280	2560
	60	1020	1190	1360	2720
	55	1080	1260	1440	2870
	50	1130	1310	1500	3000
100	*40-45	1170	1370	1560	3120
	**75	910	1060	1210	2420
	70	980	1150	1310	2620
	65	1050	1220	1400	2800
	60	1110	1290	1480	2950
100	55	1160	1350	1540	3090
	50	1200	1410	1610	3210
	45	1250	1450	1660	3320
	*40	960	1120	1280	2530

		DR8-6P DR8-6EP			
P ₁ (psig)	P ₂ (psig)	Nominal Valve Size			
		1/2"	3/4"	1"	1 1/2"
105	**78	960	1120	1280	2530
	75	1010	1180	1340	2690
	70	1080	1260	1430	2870
	65	1140	1330	1510	3030
	60	1190	1390	1590	3170
	55	1230	1450	1670	3300
	50	1280	1490	1710	3410
	*40-45	1330	1550	1770	3530
	**82	1000	1170	1340	2650
	80	1030	1200	1380	2750
110	75	1100	1290	1470	2940
	70	1160	1360	1550	3100
	65	1220	1420	1630	3250
	60	1270	1480	1690	3390
	55	1320	1530	1750	3510
	50	1360	1570	1810	3610
	*40-45	1380	1610	1840	3680
	**86	1060	1230	1410	2770
	80	1130	1320	1500	3000
	75	1190	1390	1590	3180
115	65	1300	1520	1740	3470
	60	1350	1570	1790	3600
	55	1390	1620	1850	3710
	*40-50	1440	1680	1910	3830

P₁ = Primary pressure
 P₂ = Secondary pressure
 * Minimum adjustable secondary pressure
 ** Maximum adjustable secondary pressure

Cv Values

Size (in)	1/2"	3/4"	1"	1 1/2"
Cv (US)	6	7	8	16
Cv (UK)	5	5.8	6.7	13.7
Kvs (DIN)	5.1	6	6.8	13.3

Cv & Kvs values are for maximum flow



DO NOT DISASSEMBLE OR REMOVE THIS PRODUCT WHILE IT IS UNDER PRESSURE.
 Allow internal pressure of this product to equal atmospheric pressure and its surface to cool to room temperature before disassembling or removing. Failure to do so could cause burns or other injury. READ INSTRUCTION MANUAL CAREFULLY.

TLV CORPORATION

13901 South Lakes Drive, Charlotte, NC 28273-6790
 Tel: 704-597-9070 Fax: 704-583-1610
 E-mail: tlv@tlvengineering.com <https://www.tlv.com>
 For Technical Service 1-800 "TLV TRAP"



Manufacturer
TLV CO., LTD.
 Kakogawa, Japan
 is approved by LRQA Ltd. to ISO 9001/14001

