



# PowerTrap®

## MODEL GP14L

### SECONDARY PRESSURE DRAINER FOR PUMPING APPLICATIONS

#### Benefits

**Pump for a wide range of applications. Ideal for medium flow condensate removal from vented receivers situated at a low level.**

1. No cavitation or seal leakage.
2. Non-electric design with durable nickel-based alloy compression spring for reliable performance.
3. Pump will operate with a low filling head (min. 12").
4. Easy, inline access to internal parts simplifies cleaning and reduces maintenance costs.
5. Intake/exhaust valve heads are both Rockwell 65C with 45C seats for maximum durability.
6. High quality stainless steel internals ensure reliability.
7. Compact design permits installation in a limited space.
8. Float resists hydraulic shock to 1500 psig.
9. 2-year warranty for snap-action mechanism.\*
10. Cycle Counter installable as option.

\* Contact TLV for details



#### Specifications

Model		GP14L
Connection	Pumped Medium Inlet & Outlet	<b>Flanged*</b>
	Motive Medium & Pump Exhaust	Screwed
Size (in)	Pumped Medium: Inlet x Outlet	<b>1½ x 1</b>
	Motive Medium Inlet	½
	Pump Exhaust Outlet	½
Maximum Operating Pressure (psig)	PMO	200
Maximum Operating Temperature (°F)	TMO	428
Maximum Allowable Pressure (psig)	PMA	Cast Iron: 230 Cast Steel: 300
Maximum Allowable Temperature (°F)	TMA	Cast Iron: 428 Cast Steel: 500
Motive Medium Pressure Range (psig)		5 – 200
Maximum Allowable Back Pressure		7 psi less than motive medium pressure used
Volume of Each Discharge Cycle (gal)		Approx. 2
Motive Medium**		Saturated Steam, Compressed Air, Nitrogen
Pumped Medium***		Steam Condensate, Water

\* For details of flange connection, see picture at bottom right.

\*\* Do not use with toxic, flammable or otherwise hazardous fluids.

\*\*\* Do not use for fluids with specific gravities under 0.85 or over 1, or for toxic, flammable or otherwise hazardous fluids.

**Connections and sizes in bold are standard**



To avoid abnormal operation, accidents or serious injury, DO NOT use this product outside of the specification range. Local regulations may restrict the use of this product to below the conditions quoted.

No.	Description	Material	ASTM/AISI*	JIS
①	Body	Cast Iron	A126 Cl.B	FC250
		Cast Steel**	A216 Gr.WCB	—
②	Cover	Cast Iron	A126 Cl.B	FC250
		Cast Steel**	A216 Gr.WCB	—
③	Cover Gasket	Graphite Compound	—	—
④	Float	Stainless Steel	AISI316L	SUS316L
⑤	Snap-action Unit	Stainless Steel	—	—
⑥	Motive Medium Intake Valve Unit	Intake Valve	AISI440C	SUS440C
		Valve Seat	AISI420F	SUS420F
⑦	Exhaust Valve Unit	Exhaust Valve	AISI440C	SUS440C
		Valve Seat	AISI420F	SUS420F
⑧	Inlet Check Valve CKF5M	Stainless Steel	AISI304	SUS304
⑨	Outlet Check Valve CKF3M	Cast Stainless Steel	A351 Gr.CF8	—

\* Equivalent \*\* Option: Cast Stainless Steel

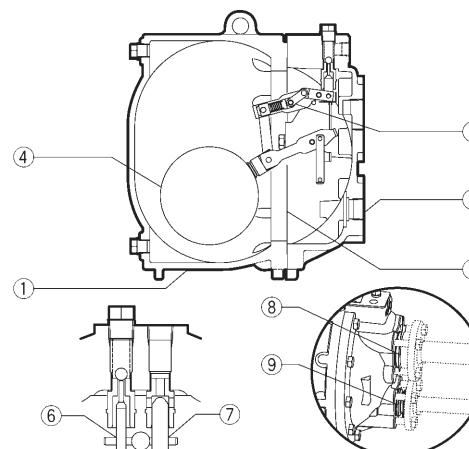

**Dimensions**

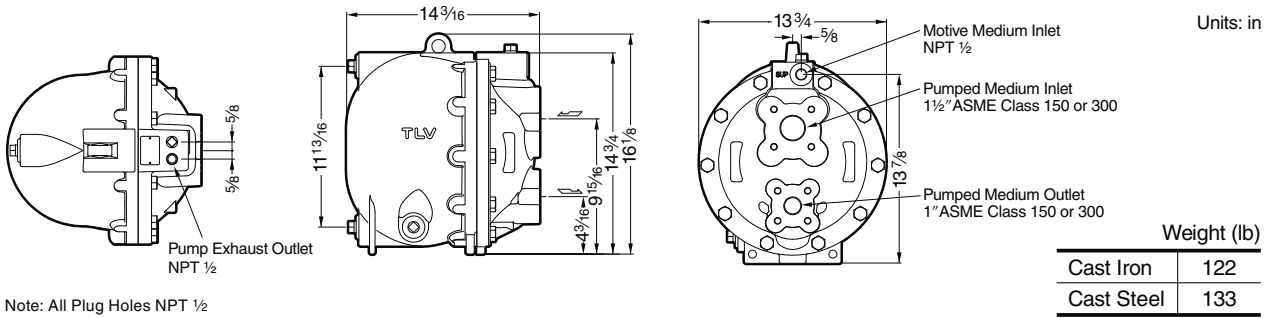

**Discharge Capacity**

Filling Head 25" from Grade

Inlet Pipe Size		1 1/2"	
Inlet Check Valve		1 1/2" CKF5M	
Outlet Check Valve		1" CKF3M	
Motive Medium		Air	Steam
Motive Medium Inlet Pressure (Pm) (psig)	Total Lift or Back Press. (P2) psig	lb/h	lb/h
200	25	4800	4410
	40	4430	3550
	60	4150	3090
	80	3950	2380
	100	3420	1850
175	150	2800	1120
	25	4650	4190
	40	4370	3480
	60	4010	2870
	80	3820	2210
150	100	3330	1740
	150	2670	930
	15	4850	4700
	25	4590	4150
	40	4300	3310
125	60	3770	2650
	80	3550	1990
	100	3090	1610
	15	4740	4540
	25	4370	3790
100	40	3970	3040
	60	3590	2320
	80	3200	1720
	100	2840	1270
	15	4590	4120
75	25	4190	3400
	40	3770	2580
	60	3400	1900
	80	2910	1320
	15	4370	3570
50	25	4060	2980
	40	3570	2010
	60	3150	1410
	10	4320	3750
	15	4190	3200
25	25	3810	2400
	40	3310	1480
	5	4500	3750
	10	3900	3000
	15	3660	2390
10	2	4130	3110

● **Correction Factor**

For GP14L installed with filling head other than 25" (minimum filling head: 12")

Filling Head from Grade	Inlet Pipe & Check Valve Size
	1 1/2" CKF5M
55"	1.10
43"	1.09
37"	1.07
31"	1.05
25"	1.00
22"	0.94
18"	0.82
12"	0.60

● **Illustration of Filling Head and Pressures**

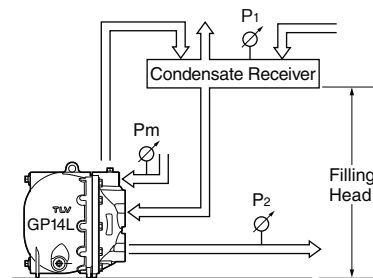

The discharge capacity is determined by the motive medium, motive medium pressure (Pm) and back pressure (P2).

Make sure that:  
 Discharge Capacity × Correction Factor > Required Flow Rate

**NOTE:**

- A check valve must be installed at both the pumped medium inlet and outlet. To achieve the above capacities with the standard GP14L configuration, TLV check valves CKF5M for inlet and CKF3M for outlet must be used.
- Motive steam pressure minus back pressure must be greater than 7 psi.
- In closed system applications, the motive medium must be compatible with the liquid being pumped. If a non-condensable gas such as air or nitrogen is used as the motive medium, consult TLV for assistance.
- A strainer must be installed at the motive medium and pumped medium inlets.

## Size of Receiver/Reservoir

The receiver/reservoir must have a capacity sufficient to store the condensate produced during the **PowerTrap** operation and discharge. A receiver will generally be larger than a reservoir because it must handle the condensate both as a liquid and as flash steam, and separate one from the other so that only condensate is sent to the **PowerTrap**.

If NO flash steam is present, use dimensions given in table ②. If flash steam is present, compare tables ① & ② and choose the larger resultant size. For all open systems, use table ① to select a suitable vent pipe diameter.

### ① Receiver Dimensions (Length: 3.5 ft)

Flash steam up to lb/h	Receiver diameter in	Vent pipe diameter in
50	3	1
75	4	1 ½
100	4	2
200	6	2 ½
300	8	3
400	8	4
600	10	4
800	12	6
1,000	14	6
1,400	16	8
1,600	18	8
2,000	20	8

### ② Reservoir Dimensions

Amount of Condensate (lb/h)	Reservoir Diameter (in) and Length (ft)						
	1 ½	2	3	4	6	8	10
500 or less	3.0 ft	2.0					
700	4.0	2.5	1.0				
1,000	5.5	3.5	1.5				
1,200		4.5	2.0	1.0			
1,500			2.5	1.5			
2,000			3.5	2.0			
3,000			4.5	3.0			
4,000			6.5	4.0	1.5		
5,000				5.0	2.5		
6,000				5.5	2.5	1.5	
7,000				6.5	3.0	1.5	
8,000					3.5	2.0	
9,000					4.0	2.5	1.5
10,000					4.5	2.5	1.5
12,000					5.0	3.0	2.0
14,000					6.0	3.5	2.5
16,000					6.5	4.0	2.5
18,000						4.5	3.0
20,000						5.0	3.5

Reservoir length can be reduced by 50% when the motive pressure (P<sub>m</sub>) divided by back pressure (P<sub>2</sub>) equals 2 or greater (when  $P_m \div P_2 \geq 2$ ).

## Steam or Air Consumption (Motive Medium)

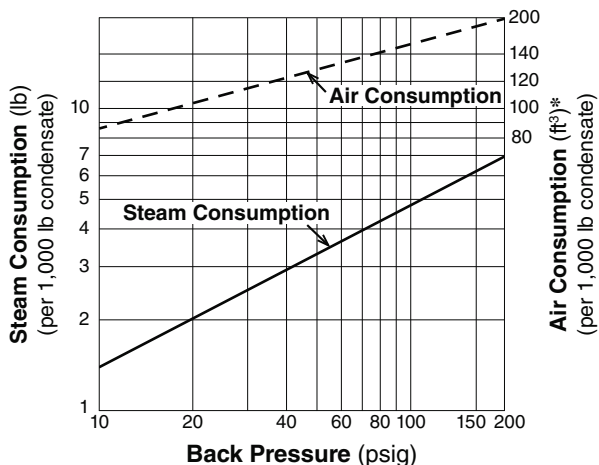

\* Equivalent consumption of air at 68 °F under atmospheric pressure

## Cycle Counter (option)

Two types of counter can be installed on the GP14L to monitor the number of pumping cycles and help to determine the timing of maintenance, or estimate the volume of pumped condensate.

- **C1CM – (Counter Unit Type):**  
Self-contained standalone unit. Includes an LCD counter display and an operation indicator LED.
- **C1SM – (Terminal Box Type):**  
Designed for use with remote monitoring equipment and systems.

Intrinsically safe models are also available.  
See the Cycle Counter SDS for further details

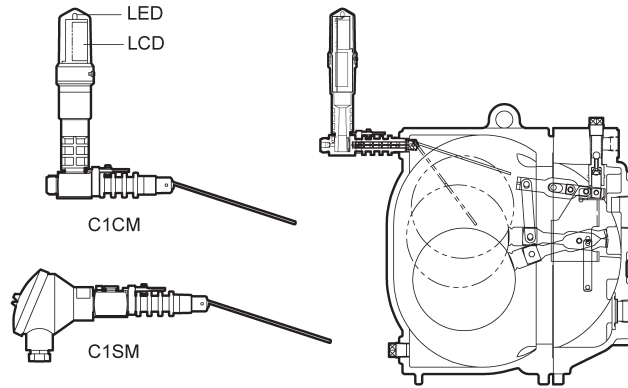

**DO NOT DISASSEMBLE OR REMOVE THIS PRODUCT WHILE IT IS UNDER PRESSURE.**  
Allow internal pressure of this product to equal atmospheric pressure and its surface to cool to room temperature before disassembling or removing. Failure to do so could cause burns or other injury. **READ INSTRUCTION MANUAL CAREFULLY.**

## TLV CORPORATION

13901 South Lakes Drive, Charlotte, NC 28273-6790  
Phone: 704-597-9070 Fax: 704-583-1610  
E-mail: [tlv@tlvengineering.com](mailto:tlv@tlvengineering.com)  
For Technical Service 1-800 "TLV TRAP"



Manufacturer  
**TLV CO., LTD.**  
Kakogawa, Japan  
is approved by LRQA Ltd. to ISO 9001/14001

ISO 9001/ISO 14001

