

# TLV<sup>®</sup>

## CYCLONE SEPARATORS

## DC Series



# CONDENSATE ENTRAINED IN STEAM AND AIR WILL BE REMOVED WITH 98% EFFICIENCY

## CONSTRUCTION (DC3S)

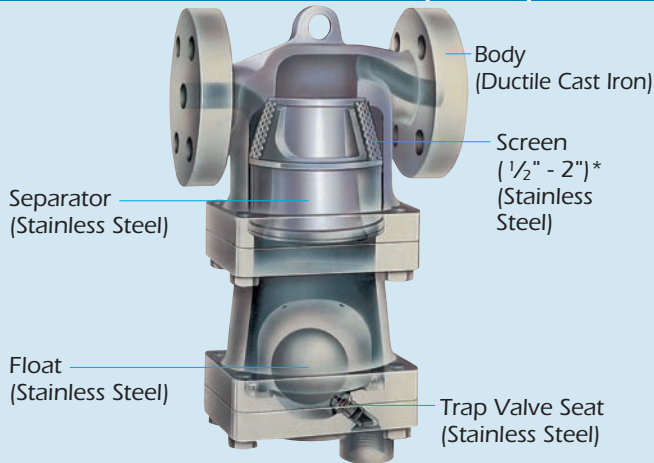

\* Screen for sizes 3" and 4" is in Trap Cover

## FEATURES AND BENEFITS

### 1. Cyclone-Effect Separator:

- Unique cyclone separator's efficiency can deliver steam up to 99.8% dryness.\*
- Improves productivity and product quality with dry, high-quality steam/air.

### 2. Free-Float Trap: (DC3 and DC7 need a separate trap)

- Continuously discharges condensate as it is separated.
- Provides a complete seal, even under low load conditions, with its precision ground spherical float and positive three-point seating.

\* Under normal operating conditions

## OPERATION

### During Separation

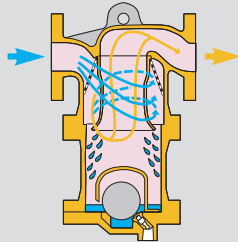

### During Discharge

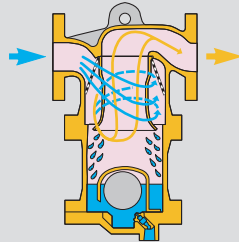

**1** Fluid enters the inlet of the separator, and a complex series of fins changes the steam or air flow into a high-speed cyclone flow, separating even mist-like condensate.

**2** The separated condensate accumulates at the bottom, lifting the float off the valve seat and discharging condensate continuously.

## FLOW VELOCITY AND EFFICIENCY

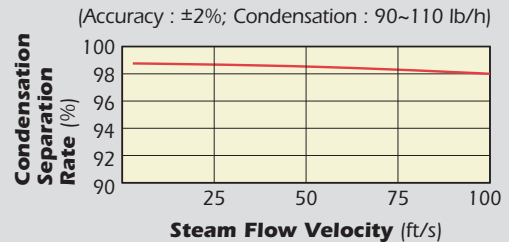

Separation rate (%) is given as:  

$$\frac{\text{quantity of condensate discharged}}{\text{quantity of incoming condensate}} \times 100$$

## SPECIFICATIONS

Model	Type	Connection	Sizes	Body Material	Maximum Operating Pressure (psig) PMO	Max. Differential Pressure (psi) Δ PMX (Built-in Trap)	Maximum Operating Temperature (°F) TMO
	DC3S Steam Separator Trap	Screwed	1/2, 3/4, 1	Ductile Cast Iron	150, 300	150, 300	428
		Flanged	1 1/2, 2, 3, 4				
	DC3A Air Separator Trap	Screwed	1/2, 3/4, 1	Cast Iron Ductile for 3" and 4"	150	150	212
		Flanged	1 1/2, 2, 3, 4				
	DC3 Steam/Air Separator	Flanged	6	Ductile Cast Iron	300	-	428
		Screwed	1/2, 3/4, 1, 1 1/2, 2				
	DC7 Steam/Air Separator	Flanged	1 1/2, 2	Stainless Steel	362	-	572
		Screwed	1/2, 3/4, 1, 1 1/2, 2				

Full product details (sizes, pressures, capacities and materials) are included in the individual specification data sheets (SDS). Do not use for toxic, flammable or otherwise hazardous fluids.



To avoid abnormal operation, accidents or serious injury, DO NOT use this product outside of the specification range. Local regulations may restrict the use of this product to below the conditions quoted.

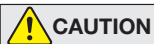

DO NOT DISASSEMBLE OR REMOVE THIS PRODUCT WHILE IT IS UNDER PRESSURE. Allow internal pressure of this product to equal atmospheric pressure and its surface to cool to room temperature before disassembling or removing. Failure to do so could cause burns or other injury.

## LARGER SIZES

For larger sizes, carbon steel fabricated cyclone separators stamped to ASME code for unfired pressure vessels (ASME Code Section VIII, Div. I) are available in sizes up to 20" with maximum operating pressures up to 550 psig. See the DC-L Series SDS for details.



## TLV CORPORATION

13901 South Lakes Drive, Charlotte, NC 28273-6790

Tel: 704-597-9070 Fax: 704-583-1610

E-mail: [tlv@tlvengineering.com](mailto:tlv@tlvengineering.com) <http://www.tlv.com>

For Technical Service 1-800 "TLV TRAP"



Manufacturer

**TLV** CO., LTD.

Kakogawa, Japan

is approved by LRQA Ltd, to ISO 9001/14001

ISO 9001  
ISO 14001

