



STEAM PRESSURE REDUCING VALVE

MODEL COSR-21

SELF-ACTUATED PRESSURE REDUCING VALVE WITH UNIQUE PISTON DESIGN

Benefits

Technologically advanced pressure reducing valve for accurate control in process steam systems.

1. Unique Shock-Absorbing Spherical (SAS) piston delivers stable secondary pressure.
2. Valve maintains high accuracy during severe conditions of varying primary pressure and fluctuating flow rates.
3. Unique self-aligning piston design provides for maximum reliability.
4. Unique pilot valve and two-piece main valve designs assure seal tight shut-off in dead end service.
5. Internal screen for pilot valve extends trouble-free service.
6. Designed with PTFE gaskets for inspection ease.
7. Capable of internal secondary pressure sensing for compact space installation.

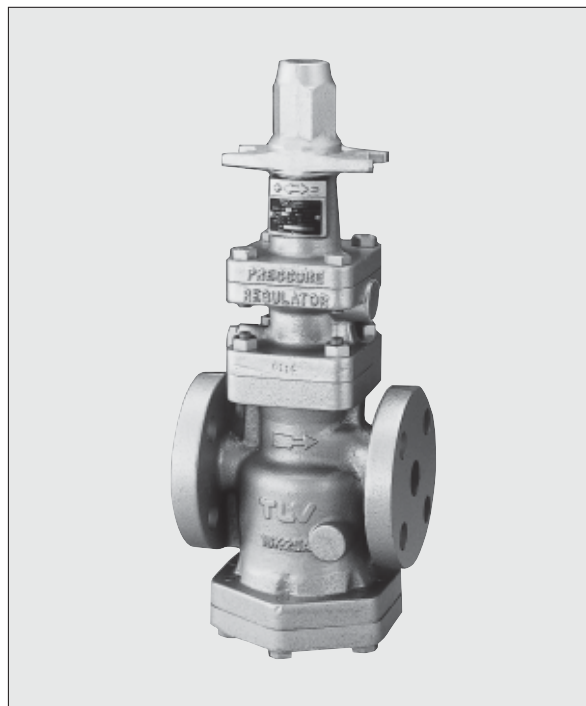

Specifications

Model	COSR-21	
Connection	Screwed	Flanged
Size (in)	1/2, 3/4, 1	1, 1 1/2, 2
Body Material	Ductile Cast Iron	
Max. Operating Pressure (psig)	PMO	300
Max. Operating Temperature (°F)	TMO	428
Maximum Allowable Pressure (psig)	PMA	300
Maximum Allowable Temperature (°F)	TMA	428
Primary Pressure Range (psig)	190 – 300	
Adjustable Differential Pressure (psig)	30 – 120	
Pressure Adjustment Range (psig)	80 – 252	
Maximum Adjustable Secondary Pressure (psig)	84% of Primary Pressure	
Minimum Adjustable Secondary Pressure (psig)	80 psig (or Primary Pressure minus 120 psi, whichever is higher)	
Minimum Adjustable Flow Rate	5% of rated flow rate	
Accuracy of Regulation (psi)	AOR	±1 (under steady flow conditions)
Seal Leakage Rating	Less than 0.1% of Rated Flow Rate	

COSR-21 is a non-standard product; consult TLV for delivery time required.



To avoid abnormal operation, accidents or serious injury, DO NOT use this product outside of the specification range. Local regulations may restrict the use of this product to below the conditions quoted.

Configuration

No.	Description	Material
①	Main Body	Ductile Cast Iron
②	Cover	Ductile Cast Iron
③	Main Valve Seat	Stainless Steel
④	Main Valve	Stainless Steel
⑤	Main Valve Holder	Stainless Steel
⑥	Piston	Stainless Steel
⑦	Cylinder	Stainless Steel
⑧	Pilot Valve Body	Ductile Cast Iron
⑨	Pilot Valve	Stainless Steel
⑩	Pilot Valve Seat	Stainless Steel
⑪	Diaphragm	Stainless Steel
⑫	Pilot Screen	Stainless Steel
⑬	Pilot Screen Holder	Carbon Steel
⑭	Diaphragm Support	Brass
⑮	Coil Spring	Carbon Steel
⑯	Spring Housing	Ductile Cast Iron
⑰	Adjustment Screw	Cr-Mo Steel
⑱	Spanner Cap	Die Cast Aluminium
⑲	Plug – Cover	Carbon Steel
⑳	Nameplate	Stainless Steel

Contact TLV for available replacement parts. All gaskets are PTFE.

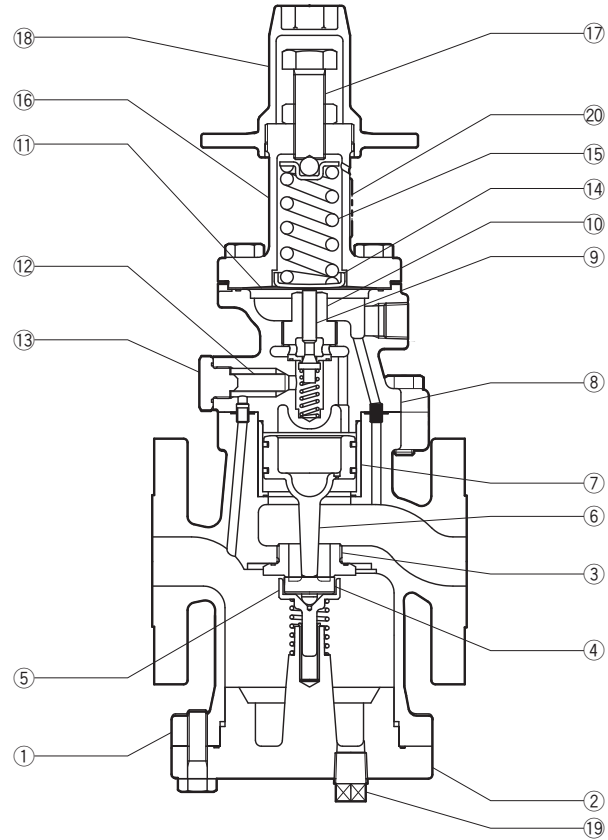

Cv Values

	Nominal Valve Size				
	1/2"	3/4"	1"	1 1/2"	2"
Cv (US)	3.8	6.9	11.1	24.0	37.2
Cv (UK)	3.2	5.7	9.2	20.0	31.0
Kvs (DIN)	3.3	5.9	9.5	20.6	31.9

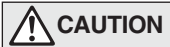

The Cv values shown are for the valve in the full fail open position. These values are not to be used for COSR sizing, and instead may be used as one of the factors in calculations for safety valve selection.

Capacity Table

With external (factory standard) or internal (option) secondary pressure-sensing line or channel (lb/h)

Primary Steam Press. (psig)	Secondary (Set) Steam Pressure (psig)		Nominal Valve Size				
	External Line	Internal Channel (option)	½"	¾"	1"	1½"	2"
190	*160	*160	660	900	1340	2640	4400
	150	150	790	1120	1760	3300	5060
	125	125	900	1320	1980	3960	6160
	100	100	1120	1690	2420	5280	7700
	**80 – 95	95	1180	1780	2540	5540	8090
		**80	810	1120	1760	3300	5060
200	*168	*168	660	950	1390	2640	4400
	160	160	730	1100	1540	2860	4840
	150	150	880	1320	1940	3740	5940
	125	125	1030	1540	2200	4620	6820
	**80 – 100	100	1210	1760	2860	5500	8140
		**80	880	1320	1910	3740	5720
210	*176	*176	700	1060	1540	2860	4840
	175	175	730	1080	1560	2900	4880
	150	150	1010	1520	2200	4620	7040
	125	125	1140	1720	2640	5060	7480
	**90 – 105	105	1250	1870	2890	5540	8550
		100	1190	1780	2750	5280	8140
		**90	1030	1540	2200	4620	7040
225	*189	*189	700	1030	1540	2860	4840
	185	185	730	1060	1560	2970	4950
	175	175	880	1280	1870	3520	5940
	150	150	1140	1740	2640	5060	7920
	125	125	1320	1940	2860	5940	9020
		**105 – 113	1450	2130	3150	6530	9920
		**105	1170	1780	2640	5500	8140
240	*202	*202	700	1030	1540	2860	4840
	200	200	730	1060	1560	2970	4950
	175	175	1080	1540	2200	4840	6930
	150	150	1360	1980	3190	6380	9240
	125	125	1540	2200	3520	6820	10560
		**120	1630	2420	3960	7920	11440
250	*210	*210	840	1120	1760	3300	5060
	200	200	950	1360	1980	3960	6380
	175	175	1320	1940	2860	5940	8800
	150	150	1720	2420	3960	7920	11220
		**130	1800	2860	4510	8800	12760
260	*218	*218	860	1230	1800	3520	5280
	210	210	900	1320	1890	3740	5940
	200	200	1060	1540	2200	4620	7040
	175	175	1360	2000	3080	6380	9460
	150	150	1760	2640	4400	8360	12100
		**140	1850	2860	4620	8800	13200
275	*231	*231	860	1210	1800	3520	5500
	225	225	920	1360	1980	3960	6160
	200	200	1230	1800	2860	5500	8360
	175	175	1630	2420	3740	7480	11220
		**155	1980	3300	5060	9900	14520
290	*244	*244	880	1320	1850	3520	5940
	240	240	950	1360	2000	4180	6380
	225	225	1120	1650	2420	4840	7480
	200	200	1500	2130	3520	6820	9900
	175	175	1910	2860	4620	9240	13640
		**170	1940	2970	4840	9680	14080
300	*252	*252	970	1410	2050	4400	6600
	250	250	1080	1540	2310	4730	7040
	225	225	1390	2000	3190	6380	9240
	200	200	1780	2640	4510	8580	12760
		**180	2020	3300	5060	10340	15400

* Maximum adjustable secondary pressure ** Minimum adjustable secondary pressure

Dimensions

● **COSR-21** Screwed

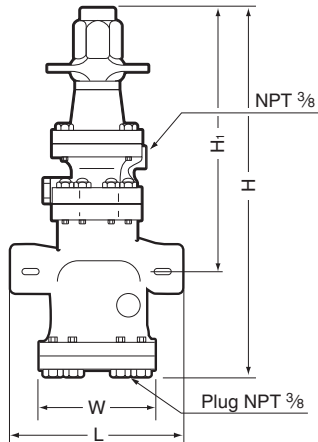

COSR-21 Screwed* (in)

Size	L	H	H ₁	W	Weight (lb)
1/2	6 7/8	16	12	4 1/8	24
3/4					29
1	7 1/2	16 5/8	11 7/8	4 15/16	31

* NPT, other standards available

● **COSR-21** Flanged

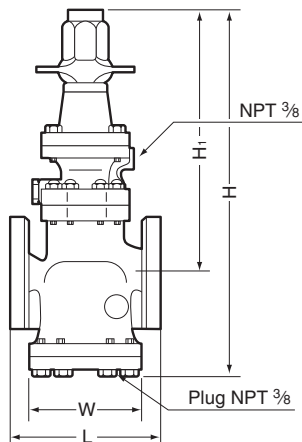

COSR-21 Flanged (in)

Size	L	H	H ₁	W	Weight (lb)
	Connects to ASME Class				
	300RF				
1	7 3/8	16 5/8	4 7/8	4 15/16	33
1 1/2	8 3/4	18	12 11/16	5 7/8	46
2	10 1/4	19 5/16	13 3/16	7 11/16	79

Other standards available, but length and weight may vary

Size 1" shown.
Configuration of larger sizes differs slightly



DO NOT DISASSEMBLE OR REMOVE THIS PRODUCT WHILE IT IS UNDER PRESSURE.
Allow internal pressure of this product to equal atmospheric pressure and its surface to cool to room temperature before disassembling or removing. Failure to do so could cause burns or other injury. READ INSTRUCTION MANUAL CAREFULLY.

TLV CORPORATION

13901 South Lakes Drive, Charlotte, NC 28273-6790
Tel: 704-597-9070 Fax: 704-583-1610
E-mail: tlv@tlvengineering.com <https://www.tlv.com>
For Technical Service 1-800 "TLV TRAP"



Manufacturer
TLV CO., LTD.
Kakogawa, Japan
is approved by LRQA Ltd. to ISO 9001/14001

