

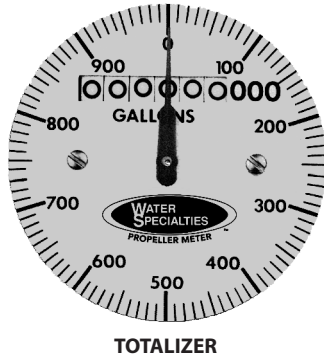

MODEL LP31
 150 psi STRAP-ON SADDLE METER
 SEALED METER MECHANISM - MAGNETIC DRIVE
 STAINLESS STEEL STRAP-ON SADDLE
 SEALED TOTALIZER
 SIZES 4" thru 20"



DESCRIPTION

MODEL LP31 STRAP-ON SADDLE METERS are designed for irrigation or other low pressure service up to 150 PSI working pressure. The stainless steel saddle (brass 4") and u-straps permit installation on a wide range of steel, cast-iron, plastic (3/16" PVC wall minimum), asbestos, and other pipe materials for each nominal meter size. It is necessary upon ordering to furnish the I.D. dimension of the pipe the meter is to be mounted on, for calibration purposes. The pipe O.D. dimension (20" max.) or wall thickness must also be furnished for proper sizing of the U-straps. NOTE: Consult factory for O.D. larger than 20".

INSTALLATION is made by cutting a hole in the existing pipe line and then attaching the meter securely to the line. U-straps for attaching the meter saddle to the line are furnished with each meter. The meter can be installed in any of the following positions: vertically, horizontally, or inclined on suction or discharge lines. The meter must have a full flow of liquid for proper accuracy. Fully opened gate valves, fittings, or other obstructions that tend to set up flow disturbances should be a minimum of ten pipe diameters upstream and two pipe diameters downstream from the meter. Installations with less than ten pipe diameters of straight pipe require straightening vanes. Meters with straightening vanes require at least five pipe diameters upstream and two pipe diameters downstream.

PROPELLER is magnetically coupled with the drive mechanism through the sealed oil filled gearbox. This completely eliminates water entering the meter assembly, as well as the need for any packing gland. The propeller is a conical shaped three bladed propeller, injection molded of thermoplastic material resistant to normal water corrosion and deformity due to high flow velocities.

BEARING in propeller is a water lubricated ceramic sleeve and spindle bearing system with a ceramic/stainless steel spindle. Dual ceramic thrust bearings, standard on all meters, handle flows in both forward and reverse directions. The bearing design promotes extended periods of maintenance free propeller operation.

TOTALIZER is o-ring sealed and magnetically coupled with the driving mechanism, and features a six digit totalizer with a full 3" diameter, 100 division, center sweep dial that permits extremely accurate readings for timing purposes in determining flow rates. The totalizer dial can be furnished in gallons, cubic feet, acre feet, or any standard liquid measuring units. The bonnet, with padlock hasp, can be positioned in four different directions for the easiest possible reading when the meters are mounted in unusual positions.

CHANGE GEARS may be easily exchanged in the field when changing the dial, or when recalibrating for different pipe sizes. It is not necessary to remove pressure from the line for these changes.

O-RING SEALS are used at the meter head and all points where seals are required, making the meter mechanism completely immune to any of the corrosive effects of atmospheric moisture or the liquids measured by the meter assembly.

SPECIFICATIONS

ACCURACY	Plus or minus 2% of actual flow within the range specified for each meter size.
PRESSURE RANGE	Up to 150 PSI maximum working pressure.
TEMPERATURE RANGE	140° F Maximum. Consult factory for special construction for higher temperatures.
MINIMUM FLOWS	As shown for each meter size and construction are required for accurate registration. See flow chart. NOTE: Minimum flow will be higher when auxiliary equipment is added.
MAXIMUM FLOWS	As shown for each meter size and construction are rated for continuous operation. See flow chart.
INTERMITTENT FLOWS	As shown for each meter size are rated for 10% to 15% of the total time the meter is operating. Consult factory for High Velocity construction when intermittent flows are higher than shown on flow chart and/or when longer operating periods are required.
MATERIALS	Used in construction are chosen to minimize the corrosive effects of the liquids measured by the meter assembly. MAGNETS - anticorrosive aluminized barrier coated magnets; Everlube 6155 VERTICAL SHAFT BEARING - shielded stainless steel PROPELLER BEARING - ceramic sleeve type PROPELLER SPINDLE - ceramic sleeve/stainless steel PROPELLER - injection molded thermoplastic GEARBOX - stainless steel SEPARATOR - stainless steel SHAFTS AND BOLTS - stainless steel SADDLE - stainless steel (4" - cast iron) LUG STRIPS - stainless steel U-STRAPS - stainless steel
OPTIONAL EQUIPMENT	Totalizer Extensions and a wide range of controls and instruments for indicating, totalizing and recording flow data for each meter. Special constructions and materials are available upon request.
ORDERING INFO	Must be specified by the customer and includes: Minimum and maximum flow ranges, pipe I.D. and O.D. or wall thickness, 20" O.D. maximum (Consult factory for larger diameters). [4" meter for 4.5" O.D. only], position of meter (vertical, horizontal, or inclined), temperature of meter environment, totalizer dial units, type of materials and construction, and optional equipment desired.

MODEL LP31

150 psi STRAP-ON SADDLE METER
 SEALED METER MECHANISM - MAGNETIC DRIVE
 STAINLESS STEEL STRAP-ON SADDLE
 SEALED TOTALIZER
 SIZES 4" thru 20"

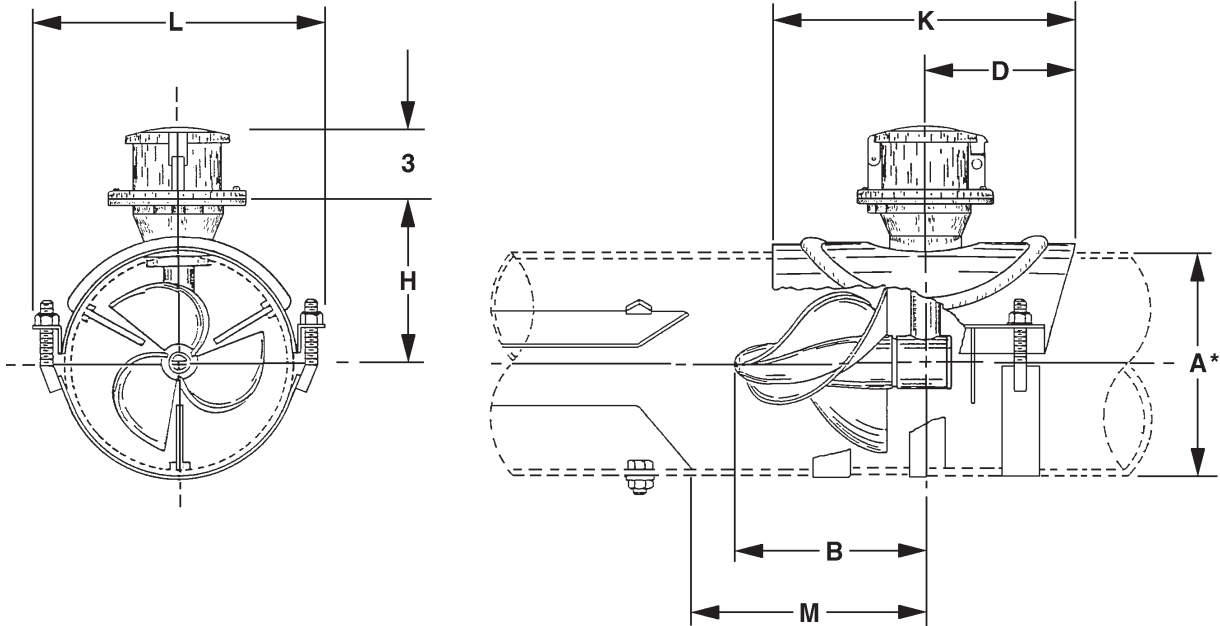

* PLEASE SPECIFY PIPE I.D. AND O.D.

‡ 4" METER MUST BE 4.5" O.D. FOR PROPER SEALING OF THE SADDLE

METER & PIPE SIZE	FLOW RANGES, GPM			DIMENSIONS						SHIPPING WEIGHT POUNDS	
	MIN.	MAX.	INT.	A	B	D	H	K	L		
4	80	500	700	4½ ‡	8	3 ³ / ₁₆	2 ⁷ / ₈	7 ⁷ / ₈	8½	10	18
6	200	1200	1500	6 ⁵ / ₈	8	6	5¼	12	13	10	20
8	250	1500	2000	8 ⁵ / ₈	8	6	6¼	12	12½	10	25
10	300	2000	3000	10¾	8	6	7 ³ / ₈	12	13¾	10	28
12	350	3000	3500	12¾	8	6	8 ³ / ₈	12	15¼	10	32
14	450	4000	4500	14	8	6	9¼	12	15½	10	35
16	500	5000	6000	16	8	6	10¼	12	17½	10	38
18	800	6000	7500	18	8	6	11¼	12	19½	10	43
20	950	8000	9000	20	8	6	12¼	12	21½	10	49



www.mccrometer.com

3255 WEST STETSON AVENUE • HEMET, CALIFORNIA 92545 USA
 TEL: 951-652-6811 • FAX: 951-652-3078

Copyright © 2019 McCrometer. All printed material should not be changed or altered without permission of McCrometer. The published technical data and instructions are subject to change without notice. Contact your McCrometer representative for current technical data and instructions.