



BALANCED PRESSURE THERMOSTATIC STEAM TRAP

MODELS L21S/L32S

BALANCED PRESSURE THERMOSTATIC TRAP WITH "FAIL OPEN" DESIGN

Benefits

Inline repairable steel-bodied traps with high air venting capability and light to medium condensate capacity for tracing and process equipment.

1. Patented "fail open" design for critical service.
2. Hardened stainless steel valve head and seat for maximum longevity.
3. Positive open-close operation reduces valve wear.
4. "Pressure-to-close" valve design improves life.
5. Valve, multiple diaphragms and casing have matching contours for high superheat capability and water hammer resistance.
6. Built-in screen promotes trouble-free service.
7. Self-draining for freeze protection in vertical use.
8. Flat mirror-finish valve head provides tightest sealing for energy efficiency and life.
9. Compact and capable of self adjusting to wide flow.
10. Easily cleanable and repairable design lowers maintenance costs.
11. Model L32SC with built-in check valve is available upon request.

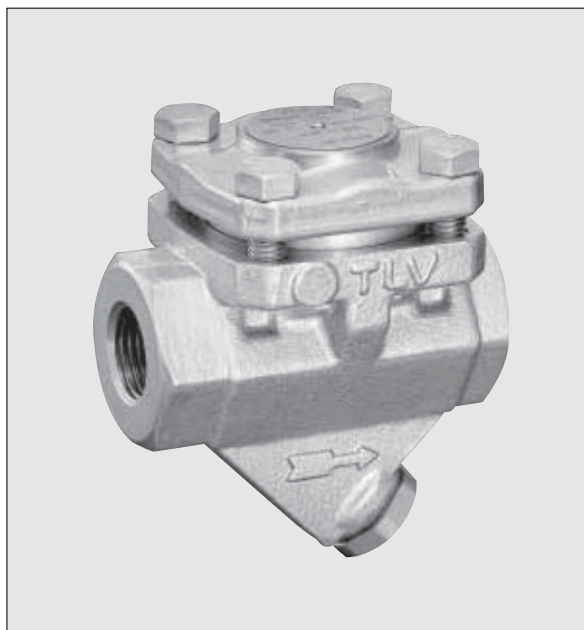

Specifications

Model	L21S		L32S	
Connection	Screwed	Socket Weld	Screwed	Socket Weld
Size (in)	1/2, 3/4, 1			
Max. Operating Pressure (psig) PMO	300		450	
Min. Operating Pressure (psig)	Vacuum			
Maximum Back Pressure	90% of Inlet Pressure			
Max. Operating Temp (°F) TMO	see graph at right			
Max. Allowable Pressure (°F) PMA	450			
Max. Allowable Temperature (°F) TMA	572			
Subcooling of X-element Fill (°F)	up to 11 (option : up to 40)			
Type of X-element	C6 (option : C22)			
Number of Diaphragms	4			

Connections and sizes in bold are standard



To avoid abnormal operation, accidents or serious injury, DO NOT use this product outside of the specification range. Local regulations may restrict the use of this product to below the conditions quoted.

No.	Description	Material	ASTM/AISI*	JIS
①	Body	Carbon Steel	A105	—
②	Cover	Carbon Steel	A105	—
③ ^R	X-element	Stainless Steel	—	—
④ ^R	Screen	Stainless Steel	AISI430	SUS430
⑤ ^{MR}	Screen Holder Gasket	Soft Iron	AISI1010	SUYP
⑥	Screen Holder	Carbon Steel	A105	—
⑦ ^R	Valve Seat	Stainless Steel	AISI420F	SUS420F
⑧ ^R	X-element Guide	Stainless Steel	AISI304	SUS304
⑨ ^R	Spring Clip	Stainless Steel	AISI304	SUS304
⑩ ^{MR}	Cover Gasket	Graphite/Stainless Steel	— / AISI316L	— / SUS316L
⑪	Cover Bolt	Carbon Steel	AISI1045	S45C
⑫	Nameplate	Stainless Steel	AISI304	SUS304
⑬ ^R	Check Valve Ball	Stainless Steel	AISI440C	SUS440C
⑭	BD2 Blowdown Valve**	Cast Stainless Steel	A351 Gr.CF8	—

* Equivalent ** Option

Replacement kits available: (M) maintenance parts, (R) repair parts

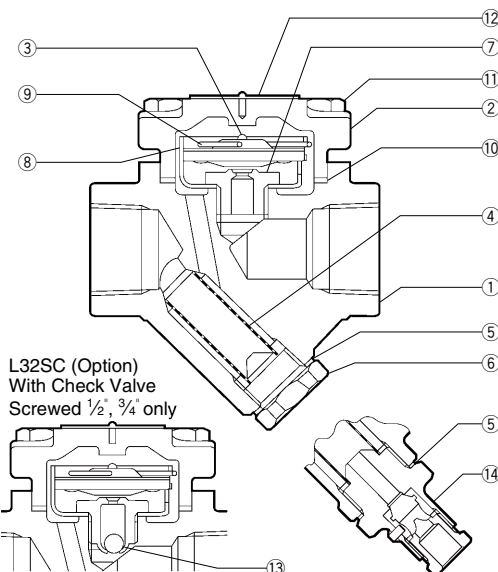
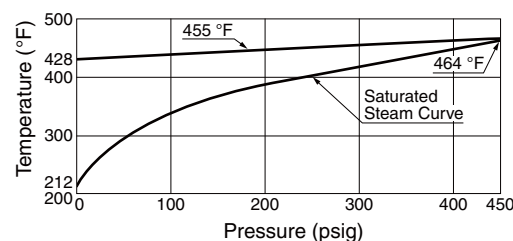

Copyright © TLV

Dimensions

● **L21S/L32S** Screwed

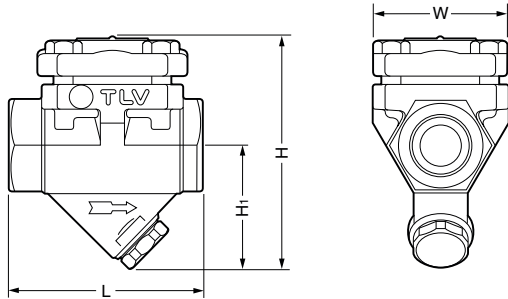

L21S/L32S Screwed* (in)

Size	L	H**	H ₁ **	W	Weight (lb)
1/2	3 1/8	3 13/16	2	1 7/16	2.9
3/4					
1	3 7/16	4 1/8	2 3/16	1 3/4	4.0

* NPT, other standards available
 ** With optional BD2 add approx. 1 1/16" to H and H₁.

The optional model L32SC with internal check valve has the same dimensions and weights as model L32S.

● **L21S/L32S** Socket Weld

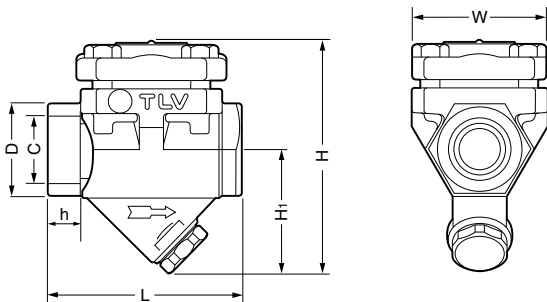

L21S/L32S Socket Weld* (in)

Size	L	H**	H ₁ **	W	φD	φC	h	Weight (lb)
1/2	3 1/8	3 13/16	2	1 7/16	1 3/16	0.855	1/2	2.9
3/4					1 7/16	1.065		
1	3 7/16	4 1/8	2 3/16	1 3/4	1 3/4	1.330	9/16	4.0

* ASME B16.11-2005, other standards available
 ** With optional BD2 add approx. 1 1/16" to H and H₁.

Discharge Capacity

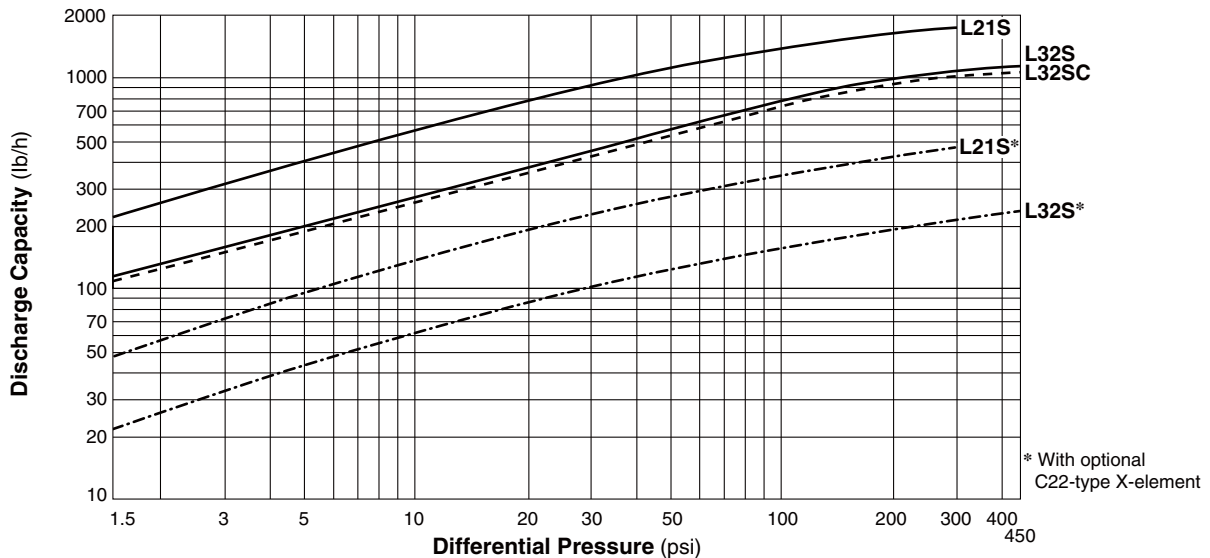

1. Differential pressure is the difference between the inlet and outlet pressure of the trap.
2. Recommended safety factor: at least 2.



CAUTION DO NOT DISASSEMBLE OR REMOVE THIS PRODUCT WHILE IT IS UNDER PRESSURE. Allow internal pressure of this product to equal atmospheric pressure and its surface to cool to room temperature before disassembling or removing. Failure to do so could cause burns or other injury. READ INSTRUCTION MANUAL CAREFULLY.

TLV CORPORATION

13901 South Lakes Drive, Charlotte, NC 28273-6790
 Tel: 704-597-9070 Fax: 704-583-1610
 E-mail: tlv@tlvengineering.com <https://www.tlv.com>
 For Technical Service 1-800 "TLV TRAP"



Manufacturer
TLV CO., LTD.
 Kakogawa, Japan
 is approved by LRQA Ltd. to ISO 9001/14001

