



FREE FLOAT[®] AIR TRAP

MODEL JA7

FREE FLOAT COMPRESSED AIR TRAP

Benefits

Extremely durable, inline-repairable free float trap with a large capacity for automatic drainage of condensate and oil from compressed-air systems.

1. Self-modulating free float provides continuous, smooth, low velocity condensate discharge as process loads vary, for maximum performance.
2. Durable valve seat maintains air-tight seal, even under low-load conditions.
3. Unique rotational seating design prevents concentrated wear to provide long maintenance-free service life.
4. External manual plunger unit allows rapid cleaning of the valve seat during operation, in the event of oil or dirt accumulation.
5. Rugged float construction with up to 1500 psig hydraulic shock rating ensures excellent performance of the trap.
6. Easy, inline access to internal parts simplifies cleaning and lowers maintenance costs.
7. Built-in screen with large surface area ensures extended trouble-free service.



Specifications

Model	JA7	
Connection	Flanged	
Size (in)	1, 1½, 2	
Orifice No.	16	
Maximum Operating Pressure (psig)	PMO	230
Maximum Differential Pressure (psi)	ΔPMX	230
Minimum Operating Pressure (psig)	Vacuum	
Maximum Operating Temperature (°F)	TMO	212
Maximum Allowable Pressure (psig)	PMA	250
Maximum Allowable Temperature (°F)	TMA	428
Applicable Fluid*	Air	

* Do not use for toxic, flammable or otherwise hazardous fluids.

JA7 is a non-standard product, consult TLV for delivery time required.

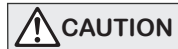

To avoid abnormal operation, accidents or serious injury, DO NOT use this product outside of the specification range. Local regulations may restrict the use of this product to below the conditions quoted.

No.	Description	Material	ASTM/AISI*	JIS
①	Body	Cast Iron	A842 Gr.400	FCV400
②	Cover	Cast Iron	A842 Gr.400	FCV400
③ ^F	Float	Stainless Steel	AISI316L	SUS316L
④ ^{MR}	Holder Nut Gasket	Fluorine Resin	PTFE	PTFE
⑤ ^{MR}	Valve Seat Holder O-Ring	Nitrile Rubber	D2000BF	NBR
⑥ ^R	Valve Seat	Nitrile Rubber	D2000BF	NBR
⑦	Nameplate	Stainless Steel	AISI304	SUS304
⑧ ^R	Valve Seat Holder Nut	Stainless Steel	AISI420F	SUS420F
⑨ ^{MR}	Cover Gasket	Fluorine Resin	PTFE	PTFE
⑩	Cover Bolt	Carbon Steel	AISI1045	S45C
⑪	Balancing Line Plug	Carbon Steel	A6	SS400
⑫	Snap Ring	Stainless Steel	AISI304	SUS304
⑬ ^R	Screen	Stainless Steel	AISI430	SUS430
⑭	Screen Holder	Stainless Steel	AISI304	SUS304
⑮	Screen Holder Retainer	Stainless Steel	AISI304	SUS304
⑯ ^R	Snap Ring	Stainless Steel	AISI304	SUS304
⑰ ^R	Needle	Stainless Steel	AISI420F	SUS420F
⑱ ^{MR}	Needle O-Ring	Nitrile Rubber	D2000BF	NBR
⑲ ^R	Coil Spring	Stainless Steel	AISI304	SUS304
⑳ ^R	Split Pin	Stainless Steel	AISI403	SUS304
㉑ ^R	Plunger	Stainless Steel	AISI420F	SUS420F
㉒ ^R	Guard Bushing	Synthetic Resin	—	—
㉓ ^R	Valve Seat Holder	Stainless Steel	AISI420F	SUS420F
㉔ ^R	Washer	Stainless Steel	AISI304	SUS304
㉕	Drain Plug	Carbon Steel	A6	SS400

* Equivalent

Replacement kits available: (M) maintenance parts, (R) repair parts, (F) float

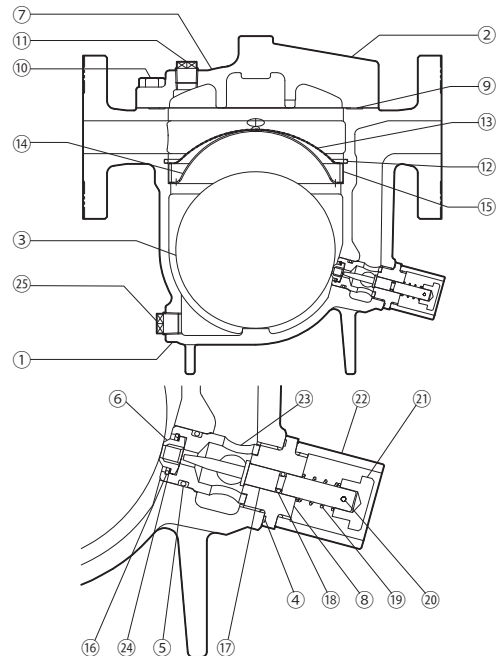

Dimensions

• **JA7** Flanged

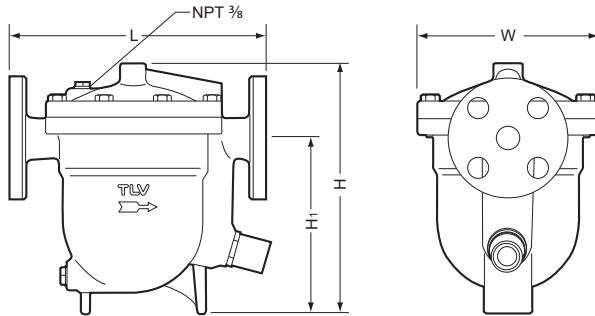

JA7 Flanged (in)

Size	L		H	H ₁	W	Weight* (lb)
	Connects to ASME Class 125FF	250RF				
1	10 3/16	10 5/8	10 1/4	7 3/16	7 5/16	34
1 1/2	10 5/8	11 1/8	10 13/16	7 1/2		39
2	11 1/8	11 5/8	11 1/4	7 11/16		41

Other standards available, but length and weight may vary
* Weight is for Class 250 RF.

NOTE:
A pressure-balancing line must be connected to the air system from the balancing port at the top of the trap to a place above any possible condensate accumulation in the system.

Discharge Capacity

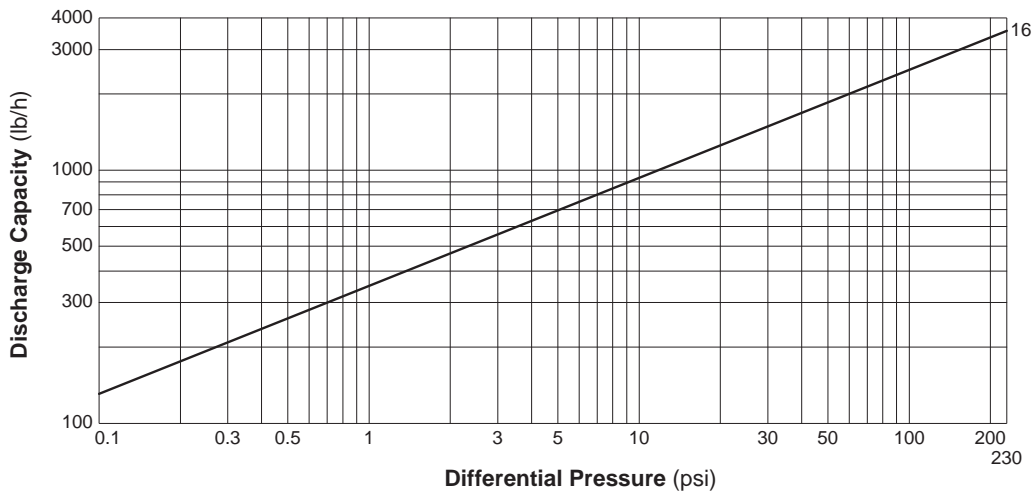

1. Line numbers within the graph refer to orifice numbers.
2. Differential pressure is the difference between the inlet and outlet pressure of the trap.
3. The chart is applicable to condensate below 212°F.
4. The discharge capacity is for a liquid with specific gravity of 1.
5. Recommended safety factor: at least 1.5.

CAUTION DO NOT use this product under conditions that exceed maximum differential pressure, as condensate backup will occur!

CAUTION DO NOT DISASSEMBLE OR REMOVE THIS PRODUCT WHILE IT IS UNDER PRESSURE. Allow internal pressure of this product to equal atmospheric pressure and its surface to cool to room temperature before disassembling or removing. Failure to do so could cause burns or other injury. READ INSTRUCTION MANUAL CAREFULLY.

TLV CORPORATION

13901 South Lakes Drive, Charlotte, NC 28273-6790
Tel: 704-597-9070 Fax: 704-583-1610
E-mail: tlv@tlvengineering.com <https://www.tlv.com>
For Technical Service 1-800 "TLV TRAP"



Manufacturer
TLV CO., LTD.
Kakogawa, Japan
is approved by LRQA Ltd. to ISO 9001/14001

