



# FREE FLOAT® STEAM TRAP

## MODEL JH7RL-X JH7RL-B/JH7RM-B

### FREE FLOAT STEAM TRAP WITH THERMOSTATIC AIR VENTING

#### Benefits

A reliable and durable cast steel steam trap for use on medium-size process equipment. JH7RL-B/JH7RM-B are also suitable for both superheated and high-pressure process equipment.

1. Self-modulating free float provides continuous, smooth, low-velocity condensate discharge as process loads vary.
2. Precision-ground float, constant water seal and three-point seating design ensure a steam-tight seal, even under no-load conditions.
3. Rugged float construction with up to 1500 or 2300 psig\* hydraulic shock rating ensures excellent resistance to water hammer.
4. **JH7RL-X**: Thermostatic capsule (X-element) with "fail open" feature vents air automatically at close-to-steam temperature.
5. **JH7RL-B/JH7RM-B**: Thermostatic bimetal air vent valve vents air automatically for rapid startup.
6. Built-in screen with large surface area ensures extended trouble-free operation.
7. Easy, inline access to internal parts simplifies cleaning and reduces maintenance costs.

\* Depending on orifice No.



#### Specifications

Model	JH7RL-X			JH7RL-B		JH7RM-B	
	Screwed	Socket Weld	Flanged	Socket Weld	Flanged	Socket Weld	Flanged
Connection							
Size (in)	1, 1½	¾, 1, 1½, 2	¾, 1, 1½, 2	1, 1½, 2	1, 1½, 2	¾, 1, 1½, 2	1, 1½, 2
Orifice No.		2, 5, 10, 14, 22, 32		2, 5, 10, 14, 22, 32, 40, 46			65
Maximum Operating Pressure (psig) PMO		30, 75, 150, 200, 315, 450		30, 75, 150, 200, 315, 450, 600, 650			925
Maximum Differential Pressure (psi) Δ PMX		30, 75, 150, 200, 315, 450		30, 75, 150, 200, 315, 450, 600, 650			925
Minimum Operating Pressure (psig)		Vacuum		1.5			1.5
Maximum Operating Temperature (°F) TMO		464		800			800
Maximum Allowable Pressure (psig) PMA		600		650			925
Maximum Allowable Temperature (°F) TMA		800		800			800
Type of Air Vent		X-element (11 °F subcooling)		Bimetal (vents air up to approx. 212 °F)			

No.	Description	Material	ASTM/AISI*	JIS
①	Body	Cast Steel	A216 Gr.WCB	—
②	Cover	Carbon Steel	A105	—
③ <sup>F</sup>	Float	Stainless Steel	AISI316L	SUS316L
④ <sup>R</sup>	Orifice	—	—	—
⑤ <sup>MR</sup>	Orifice Gasket	Soft Iron	AISI1010	SUYP
⑥	Orifice Plug	Cast Stainless Steel	A351 Gr.CF8	—
⑦ <sup>MR</sup>	Orifice Plug Gasket	Soft Iron	AISI1010	SUYP
⑧	Screen Holder	Stainless Steel	AISI304	SUS304
⑨ <sup>R</sup>	Screen	Stainless Steel	AISI430	SUS430
⑩	Socket**/Flange	Carbon Steel	A105	—
⑪	Cover Bolt	Alloy Steel	A193 Gr.B7	SNB7
⑫	Cover Nut	Carbon Steel	AISI1045	S45C
⑬ <sup>MR</sup>	Cover Gasket	Graphite/Stainless Steel	—/AISI316L	—/SUS316L
⑭	Connector	Stainless Steel	AISI416	SUS416
⑮ <sup>MR</sup>	Connector Gasket	Graphite/Stainless Steel	—/AISI316L	—/SUS316L
⑯ <sup>R</sup>	X-element Guide	Stainless Steel	AISI304	SUS304
⑰ <sup>R</sup>	X-element	Stainless Steel	—	—
⑱ <sup>R</sup>	Spring Clip	Stainless Steel	AISI304	SUS304
⑲ <sup>R</sup>	Air Vent Valve Seat	Stainless Steel	AISI420F	SUS420F
⑳ <sup>R</sup>	Snap Ring	Stainless Steel	AISI304	SUS304
㉑ <sup>R</sup>	Air Vent Case	Cast Stainless Steel	A351 Gr.CF8	—
㉒ <sup>R</sup>	Bimetal Plate	Bimetal	—	—
㉓ <sup>R</sup>	Air Vent Screen	Stainless Steel	AISI304	SUS304
㉔ <sup>R</sup>	Air Vent Valve Seat	—	—	—
㉕ <sup>R</sup>	Air Vent Valve Plug	—	—	—
㉖ <sup>R</sup>	Snap Ring	Stainless Steel	AISI304	SUS304
㉗	Nameplate	Stainless Steel	AISI304	SUS304
㉘ <sup>MR</sup>	Drain Plug Gasket	Soft Iron	AISI1010	SUYP
㉙	Drain Plug	Carbon Steel	AISI1025	S25C

\* Equivalent \*\* Shown on reverse

Replacement kits available: (M) maintenance parts, (R) repair parts, (F) float



**Connections and sizes in bold are standard**  
To avoid abnormal operation, accidents or serious injury, DO NOT use this product outside of the specification range. Local regulations may restrict the use of this product to below the conditions quoted.

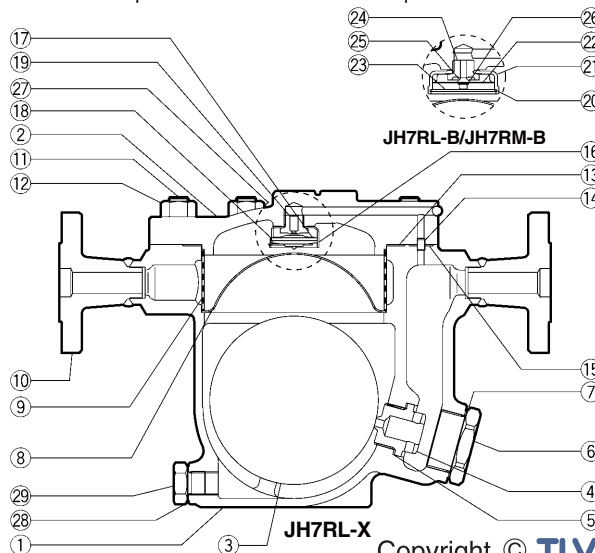

Copyright © TLV

**Dimensions**

● **JH7RL-X** Screwed

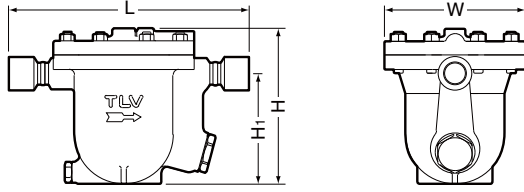

**JH7RL-X** Screwed\* (in)

Model	Size	L	H	H <sub>1</sub>	W	Weight (lb)
JH7RL-X	1	13 1/8	8 7/8	6 5/16	8 1/8	37
	1 1/2	13 1/4				42

\* NPT, other standards available

● **JH7RL-X/JH7RL-B/JH7RM-B** Socket Weld

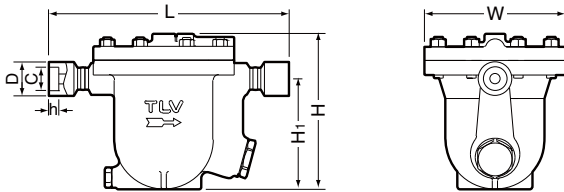

**JH7RL-X/JH7RL-B/JH7RM-B** Socket Weld\*(in)

Model	Size	L	H	H <sub>1</sub>	W	ΦD	ΦC	h	Weight (lb)
JH7RL-X	3/4**	12 11/16	8 7/8	6 5/16	8 1/8	1 5/8	1.065	9/16	37
	1	13 1/8				2	1.330		42
	1 1/2	13 1/4				2	1.915		44
JH7RM-B	3/4	12 11/16	9 1/8	6 5/16	8 3/4	1 9/16	1.065	9/16	42
	1	13 1/8				1 7/8	1.330		46
	1 1/2	13 1/4				2	1.915		48
	2	13 1/4				3 1/8	2.406		1 1/16

\* ASME B16.11-2005, other standards available

\*\* Not available for JH7RL-B

● **JH7RL-X/JH7RL-B/JH7RM-B** Flanged

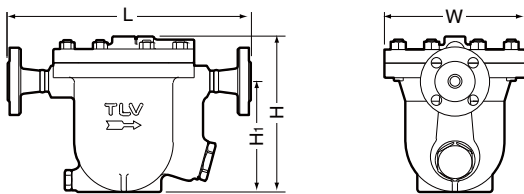

**JH7RL-X/JH7RL-B/JH7RM-B** Flanged (in)

Model	Size	L				H	H <sub>1</sub>	W	Weight*** (lb)
		Connects to ASME Class							
		150RF*	300RF*	600RF*	900RF*				
JH7RL-X	3/4**	13 3/8	13 3/8	13 3/8	—	8 7/8	6 5/16	8 1/8	46
	1	15 1/8	15 1/8	15 1/8	—				51
	JH7RL-B	1 1/2	15	15	15				—
JH7RM-B	2	15 3/8	15 3/8	15 3/8	—	9 1/8	6 5/16	8 3/4	66
	1	15 1/8	15 1/8	15 1/8	15 3/16				55
	1 1/2	15	15	15	15 3/8				64
	2	15 3/8	15 3/8	15 3/8	15 3/4				66

Other standards available, but length and weight may vary

\* Not standard for JH7RL-B/JH7RM-B \*\* Not available for JH7RL-B

\*\*\* Weight is for Class 600 RF

Flange classes in bold are standard

**Discharge Capacity**

● **JH7RL-X**

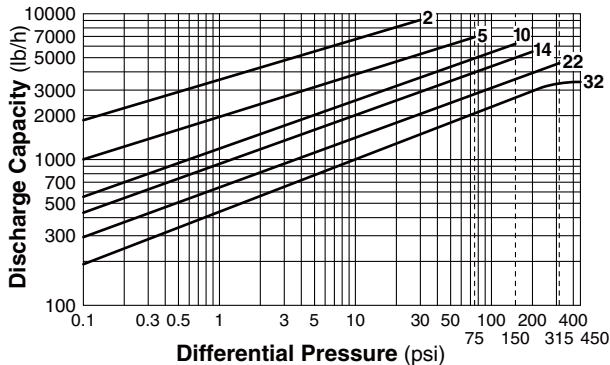

● **JH7RL-B/JH7RM-B**

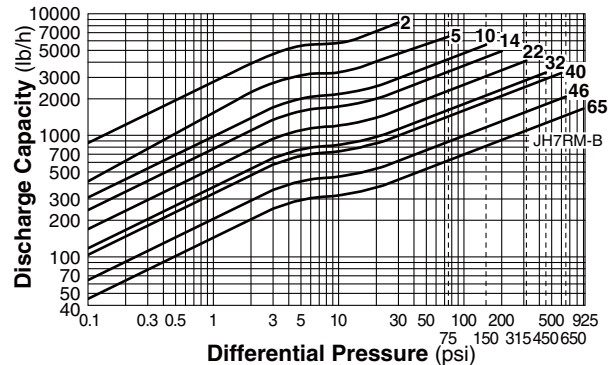

- Line numbers within the graph are orifice numbers.
- Differential pressure is the difference between the inlet and outlet pressure of the trap.
- Capacities are based on continuous discharge of condensate 11 °F below saturated temperature.
- Recommended safety factor: at least 1.5.

**CAUTION** DO NOT use this product under conditions that exceed maximum differential pressure, as condensate backup will occur!

**CAUTION** DO NOT DISASSEMBLE OR REMOVE THIS PRODUCT WHILE IT IS UNDER PRESSURE. Allow internal pressure of this product to equal atmospheric pressure and its surface to cool to room temperature before disassembling or removing. Failure to do so could cause burns or other injury. READ INSTRUCTION MANUAL CAREFULLY.

**TLV CORPORATION**

13901 South Lakes Drive, Charlotte, NC 28273-6790  
 Tel: 704-597-9070 Fax: 704-583-1610  
 E-mail: [tlv@tlvengineering.com](mailto:tlv@tlvengineering.com) <https://www.tlv.com>  
 For Technical Service 1-800 "TLV TRAP"



Manufacturer  
**TLV CO., LTD.**  
 Kagawa, Japan  
 is approved by LRAA Ltd. to ISO 9001/14001

