



bürkert
FLUID CONTROL SYSTEMS

Product Overview

Solenoid Valves

01

02 PROCESS VALVES

03 PNEUMATICS

04 MEASUREMENT DEVICES

05 MICROFLUIDICS

06 MASS FLOW CONTROLLERS

07 PROPORTIONAL VALVES

Solenoid valves – Switching to make things move

Bürkert stands for quality and competence in the sector of fluid technology. Our products are used wherever fluids and gases need to be measured, controlled and regulated.

Bürkert has been developing and producing solenoid valves for more than 70 years. In doing so we use recognised technical principles and unique technologies with a common goal: to fulfil your requirements.

We customise our valves to fit your applications and therefore offer you the optimal solution for your needs. That is why Bürkert valves can be found in virtually every industry.

From welding robots to waterworks, from dust removal in mining operations to cabin pressure control in aircraft – everything is possible with our valves as a reliable component in your system. Whether you need a single valve, valve blocks or customised solutions, our entire product line is oriented toward ensuring controlled handling of liquids and gases.

Our products are therefore designed in accordance with the following requirements:

- High flexibility due to modular design
- Diverse choice of materials
- High reliability
- Long service life
- Low environmental impact

This overview, as a supplement to our specific product brochures and detailed data sheets at www.buerkert.de, will facilitate your search for suitable products.

Our employees will be glad to assist you in selecting the right product.

Content

- 3 Introduction
- 4 Fascination Bürkert
- 6 Solenoid valves from a single source
- 8 Sectors / industries
- 9 Certifications and certificates
- 10 Fluid Fascination
- 12 Circuit symbols
- 13 Body connections
- 14 Typical pressure profile
- 16 Coil technology
- 20 Direct Acting Valves
- 36 Servo Assisted Valves
- 48 Materials of Construction
- 50 Selection Chart Solenoid Valves
- 52 Selection Chart Micro Fluidics
- 54 System Solutions
- 58 Service Promise
- 59 Contacts at Bürkert

Welcome to the Fascinating World of Fluid Control Systems

Measurement and control: When it comes to working with liquids and gases, we are at your side – as a manufacturer of sophisticated products, as a problem-solver with an eye for the big picture, and as a partner offering you reliable advice. Since we started in 1946, we have developed into one of the world's leading suppliers of Fluid Control Systems. At the same time we have kept our status as a family-owned business with a foundation of strong basic values to highlight the way we think and act.

EXPERIENCE

There are things which are not inherently yours. You have to gather them bit by bit. You receive them from others. And you constantly have to acquire them anew. That is what makes them so valuable. Experience is one of those things. For instance, because of our many years of design and manufacturing experience, we can provide our extensive services to you – from consulting, development, and 3D CAD simulating to testing and after-sales service. Whether individual product solutions or a pioneering new system for the entire control process: Benefit from our experience.

COURAGE

Those who only work toward optimizing things that already exist will eventually reach the limits – technically, financially, or personally. In order to overcome these limits, courage is needed: The courage to be different and trust one's own ideas; the courage to venture into the unknown, searching for new ways to develop products that have never existed before. We have this courage. By pooling and utilizing our competencies across all sectors, you benefit from our cumulative process solenoid knowledge – whether it is in your latest blockbuster machine or the deepest part of your factory.

CLOSENESS

There are things we simply take for granted. Only when they are gone, do we realize how important these things really were. This applies in particular to closeness. Without closeness, it is very difficult to build relationships and a good understanding of one another. As an established medium-sized company, we know that. And that is why we are always there for you. Working with you, we develop the best possible solutions for your projects in all areas of solenoid valves. Our global presence in 35 locations enables us to press ahead with technical innovations for our customers around the world.

Bürkert Product Program

We are one of the few suppliers on the market to cover the complete control loop. Our current product range extends from solenoid valves through process and analytical valves to pneumatic actuators and sensors.

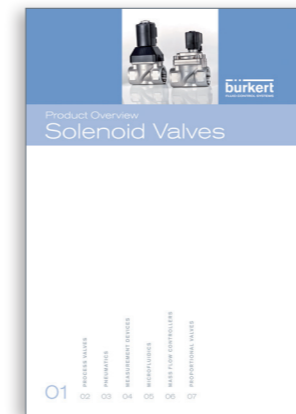

Bürkert offers a remarkable range of servo assisted and direct acting solenoid valves. Read more about them in this brochure.

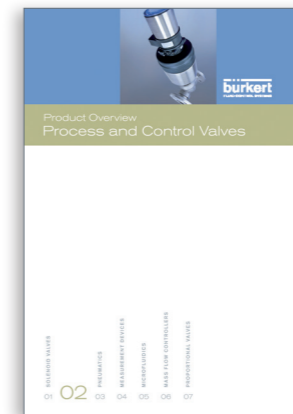

Bürkert offers unlimited modularity for process control with angle-seat, globe and diaphragm valves in the widest range of configurations.



Here you can find our product range of pneumatic valves, valve units and automation systems as well as information on our control cabinet building.



Here you can find our sensors, transmitters and controllers for measuring and controlling flow, temperature, pressure, level, pH/ORP and conductivity.

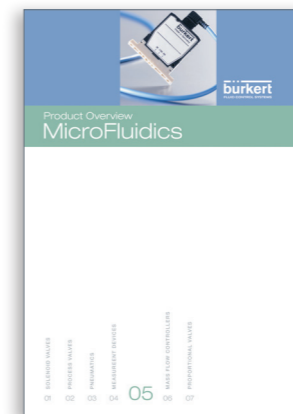

The brochure contains an overview of Bürkert miniature valves and micro pumps, which allow for precise and safe handling of small volumes of liquids.

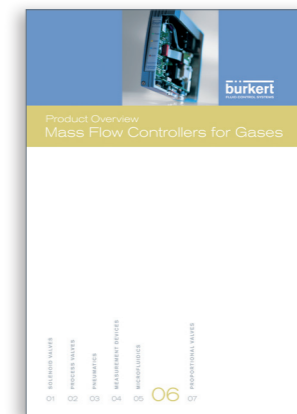

This brochure provides technical background information as well as a detailed product overview for the mass flow controller and meter product range.

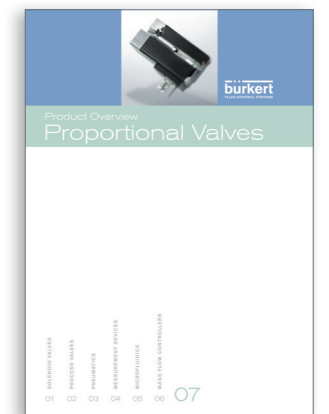

This brochure presents our solenoid control valves including their respective features, functions and typical applications.



Solenoid valves from a single source

Range of manufacture with know-how

We offer you a complete performance spectrum. Everything from choosing the right product to consulting, engineering, production and commissioning.

Take advantage of our competence in production and development. Our qualified engineers work continuously on the optimisation of fluid technology. Our high degree of vertical diversification allows us to respond to special customer requirements and to produce components quickly and independently.

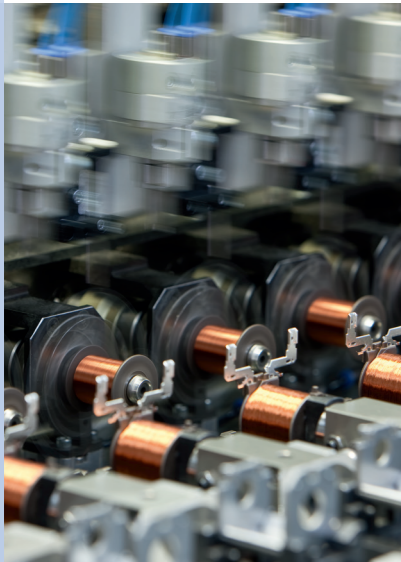

COIL MANUFACTURE

At the Gerabronn factory.

We wind, mould and inspect our coils ourselves. This independence ensures complete quality control and traceability of the solenoid valve production. Our coiling machines are capable of winding wires that are hardly thicker than a human hair. The length of a coil winding can be as long as 4 km. The materials for the moulding vary corresponding to the capacity and the required chemical resistance. Every production step is followed by an automatic function check of all coils.

Our high vertical diversification enables the manufacture of customised coils to match the capacity and voltage requirements of your valve.



MECHANICAL PRODUCTION

Machining of metals and plastics at the Criesbach factory.

Our in-house machining technologies include:

- Milling
- Forming
- Welding
- Turning
- Injection moulding

Medical and analysis technology require high processing standards. We fulfil the different requirements for surface quality and media resistance by using suitable materials. Complex, customised forms are achieved in our in-house plastic injection moulding system. The machine park and in-house tool manufacturing department allow the manufacture of complex geometries. Our vertical diversification reduces production times and allows us to remain flexible for your application.

GUARANTEED QUALITY

Comprehensive inspections and tests ensure the quality of our products.

To fulfil your requirements we conduct numerous tests prior to starting serial production. International standards and directives are checked separately. Our UL lab, for example, is accredited as a test facility since 2014 and we have achieved "Category Certification Status" from CSA.

Once the requirements are fulfilled and the approvals are granted, valve production can begin. Our series start-up management provides for a smooth start-up of the production process. Not only our coils, but also the assembled valves go through a 100 % function check. Every valve delivered is tested and checked both electrically and mechanically. Nothing is left to chance.



DUST-FREE ENVIRONMENT

Special workplaces ensure clean assembly of miniaturised valves.

To guarantee the high quality and functionality of our products, valve assembly for sensitive applications takes place in a virtually dust-free environment. Filter systems in separate rooms minimise the particle concentration to ensure proper functioning of sensitive valves. Some parts not only have to be dust-free, but also free of oils and greases. Special workplaces and cleaning processes make it possible to fulfil these hygiene conditions for our smallest valves.



COMPETENT CONSULTING

We can adapt everything to your needs, whether for a single valve or a special application.

We offer an extensive line of products that can be combined in many different ways. Together with you, thanks to many years of experience and the necessary know-how, we will find the right components and the optimal valve solution. Perfect coordination of all areas is your guarantee for the quality of our products.

In addition to our product line we also offer you comprehensive service to boost the performance of your processes.



Sectors / industries

Bürkert solenoid valves can be found in many different sectors. Several examples are listed here. Your sector is most likely included. If not, our competent sales representatives will be glad to assist you.

Sectors	Example application
Water supply	Treatment of drinking water
Waste water treatment	Purification / treatment of grey and black water
Machine and plant engineering	Cooling, lubrication and dosing
Building services	Large heating systems, climate control
Safety engineering	Water mains protection and fire extinguishing systems
Compressors	Pressure relief and drainage
Fuel supply	Transport and tank facilities
Firing systems	Oil and gas burner control
Gas chromatography	Gas mixture regulation
Blood analysis instruments	Control of cleaning processes
Sterilisers	Control of steam sterilisation
General process engineering	Mixing processes
Textile industry	Ironing machines, dyeing and washing systems
Domestic installations	Heating and sanitary technology
Biogas plants	Gas and heat control
Shipbuilding	Control of diesel and auxiliary fuels, separator technology
Rail and motor vehicle construction	Emptying and filling, pneumatic door controls
Car washes	Water and cleaning agent dosing



Certifications and certificates

Different certifications and certificates are available depending on the applications and the regional utilisation of the valves. The following table gives an overview of the available certifications and certificates.

Certifications			Certificates
UL	Watermark	ATEX	Oxygen suitability
UR	DVGW Gas EN 161	IEC EX	3.1 Material certification
CSA	KTW W270	KOSHA	Biocompatibility
Hazloc	VDE	NEPSI	
	DNV GL		



Fluid Fascination

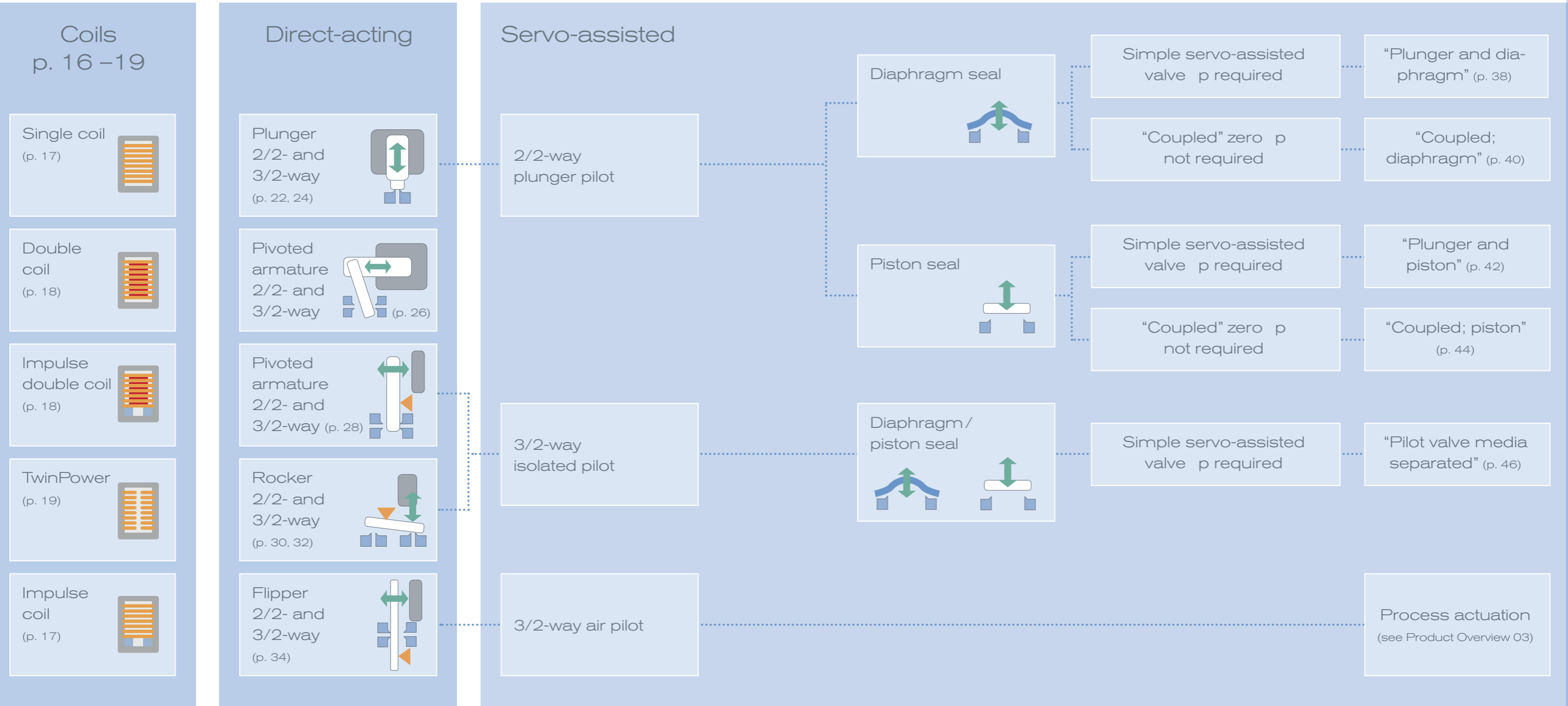

Circuit symbols

WW	Circuit symbol	Circuit function
A		2/2-way valve; normally closed
A		Servo-assisted 2/2-way valve; normally closed, pilot channel inside
B		2/2-way valve; normally open
B		Servo-assisted 2/2-way valve; normally open, pilot channel inside
C		3/2-way valve; normally closed, outlet A relieved
C		Servo-assisted 3/2-way valve; outlet A normally relieved, pilot channel inside
D		3/2-way valve; outlet B normally pressurized
D		3/2-way valve; outlet B normally pressurized, pilot channel inside
E		3/2-way mixer valve; normally pressure port P2 connected to outlet A, P1 closed
F		3/2-way distributor valve; normally pressure port P connected to outlet B
T		3/2-way valve; universally usable

WW = Circuit function

Body Connections

We build a vast array of valves for a dispersed and diverse global process control market. Regional and industry based requirements are taken care of by our internal modular simplicity. No matter where you are in the world and which industry norm you are trying to meet, we have your connection.

Type	Norms available
Threads	ISO, NPT, RC
Solvent weld	ISO
Welded	DIN
Flange	DIN, SFB

Plastics		Metals	
Solvent weld		Thread	
SFB*		Weld	
Push-in-Connection		Flange	
Hose fitting		SFB*	

* Specific flange Bürkert

Typical pressure profile for opening and closing processes

Opening and closing of a valve always has a temporary dynamic effect on the pressure conditions within a control system. The level of the change in pressure amplitude depends to a large degree on these physical parameters: static system pressure, hydrostatic pressure, pipe diameter, temperature, mass of the medium and the opening and closing response of the valve. While much is known about the physical facts, the opening and closing response of a valve is a variable that can hardly be calculated. However, the effects of excessive pressure amplitudes (pressure impacts) within a system can be serious. Noises and vibrating pipes are the most harmless effect. Pressure impacts can be as high as 36 times the rated pressure, resulting in damage to measurement hardware, pipes or shut-off valves. The required system availability can be increased by soft stop valves with a reduced pressure amplitude during closing. Bürkert takes this into account in the fluidic design of the internal valve construction.

Vacuum impact

A suction impact occurs during fast opening of a valve. Due to mass inertia, there is a delay in the yield force build-up. The pressure can drop all the way to 0 bar. The suction impact causes fewer noises and hardly affects the system, since it is never higher than the actual operating or static pressure.

Pressure impact

Fast closing of a valve causes a pressure surge, since the fluid is abruptly stopped. This results in pressure changes. The pressure rise can be as high as several times the operating pressure, causing excess load on the system. Especially measuring instruments such as pressure sensors are sensitive to pressure impacts. The optimised geometry of our valves, which are tested in our labs, ensures soft stop operation to protect your system without restricting the flow rate.

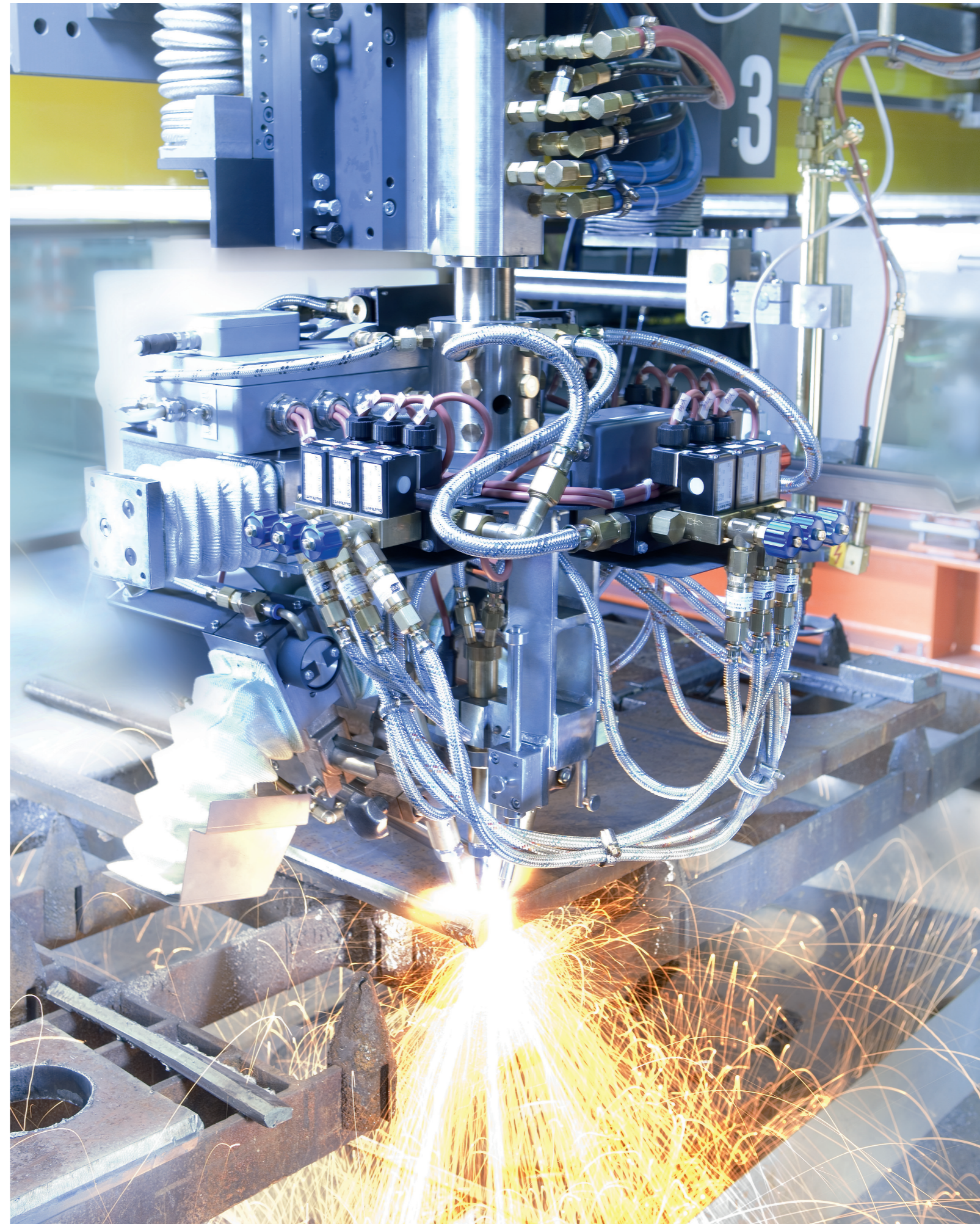
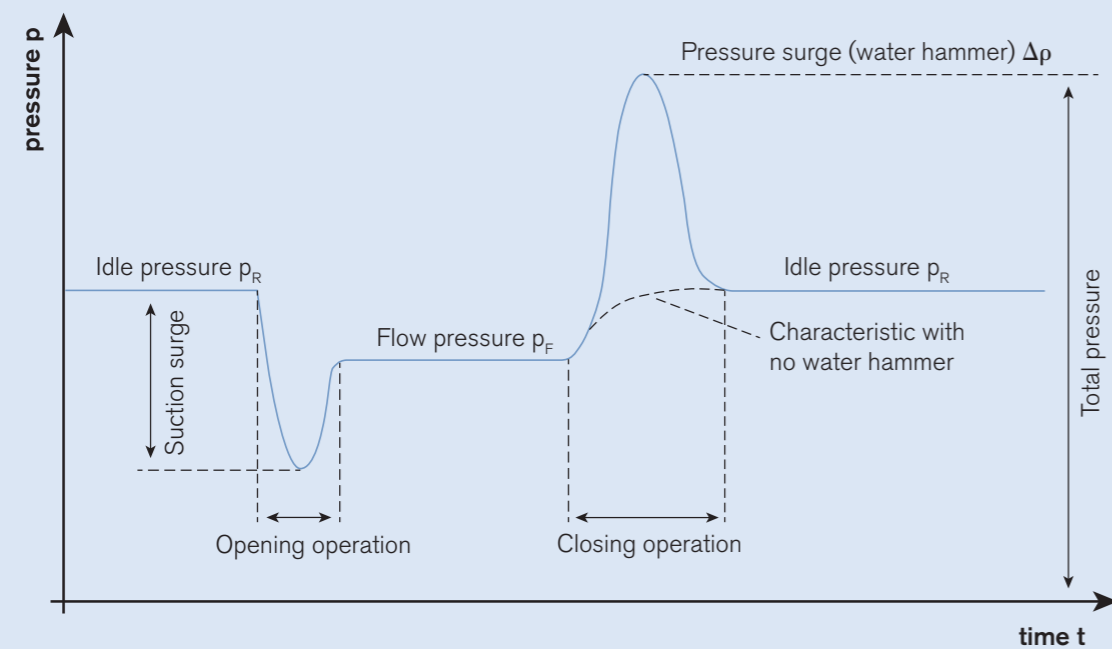

Coil technology

Solenoids have been in use for decades as simple, reliable and cost-effective valve actuators. Their function is to move the armatures or plungers in the valves without contact. Corresponding to the existing mains voltages, they are designed as DC or AC coils. Coils are also available with a frequency of 50 Hz and 60 Hz. The latter are used in solutions for the North American market.

Increased performance through electronics

Pulse width modulation (PWM)

In the starting moment the coil needs a high force, since it has to overcome the force of the closing spring and the valve lift (gap between armature and plunger). The more the gap is reduced by the motion of the armature, the higher the excess force. This excess force is dissipated into the environment as heat and costs valuable energy. Pulse width modulation is used to prevent this effect. After a short operating time the coil is supplied only with a pulsed direct current that is just sufficient for the valve to remain in switched state. This saves energy and protects the coil from overheating.

Overexcitation of a coil

The magnetic flux (ϕ phi) and therefore the force of a coil is proportional to the current flowing within the coil. In the case of overexcitation the coil is temporarily energised beyond its continuous load limit. This causes an extreme increase in the magnetic field and of the force. The force is then often sufficient to switch twice the nominal pressure or twice the nominal diameter. Electronics ensure that the temporary overexcitation lasts no longer than 500 ms, to prevent damage to the coil. The switching cycles are between 6 and 10 switching processes per minute.

Difference between DC and AC coils

DC and AC coils differ based on the frequency influence in the power data and in the response.

DC coil

- No buzzing
- No shading ring required
- Lower starting force than AC coil
- Lower switching pressure

AC coil

- Valve tends to buzz
- Shading ring required
- Higher starting force than DC coil
- High switching frequency causes higher temperature rise
- A mechanically blocked plunger can result in overheating and failure



Single magnetic coils

Construction:

An enamelled copper wire wound on a coil form is the simplest of all coil types. Bürkert coils are always coated with an insulating mass to ensure high electrical and mechanical protection. Corresponding to the required power (force) and frequency the coils are wound with wires of different thickness and the number of turns also varies. The coils are designed for continuous operation (100 % duty time).

Application:

90 % of all solenoid valves are equipped with single coils.

Special features:

In addition to the conventional enamelled copper wire, anodised enamelled copper wires are also used for high temperatures up to 250 °C ambient temperature.

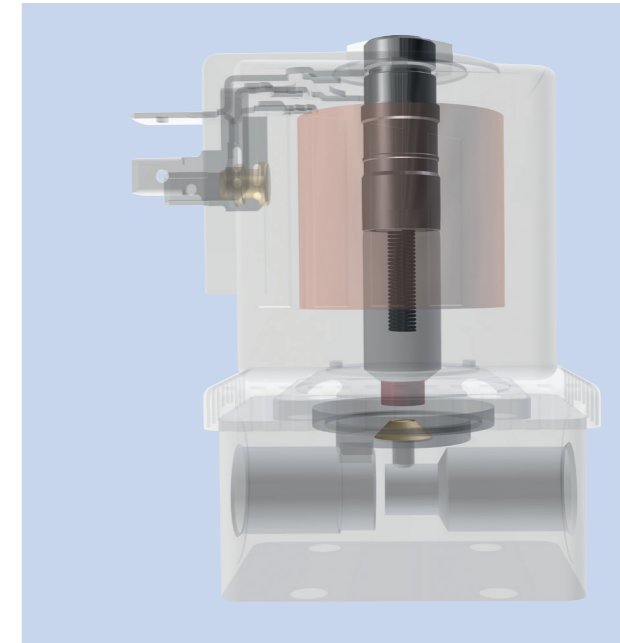

Single pulse coil

Construction:

The construction of the single pulse coil is identical to that of the single magnetic coil. Pulse coils receive only a short pulse for piloting, to move the armature into its end position. A permanent magnet keeps the armature in its end position after the coil is switched off. To switch the valve back again, a renewed pulse is needed, which runs through the coil in reverse direction, to release the armature from the permanent magnet. The pilot control must change polarity in this design.

Application:

Applications with low electrical power.

Special features:

Low inherent heat, switching of the polarity can also be achieved with the 2508 LR connector, the coil has 2 connections (+/-).

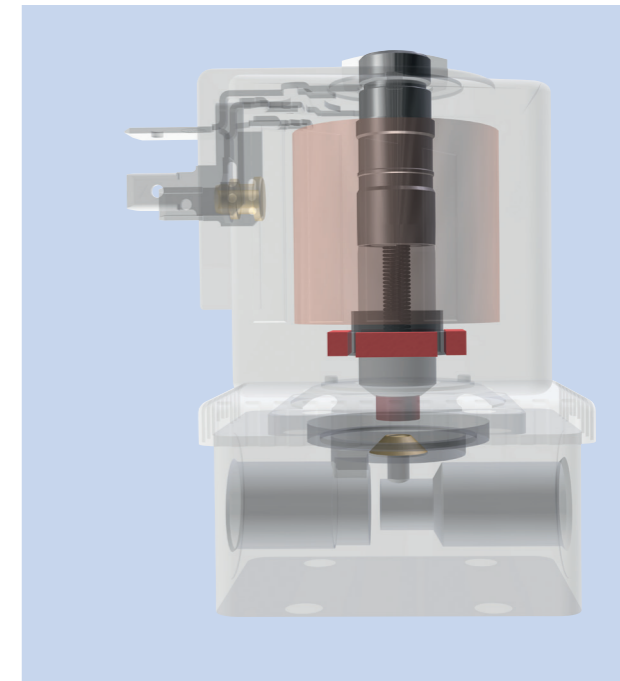



Double coil (e. g. Type 131)

Construction:

This coil makes use of two independent windings with high and low power, based on the principle of the single magnetic coil. Electronics integrated in the moulding mass switch after a short starting moment from the winding with high power to the winding with low power.

Application:

Direct-acting and fixed coupled valves with a large diameter or high starting power.

Special features:

Low power consumption, built-in converter for AC and DC operation as standard equipment, low inherent heat, maximum of 6 to 10 switching cycles per minute.

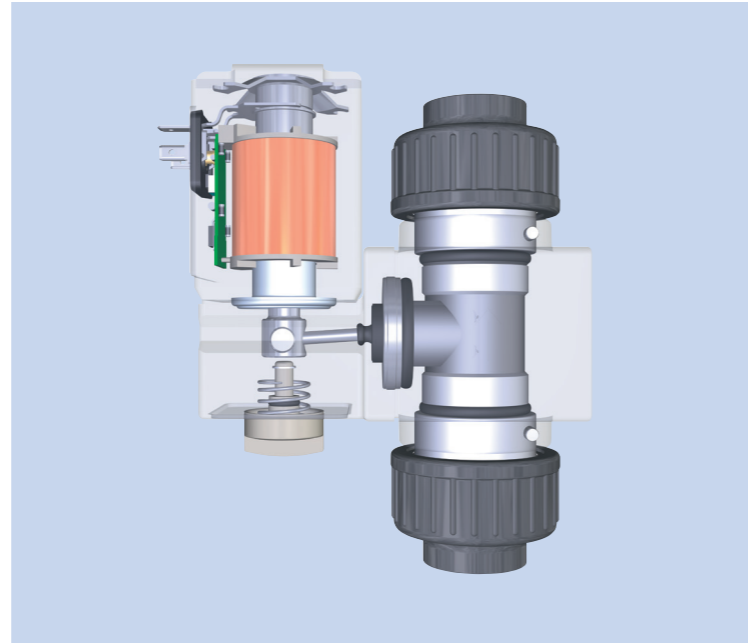

TwinPower

Construction:

To generate a higher magnetic force than with single coils, the TwinPower coil features two parallel windings on the coil yoke. After a short starting phase integrated electronics (see also double coil) switch the coils from parallel to series connection, reducing the power consumption to 1/4 the starting power.

Application:

Miniature valves with a large diameter in compact installations.

Special features:

High switching frequency, low inherent coil heat, LED switch signalling.

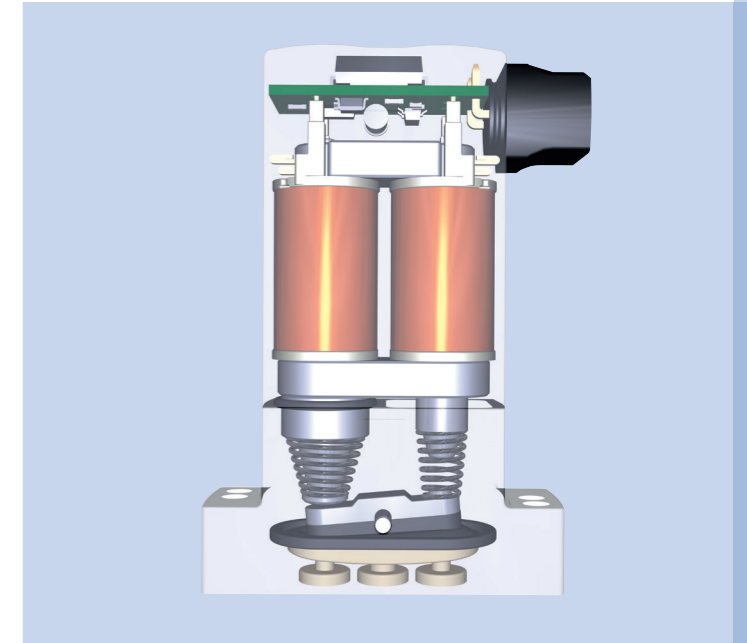

Pulse double coil (e. g. Type 330)

Construction:

The two pulse coils are wound independently, one above the other, based on the principle of the single magnetic coil. In the event of a current pulse, the first coil performs the movement of the armature and magnetisation of the yoke. The residual magnetism (remanence) in the magnetic circuit holds the armature in position when the coil is switched off. A pulse to the second winding counters the remanence and the armature is moved to its original position.

Application:

Direct-acting pivoted armature valves.

Special features:

Low power consumption, no polarity switching by the controller, the coil has three connections (P1/N/P2).

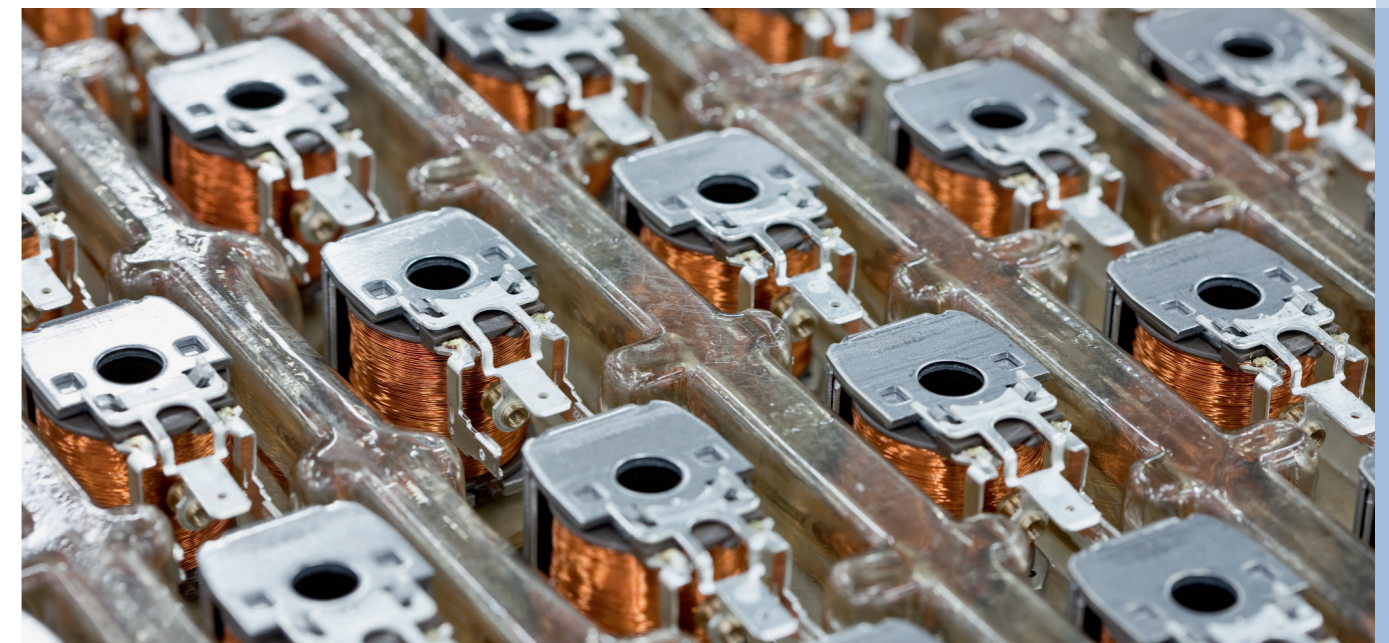
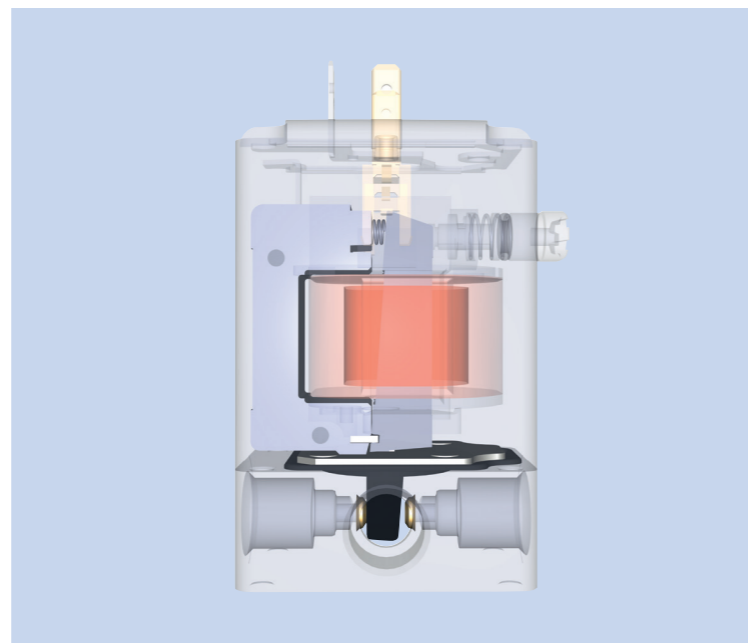

Direct-acting Valve Anatomy

Coil

The coil forms the drive system of the solenoid valve. Electrical energy is converted to a controlled magnetic force.

Plunger

The plunger is a precision turned part made of magnetic steel. It is moved by the magnetic field generated in the coil.

Closing spring

The closing spring presses the plunger onto the valve seat to close it.

Electrical connection

A broad spectrum of electrical connections is available. Many magnetic systems are designed for protection type IP 65.

Plunger guide tube

Precision machined tube made of non-magnetic steel, in which the plunger is guided.

Shading ring (AC only)

This is needed only for AC coils. The shading ring represents a coil with one winding, which during zero crossing of the AC voltage induces sufficient residual magnetism to keep the plunger from dropping.

Air gap and stopper

The stopper is part of the magnetic circuit and is firmly fastened to the plunger guide tube. The air gap is the distance between the stopper and the plunger. There should be no gap when the plunger is attracted, in order to generate an optimal magnetic force.

Encapsulation

The coil is cast in polyamide or epoxy to protect it against damage and moisture. The coil temperature and ambient influences determine the material used for encapsulation.

Diameter

The diameter refers to the inner diameter of the valve seat. It is relevant for the flow rate calculation.

Process connection

The process connection is used for the fluidic connection of the valve in the pipe system. Standard DIN and ANSI connections are available, as well as special versions.

Valve seat

The valve seat is the essential fluidic element. It is manufactured with high precision and formed according to the sealing principle.

Seal

The seat seal is the heart of the fluidic system. It is always adapted to the valve pressure, media temperature and chemical resistance.

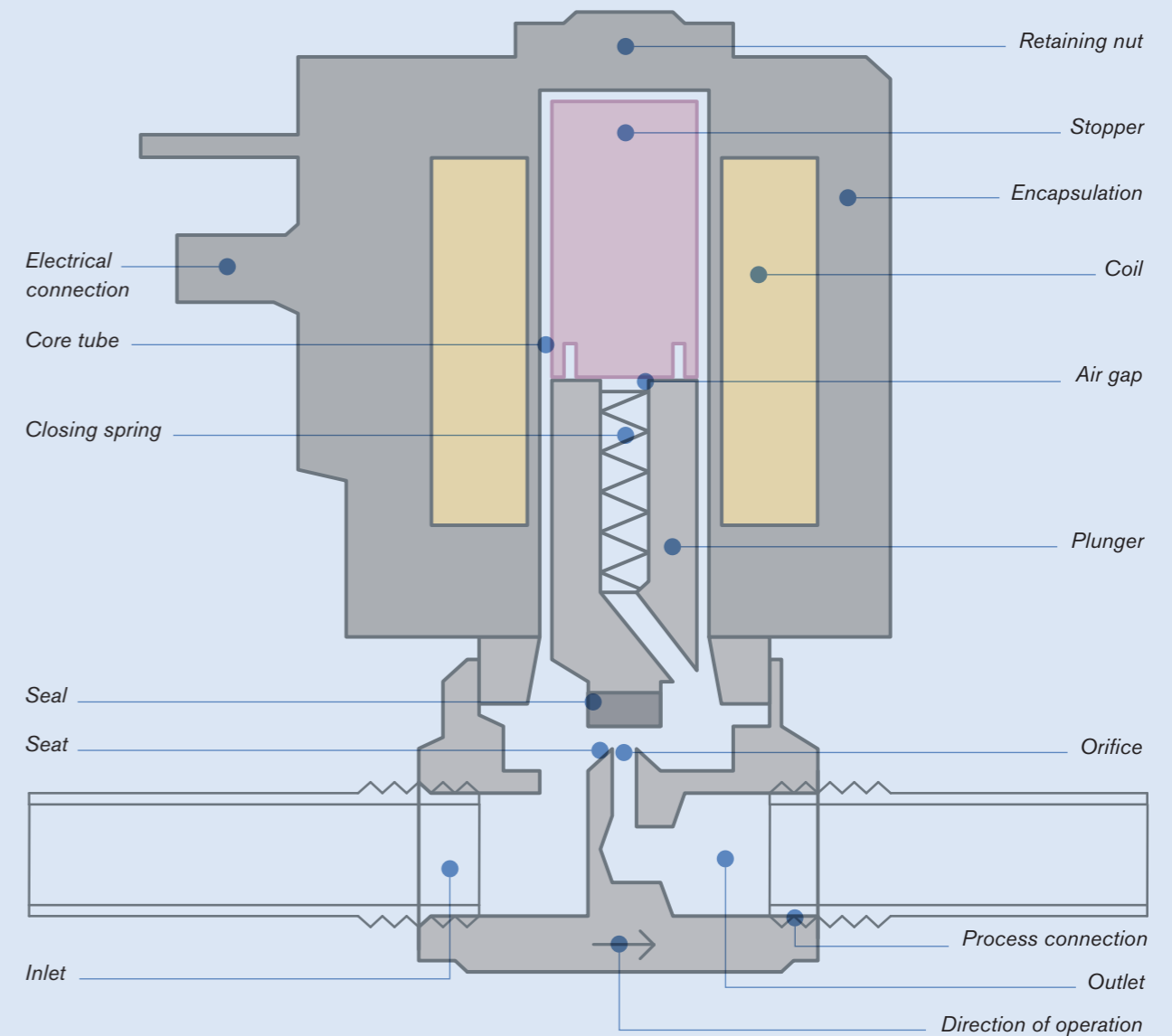

Solenoid valves are the most frequently used control elements in fluidics. Their tasks are to shut off, release, dose, distribute or mix fluids (liquids and gases). They are confronted with many different requirements in a plethora of application environments and must offer:

- fast and safe switching
- high reliability
- long service life
- good medium compatibility of the materials used
- low control power
- compact design

Direct-acting 2-way plunger valve

Function:







The main components of this valve type are a coil, a closing spring, a valve body cover and the valve body with the seat. Without current the path to the outlet is blocked (normally closed), since the closing spring, supported by the pressure of the medium, presses the plunger onto the valve seat. If current flows through the coil, the latter generates a starting force, which pulls the plunger and the seal against the spring force and draws the medium upward. The channel is opened for the medium.

Application:

This cost-effective valve type is used in universal applications for neutral and clean liquids, gases and vapours. Versions with special high-quality materials also allow their use in mildly acidic and alkaline solutions. The direct-acting 2-way plunger valves therefore can be used for diverse applications, such as shut-off, dosing, filling and ventilation.

Special features:

Due to a spring-damped seat seal, these valve types have a long service life. Especially noteworthy are the increased switching cycles and service life due to sliding ring bearings. These products are also suitable for high pressure and temperature ranges.

Type	7011	6013	6027
			
Process connections			
Diameter [DN in mm]	1.2 ... 2.4	2.0 ... 6.0	1.2 ... 12.0
Pressure range [bar]	0 ... 30	0 ... 25	0 ... 250
Temperature [°C]	-10 ... +140	-40 ... +180	-40 ... +180

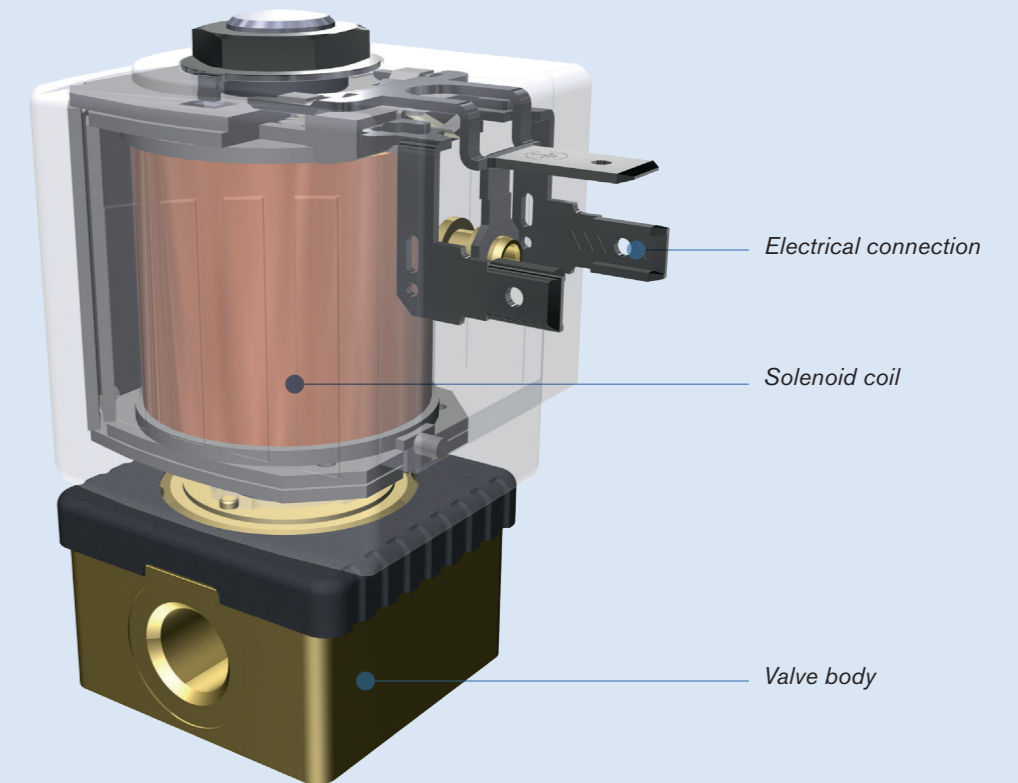

2/2-way plunger valve type 6013

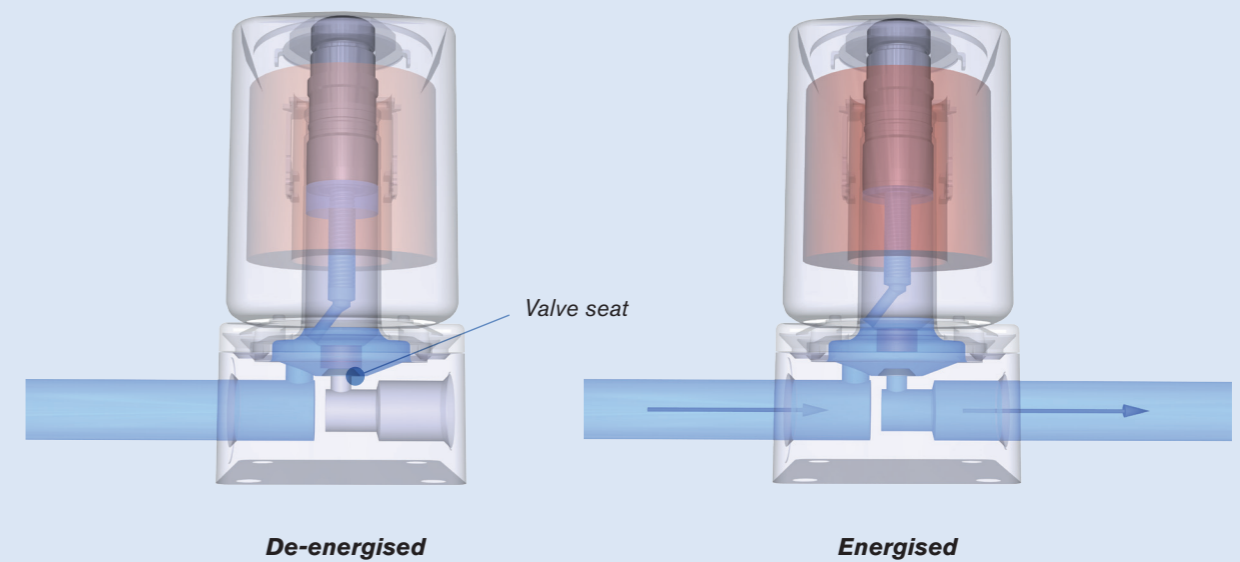

Direct-acting 3-way plunger valve

Function:



The functioning principle of the direct-acting 3-way plunger valve depends on how the fittings are connected to the fluid system. As opposed to the 2-way plunger valve it has two valve seats and one return flow. If no electric voltage is present, a normally closed 3/2-way valve allows no passage from the pressure connection P to connection A (outlet), since a conical spring presses the plunger onto valve seat 1. At the same time A is directly connected to R (return flow) and valve seat 2 is opened. If the coil is energised the plunger is pulled in and seals valve seat 2. The path between A and R is therefore blocked. At the same time valve seat 1 is opened and the channel between P and A is opened for the medium.

Application:

These valves can be used in diverse applications, such as mixing, distribution, ventilation, dosing, etc. of neutral gaseous and liquid media. This type is frequently used as a pilot valve for larger pneumatically actuated valves.

Special features:

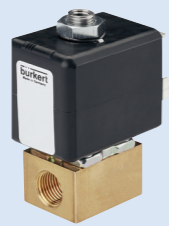
Special features of this valve type are the convenient, service-friendly manual override, the energy-saving pulse design and its suitability for use in explosive areas. In addition there are versions that are suitable for high-temperature media (hot water, hot air and steam).

Type	7012	6014	0355
			
Process connections			
Diameter [DN in mm]	1.2 ... 1.6	1.5 ... 2.5	2.0 ... 4.0
Pressure range [bar]	0 ... 18	0 ... 16	0 ... 16
Temperature [°C]	-10 ... +140	-10 ... +100 (Polyamid coil) -10 ... +120 (Epoxy coil)	-10 ... +180

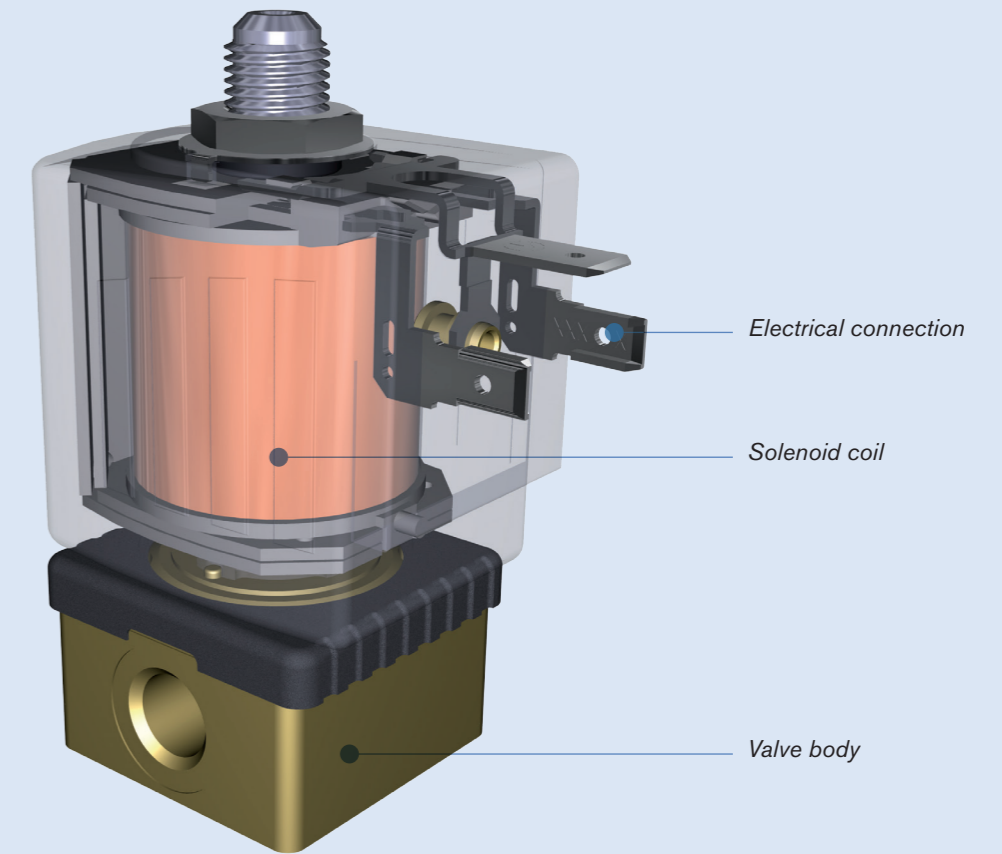

3/2-way plunger valve type 6014

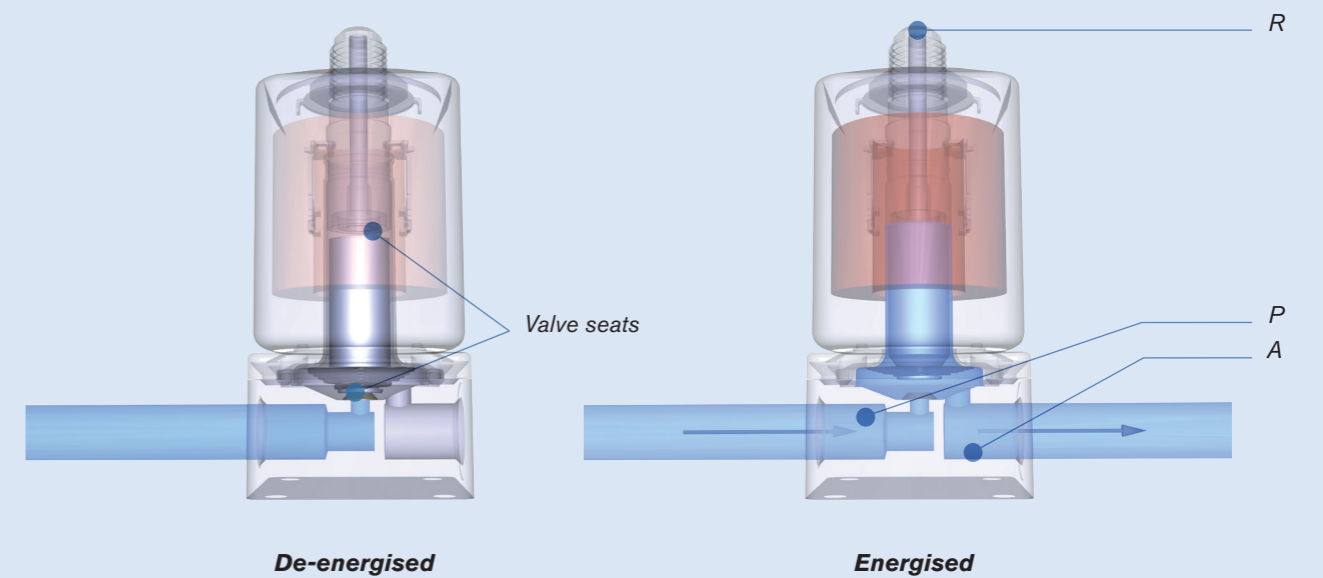

Direct-acting toggle valve

Function:

The valve operates according to the lever principle and can therefore also directly switch large diameters. It is available both as a 2/2-way and a 3/2-way valve.

The armature acts horizontally on a fixed coupled toggle arm. The sealing cylinder located on the lower lever is pressed by the horizontal motion onto the valve seats. The plastic encased metal lever comprises one unit with the gas-tight lead-through. Due to this design the actuator is media separated from the fluid body.

Application:

Media separation makes this valve especially suitable for use in critical acidic and alkaline solutions or in media that contain particles. Due to the large diameters it is often used as an emptying and mixing valve.

Special features:

The energy-saving version with power reduction uses the double coil technology with integrated cast electronics. They are certified worldwide as AC, DC and UC versions and fulfil the voltage requirements for European rail transport.

These valves are equipped with a locking service-friendly manual override and offer the capability of potential-free electrical feedback of the switching position.

Type	0131	0131	0131
			
Process connections	 		
Diameter [DN in mm]	10 ... 20	10 ... 20	10 ... 20
Pressure range [bar]	0 ... 3	0 ... 3	0 ... 1
Temperature [°C]	-10 ... +130	-10 ... +130	-10 ... 80

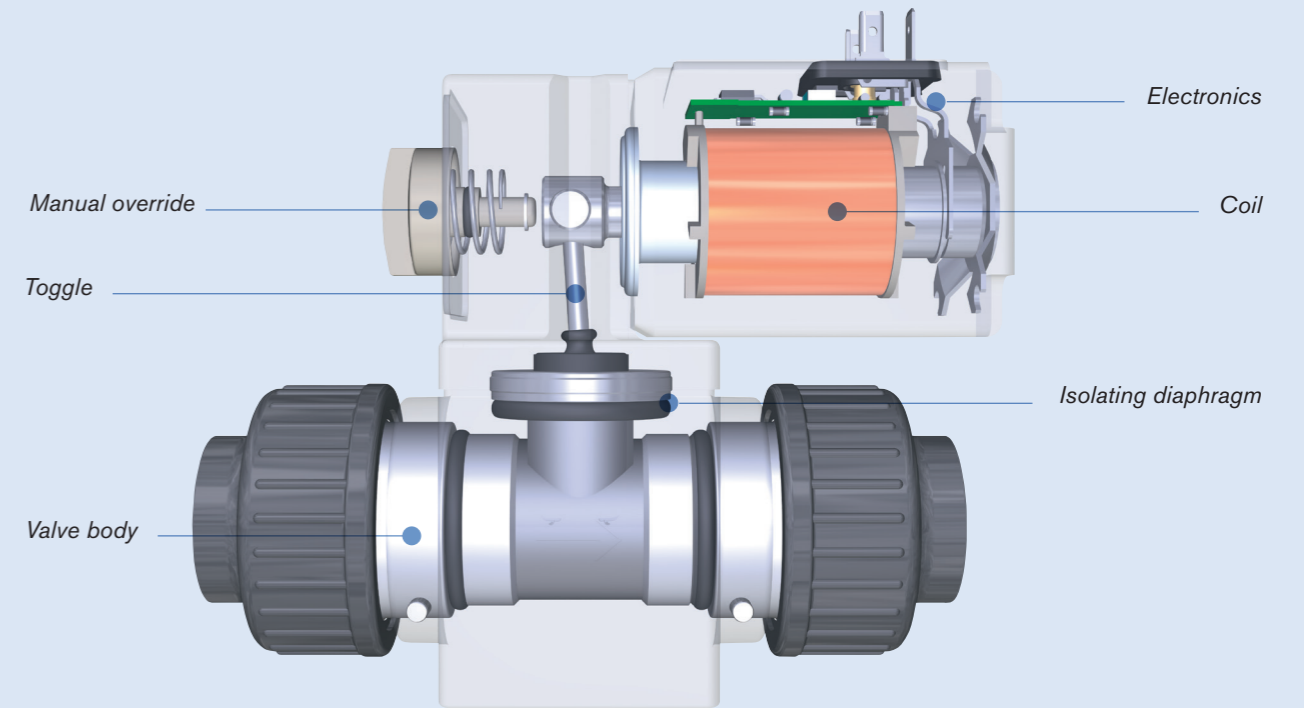

2/2-way toggle valve type 131

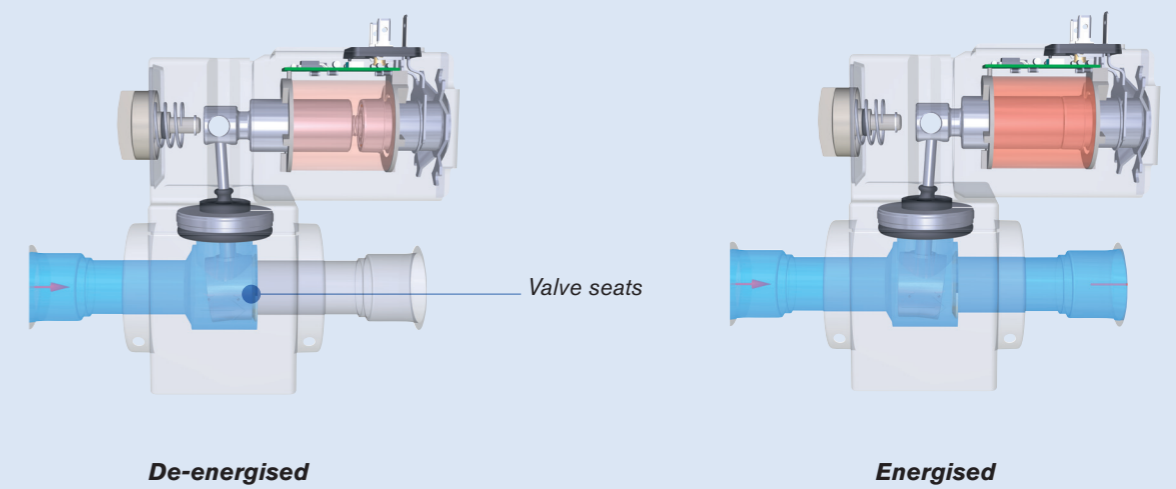

Direct-acting pivoted armature valve

Function:



This type of valve uses a pivoted armature, a flexible separating diaphragm, two valve seats and one coil. They can be used both as 3/2-way and 2/2-way versions. Under voltage the pivoted armature is pulled against the force of the spring and the path between P and A (outlet) is opened. At the same time the channel between P and B is closed. Without current the pivoted armature closes valve seat 1 and the medium can flow between connection P and B.

Application:

The use of a separating diaphragm, which separates the media chamber from the magnetic system, makes it possible to use these valves for the control of corrosive, contaminated and aggressive fluids as well as for vacuum. These valves are equipped with a lockable manual override and offer the unique capability of electrical feedback of the switching position, which results in increased safety.

Special features:

Versions for use in explosive areas are available, as well as different materials for media-contacting components. Decades of engineering experience make it a highly reliable, low-maintenance valve.

Type	0330	0331	0121
			
Process connections			
Diameter [DN in mm]	3.0 ... 5.0	2.0 ... 4.0	2.0 ... 8.0
Pressure range [bar]	0 ... 10	0 ... 16	0 ... 4
Temperature [°C]	-30 ... +80	-30 ... +90	-30 ... +90

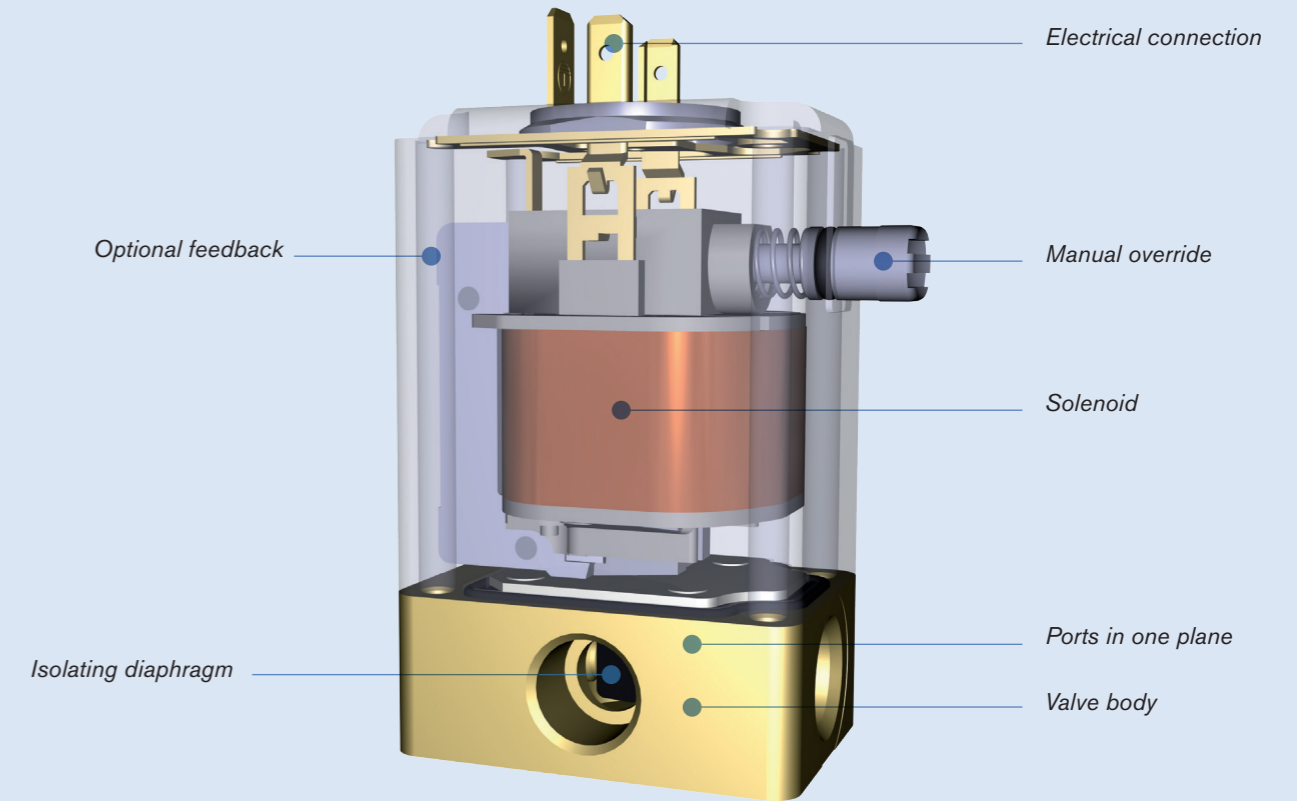

Pivoted armature valve type 330

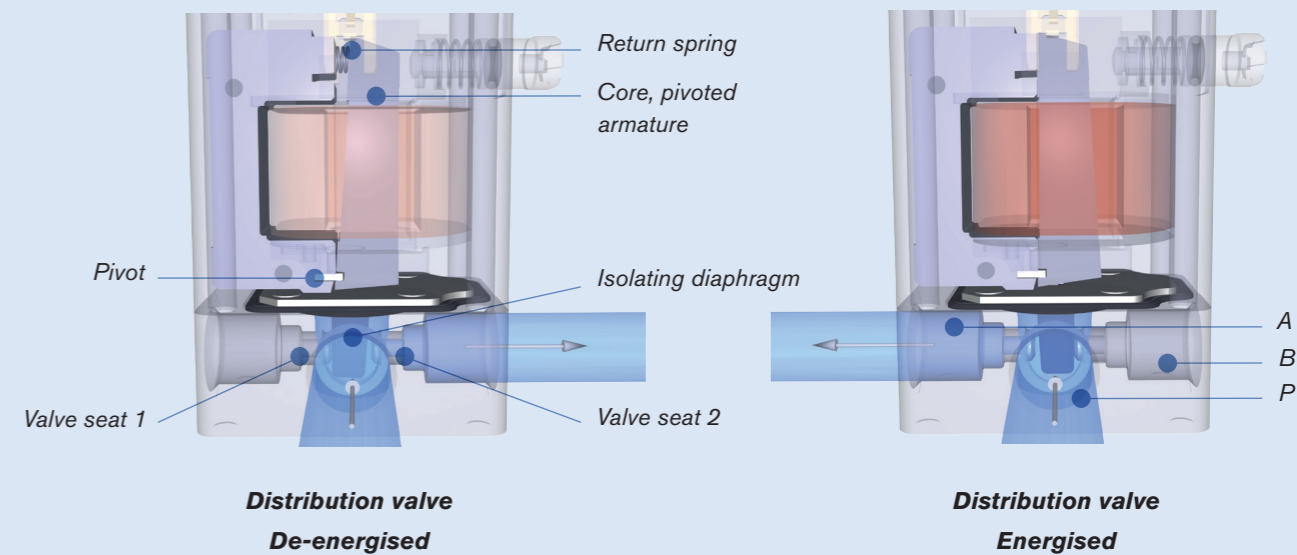

**Distribution valve
De-energised**

**Distribution valve
Energised**

Direct-acting pivoted rocker valve

Function:





The special feature of direct-acting rocker valves is that all orifices are located on one plane in the valve body. This functioning principle is suitable both for 2/2-way and for 3/2-way valves. The valve consists essentially of four main elements: magnetic coil, spring, rocker and two valve seats. In a 2/2-way valve a spring presses one side of the rocker against one of the two valve seats, which is sealed in this way. As soon as the coil is energised, supported by an additional spring it pulls the part of the rocker that was previously pressed against the valve seat. This creates a "rocking motion" and the valve seat opens. At the same time the other side of the rocker is pressed against the blind seat. Since it is not completely closed, medium can now flow unhindered through the valve.

Application:

In the standard version such valves are used for the control of neutral gases and fluids. They can be used either as single systems or as pilots for pneumatic valves in normal or explosive environments. Rocker valves can also be equipped with a separating diaphragm to separate the valve mechanism from the medium. This makes them suitable also for switching aggressive and high purity media.

Special features:

The design with an integrated membrane is the basis of the MicroFluidics series, in which minimal internal volumes and excellent flushability are especially important.

Type	6106	0127
		
Width	16 mm	16 mm
Process connections		
Diameter [DN in mm]	0.9 and 1.2	0.8 ... 1.6
Pressure range [bar]	0 ... 10	0 ... 6
Temperature [°C]	-10 ... +55	-10 ... +55

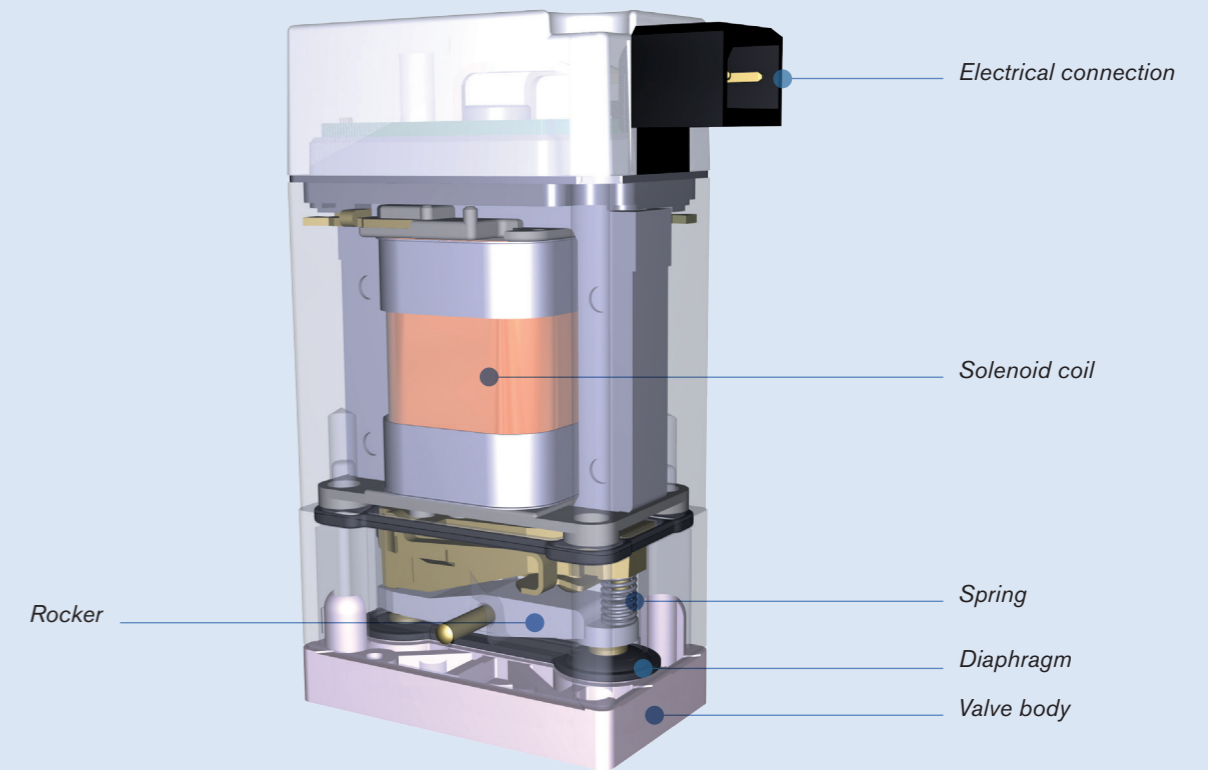

Direct acting 3/2-way rocker valve type 127

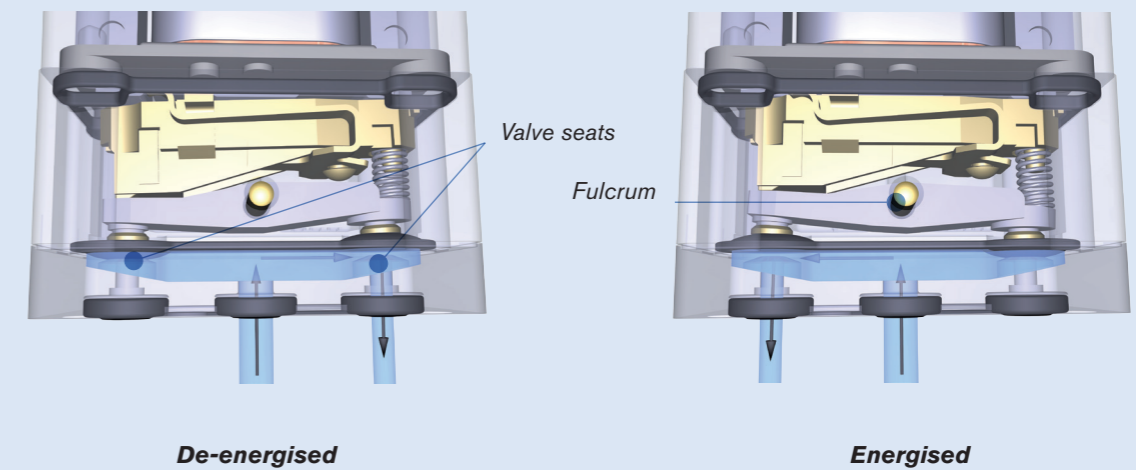

Direct-acting TwinPower rocker valve

Function:

TwinPower valves are based on the time-tested rocker technology. The special feature of these valves is the coil: It is not a conventional coil with a single winding, but rather two coils that are arranged parallel to each other so that they have more force for switching. The rocker is moved by a plunger and is stabilised by two springs. The valves are available in 2/2-way and 3/2-way versions. The plunger is pulled by the innovative TwinPower coil technology, which triggers the movement of the rocker. In the 2/2-way version this causes the channel to open and the medium can flow through the valve. The 3/2-way version enables switching between two channels.

Application:

The valves are used for the control of gases and fluids in analytical applications. They are ideal for switching aggressive and high purity media, since the separating diaphragm ensures a hermetically sealed coil and only high-quality plastics are used as the sealing and body material.

Special features:

The valves, relative to their size, offer excellent flow rates and outstanding sealing properties when used with gaseous media.

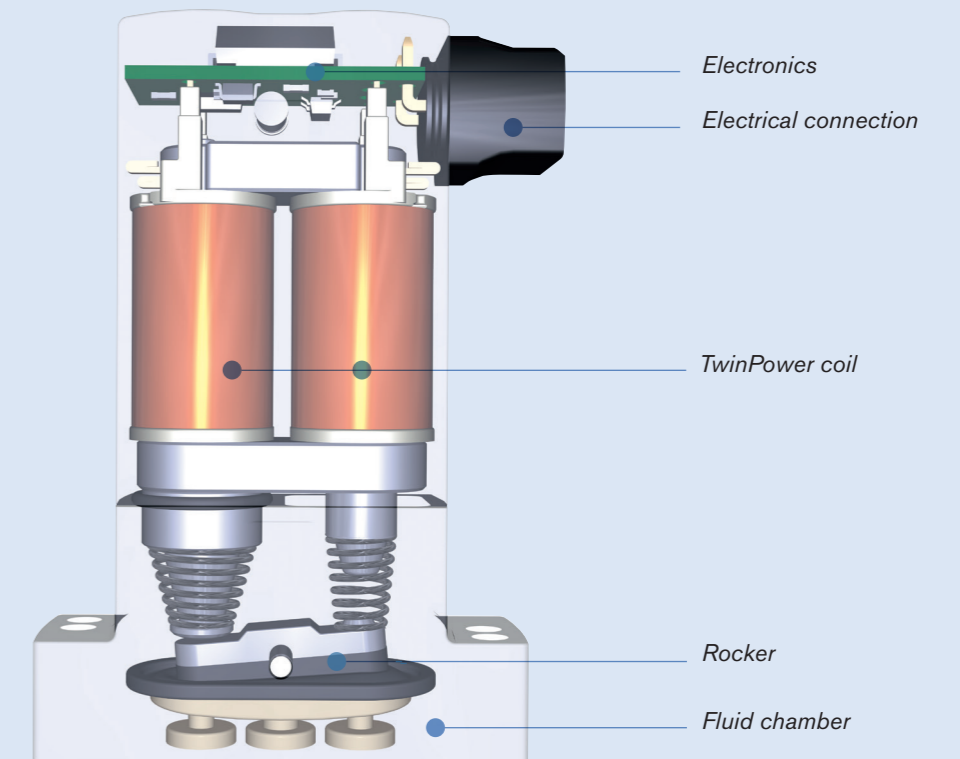

Direct-acting 3/2-way rocker valve type 6624

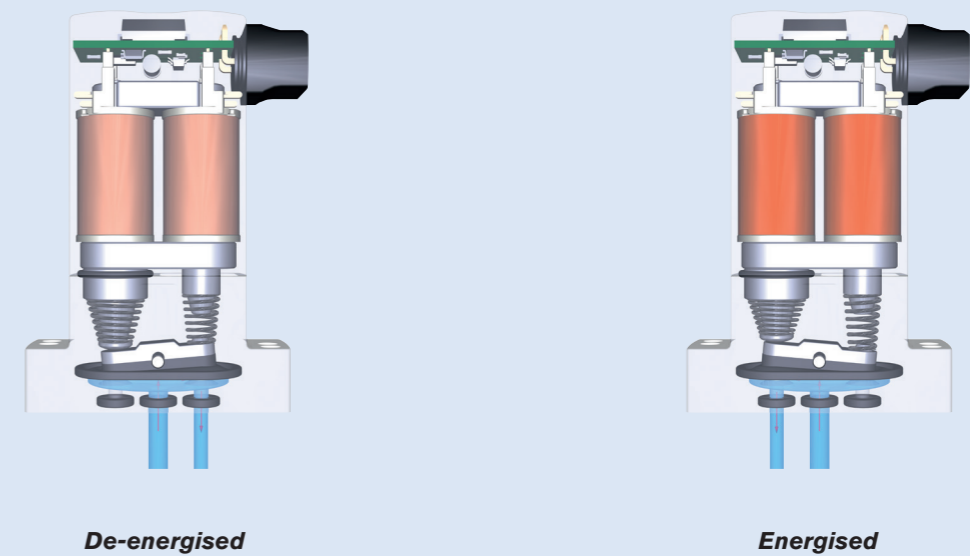

Type	6624	6626	6628
Width	10 mm	16 mm	22 mm
Process connections			
Diameter [DN in mm]	0.8 ... 1.6	2.0 ... 3.0	2.0 ... 3.0
Pressure range [bar]	Vak ... 5	Vak ... 3	Vak ... 5
Temperature [°C]	-5 ... +50	-10 ... +50	-10 ... +55

Direct-acting flipper valve

Function:





The functioning principle of this valve type is characterised by a movable flipper element: A flipper valve uses a technologically advanced, fully encapsulated flexible seal system between two opposing seats. The flipper moves around a bearing point beneath the valve seats. The movement of the permanent magnet causes the switch element to seal one of the two opposing valve seats and connects the other seat with the working connection.

Application:

These valves are ideal for applications requiring maximum fluidic capacities in extremely compact installations. They are frequently used for repeatable control of neutral gases and liquids. Flipper valves are also used as pilot valves for pneumatic applications both in normal and explosive environments.

Special features:

Media separation by means of a diaphragm and the low heat accumulation of the high-performance coil make it possible to use this type for aggressive and high-purity media. Flipper valves feature short switching times, low switching noises and minimal wear.

Type	6144	6144 Ex	6650
			
Width	10 mm	10 mm	4.5 mm
Process connections			
Diameter [DN in mm]	0.6	0.6	0.4 ... 0.8
Pressure range [bar]	0 ... 10	0 ... 7	Vak ... 7
Temperature [°C]	0 ... +55	0 ... +55	+15 ... +50

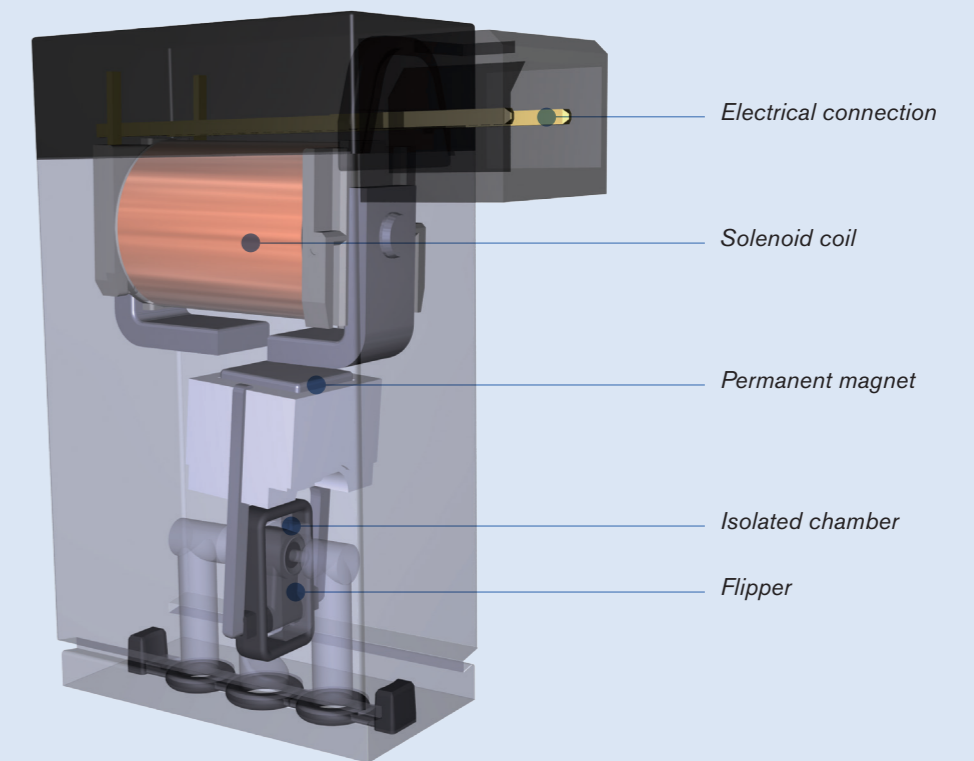

Direct acting 3/2-way flipper valve type 6144

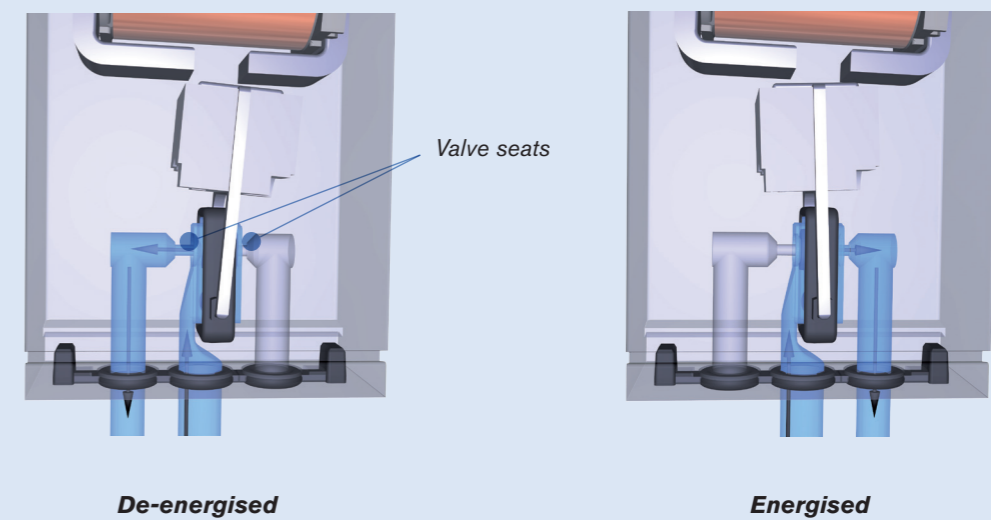

De-energised

Energised

Servo-assisted Valve Anatomy

Pilot Valve

All of the functional principles explained for direct-acting valves (plunger, pivoted armature, rocker and flipper valves) can be used for pilot valves.

Chamber (above diaphragm)

Pressure is equalized in the chamber and is the space into which the diaphragm or piston recedes to allow flow.

Pilot channels

Allow fluid to move out of the chamber and from the pilot to downstream to enable the fluid to assist in opening the main seal.

Equalization hole/channel

Ensures that the inlet pressure and the pressure in the chamber above the diaphragm or piston are slowly equalised in order to close the valve.

Above the seat flow

In all pilot-controlled valves the flow takes place above the valve seat.

Spring

The spring in the chamber supports the media pressure during closing of the valve. In valves that are exposed to aggressive chemical fluids the spring is avoided. The media pressure alone then closes the valve.

Main Orifice

The area on which the media pressure will act and the gap through which the media will flow when the valve is energized. Along with the contours of the valve it governs the pressure drop and the flow rate of the valve.

Process connections

Many fluidic sizes and connections are available to meet local geographic or industry specific standards.

Seal

A soft material, either a diaphragm or a flat seal attached to the underside of a solid piston or a plunger which halts the flow of fluid from one side of the main orifice to the other.

Seat

A raised area at the diameter that concentrates the pressure of the seal. Press-fit seats made of VA are used in case of potential abrasion or cavitation.

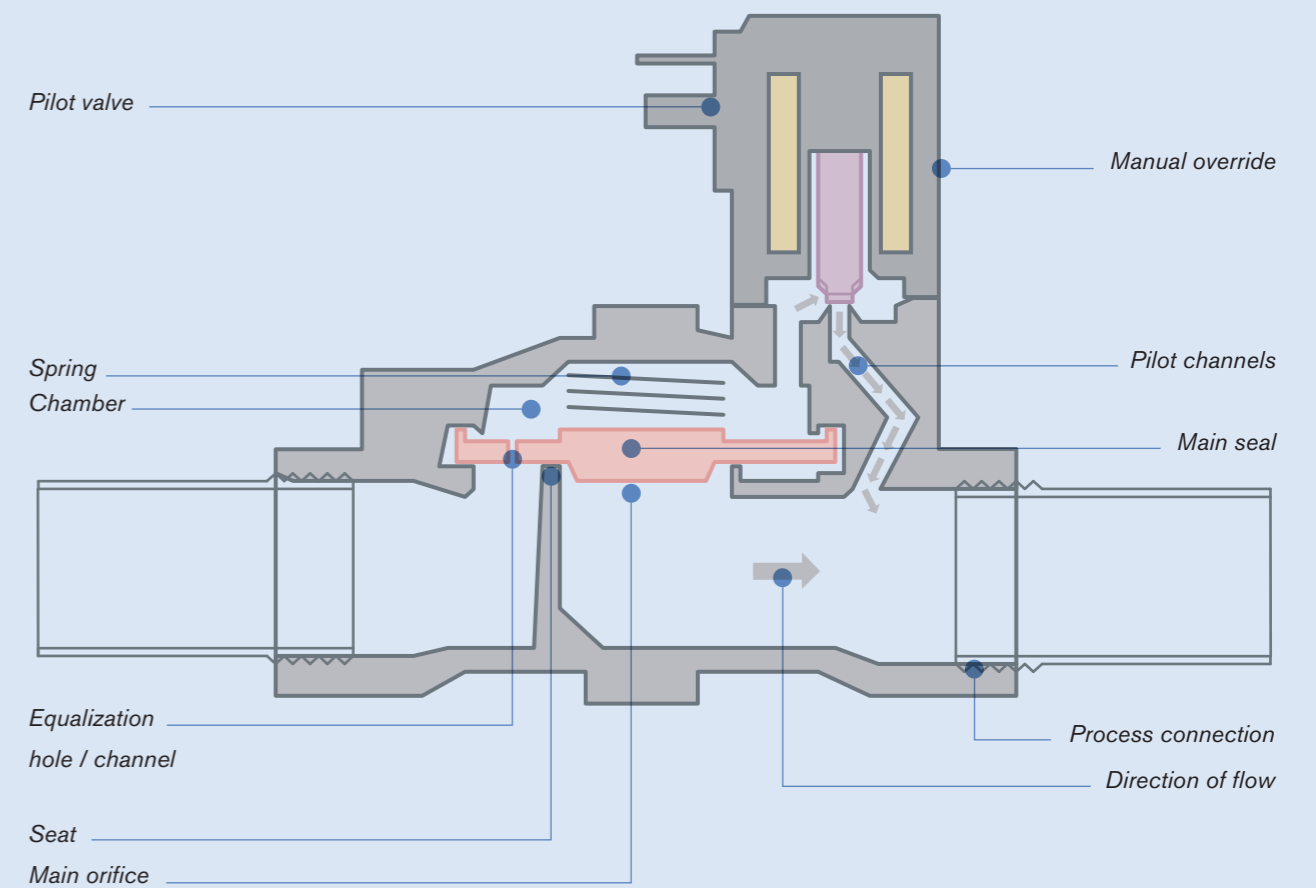

Opening large orifices using the direct acting method would require enormous and expensive coils. Therefore servo assisted valves use the power of the fluid to open the flow channel by controlling a small pilot channel to alter the forces on a larger main seal.

Servo-assisted:

Diaphragm valve with plunger pilot control

Function:





This functioning principle uses a direct-acting plunger valve as the pilot valve and a flexible diaphragm as the seal for the main seat. As soon as the pilot valve opens, the fluid chamber above the diaphragm is emptied. The media pressure within the diaphragm raises the diaphragm and opens the valve so that the medium can flow. If the pilot valve is closed, the media pressure above the diaphragm builds up again through the small compensation opening and the closing process is supported additionally by the compression spring. A minimal differential pressure between the inlet and outlet is necessary for complete opening and closing.

Application:

The main areas of application for this pilot-controlled solenoid diaphragm valve are clean liquid or gaseous media such as compressed air, water, hydraulic oils, etc. The small pilot valve makes them less expensive than direct-acting valves for use with higher pressures and larger diameters.

Special features:

Since pilot-controlled valves (also: servo-assisted valves) have only a small pressure equalisation hole in the diaphragm, they are susceptible to dirt particles and crystallising media, which can clog the hole. Bürkert valves are designed as soft stop valves. Ex or low power versions are virtually unproblematic compared with direct-acting valves, since the pilot control valve only has lower power consumption.

Type	6281 EV	6281 EV
		
Process connections		
Diameter [DN in mm]	10 ... 50	10 ... 40
Pressure range [bar]	0.2 ... 16	0.2 ... 16
Temperature [°C]	-30 ... +120	-30 ... +120

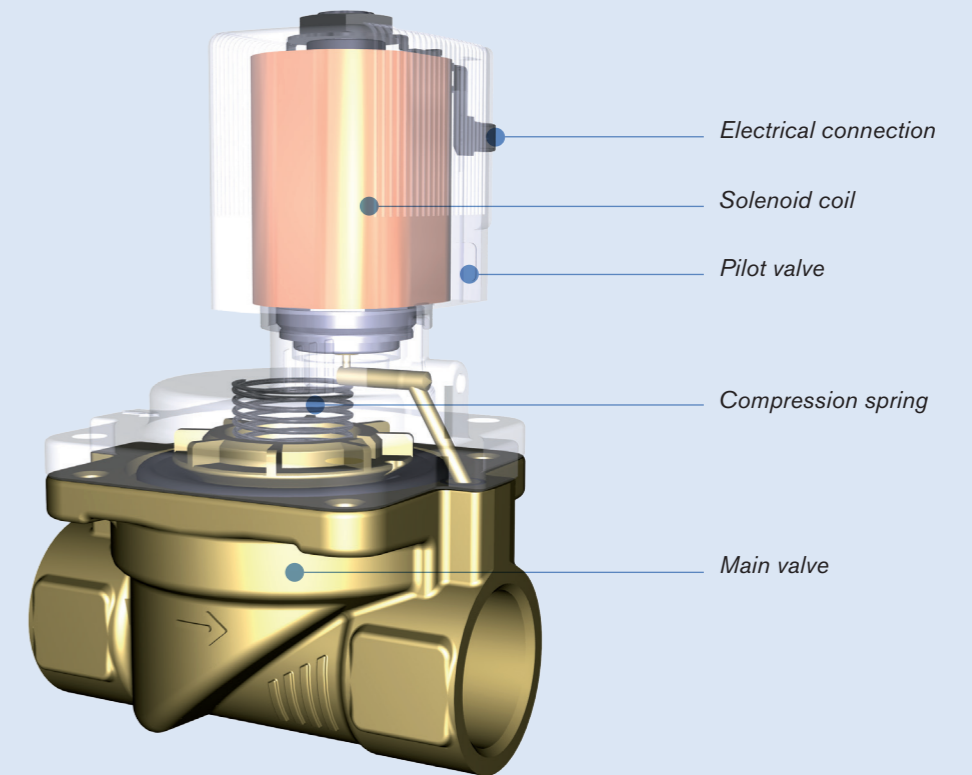

Servo-assisted diaphragm valve type 6281 EV

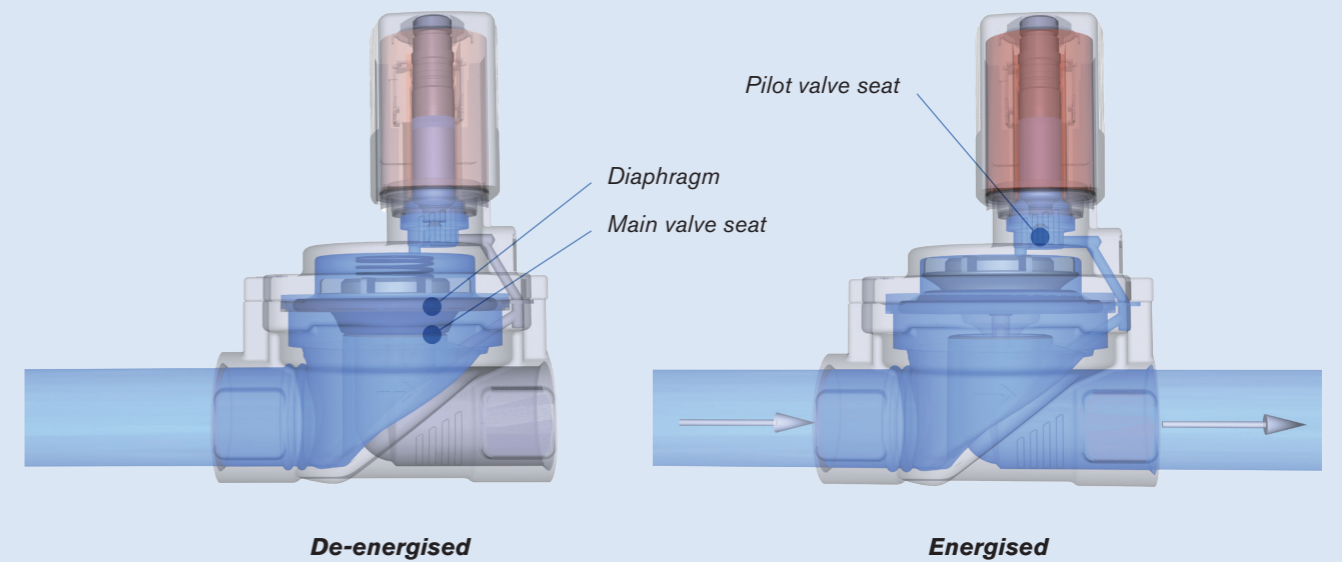

Servo-assisted:

Coupled diaphragm solenoid valve with plunger pilot control

Function:







This functioning principle uses a direct-acting plunger valve as the pilot valve and a flexible diaphragm as the main seal. As soon as the pilot valve opens, the fluid chamber above the diaphragm is emptied. The media pressure within the diaphragm raises the diaphragm and opens the valve so that the medium can flow. If the pilot valve is closed, the media pressure above the diaphragm builds up again through the small compensation opening and the closing process is supported additionally by the compression spring. This valve type can switch without differential pressure, since the diaphragm holder of the main valve is connected to the armature rigidly or by means of a spring. The pilot valve alone is capable of partially opening the main valve.

Application:

The main areas of application for pilot-controlled diaphragm solenoid valves are liquid or gaseous media such as compressed air, water and hydraulic oils in closed circuits in which little or no differential pressure is present for opening and closing.

Special features:

Type 290 features a soft-kick function for a longer service life. All of the DC versions feature energy-saving power reduction. Type 6213 EV uses a spring as a coupling for "diaphragm-friendly" opening of the main seat in frequent working cycles.

Type	0290 EV	6213 EV	6213 EV HP00
			
Process connections			
Diameter [DN in mm]	12 ... 50	10 ... 40	13 ... 20
Pressure range [bar]	0 ... 16	0 ... 10	0 ... 10
Temperature [°C]	-30 ... +120	-30 ... +90 (Polyamid coil) -30 ... +120 (Epoxy coil)	0 ... +120 (Epoxy coil)

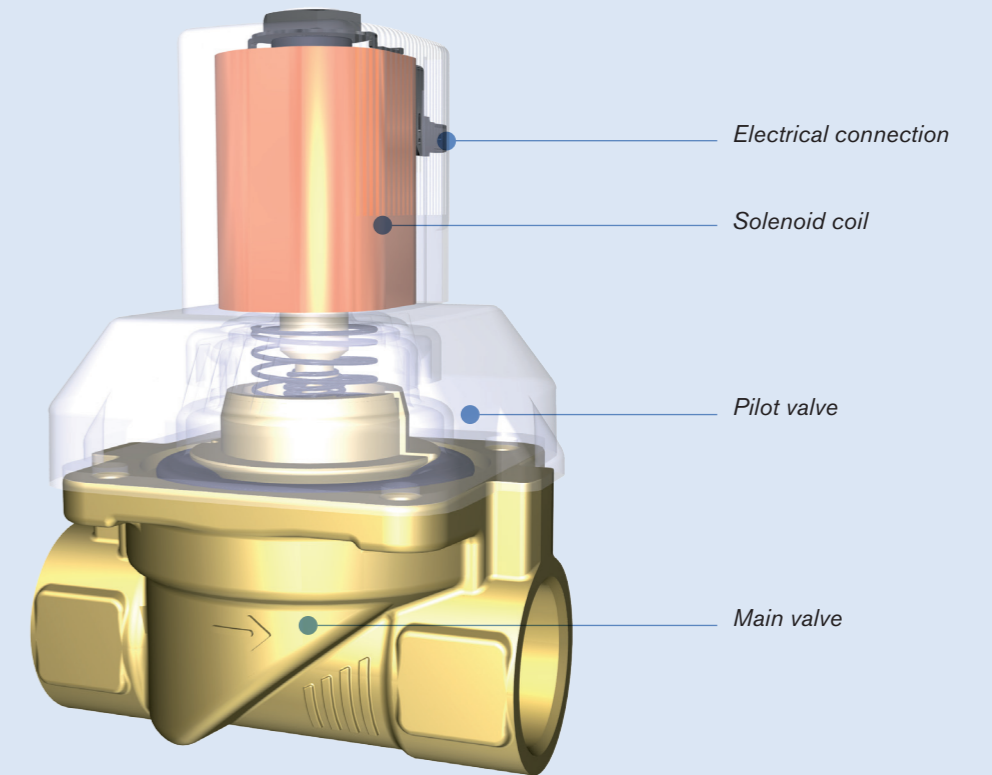

2/2-way spring coupled servo-assisted solenoid valve type 6213 EV

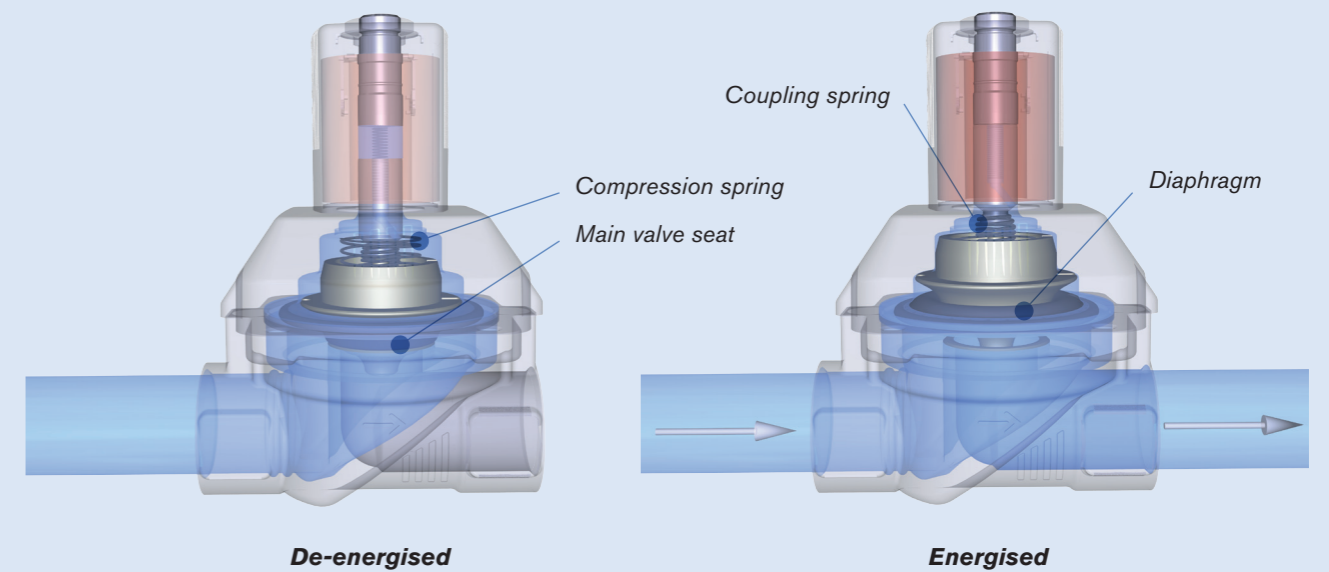

Servo-assisted: Piston valve with plunger pilot control



Function:

This operating method uses a direct acting plunger valve as the pilot valve and the main valve seal located on the base of a solid piston which moves vertically through a cylindrical chamber. The fluid chamber above the piston is relieved when the pilot opens. The medium pressure beneath the piston lifts the piston and opens the valve allowing flow. When the pilot valve is closed, the medium pressure is allowed to build up again above the piston through the equalizing orifice in the piston body and closing is aided by the force of the compression spring.

These valves require a minimum pressure differential to exist between the inlet port and the outlet port and are limited to controlling the same clean media as the non-isolated plunger pilot.

Application:

The main area of application for this servo-assisted solenoid piston valve is the reliable control of compressed air, neutral gases and steam up to 160 °C with a high number of strokes in diameters from DN 12 to 50 mm. Piston valves are especially robust for switching of compressible media such as gas and steam.

Type	5404
	
Process connections	 
Diameter [DN in mm]	12 ... 50
Pressure range [bar]	1 ... 50; 1 ... 80 (high pressure version)
Temperature [°C]	-10 ... +160

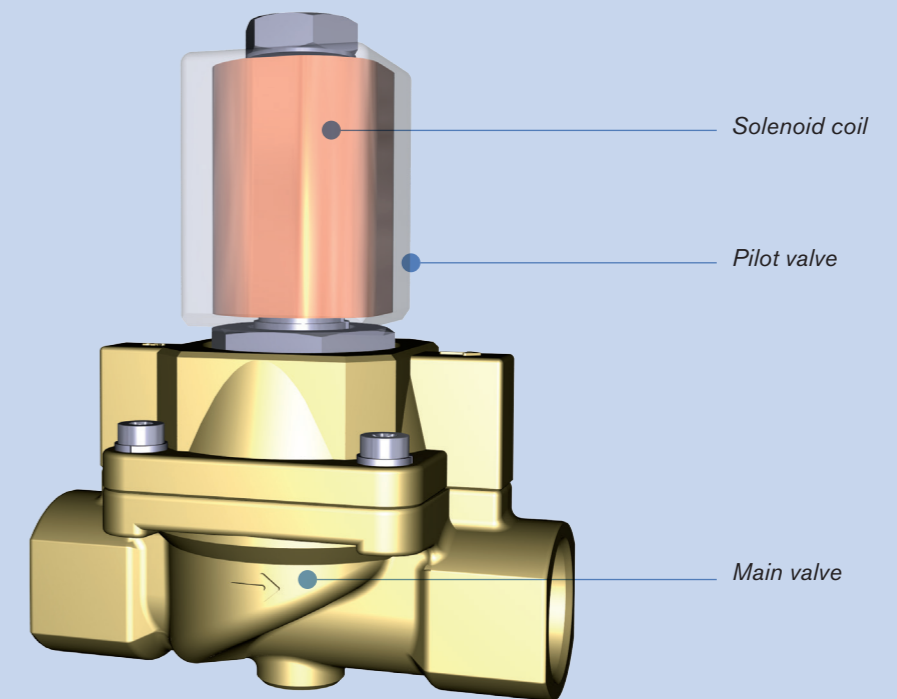

2/2-way servo-assisted piston valve type 5404

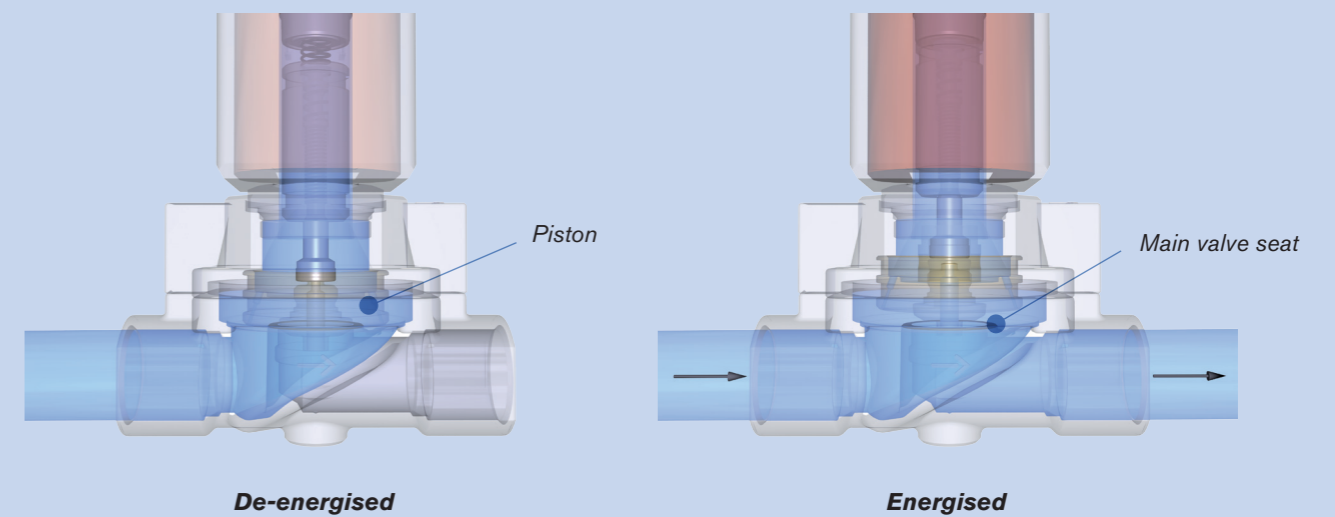

Servo-assisted:

Fixed coupled piston valve with plunger pilot control

Function:





This functioning principle uses a direct-acting plunger valve as the pilot valve and a fixed coupled piston as the main seal. In closed state the piston seals the main valve seat. If the valve is energised, the pilot valve opens the pilot seat. The media pressure and the armature of the pilot valve cause the piston to move upward and release the main valve seat. If the pilot valve is switched off, this design provides for slow, impact-free closing of the valve. As opposed to the other pilot-controlled valve models, these valve types switch also without differential pressure, since the pilot valve alone opens the main valve seat.

Application:

Fixed coupled valves are used in applications with little or no differential pressure, since the force of the pilot control valve alone is also sufficient to open the main seat. Neutral gases and steam are among the primary applications.

Special features:

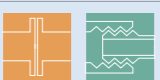
Special features of the 6407 series are a longer service life due to sliding ring bearings and integrated power reduction. Type 6240 features a very compact design, stainless steel body and a plastic piston. In addition, the latter valve is also available in an explosion-protected version.

Type	6407	6240
		
Process connections		
Diameter [DN in mm]	13 ... 50	6, 12, 13
Pressure range [bar]	0 ... 10	0 ... 40, 0 ... 250 (high pressure version)
Temperature [°C]	-40 ... +150	-40 ... +180

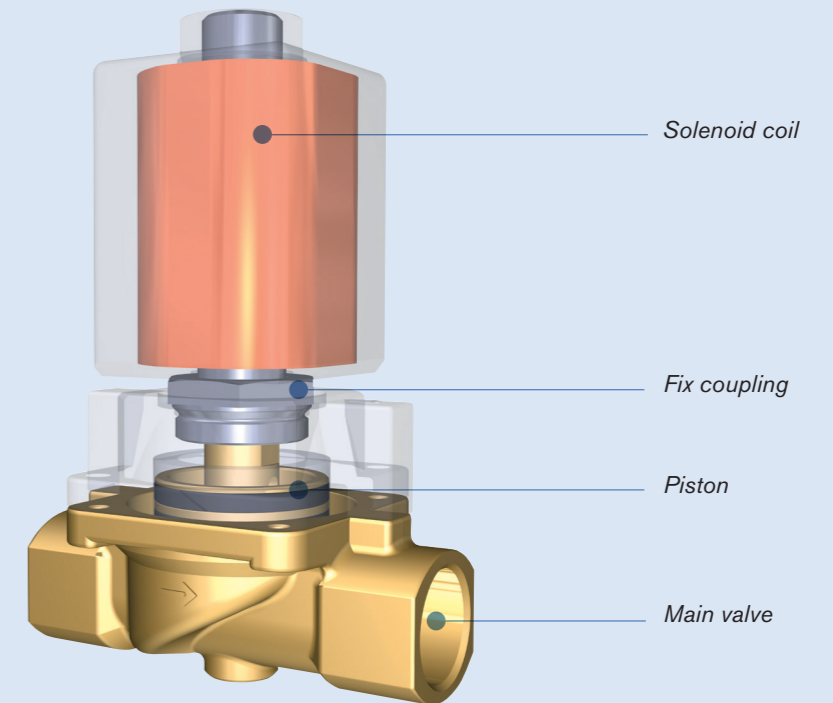

Servo-assisted piston valve, fixed coupled, type 6407

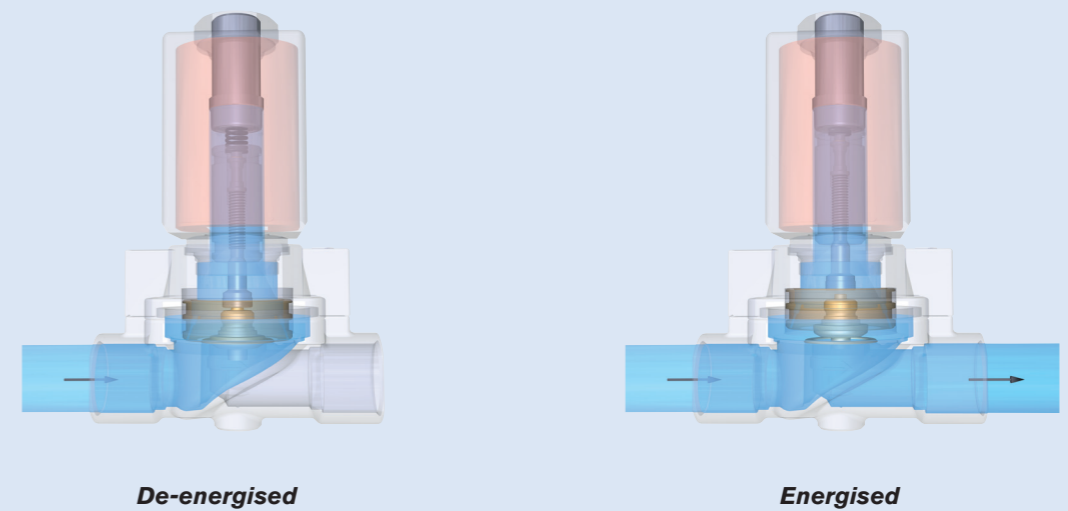

Servo-assisted:

Diaphragm / piston valve with pivoted armature pilot control

Function:

This unique functioning principle uses a media separated, direct-acting 3/2-way valve as the pilot valve, while the seal of the main valve is a larger flexible diaphragm or a piston. As soon as the pilot valve opens, the chamber above the piston opens so that the media pressure raises the diaphragm, therefore allowing the media to flow. If the pilot valve is closed, the channel to the outlet side is also closed and the media pressure can build up again through the inlet-side pilot channel. The closing process is additionally supported by the compression spring. A minimal differential pressure between the inlet and outlet is needed for complete opening and closing.

Application:

The main area of application for this unusual valve is the reliable switching of mildly contaminated and aggressive gases and fluids for diameters DN 10 to 65 mm. This type is designed for universal use. With this valve type there is very little danger of clogging, since the actuator and media chamber are separated by a diaphragm.

Special features:

In some versions of this valve type the opening and closing speed can be adapted to the application and configured for continuous adjustment.

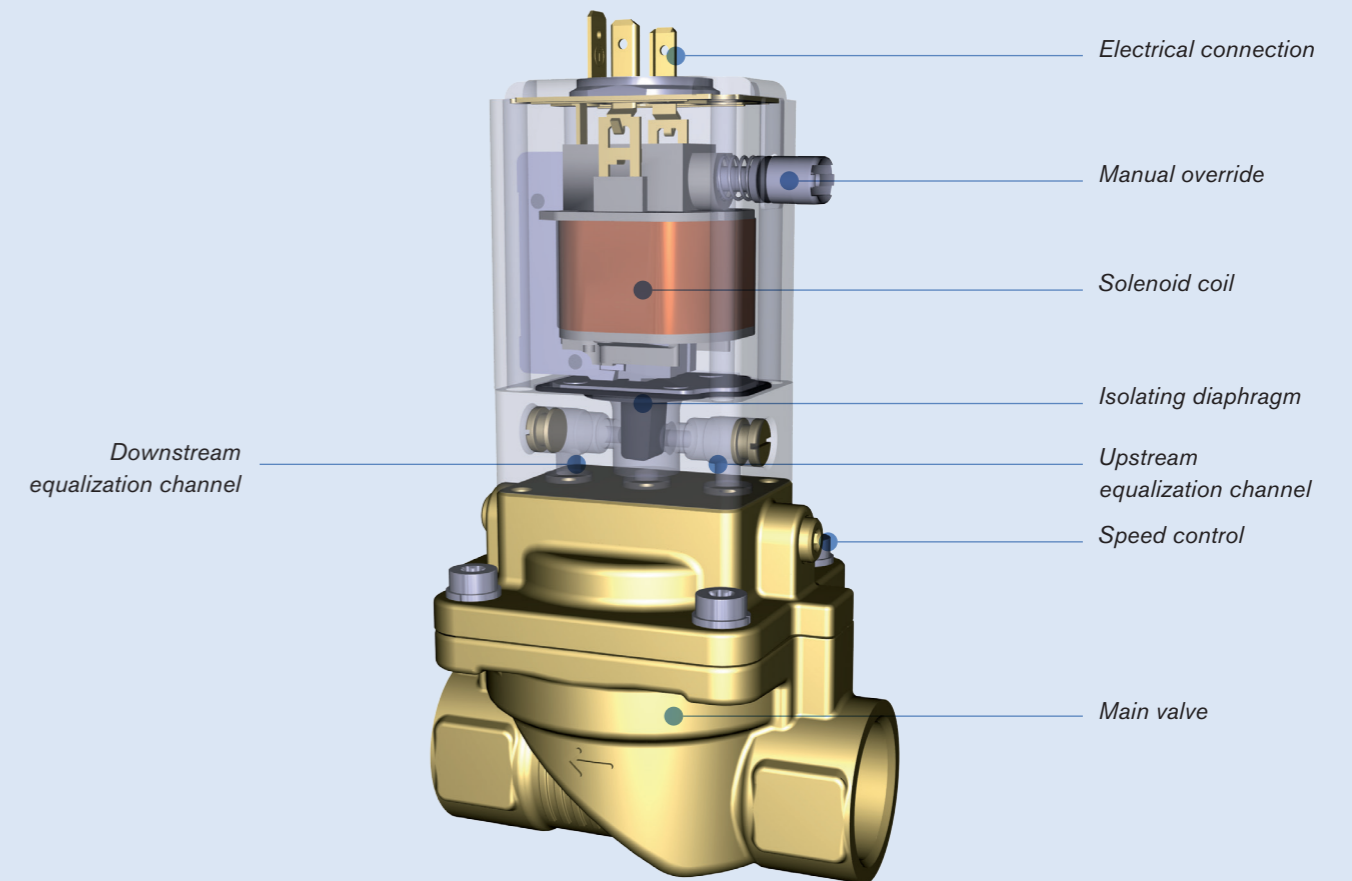

Servo-assisted solenoid valve with 3/2-way pilot type 5282

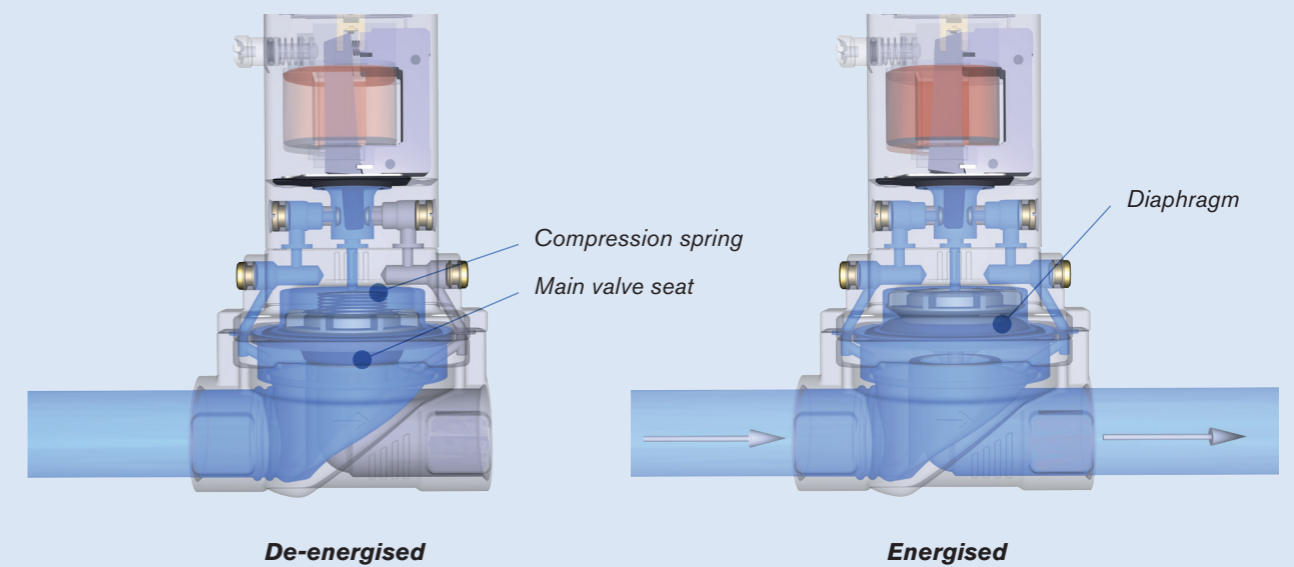

Type	5282	0142	6430
Process connections			
Diameter [DN in mm]	13 ... 65	15 ... 50	8 ... 40
Pressure range [bar]	0.2 ... 10	0.5 ... 6	0.5 ... 16
Temperature [°C]	-30 ... +90	0 ... +70	0 ... +90

Materials of Construction

Bürkert boasts the most modern fully equipped material test facility in which you will find qualified people who have years of experience all directed towards you receiving the correct solenoid valves for your application. These tables are an excerpt from our chemical resistance booklet which is available on the web or from your local Bürkert contact person.

Code	Materials of Construction	General chemical resistance
PA	Polyamide	Resistant to greases, oils, waxes, fuels, weak bases, aliphatic and aromatic hydrocarbons.
EP	Epoxy	Resistant to nearly all chemicals. Not resistant to low-molecular organic acids in high concentrations and highly oxidising substances.
1.4305 1.4401 1.4581	Stainless steel	Resistant to light acids and caustic solutions.
PVC PVC-HT	Polyvinyl chloride, hard	Resistant to most acids and caustic solutions, and saline solutions.
PP PE	Polypropylene Polyethylene	Resistant to many organic solvents, aqueous solutions of acids, bases and salts.
PVDF	Polyvinylidene fluoride	Not resistant to hot solvents such as ketone, ester and highly alkaline solutions.

Code	Materials of Construction	General chemical resistance
PPS	Polyphenyl sulfide	Resistant to aqueous mineral acids, bases, aliphatic and aromatic hydrocarbons, many ketones, alcohols, halogenated hydrocarbons, oils, greases, water and hydrolysis.
PEEK	Polyetheretherketone	Resistant to most chemicals. Not resistant to concentrated sulphuric and nitric acid and certain halogenated hydrocarbons.
PTFE*	Polytetrafluorethylene	Resistant to nearly all chemicals. Not resistant to liquid sodium and fluorides.
EPDM	Ethylene propylene diene rubber	Resistant to ozone and hot water. Not oil and grease resistant.
FKM	Fluorocarbon rubber	Resistant to oil and many chemicals, as well as heat.
NBR	Nitrite rubber	Resistant to oil.
FFKM	Perfluorinated elastomers	Resistant to extreme heat, weather and most chemicals.

* only seal material



Solenoid valves at a glance

Further technical information can be found in our data sheets.
Your Bürkert contact person will be pleased to help you select the right solenoid valve for your application.

Category	Type	Function	Required Δp [in bar]	Process connection	Pressure range [in bar] [in MPa]	Media temperature [in °C]	Diameter [DN in mm]	Body material			Seal material Diaphragm material					Media				Forerunner type	Media separated	Flange version stain-less steel	Version with KD coil available**	Area of application	
								Brass	VA	Plastic	NBR	EPDM	FKM	PTFE*	FFKM*	Neutral fluids	Contaminated fluids	Aggressive fluids	Neutral gases						
Direct-acting plunger valves	7011	2/2	-	M5, G1/8, NPT 1/8, SFB	0 ... 30 0 ... 3	-10 ... +140	1.2 ... 2.4	S	S	S	S	S	S	N	N	x	-	-	x	-	-	-	-	□	
	7012	3/2	-	M5, G1/8 ... 1/4, PIC, NPT 1/8, SFB	0 ... 18 0 ... 1,8	-10 ... +140	1.2 ... 2.0	S	S	S	S	S	S	N	N	x	-	-	x	-	-	-	-	□	
	6013	2/2	-	G 1/8 ... 3/8, NPT 1/8 ... 3/8, SFB	0 ... 25 0 ... 2,5	-10 ... +180	2 ... 6	S	S	N	S	A	S ²	S	A	x	-	-	x	-	-	-	-	□	
	6014	3/2	-	G 1/8 ... 1/4, NPT 1/8 ... 1/4, SFB	0 ... 16 0 ... 1,6	-10 ... +120	1.5 ... 3.0	S	S	S	S	A	S ³	A ⁴	A	x	-	-	x	-	-	-	-	□	
	6027	2/2	-	G 1/4 ... 1/2, NPT 1/4 ... 1/2	0 ... 250 (100) 0 ... 25 (10)	-40 ... +160	1,2 ... 12	S	S	N	N	A	S	S	N	x	-	o	x	0285, 2200, 0243, 0255	-	-	-	-	□
	6026	2/2	-	G 1/4 ... 1/2, NPT 1/4 ... 1/2	0 ... 10 0 ... 1	-200 ... +180	6 ... 10	S	S	N	N	N	N	S	N	x	-	x	x	-	x	-	x		
Direct-acting pivoted armature valves	0330	2/2 3/2	-	G 1/4, NPT 1/8	0 ... 16 0 ... 1,6	-30 ... +90	2 ... 4	S	S	N	S	A	S	N	A	x	x	x	x	0124, 0332, 0780, 0788	x	-	x		
	0331	2/2 3/2	-	SFB	0 ... 16 0 ... 1,6	-30 ... +90	2 ... 3	S	S	N	N	A	S	N	N	x	x	x	x	0125, 0333, 0780, 0788	x	-	x		
	0121	2/2 3/2	-	G 1/4, G 3/8	0 ... 4 0 ... 0,4	-10 ... +90	2 ... 8	N	S	S	N	A	S	N	S	x	x	x	x	0789	x	-	x		
Direct-acting toggle valves	0131	2/2 3/2	-	G 3/8 ... 1/2	0 ... 3 0 ... 0,3	-30 ... +50	10 ... 25	S	N	S	N	S	S	N	N	x	x	x		0323, 0223	x	-	x		
Servo-assisted piston valves	6240	2/2	-	G 1/4 ... 1/2	0 ... 250 (25/40) 0 ... 25 (2,5/4)	-40 ... +160	6, 12, 13	S	S	N	N	A	S	S	N	x	-	o	x	2400	-	-	x	○	
	5404	2/2	1.0	G 1/2 ... 1, NPT 1/4 ... 2, DIN flange	1 ... 50 0,1 ... 5	-10 ... +160	12 ... 25	S	N	N	S	N	A	S	N	x	-	-	x	0404, 0406	-	x	-	○	
	6407	2/2	-	G 1/2 ... 1, DIN flange	0 ... 10 0 ... 1	-20 ... +150	13 ... 25	S	N	N	N	N	N	S	N	x	-	-	x	0407	-	x	x	○	
	6430	3/2	0.5	G 1/4 ... 1 1/2	0,5 ... 16 0,05 ... 1,6	0 ... +90	8 ... 40	S	N	N	S	N	N	N	N	x	-	-	x	0342, 0786, 0340, 0343, 0344	x (Pilot)	-	-		
Servo-assisted diaphragm valves	6213EV	2/2	- (HP00)	G 1/4 ... 2, NPT 3/8 ... 1	0 ... 10 0 ... 1	-30 ... +120	10 ... 40	S	S	N	S	S	S	N	N	x	-	-	x	-	-	-	x	△	
	6281EV	2/2	0.5	G 3/8 ... 2, NPT 1/2 ... 1	0,2 ... 16 0,02 ... 1,6	-30 ... +120	10 ... 50	S	S	N	S	S	S	N	N	x	-	-	x	0280, 5281	-	-	-	△	
	0290	2/2	-	G 1/2 ... 2, NPT 1/2 ... 2 1/2, DIN flange	0 ... 16 0 ... 1,6	-30 ... +120	12 ... 50	S	S	N	S	S	S	N	N	x	-	-	x	-	-	x	x	△	
	5282	2/2	0.2	G 1/2 ... 2 1/2, DIN flange	0,2 ... 16 0,02 ... 1,6	-30 ... +90	13 ... 50	S	S	S ¹	S	S	S	N	N	x	x	x	x	-	x (Pilot)	x	-	△	

PIC = Push-in connection | SFB= Specific flange Bürkert
 □ Universal for gases + fluids
 ○ Gas and/or steam applications
 △ suitable for water applications

S = Standard | A = On request | N = Not available | 1 = plastic version: Type 0142 | 2 = only as seat seal | 3 = only as seat seal and DN 2.0 | 4 = only up to 2.0

* only as seal material | ** To reduce power consumption in operation coils with "Kick and Drop" (KD) electronics (double coil technology) are available.
 x = suitable/yes | o = partially suitable | - = not suitable/no

Selection Chart Micro Fluidics

Category	Type	Function	Width [in mm]	Process connection	Pressure range [in bar] [in MPa]	Media temperature [in °C]	Diameter [DN in mm]	Body material			Seal material Diaphragm material					Media			
								Brass	VA	Plastic	NBR	EPDM	FKM	PTFE*	FFKM*	Neutral fluids	Contaminated fluids	Aggressive fluids	Neutral gases
Direct-acting rocker valves	0127	3/2	16	G 1/8, NPT 1/8, UNF 1/4" - 28 SFB	0 ... 6 0 ... 0.6	-10 ... +55	0.8 ... 1.6	N	N	S	N	S	S	S	S	S	S	S	S
	6624	3/2	10	UNF 1/4" - 28, hose connection, SFB	0 ... 5 0 ... 0.5	-10 ... +55	0.8 ... 1.6	N	N	S	N	S	S	N	S	S	S	S	S
	6106	3/2	16	SFB	0 ... 10 0 ... 1	-10 ... +55	0.9 and 1.2	N	N	S	S	N	S	N	N	N	N	N	S
	6626	3/2	16	G1/8, UNF 5/16" - 24, hose connection, SFB	0 ... 5 0 ... 0.5	-10 ... +50	2.0 and 3.0	N	N	S	N	S	S	N	S	S	S	S	S
	6628	3/2	22	G1/8, NPT 1/8, PIC, hose connection, SFB	0 ... 5 0 ... 0.5	-10 ... +55	2.0 and 3.0	N	N	S	N	S	S	N	S	S	S	S	S
Direct-acting flipper valves	6650	3/2	4,5	SFB	0 ... 7 0 ... 0.7	+15 ... +55	0.4 and 0.8	N	N	S	N	N	N	N	S	S	S	S	S
	6144	3/2	10	SFB	0 ... 7 0 ... 0.7	0 ... +55	0.6	N	N	S	N	S	S	N	N	S	N	N	S

PIC = Push-in connection | SFB= Specific flange Bürkert

S = Standard | A = On request | N = Not available

* only as seal material | x = suitable | o = partially suitable | - = not suitable

Added Value Systems

Bürkert has a unique perspective in the process control and instrumentation industry as we are the only single brand which combines a complete range of valves, instruments, pneumatic actuation, networking and controllers from a single source.

With our dedicated world-class engineers and our superlative manufacturing facilities we can deliver systems which meet your exact requirements.

Your reliable Bürkert sales consultant and our system engineers work in concert to ask the right questions and provide the right hardware. Transparent operations, up to date situation, review procedure, engineering change notices, portals through SAP and secure intranet are normal in our projects.

For a world class system experience, insist on Bürkert people to be part of your next project.



01

Connect

As a globally flexible, lean, focused and innovative company we are the partner of choice for fluid control systems in more than 35 countries. Whether you are in Stuttgart, Singapore, Chicago or Sydney, everywhere in the world, we are close to you and therefore know at first-hand about your specific tasks and problems.

Following our principle of "one face to the customer", you have a competent, reliable consultant by your side at all times, who listens to your needs and presents a solution in your daily application language ... crossing conventional boundaries and creating synergies between industries in pursuit of your ideal solution.

Systemhaus crews in Charlotte (USA), Suzhou (China), Dresden, Ingelfingen and Dortmund are continuously in innovation mode. They creatively engineer cost effective solutions to meet difficult process challenges for our customers.



02

Conceive & Innovate

Your project team starts working for you: from your reliable sales consultant, qualified industry specialists to dedicated system engineers – Bürkert puts the necessary experts together.

For the entire duration of the project they work together, combining their experience and clarifying all the requirements in close cooperation with you to come up with a feasible draft of your solution within the shortest timeframe.

CAD-created animations or simulations, combined with extended manufacturing, materials, tool design, construction and assembly knowledge enable us to provide a rough but firm production concept for your system at an early stage.



03

Plan & Specify

In Phase 3 the project is planned in detail. A specification sheet and refined solution concept are developed. This defines exactly what you expect from the system and what it must provide to ensure that all components meet your requirements.

At the end of this phase you are presented with a detailed product definition, a production specification and precise commercial conditions and agreements.

Structured project management based on open communication, effective coordination and thorough documentation ensures fast and reliable results.



04

Do & Check

Good communication, coordination and documentation at all project phases make sure that we are on the right track, developing the right solution, to allow us to quickly move on to prototyping.

Thanks to the latest technology, we are able to build a prototype made of metal or plastic or a functional model to test flow for example within 24 hours.

We provide you with samples; we perform tests and, of course, obtain all the necessary local and global approvals to make sure the system can go to production.

From here we work in concert with one of our production facilities in Ingelfingen, Gerabronn, Criesbach, Öhringen or Triembach according to their individual core manufacturing competencies.

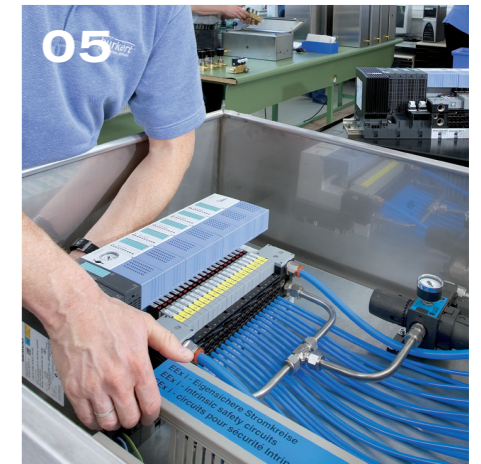

05

Complete

Our work does not end with the perfect delivery of components and systems. We offer a comprehensive program to our global clients interlinking services ranging from maintenance and service contracts, operator training and integrated logistics.

Our customer service is available around the clock, offering support through internet, telephone or our qualified, experienced people at your site.

We aim to provide only the utmost in customer experience. Something you will tell your friends about.

Systems

The combination of customised fluidics and the right valve types always offers a compact and cost-optimised alternative. Here you will find an overview of customised system solutions.



Foam distributor

Gas control system

Vacuum control unit

Water mixing unit

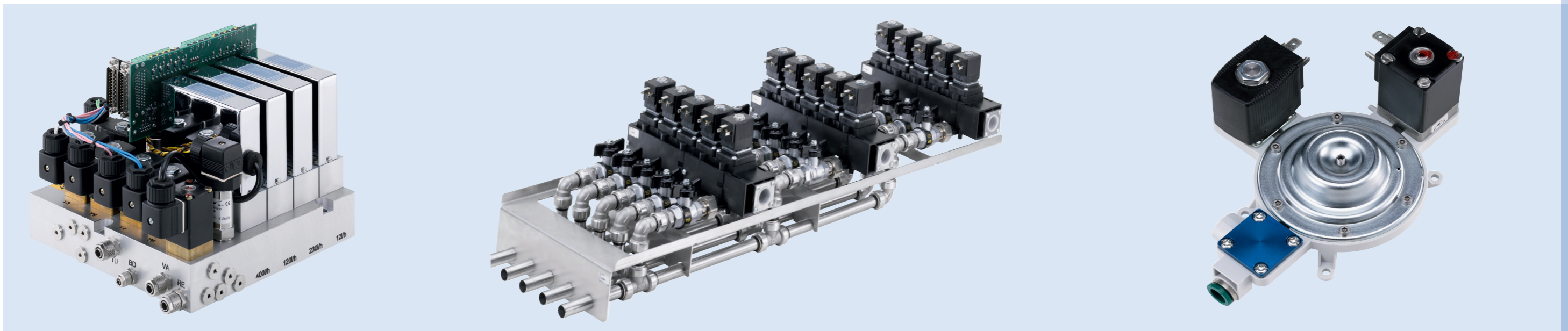

Gas mixer

Car wash distributor

Medical insufflation control

Our Service Promise

We have made the investment to be close to you both geographically and in your market. We offer a comprehensive program of interlinking services which include:

Everything from one Partner

We have tens of thousand of process engineering products in our program. We know exactly how to program them, install them and combine them according to your wishes.

Customer Service around the Clock

We offer support through internet, telephone or people on the ground at your site. We are available around the clock.

Start-up

We are always available for installation and commissioning as well as for local staff and operator training.

Global Operations

We are close by in 35 countries in a network which guarantees the full achievement of our enterprise to each customer on each continent.

Please be assured that we are always available to help personally, really listening to your requirements with your success in mind. We are only content when your specific problem was solved.

Bürkert – Close to You

For up-to-date addresses please visit us at www.burkert.com.

Austria
Belgium
Czech Republic
Denmark
Finland
France
Germany
Italy
Netherlands

Norway
Poland
Portugal
Spain
Sweden
Switzerland
Turkey
United Kingdom

Russia

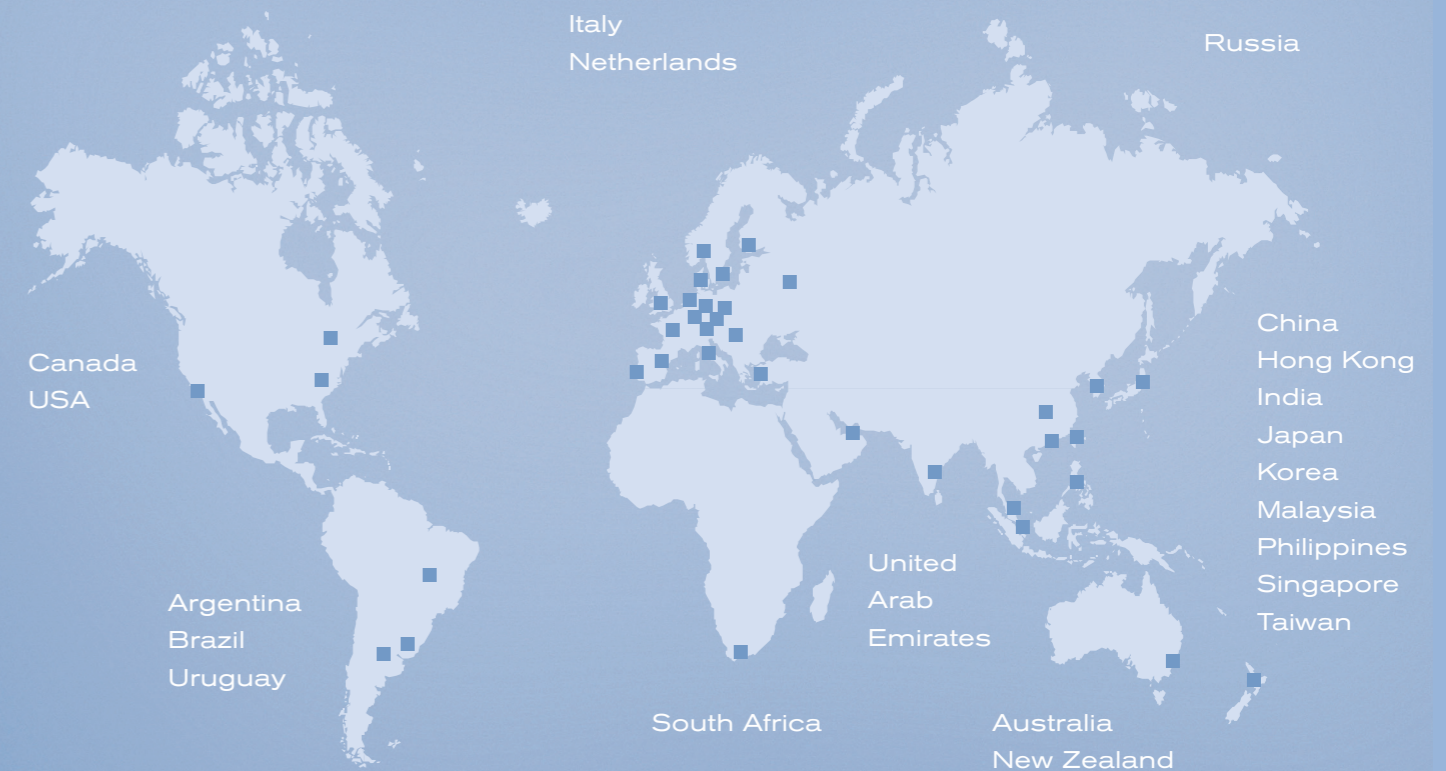



bürkert
FLUID CONTROL SYSTEMS

Bürkert Fluid Control Systems

Christian-Bürkert-Straße 13-17
74653 Ingelfingen
Germany

Tel. +49 7940 100
Fax +49 7940 1091204

info@burkert.com
www.burkert.com